

June 12, 1934.

A. R. THOMPSON
FILLING VALVE FOR SIRUPERS

1,962,161

Filed Jan. 26, 1932

2 Sheets-Sheet 1

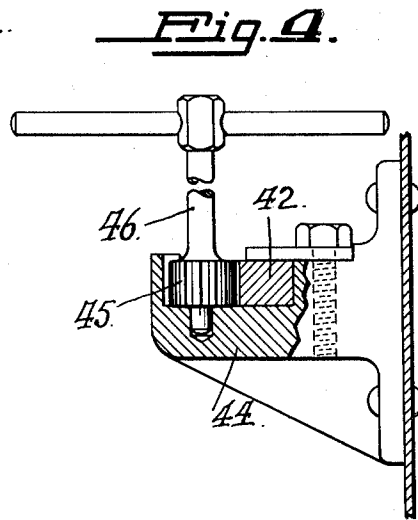
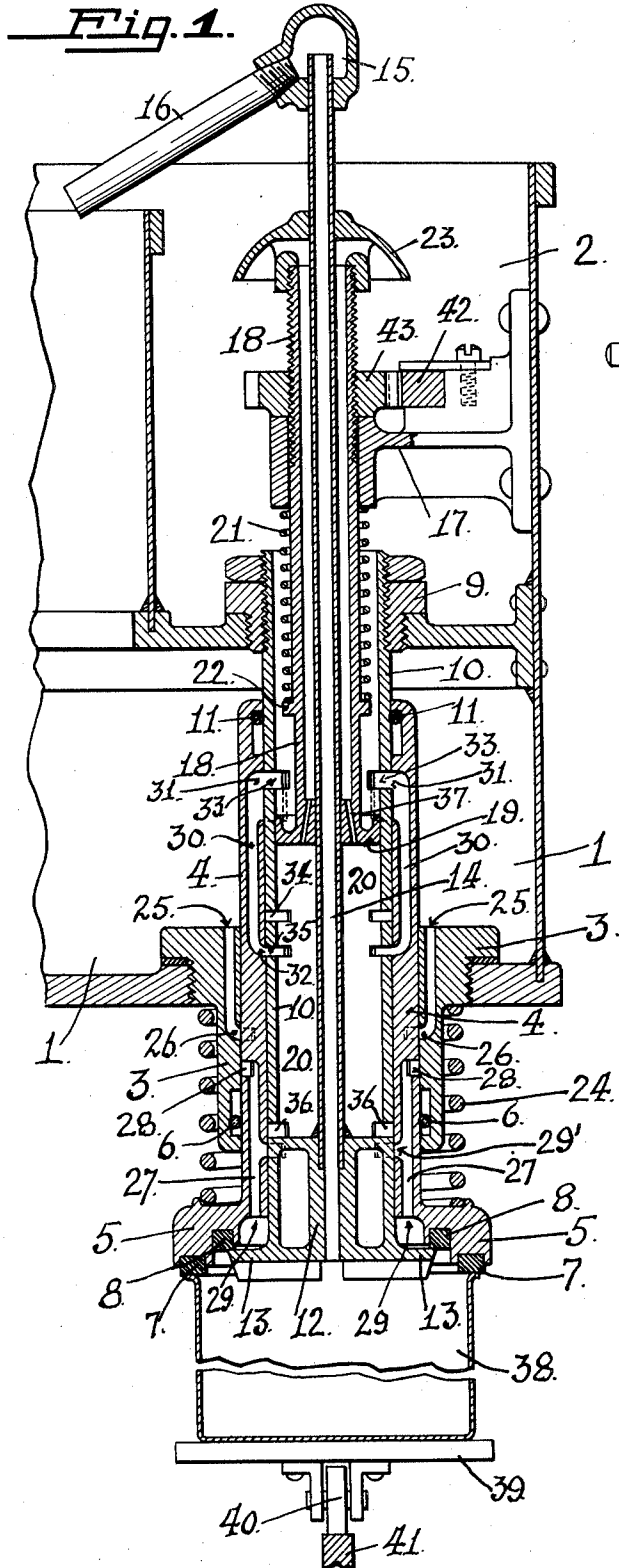

INVENTOR,
Albert R. Thompson
BY *Booth & Booth*
ATTORNEYS.

June 12, 1934.

A. R. THOMPSON

1,962,161

FILLING VALVE FOR SIRUPERS

Filed Jan. 26, 1932

2 Sheets-Sheet 2

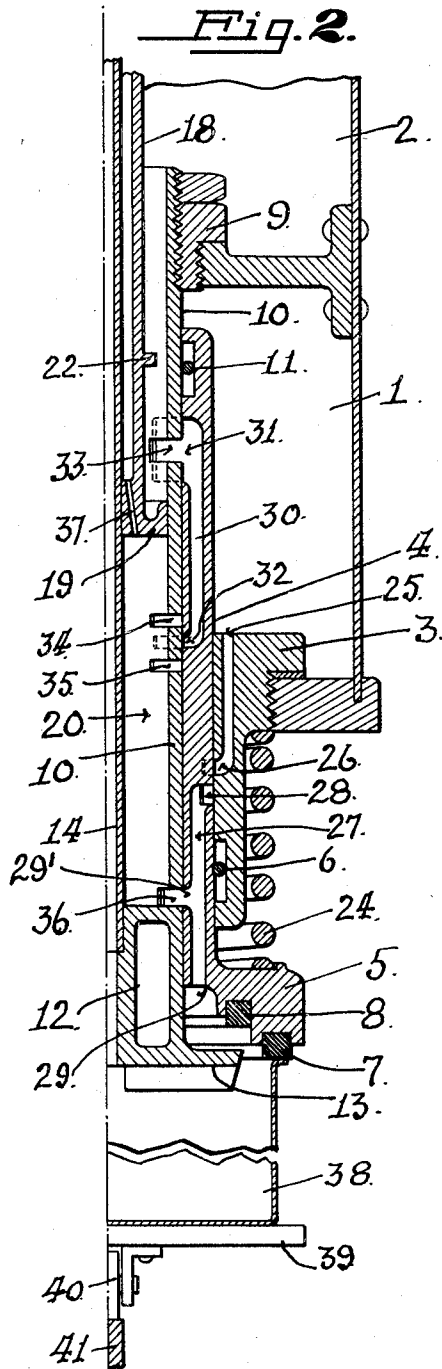
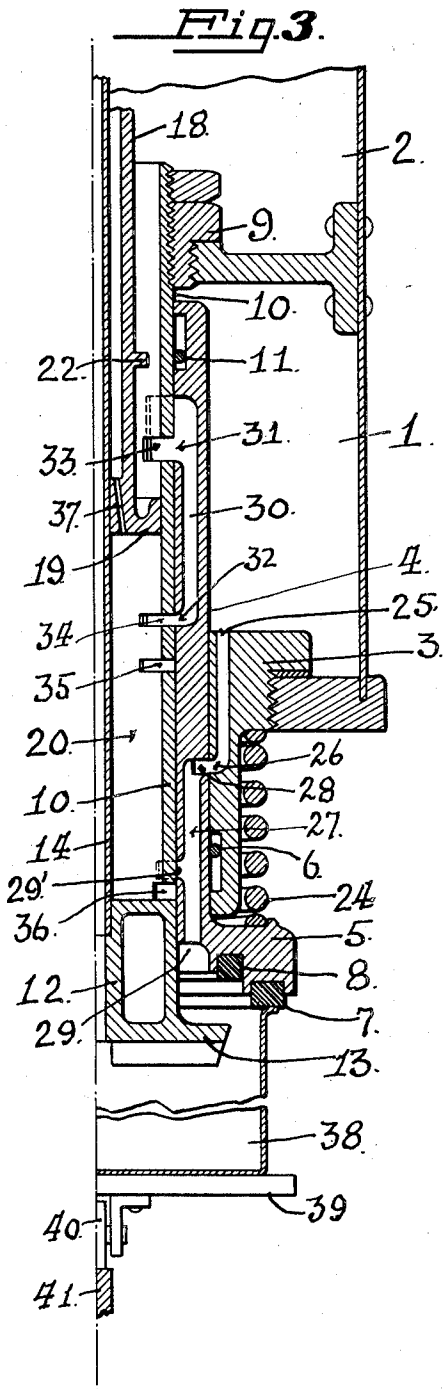

INVENTOR,
Albert R. Thompson
BY *Booth + Booth*
ATTORNEYS.

UNITED STATES PATENT OFFICE

1,962,161

FILLING VALVE FOR SIRUPERS

Albert R. Thompson, San Jose, Calif., assignor
to Food Machinery Corporation, San Jose,
Calif., a corporation of Delaware

Application January 26, 1932, Serial No. 589,032

9 Claims. (Cl. 226—100)

My invention relates generally to valves for filling containers; and particularly to filling valves for sirupers as used in the canning art.

The type of valve with which my improvement is concerned is that in which the elevation of the can lifts the normally closed valve to open its passages and ports to a sirup flow, through the communication thus established, said type being further characterized by the introduction into the can, during said flow, of a displacement body, the subsequent withdrawal of which provides for a safe lowering of the sirup level in the can.

The essential object of my present invention is to provide a filling valve of this general type capable as a unitary structure of supplying successively two fluids; in practice, two liquids, differing as predetermined.

In particular, the object is to provide a simple and effective single valve structure for supplying first, a concentrated sirup, followed by a diluent liquid, in practise water or a weaker sirup.

The ultimate object is to avoid waste by overflow excess or spilling either in filling or during subsequent processing.

The nature of my improved valve and the manner in which it operates will hereinafter fully appear.

In the accompanying drawings, I have shown my valve in its preferred form, though it is to be understood that changes may be made therein, both in structure and arrangement, without departing from the spirit of the invention as defined in the claims hereunto appended.

In the drawings, Fig. 1 is a vertical sectional view of the valve showing it in its normal or inoperative condition, just as the can has been elevated to a closure contact or seating of its open top.

Fig. 2 is a vertical sectional view, broken, of one half the valve showing its condition under the further elevation of the can by which the valve passages and ports are opened to a flow of the first liquid into the can.

Fig. 3 is a similar sectional view but showing the condition of the valve under a still further elevation of the can, adapted for causing a flow into the can of the second liquid.

Fig. 4 is a detail showing a means for operating the ring gear by which the measuring chambers for the first liquid of a plurality of valves may be varied as to volume capacity.

1 is a tank forming the source of supply of one liquid, and 2 is a tank for supplying another liquid. In the bottom of tank 1 is fitted a down-

wardly protruding sleeve 3 forming an outer guide within which the tubular stem 4 of a valve head 5 is adapted for vertical movement, a rolling ring gasket 6 being interposed near the lower end for packing. The lower face of the valve head 5 is provided with concentric sealing gaskets at slightly different elevations, the outer one being designated by 7 and the inner one by 8.

Carried by the bottom of tank 2 is a jam-nut fitting 9 in which is screwed the upper end of a tubular stem 10 which passes down through the tubular valve-stem 4 for which it forms an inner guide, a rolling ring gasket 11 being interposed near the upper portion of said stem 4.

The stem 10 has at its foot a closure member 12 with a bottom flange 13 of a diameter sufficient to span the inner sealing gasket 8 in order to form a seat therefor, said seat flange being, by reason of the screw fitting of its stem 10 in the fitting 9, adapted for vertical adjustment to regulate the depth of its intrusion into the can as a displacement body, as will be presently described. 14 is an air vent tube opening below through the valve seat flange 13 and thence rising through the stem 10 and tank 2 to a shield chamber 15 and directing vent 16.

Fitted for vertical adjustment in a bracket 17 secured to the wall of the tank 2 is a tubular piston-stem 18 which passes down into the stem 10, and around the vent tube 14 and is spaced from both stem and tube.

The stem 18 carries upon its lower end a piston 19 fitting within the stem 10 and defining the upper limit of a measuring chamber 20 formed in said stem 10, the foot closure member 12 forming the lower limit of said chamber 20.

A spring 21 around the piston stem 18 bearing below on a collar 22 thereon and above against the bracket 17, serves to steady the piston 19 in its normal position as set. The upper end of the stem 18 carries an air vent hood 23. A spring 24 yieldingly controls the movement of the valve head 5 and its stem 4.

The several fluid passages, both for air and liquid, and their controlling ports will now be described.

In the upper end of the guide sleeve 3 and opening directly out of the tank 1 is a passage 25 which at its base opens through the inner wall of said sleeve forming a port 26.

In the lower portion of the wall of the valve stem 4 is made a passage 27 which at its upper end opens outwardly through the stem wall forming a port 28. At its lower end said passage 27

opens through the valve head 5 at 29; and intermediate its ends it has an inwardly opening port 29'.

In the upper portion of the wall of the valve stem 4 is made a passage 30 which at its upper end opens inwardly through said wall as a port 31. At its lower end said passage 30 opens inwardly as a port 32. Through the wall of the stem 10, above the level of the piston 19, is made a port 33; and through said wall below the piston is a port 34, and another port 35 a little lower. Through said stem wall at its lower end just above the foot member 12 is made the port 36. The liquid from tank 2 finds its outlet through the top of the stem 10 and down in the space between said stem and the piston stem 18 to the piston 19 which defines the lower limit of said space.

Through the piston 19 is made the air vent passage 37 which opens from the top of the measuring chamber 20 and leads into the piston stem 18.

Since, in this art, in order to fully understand the structure and operation of the filling valve, it has been unnecessary to involve the disclosure with a description and showing of the relatively elaborate and complete sirupers, bottling machines and other filling apparatus, it is considered that the showing herein in respect to the following matters particularly will be sufficient to indicate the well known type of such apparatus or machines in which a plurality of containers and valves move together in a circular path, during and because of which the filling is accomplished. Accordingly I have herein shown a can 38 on a table 39 which has a vertical movement due to a roller 40 traveling on a cam track 41, so that said can is timely elevated to its filling valve and lowered therefrom; and I have also shown, as a means for simultaneously adjusting the pistons 19 of all the valves, to vary the capacity of the measuring chamber 20, a gear 42 meshing with a pinion 43 on the piston stem 18, it being understood that said gear 42 is a ring gear engaging the pinions 43 of all the valves.

In Fig. 4 I show said ring gear as fitted revolvably in a clamp bracket 44 and adapted to be rotated by a pinion 45 operated by a handled shaft 46.

Each filling valve may, however, be individually varied with respect to the capacity of its measuring chamber 20, by manually lifting its piston stem 18 to free the pinion 43 from the ring gear 42, and turning said pinion up or down to the desired point. Any suitable means, not shown, are provided for preventing the piston stem from rotating, without impeding its vertical movement.

From the following description of the operation, a clear understanding will be had.

Referring first to Fig. 1. The can 38 has just been lifted to the outer gasket 7 of the valve head 5 thereby closing its open top. The inner gasket 8 still rests upon the foot flange 13, preventing any liquid from flowing into the can. The liquid from tank 2 has entered the open top of the stem 10 and being stopped by the piston 19 has passed outwardly through port 33 in stem 10 and port 31 in valve stem 4 into the passage 30 in said valve stem. Thence it has passed through lower port 32 in the valve stem, and the port 35 in the stem 10 into and has filled the measuring chamber 20, the air in said chamber having escaped through the vent passage 37 in the piston 19. In this chamber the liquid is confined, the lower ports 36 at the base of the chamber being closed to the intermediate port 29' of

the valve stem 4. No liquid from the tank 1 can pass out because the passage 25 in sleeve 3 and its port 26 are closed by the valve stem 4.

Refer now to Fig. 2: The can has been further elevated slightly. This movement by contact with the outer gasket 7 raises the valve head 5 and lifts the inner gasket 8 from its closure on top of the foot flange 13 so that the way is open into the can. Said movement also has opened, by the elevation of the valve stem 4, the bottom port 36 of the measuring chamber 20 so that the measured charge of liquid flows out through port 29' into the passage 27 and down through said passage and past the separated gasket 8 and foot flange 13 into the can, while the air returns into the emptying chamber through the piston passage 37, and the air from the can is driven out through the vent tube 14. But still no liquid from the tank 1 has passed out, because the elevation of the valve stem 4 has not been enough to register the ports 28 and 26.

Refer now to Fig. 3. The can has been still further elevated. Now the ports 28 and 26 in the passages 27 and 25 respectively are aligned and the liquid from tank 1 flows through said passages and down into the can past the still separated gasket 8 and foot flange 13. Meanwhile the liquid from the tank 2 has been refilling the measuring chamber 20, the lower port 32 of the valve stem passage 30 having been brought into register with the upper port 34 in stem 10; and the outlet from said chamber being closed by reason of the ports 36 and 29 being out of register.

When the can is lowered for final separation from the filling device, the latter resumes its initial position for a repetition of the operation.

Two fluids, both gaseous or both liquid; or one a liquid and the other a gas may thus be supplied by a single filling valve in what is practically a single operation at a single station, instead of using separate valves at stations more or less remote.

The nature of the two fluids may vary in accordance with the art in which they are required; but in the siruping art a known special use involves the employment of a first sirup, judiciously concentrated, in accordance with the nature of the fruit, and carefully supplied in predetermined volume, followed by a diluent liquid, usually water, to reduce the concentrate to the proper grade, thus obviating the necessity of either keeping on hand a plurality of grades or of changing the grade for each run of fruit.

For such a use, my two sirup valve as herein described is particularly adapted, in that the first or concentrated liquid is supplied from tank 2 in measured volume, while the diluent liquid is supplied from tank 1 under conditions which avoid waste, by making use of the well known intruding displacement body, thereby providing for an apparent can fullness, but ultimately, by removal from the can, causing a reduction in the liquid level in a predetermined degree to insure safety from spilling during subsequent processes. In this connection, and for this purpose, it will be seen, by reference to the position shown in Fig. 3 that the elevation of the can to the height necessary to open the valve to the second or diluent liquid from tank 1 has caused the penetration of the foot flange 13 into the can to such a depth that it functions as a displacement body in the same way and with the same effect as heretofore in cam filling valves supplying a single liquid.

Therefore, whatever may be the nature of the diluent liquid it is supplied without excess or waste either in filling or subsequently, in after-processes; and in case the diluent liquid be itself a thinner sirup, such saving is important; and is of value even when water is used as a diluent, since the water mixing with the sirup cannot be spilled without waste.

I claim:—

1. A filling valve for supplying containers with two fluids, comprising two distinct sources of fluid supply, each having an outlet for communication with the container; a single valve member adapted for establishing and controlling said communication to separately admit and close off the fluids to and from the container; means incorporated in said communication and under the control of said valve for defining the volume of one of the admitted fluids; and means for defining the ultimate level in the container of the fluid aggregate admitted.

2. A filling valve for supplying containers with two fluids, comprising two distinct sources of fluid supply, each having an outlet for communication with a container; a single valve member adapted for establishing and controlling said communication to separately admit and close off the fluids to and from the container; a charge-measuring chamber incorporated in said communication, which chamber is under the control of said valve, for defining the volume of one of the admitted fluids; and a container-penetrating displacement body for defining the ultimate level in the container of the fluid aggregate admitted.

3. A filling valve for supplying containers with two fluids, comprising two distinct sources of fluid supply, each having an outlet for communication with the container; a single valve member adapted for establishing and controlling said communication to separately admit and close off the fluids to and from the container; means incorporated in said communication and under the control of said valve for defining the volume of one of the admitted fluids comprising a charge-measuring chamber; a container-penetrating displacement body for defining the ultimate level in the container of the fluid aggregate admitted; and means for varying the functional capacity of said chamber and body.

4. A filling valve for containers comprising two liquid supply tanks in vertical relation; an outlet sleeve fitted in and extending downwardly from the bottom of the lower tank; an outlet tubular stem fitted in the bottom of the upper tank and extending down through and concentrically spaced from the outlet sleeve of the lower tank; and a vertically yielding valve-head adapted for closure connection with the container, said head having a tubular stem, fitted concentrically between and guided by said outlet sleeve and outlet stem, said valve stem having passages and ports for separately controlling the flow of liquid from the tanks.

5. A filling valve for containers comprising two liquid supply tanks in vertical relation; an outlet sleeve fitted in and extending downwardly from the bottom of the lower tank; an outlet tubular stem fitted in the bottom of the upper tank and extending down through and concentrically spaced from the outlet sleeve of the lower tank, said stem having formed within it a charge-measuring chamber; and a vertically yielding valve-head adapted for closure connection with the container, said head having a tubular stem fitted concentrically between and

guided by said outlet sleeve and outlet stem, said valve stem having passages and ports for separately controlling the flow of liquid from the tanks.

6. A filling valve for containers comprising two liquid supply tanks in vertical relation; an outlet sleeve fitted in and extending downwardly from the bottom of the lower tank; an outlet tubular stem fitted in the bottom of the upper tank and extending down through and concentrically spaced from the outlet sleeve of the lower tank, said stem having formed within it a charge-measuring chamber; means for varying the volume capacity of said chamber; and a vertically yielding valve-head adapted for closure connection with the container, said head having a tubular stem fitted concentrically between and guided by said outlet sleeve and outlet stem, said valve stem having passages and ports for separately controlling the flow of liquid from the tanks.

7. A filling valve for containers comprising two liquid supply tanks in vertical relation; an outlet sleeve fitted in and extending downwardly from the bottom of the lower tank; an outlet tubular stem fitted in the bottom of the upper tank and extending down through and concentrically spaced from the outlet sleeve of the lower tank, said stem having formed within it a charge-measuring chamber; means for varying the volume capacity of said chamber comprising an adjustable piston therein; and a vertically yielding valve-head adapted for closure connection with the container, said head having a tubular stem fitted concentrically between and guided by said outlet sleeve and outlet stem, said valve stem having passages and ports for separately controlling the flow of liquid from the tanks.

8. A filling valve for containers comprising two liquid supply tanks in vertical relation; an outlet sleeve fitted in and extending downwardly from the bottom of the lower tank; an outlet tubular stem fitted in the bottom of the upper tank and extending down through and concentrically spaced from the outlet sleeve of the lower tank, said stem having at its lower end a container-penetrating displacement body; and a vertically yielding valve-head adapted for closure seating upon the container top and upon said displacement body, said valve head having a tubular stem fitted concentrically between and guided by said outlet sleeve and outlet stem, said valve stem having passages and ports for separately controlling the flow of liquid from the tanks.

9. A filling valve for containers comprising two liquid supply tanks in vertical relation; an outlet sleeve fitted in and extending downwardly from the bottom of the lower tank; an outlet tubular stem fitted in the bottom of the upper tank and extending down through and concentrically spaced from the outlet sleeve of the lower tank, said stem having formed within it a charge-measuring chamber with means for varying its volume capacity and said stem having at its lower end a container-penetrating displacement body; and a vertically yielding valve-head adapted for closure seating upon the container top and upon said displacement body, said valve head having a tubular stem fitted concentrically between and guided by said outlet sleeve and outlet stem, said valve stem having passages and ports for separately controlling the flow of liquid from the tanks.