

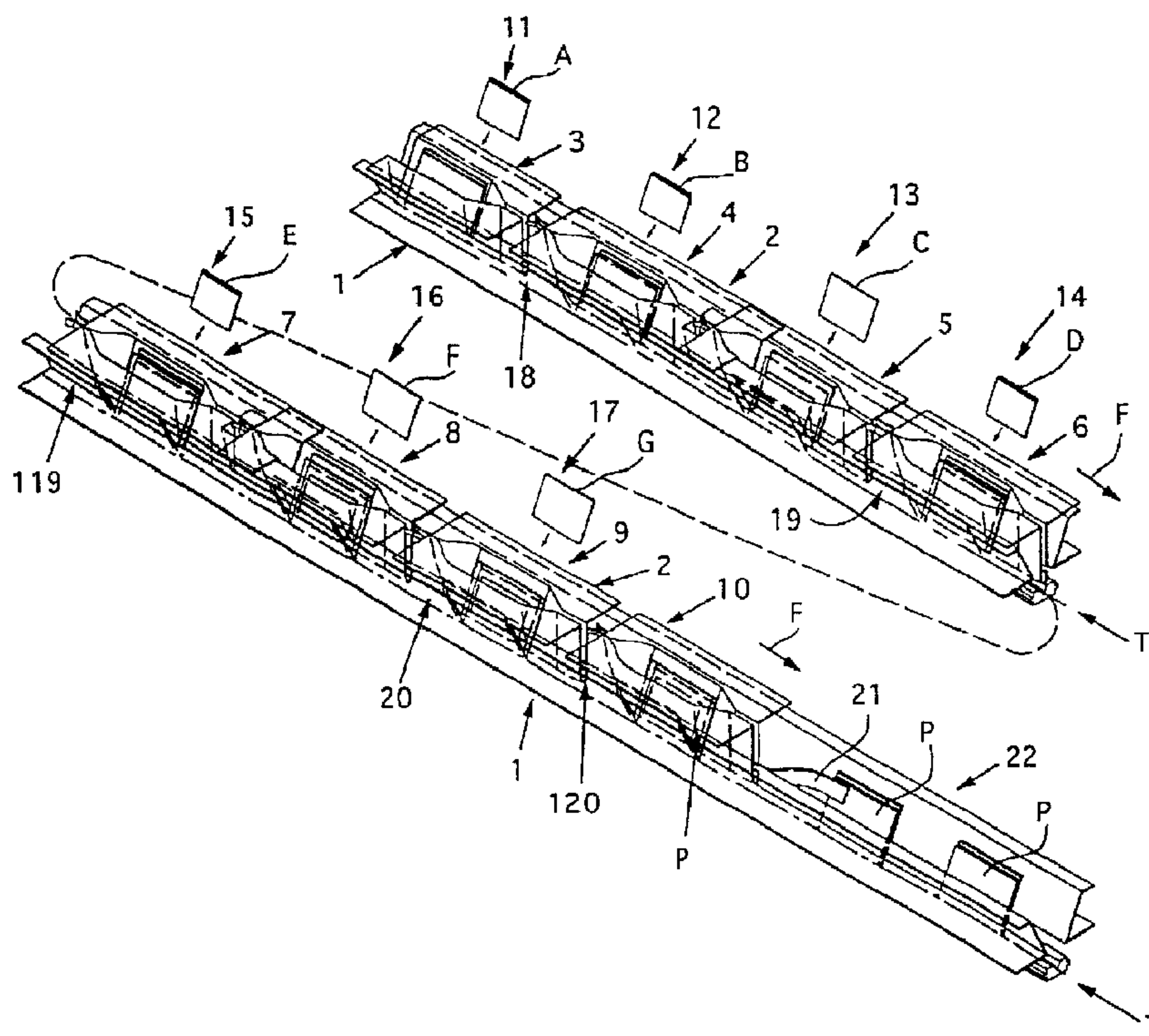

(86) Date de dépôt PCT/PCT Filing Date: 1998/01/20
 (87) Date publication PCT/PCT Publication Date: 1998/08/20
 (45) Date de délivrance/Issue Date: 2006/07/11
 (85) Entrée phase nationale/National Entry: 1999/06/30
 (86) N° demande PCT/PCT Application No.: CH 1998/000015
 (87) N° publication PCT/PCT Publication No.: 1998/035901
 (30) Priorité/Priority: 1997/02/14 (CH325/97)

(51) Cl.Int./Int.Cl. *B65H 39/055* (2006.01),
B65H 39/075 (2006.01), *B65H 5/30* (2006.01)
 (72) Inventeur/Inventor:
JAEGER, ERICH, CH
 (73) Propriétaire/Owner:
FERAG AG, CH
 (74) Agent: GOWLING LAFLEUR HENDERSON LLP

(54) Titre : DISPOSITIF POUR PRODUIRE DES IMPRIMES EN PLUSIEURS PARTIES
 (54) Title: DEVICE FOR PRODUCING PRINTED MATERIALS IN SEVERAL PARTS



(57) **Abrégé/Abstract:**

A processing channel aligned with respect to a continuous, upwardly open transport channel (1) is arranged above the transport channel (1). The transport channel (1) determines together with the processing channel (2) a processing path, along which are arranged successive supply stations (11-17) for supplying the printed material parts (A to G). The processing channel (2) has individual, successive processing zones (3-10) between which are provided passages (18, 19, 119, 20, 120) through which the printed material parts (A to G) located in the processing channel (2) can reach the underlying transport channel (1). The printed material parts (A to G) are opened or deflected to one or another side during their transport between one processing zone to the next processing zone (3-10). Depending on the design of the processing zones (3-10) and on the arrangement of the passages (18, 19, 119, 20, 120), the inner parts (B to G) are arranged in a particular manner in the end printed material (P), either next to or inside one another.



PCT WELTORGANISATION FÜR GEISTIGES EIGENTUM
Internationales Büro
INTERNATIONALE ANMELDUNG VERÖFFENTLICHT NACH DEM VERTRAG ÜBER DIE
INTERNATIONALE ZUSAMMENARBEIT AUF DEM GEBIET DES PATENTWESENS (PCT)

| | | |
|---|-----------|--|
| (51) Internationale Patentklassifikation ⁶ : B65H 39/055, 39/075, 5/30 | A1 | (11) Internationale Veröffentlichungsnummer: WO 98/35901 |
| | | (43) Internationales Veröffentlichungsdatum: 20. August 1998 (20.08.98) |

(21) Internationales Aktenzeichen: PCT/CH98/00015

(22) Internationales Anmeldedatum: 20. Januar 1998 (20.01.98)

(30) Prioritätsdaten:
325/97 14. Februar 1997 (14.02.97) CH

(71) Anmelder (für alle Bestimmungsstaaten ausser US): FERAG
AG [CH/CH]; Zürichstrasse 74, CH-8340 Hinwil (CH).

(72) Erfinder; und

(75) Erfinder/Anmelder (nur für US): JAEGER, Erich [CH/CH];
Laubgasse 6a, CH-8500 Frauenfeld (CH).

(74) Anwalt: PATENTANWÄLTE SCHAAD, BALASS, MENZL
& PARTNER AG; Dufourstrasse 101, Postfach, CH-8034
Zürich (CH).

(81) Bestimmungsstaaten: AL, AM, AT, AU, AZ, BA, BB, BG, BR, BY, CA, CH, CN, CU, CZ, DE, DK, EE, ES, FI, GB, GE, GH, GM, GW, HU, ID, IL, IS, JP, KE, KG, KP, KR, KZ, LC, LK, LR, LS, LT, LU, LV, MD, MG, MK, MN, MW, MX, NO, NZ, PL, PT, RO, RU, SD, SE, SG, SI, SK, SL, TJ, TM, TR, TT, UA, UG, US, UZ, VN, YU, ZW, ARIPO Patent (GH, GM, KE, LS, MW, SD, SZ, UG, ZW), eurasisches Patent (AM, AZ, BY, KG, KZ, MD, RU, TJ, TM), europäisches Patent (AT, BE, CH, DE, DK, ES, FI, FR, GB, GR, IE, IT, LU, MC, NL, PT, SE), OAPI Patent (BF, BJ, CF, CG, CI, CM, GA, GN, ML, MR, NE, SN, TD, TG).

Veröffentlicht

Mit internationalem Recherchenbericht.

(54) Title: DEVICE FOR PRODUCING PRINTED MATERIALS IN SEVERAL PARTS

(54) Bezeichnung: VORRICHTUNG ZUM HERSTELLEN VON MEHRTEILIGEN DRUCKEREIPRODUKTEN

(57) Abstract

A processing channel aligned with respect to a continuous, upwardly open transport channel (1) is arranged above the transport channel (1). The transport channel (1) determines together with the processing channel (2) a processing path, along which are arranged successive supply stations (11-17) for supplying the printed material parts (A to G). The processing channel (2) has individual, successive processing zones (3-10) between which are provided passages (18, 19, 119, 20, 120) through which the printed material parts (A to G) located in the processing channel (2) can reach the underlying transport channel (1). The printed material parts (A to G) are opened or deflected to one or another side during their transport between one processing zone to the next processing zone (3-10). Depending on the design of the processing zones (3-10) and on the arrangement of the passages (18, 19, 119, 20, 120), the inner parts (B to G) are arranged in a particular manner in the end printed material (P), either next to or inside one another.

(57) Zusammenfassung

Oberhalb eines durchgehenden, nach oben offenen Förderkanals (1) ist ein Verarbeitungskanal (2) angeordnet, der auf den Förderkanal (1) ausgerichtet ist. Der Förderkanal (1) zusammen mit dem Verarbeitungskanal (2) legt einen Verarbeitungsweg fest. Entlang dieses Verarbeitungsweges sind hintereinander Zuführstellen (11-17) zum Zuführen der Produktteile (A bis G) angeordnet. Der Verarbeitungskanal (2) weist einzelne, aufeinanderfolgende Verarbeitungsbereiche (3-10) auf. Zwischen einzelnen Verarbeitungsbereichen sind Durchgänge (18, 19, 119, 20, 120) vorgesehen, durch die die sich im Verarbeitungskanal (2) befindenden Produktteile (A bis G) in den darunterliegenden Förderkanal (1) gelangen können. Die von einem Verarbeitungsbereich zum nächsten Verarbeitungsbereich geförderten Produktteile (A bis G) werden im Übergang zwischen den Verarbeitungsbereichen (3-10) geöffnet oder nach der einen oder anderen Seite umgelenkt. Abhängig von der Ausbildung der Verarbeitungsbereiche (3-10) und der Anordnung der Durchgänge (18, 19, 119, 20, 120) liegen im Endprodukt (P) die Innenteile (B bis G) in einer bestimmten gegenseitigen Anordnung nebeneinander oder ineinander.

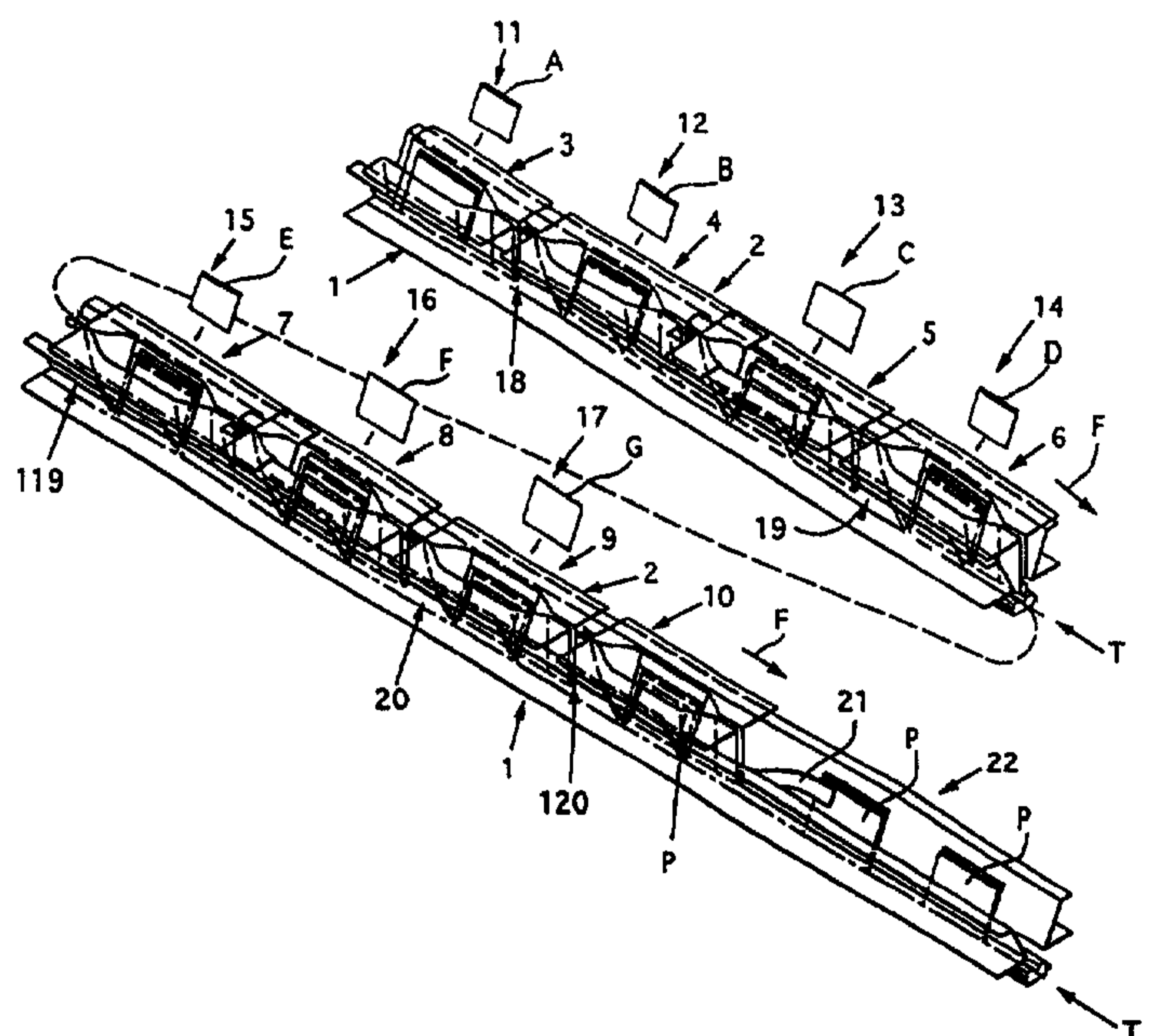

Apparatus for producing multi-part printed products

The present invention relates to an apparatus for producing multi-part printed products which
5 comprise a folded outer part and a number of inner parts arranged within the outer part.

In the case of known apparatuses of this type for producing multi-part printed products
10 (EP-A-0 346 579 and the corresponding US-A-5,116,033), a first folded product part, which serves as outer part, is introduced, at a first supply location, into the conveying channel and advanced along said conveying channel. The first product part is opened along the
15 advancement route from the first supply location to the following, second supply location. At the second supply location, a second product part (inner part) is introduced into the open first product part. At the further, following supply locations, further product
20 parts (inner parts) are introduced one after the other into the open first product part. In this case, said inner parts come to rest one beside the other or one inside the other, the respective inner parts in the last-mentioned case being opened before the next inner
25 part is introduced. This results in an end product in the case of which a number of folded or non-folded inner parts are positioned in the first product part, which serves as outer part.

The object of the present invention, then, is
30 to provide an apparatus of the type mentioned in the introduction which allows more freedom in putting together the end printed product, i.e. more freedom in the mutual arrangement of the inner parts in the outer part, than do the apparatuses known hitherto.

35

As long as the product parts are located in the processing channel, they are accessible for

WO 98/35901

- 2 -

PCT/CH98/00015

manipulations such as opening and deflecting to one side or the other of the processing or conveying channel. This makes it possible, together with the specific transfer of the product parts from the processing channel into the conveying channel therebeneath, to influence the position of the inner product parts in relation to the outer part, on the one hand, and in relation to the other inner parts, on the other hand.

10

An exemplary embodiment of the apparatus according to the invention is explained in more detail hereinbelow with reference to the drawings, in which, purely schematically and in simplified illustrations:

Figure 1 shows, in perspective, an apparatus for producing multi-part printed products,

Figures 2-18 show, in a perspective illustration and in section in each case, the various successive processing regions of the apparatus according to Figure 1,

Figure 19 shows, on a larger scale than Figure 18, a cross section through a finished end printed product located in the conveying channel,

Figures 20-23 each show a perspective illustration of various transitions from one processing region into the following processing region of the apparatus,

Figure 24 shows a longitudinal section of a portion of the apparatus according to Figure 1,

Figures 25 and 26 each show a plan view of the processing channel in the transition from one processing region to the following processing region as a product part is deflected laterally,

Figures 27 and 28 each show a plan view of the processing channel in the transition from one processing region to the following processing region as a product part is opened, and

Figures 29-31 show a plan view of another embodiment of an opening arrangement.

Figure 1 shows a perspective, simplified illustration of an apparatus by means of which multi-part printed products, e.g. newspapers and periodicals, which comprise an outer part (cover) and inner parts inserted therein, can be produced. This apparatus, which, for space reasons, is illustrated in subdivided form in Figure 1, has a continuous conveying channel 1 which is closed at the bottom, is open toward the top and, in the case of the exemplary embodiment shown, runs essentially rectilinearly and defines a processing route. Said conveying channel 1 is V-shaped in cross section. Arranged above the conveying channel 1, and such that it engages therein, is a processing channel 2 which is open toward the top and also extends in the direction of the processing route. The processing channel 2 is divided into successive processing regions 3 to 10. Supply locations 11 to 17 (not illustrated any more specifically in design terms) are provided one behind the other along the processing route. A folded product part A (main product), which forms the outer part of the finished printed product, is supplied at the supply location 11. The inner product parts B to G are supplied, and positioned in the outer part A in a manner which is still to be described, at the supply locations 12-17. In the case of the present exemplary embodiment, the inner parts B, D, E are folded product parts (preprinted products), while the inner parts C, F, G are single-part product parts (inserts).

The product parts located in the conveying channel 1 are advanced in the direction of the arrow F by means of a conveying arrangement T. An advancement device (not shown in Figure 1) is provided in order to advance the product parts located in the processing channel 2.

Provided in the processing channel 2, between certain processing regions, are through-passages which allow the product parts to be transferred downward from

WO 98/35901

- 4 -

PCT/CH98/00015

the processing channel 2 into the conveying channel 1. There is thus provided, in the exemplary embodiment shown, a through-passage 18 between the processing regions 3 and 4, a through-passage 19 between the processing regions 5 and 6, a through-passage 119 between the processing regions 6 and 7, a through-passage 20 between the processing regions 8 and 9 and a through-passage 120 between the processing regions 9 and 10. In the processing region 10 - although possible per se - no further product part is introduced into the still open end product P. At the end of this processing region 10, the finished end product P is closed by means of a diverting element 21 and positioned against one wall of the conveying channel 1. The closed end product P may then be removed from the conveying channel 1 in the end region 22 of the latter or be conveyed further along the conveying channel 1 to a processing station. It is also possible for the end product P, after leaving the processing region 10, to be conveyed further in the conveying channel 1, for example to a processing station, in the open state.

The construction of the apparatus shown in Figure 1 and the operation of the same will now be explained in more detail with reference to Figures 2-23, the designations which are used in Figure 1 also being used for Figures 2-23.

Figures 2-4 show the first processing region 3 in a perspective illustration (Figure 2), in a view in the direction of the arrow III in Figure 2 (Figure 3) and in section along line IV-IV in Figure 2 (Figure 4). The conveying channel 1, which as has already been mentioned is V-shaped in cross section, has two oblique walls 23 and 24. These walls 23, 24 are subdivided into a fixed wall part 23a, 24a and a moving wall part 23b, 24b. The wall parts 23b, 24b form part of the conveying arrangement T (which otherwise is not illustrated any more specifically). In the region of the supply locations 11-17, the processing channel 2, which runs above the conveying channel 1 and is aligned

WO 98/35901

- 5 -

PCT/CH98/00015

therewith, likewise has a V-shaped cross section. The obliquely inclined side walls of the processing channel 2 are designated by 25 and 26.

The conveying arrangement T also contains
5 carry-along elements 27, 28 (Figure 3) which project into the conveying channel 1 and are fastened in pairs at regular intervals opposite one another on the moving wall parts 23b, 24b. For reasons of clarity, these carry-along elements 27, 28 are not shown in the
10 following figures. Connected to the moving wall part 24a and/or to the carry-along elements 28 are fingers 29 which project into the processing channel 2 and belong to the advancement arrangement 30, which has already been mentioned in conjunction with Figure 1.
15 Said advancement arrangements serve for advancing in the conveying direction F product parts which are located in the processing channel 2. The fingers 29 are arranged, in the same way as the carry-along elements 27, 28, at regular intervals and are moved in
20 the conveying direction F, i.e. in the direction of the processing route.

The processing region 3 has - in the same way as the other processing regions 4-9 - an input part 31, which is adjoined in the conveying direction F by an
25 aligning part 32. The product parts A to G are introduced into the input part 31 of the processing channel 2 in each case at the supply locations 11-17. By means of the aligning parts 32, the product parts which are input into the input part 31 are aligned,
30 i.e. moved into an essentially vertical position, as is illustrated in Figure 3 by the chain-dotted product part A. The product part leaving the aligning part 32 thus assumes a defined position as it runs into the respectively following processing region, which
35 facilitates the further manipulations.

As Figures 2-4 show, the folded product part A is introduced into the processing channel 2 in the processing region 3, i.e. at the supply location 11. Said product part A forms the outer part of the

WO 98/35901

- 6 -

PCT/CH98/00015

finished end product and comprises two product halves A1 and A2, of which the product half A2 projects beyond the product part A1. The projecting portion of the product half A2 is designated by 33 and is referred to
5 by specialists as an overfold. As Figures 2-4 show, the still closed product part A butts against the wall 26 of the processing channel 2.

Figures 5-7 show the following processing regions 4 and 5 in perspective (Figure 5) and in
10 section along lines VI-VI and VII-VII in Figure 5. The processing region 4 has an opening part 34 which is arranged upstream of the input part 31 and is directed toward the aligning part 32 of the preceding processing region 3. Said opening part 34 is followed by a
15 directing part 35, which is designed here as a spreading part and has two directing walls 35a and 35b which diverge in the conveying direction F. As Figure 20 shows, the product part A runs toward the opening part 34 as it leaves the aligning part 32 of the
20 processing region 3, and said opening part comes to act on the projecting portion 33 of the product half A2 and, together with the directing part 35, causes the product part A to open i.e. causes the product halves A1 and A2 to spread apart from one another. The
25 product part A opens here in a manner known per se, as is described in more detail, for example, in EP-A-0 080 185 and the corresponding US-A-4,486,011. The open product part A passes through the through-passage 18 between the processing regions 3 and 4 and
30 passes into the conveying channel 1 located therebeneath, as Figures 6 and 7 show. In this case, the product half A1 butts against the wall 23, and the product half A2 butts against the wall 24, of the conveying channel 1. The product part A, which was
35 previously advanced by a finger 29 of the advancement arrangement 30, is then advanced along the conveying channel 1 by the carry-along elements 27 and 28.

The product part B is introduced into the input part 31 of the advancement channel 2 in the processing

WO 98/35901

- 7 -

PCT/CH98/00015

region 4, at the supply location 12. As has been mentioned, said product part B is likewise folded and, in the same way as the product part A, has two product halves B1 and B2, of which the product part B2 has a projecting portion 33. The closed product part B, butting against the wall 26, is advanced by the advancement arrangement 30, runs through the adjoining aligning part 32 and, in the same way as has been described with reference to the product part A, is opened by means of the opening part 34 and a directing part 35' as was shown in more detail in Figure 21. The directing part 35' is inserted into the advancement channel 2. The directing walls 35a', 35b' of said directing part 35' form a through-passage gap with the walls 25, 26 of the advancement channel 2. In contrast to the product part A, however, the open product part B runs further in the advancement channel 2 and passes behind the directing walls 35a', 35b' of the directing part 35' to the input part 31 of the next processing region 5. In this processing region 5, the product part C is positioned in the open product part B, as can be seen from the right-hand part of Figure 5 and from Figure 7. The first product part A is located in the conveying channel 1 and the product parts B and C are located in the advancement channel 2 above the product part A (see Figure 7).

In Figures 8 and 9, the next processing region 6 is shown in perspective and in section along line IX-IX in Figure 8. At its inlet, said processing region has a diverting part 36 which is directed toward the aligning part 32 of the preceding processing region 5. Said diverting part 36 is adjoined by a directing part 35, which in this case serves as a deflecting part. As they are advanced, the product parts B and C run through the aligning part 32 of the processing region 5, which results in the product part B being closed. The product parts B and C are deflected to the left, as seen in the conveying direction F, by the diverting part 36 of the following processing region 6,

as can be seen from Figure 22. At the same time, the product part B, with the product part C inserted therein, passes downward through the through-passage 19 and drops into the open product part A. In this case, 5 the directing wall 35b of the directing part 35 ensures that the product parts B and C are tilted to the left and come to rest on the product half A2, as can be seen from Figure 9.

10 The product part D, which is folded in the same way as the product parts A and B, is positioned in the input part 31 of the processing region 6 at the supply location 14. In this case, the product half D2 likewise has a projecting portion 33.

15 The product part D, which is introduced into the processing channel 2 in the closed state (Figure 9), is conveyed further through the adjoining aligning part 32 (Figure 8) and runs toward the opening part 34 of the following processing region 7 (Figure 10). In this case, the product part D is opened, by means of 20 the opening part 34 and the directing part 35, as has already been explained in conjunction with the product part A. The open product part D passes downward through the through-passage 119 into the conveying channel 1. As can be seen from Figures 11 and 12, in 25 which the processing regions 7 and 8 are shown in section along lines XI-XI and XII-XII, respectively, in Figure 10, the product half D1 of the product part D comes to rest on the product half A1 of the product part A, while the other product half D2 comes to rest 30 on the closed product part B.

Figures 10-12 show, as has already been mentioned, the two processing regions 7 and 8, which are of a similar construction to the processing regions 4 and 5 according to Figures 5-7. The folded product 35 part E is introduced into the input part 31 of the processing region 7 at the supply location 15. Said product part has two product halves E1 and E2, the product half E2 projecting beyond the product half E1. The projecting portion of the product half E2 is

designated by 33. Once the product part E has been introduced into the input part 31 of the processing region 7, the closed product part E butts against the side wall 26 of the processing channel 2 (Figure 11).
5 As it is conveyed further by a finger 29 of the advancement arrangement 30, the closed product part E runs through the adjoining aligning part 32 and passes to the opening part 34 of the following processing region 8. As has been described with reference to
10 Figures 5-7, the product part E is opened by the opening part 34 and the adjoining directing part 35' and remains in the advancement channel 2. In the input part 31 of the processing region 8, the product half E1 of the product part E butts against the wall 25, and
15 the product half E2 butts against the wall 26, of the processing channel 2, as Figure 12 shows. The next product part F (insert) is then introduced into the open product part E at the supply location 16 and positioned on the product half E2, as can likewise be
20 seen from Figure 12. Located beneath the two product parts E and L [sic], in the conveying channel 1, are the open product part A, the closed product part B, with the product part C located in the interior of the latter, and the open product part D, which rests on the
25 product half A1 of the product part A by way of the product half D1 and on the product half B2 of the product part B by way of the other product half D2, as can be seen from Figures 11 and 12.

Figures 13 and 14 show the processing region 9
30 in a perspective illustration and in section along the line XIV-XIV of Figure 13. This input portion 9 has a diverting part 36 directed toward the aligning part 32 of the preceding processing region 8. The closed product part E with inner product part F, which is
35 leaving the aligning part 32 of the processing region 8, is deflected to the right, as seen in the conveying direction F, by the diverting part 36 of the processing region 9, as can be seen from Figure 23. In this case, the product parts E and F are guided by the directing

WO 98/35901

- 10 -

PCT/CH98/00015

wall 35a of the directing part 35. The two product parts E and F pass through the through-passage 20 between the processing regions 8 and 9 and pass into the guide channel 1 located therebeneath, where they
5 come to rest on the product half D1 of the open product part D (see Figure 14).

The last product part G, which in the present exemplary embodiment is defined as a non-folded insert, is introduced into the input part 31 of the processing
10 region 9 at the supply location 17. The product part G comes into abutment against the wall 26 of the advancement channel 2, as Figure 14 shows. As can also be seen from Figure 14, the product parts A to F are located beneath the product part G in the conveying
15 channel 1.

The product parts A to F and the product part G are advanced further in the direction of the arrow F by the conveying arrangement T and by the advancement arrangement 30, respectively. In this case, the
20 product part G runs through the aligning part 32 of the processing region 9 and is then deflected to the left, as seen in the conveying direction F, by the diverting part 36 of the last processing region 10 (see Figures 15 and 16). In addition, the product part G is guided
25 downward, through the through-passage 120 between the processing regions 9 and 10, into the conveying channel 1. As shown [sic] from Figure 16, which constitutes a section along line XVI-XVI in Figure 15, the product part G, which as has been mentioned is deflected to the
30 left, comes to rest on the product half D2 of the product part D.

No further product parts are supplied in this last processing region 10. The processing region 10 thus does not have an input part 31. The latter is
35 replaced by a guide part 37 (Figure 15), of which obliquely downwardly sloping walls 37a, 37b correspond to the side walls 25, 26 of the advancement channel 2. The processing region 10 may thus be of the same design as, for example, the processing region 6 (Figure 8).

The definitively put-together end product P, which is located in the processing region 10 in the conveying channel 1, is still open and is guided past the diverting element 21 as it is advanced further by the conveying arrangement T. This diverting element 21 closes the end product P and positions it against the left-hand side wall 24 of the conveying channel 1, as seen in the conveying direction F. Figure 17 and Figure 18, which constitutes [sic] a section along line XVIII-XVIII in Figure 17, show the finished printed product P butting against the side wall 24 of the conveying channel 1 in the end region 22.

The composition of the finished end product P can be seen from Figure 19 which constitutes a detail of Figure 18 on an enlarged scale. The outer part (cover) of the end product P is formed by the product part A. All the other product parts (inner parts) B to G are located between the product halves A1 and A2 of the folded outer part A. The product half A2 has adjacent to it the folded product part B, in the interior of which the product part C is located. Butting against the product half B1 of the product part B is the product half D2 of the folded product part D, which serves as a cover for the product parts E, F and G. The product part F is located in the interior of the folded product part E. The product part G is arranged between the product half D2 and the product half E2 of the product parts D and E. The end product part P thus comprises, on the one hand, product parts inserted one inside the other and, on the other hand, product parts located one beside the other, it being the case that the position of the individual product parts, i.e. in the illustration of Figure 19 the sequence of the product parts from left to right, is determined by the design of the processing channel 2, more specifically by the arrangement of the through-passages between the processing regions 3-10 and the arrangement and design of the opening part 34 and of the diverting parts 36.

It can readily be seen, from what has been said above, that it is possible to change the composition of the end product P, i.e. the arrangement of the inner parts in the outer parts, with few modifications in the processing channel 2, namely by way of a different arrangement of the through-passages between the processing regions and/or by exchanging an opening part 34 for a diverting part 36 and vice versa and changing over the diverting direction of the diverting parts 36 (to the left or to the right).

The sectional Figure 24, then, will be used to explain in more detail the configuration of the conveying and processing channels 1, 2 in the region of a transition from a processing region designated by 38 to the following processing region, designated by 39.

The product part located in the conveying channel 1 is designated by 40 and is advanced by the conveying arrangement T. In this case, the carry-along element 27 acts on the trailing edge of the product part 40. Located in the processing channel 2 is a product part which is designated by 41 and is illustrated as a two-part, folded product part with a projecting portion 33. In order to advance said product part 41, use is made of a finger 29 of the advancement arrangement 30. Said finger 29 likewise acts on the trailing edge of the product part 41. As can be seen from Figure 24, the finger 29 of the advancement arrangement 30 is offset in relation to the carry-along element 27 of the conveying arrangement T by the distance a, to be precise it is offset forward as seen in the conveying direction F. This measure ensures that the product part 41 does not come to rest on the carry-along element 27 of the conveying arrangement T once it has run through the through-passage 42 between the processing regions 38 and 39 and has dropped downward into the conveying channel 1. This ensures that the product part 41 is carried along by the conveying arrangement T.

Figure 24 shows that the base 43 of the processing channel 2 may be inclined downward in the conveying direction F, in order to facilitate transfer of the product part 41 into the conveying channel 1. The through-passage 42 formed between that end of the processing region 38 of the processing channel 2 which is designated by 44 and the directing part 35 of the next processing region 39. The opening part 34 or the diverting part 36 is arranged upstream of the directing part 35, as seen in the conveying direction F. The opening part 34 may be designed, for example, as shown in Figures 5-10. It is indicated in Figure 24 that the opening part 34 may also be designed as a so-called vacuum opener 34', which subjects one product half to negative pressure in a known manner.

Figures 25-28 show plan views in each case of the product part 41 of Figure 24 in the transition from the processing region 38 into the adjoining processing region 39. In the case of Figures 25 and 26, the processing region 39 has a directing part 36 [sic], which deflects the product part 41 either to the left (Figure 25) or to the right (Figure 26), as seen in the conveying direction F. In one case, the product part 41 is guided along the directing wall 35b, and in the other case it is guided along the other directing wall 35a, of the directing part 35.

In the illustration of Figures 27 and 28, the processing region 39 is provided on the inlet side with an opening part 34, which acts on the projecting portion 33 of one product half 41b or 41a of the product part 41. In the illustration of Figure 27, the left-hand product half 41, as seen in the conveying direction F, is provided with the projecting portion 33, while, in the illustration of Figure 28, the right-hand product half 41a has the projecting portion 33. Accordingly, the position of the opening part 34 in relation to the following directing part 35 differs in Figures 27 and 28.

Figures 29-31 illustrate a different embodiment of an opening part 34 in various operating phases, corresponding parts being provided with the same designations as in the preceding figures.

5 Figure 29, which shows the opening part 34 in the rest state, best shows the construction of said opening part 34. The opening part 34 has two thin directing plates 45 and 46 which extend in the conveying direction F, are located opposite one another
10 and consist of a resilient material, e.g. of spring steel. Said directing plates 45, 46 are fastened on a mount 47 at their end which is directed toward the aligning part 32 of the preceding processing region. At the other, free end, 45a, 46a, the directing plates
15 45, 46 are bent outward, i.e. away from the opposite directing plate. The mount 47 is fitted on a stationary component of the adjoining processing region via a support 48. Connected to each directing plate 45, 46 is a nozzle head 49 or 50, which is connected to
20 a compressed-air source (not illustrated specifically). The nozzle heads 49 and 50 do not have compressed air admitted to them in the illustration according to Figure 29. The two directing plates 45 and 46 are located in their basic position, in which they run
25 approximately parallel to one another in the conveying direction F.

If the nozzle heads 49, 50 are connected to compressed-air source, then the air passing out of the nozzle heads 49, 50 flows along the directing plates
30 45, 46, to be precise on the side which is directed toward the other directing plate in each case. This then results in the directing plates 45, 46 moving toward one another and coming into abutment against one another, as is shown in Figure 30. This type of
35 operation is known as the "Coanda effect".

Figure 31, then, shows the way in which the opening operation progresses.

Once it has left the aligning part 32 of the preceding processing region, the product part 41 which

WO 98/35901

- 15 -

PCT/CH98/00015

is to be opened passes between the directing plates 45, 46 and is moved past said directing plates 45, 46 in the conveying direction F. The air which continues to flow along the directing plates 45, 46 positions the product halves 41a and 41b against the directing plates 45, 46. Since the directing plates 45, 46 are bent outward at their free end 45a, 46a, and thus diverge from one another, the product halves 41a and 41b are lifted off from one another, as Figure 31 shows. The product part 41, which is open in this way in the region of the leading edge, is transported further to the directing part 35. The two product halves 41a and 41b are laterally guided past the directing part 35, which, as has already been explained, results in the product 41 being opened fully.

With an opening part 34 according to Figures 29-31, in the case of which the Coanda effect is used, it is not necessary for one of the two product halves to be provided with a projecting portion 33.

A number of variants will now additionally be pointed out hereinbelow.

Both the outer part A and the inner parts B, D and E may comprise two or more folded sheets located one inside the other.

It is also conceivable for opening means or diverting means for respectively opening or diverting the end product P also to be provided in the conveying channel 1 downstream of the processing region 10.

It is also possible to provide along the processing route, between the supply locations 11-17 or downstream of the latter, processing stations, e.g. cutting or stitching stations, for respectively trimming or wire stitching of certain product parts or the end product part P, or adhesive-bonding stations, at which the product parts supplied are connected to other product parts by means of adhesive.

On the other hand, it is possible to dispense with diverting parts 36 if the product parts, rather than being in the vertical position as shown, are

WO 98/35901

- 16 -

PCT/CH98/00015

5 already in an oblique position, i.e. inclined to the left or right, as they pass out of a processing region. In this case too, the directing parts 35 ensure that the product part maintains its oblique position through the processing region.

10 The conveying channel 1 and thus also the advancement channel 2 may also have, rather than the rectilinear progression shown, a wholly or partially curved progression and also define a continuous processing route.

15 The apparatus described may be constructed differently, depending on the desired composition of the end product. By virtue of an appropriate configuration of the processing regions, i.e. of the mutual arrangement and design of the opening parts 34, of the directing parts 35, 35' and of the diverting parts 36 and also of the input parts 31, it is possible to select the type of end product and the arrangement of the product parts within extremely wide limits. It is thus possible, in particular, to produce end products merely by way of insertion of the product parts in each case into the open, previously supplied product part, this corresponding to collection from the outside to the inside. In addition, with a suitable configuration of the apparatus described, it is also possible to produce end products in which the product parts are located one beside the other (collation). Such an end product, then, does not have an outer product part (cover) in which the other product parts are positioned. However, it is also possible to produce such an end product, formed by collation, in which, with folded product parts, a further product part is inserted into all of these folded product parts, or into some of these individually. Such an end product would be provided, for example, if in the illustration of Figure 11, with no product part A, the product parts B, C, D located in the conveying channel 1 were to form the end product.

20

25

30

35

- 17 -

What is claimed is:

1. An apparatus for producing multi-part printed products which comprise a folded outer part and a number of inner parts arranged within the outer part,
5 comprising:
 - a continuous conveying channel which is open toward the top and which defines a processing route;
 - a conveying arrangement for conveying product parts along the conveying channel;
 - 10 a plurality of supply locations arranged one after the other along the processing route for supplying the outer part and the inner parts;
 - a processing channel arranged above and aligned with the conveying channel, and which is open toward the top
15 and has individual successive processing regions, of which at least some are provided with input parts for receiving the product parts supplied at the supply locations;
 - an advancement arrangement for advancing the product
20 parts along the processing channel; and
 - wherein through-passages are provided in the processing channel between certain successive processing regions which open toward the bottom and by means of which the product parts passing out of a processing
25 region are transferred into the conveying channel located therebeneath.
2. The apparatus according to claim 1, wherein the conveying channel is V-shaped in cross section.
3. The apparatus according to either one of claims 1 or
30 2, wherein the processing channel is V-shaped in cross section at least in the region of the input parts.

- 18 -

4. The apparatus according to any one of claims 1 to 3, wherein at least some of the processing regions are provided with opening parts for opening multi-leaf product parts.
- 5 5. The apparatus according to claim 4, wherein the opening parts are arranged in an initial section of the associated processing region as seen in the conveying direction of the product parts, and act on the product parts which have been introduced in the preceding
10 processing region as said product parts run past the opening part.
6. The apparatus according to either one of claims 4 or 5, wherein a directing part is arranged downstream of the opening part as seen in the conveying direction of the
15 product parts, and is arranged approximately centrally in the processing channel and configured for holding open or completely opening the product parts.
7. The apparatus according to any one of claims 1 to 6, wherein at least some of the processing regions are
20 provided with diverting parts for laterally deflecting the product parts.
8. The apparatus according to claim 7, wherein the diverting parts are arranged in an initial section of the associated processing region as seen in the conveying
25 direction of the product parts, and act on the product parts which have been introduced in the preceding processing region as said product parts run past the diverting part.

- 19 -

9. The apparatus according to either one of claims 7 or 8, wherein a directing part is arranged downstream of each diverting part as seen in the conveying direction of the product parts, and is arranged approximately
5 centrally in the processing channel and past which the product parts run laterally.

10. The apparatus according to any one of claims 4 to 9, wherein the processing regions have an aligning part which is arranged downstream of the input part as seen in
10 the conveying direction of the product parts, and through which the product parts run and are thus moved into a predetermined position.

11. The apparatus according to claim 10, wherein the aligning part which is arranged downstream of the input
15 part moves the product parts into an approximately vertical position, and the aligning part of a processing region and an opening part or a diverting part of the next-following processing region are aligned with one another.

20 12. The apparatus according to any one of claims 1 to 11, wherein the conveying arrangement and the advancement arrangement include conveying elements which act on the product parts located in the conveying channel and in the advancement channel, the conveying elements of the
25 conveying arrangement and the conveying elements of the advancement arrangement being driven synchronously.

- 20 -

13. The apparatus according to claim 4, wherein the opening part has two elongate directing elements which extend in the conveying direction of the product parts and define between them a through-path for the product parts which are to be opened, said elongate directing elements being elastically deflectable transversely to their longitudinal axes, and a compressed air outlet on at least one of the directing elements which is located on the side thereof which is directed toward the other directing element for delivering compressed air such that an air flow is produced along the directing elements.

14. The apparatus according to claim 13, wherein the two elongate directing elements are elastically deflectable at right angles to their longitudinal axes.

15. The apparatus according to either one of claims 13 or 14, wherein the elongate directing elements, at their front end as seen in the conveying direction of the product parts, are fastened on a mount and, at the other rear end, are curved in a direction which leads away from the other directing element.

16. The apparatus according to any one of claims 1 to 15, wherein a plurality of processing stations are arranged along the processing route at which the product parts are subjected to processing steps.

17. The apparatus according to claim 16, wherein said plurality of processing stations includes at least one station selected from the group consisting of: cutting, stitching and adhesive-bonding stations.

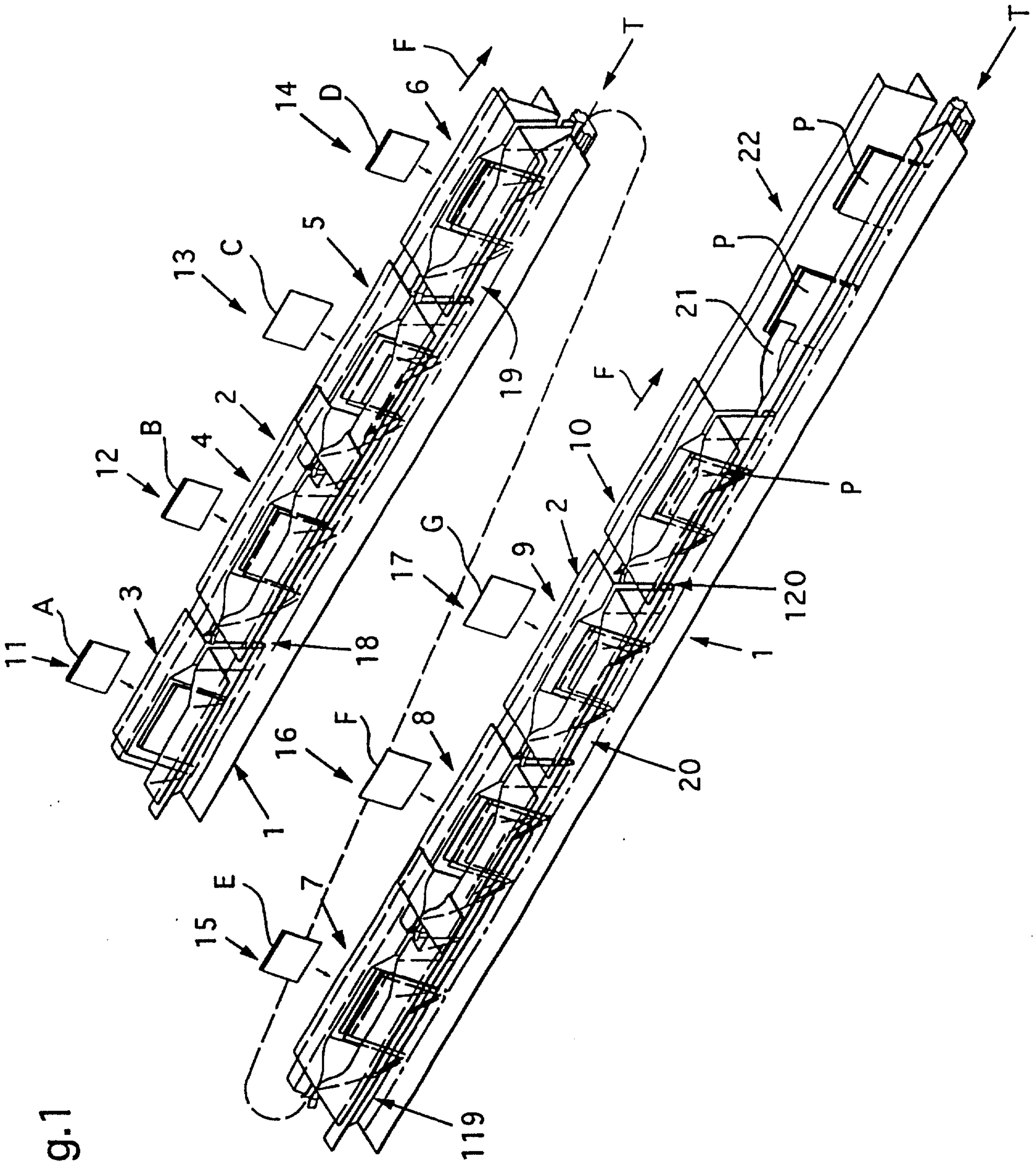

Fig. 1

Fig.8

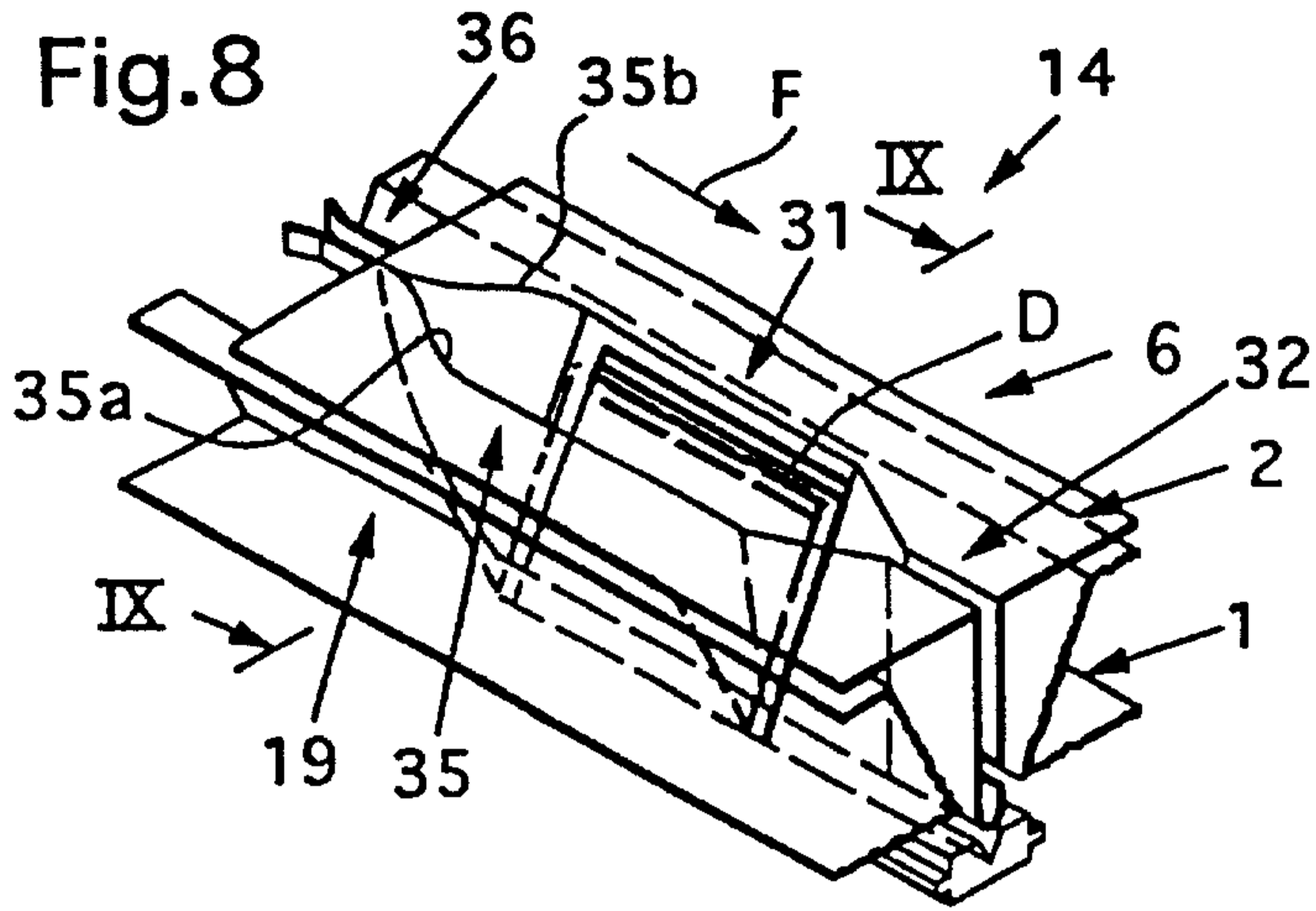

Fig.9

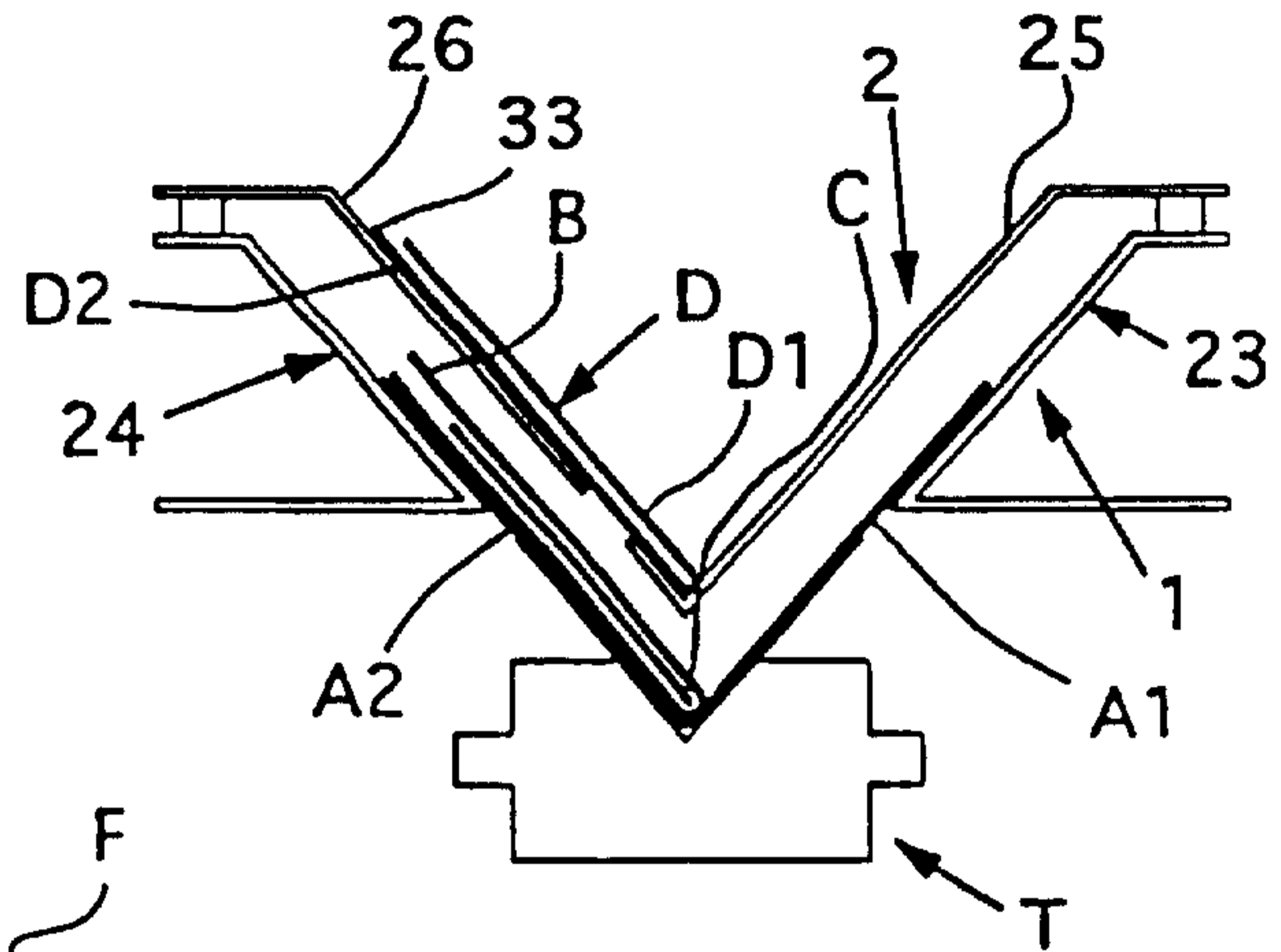

Fig.10

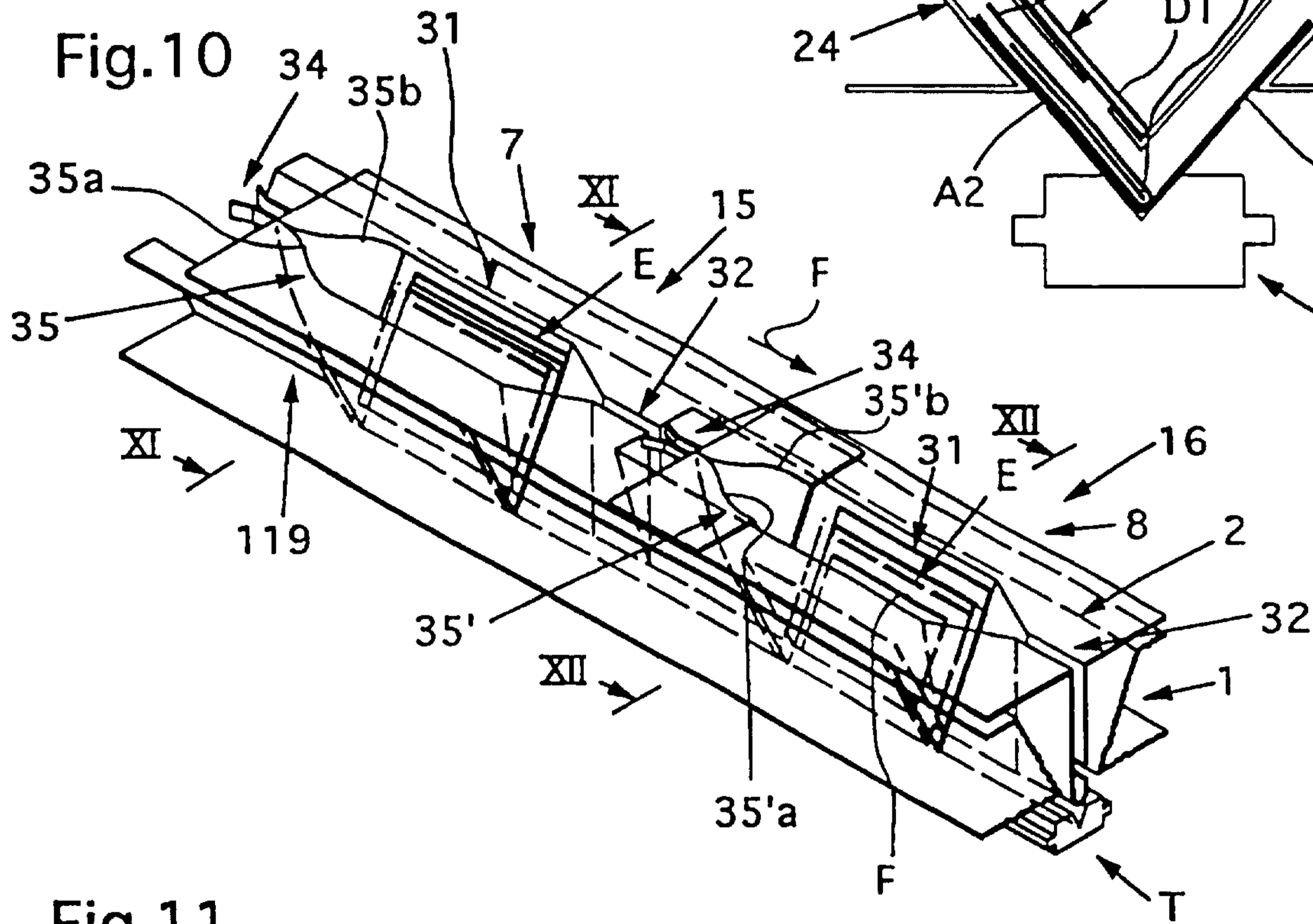

Fig.11

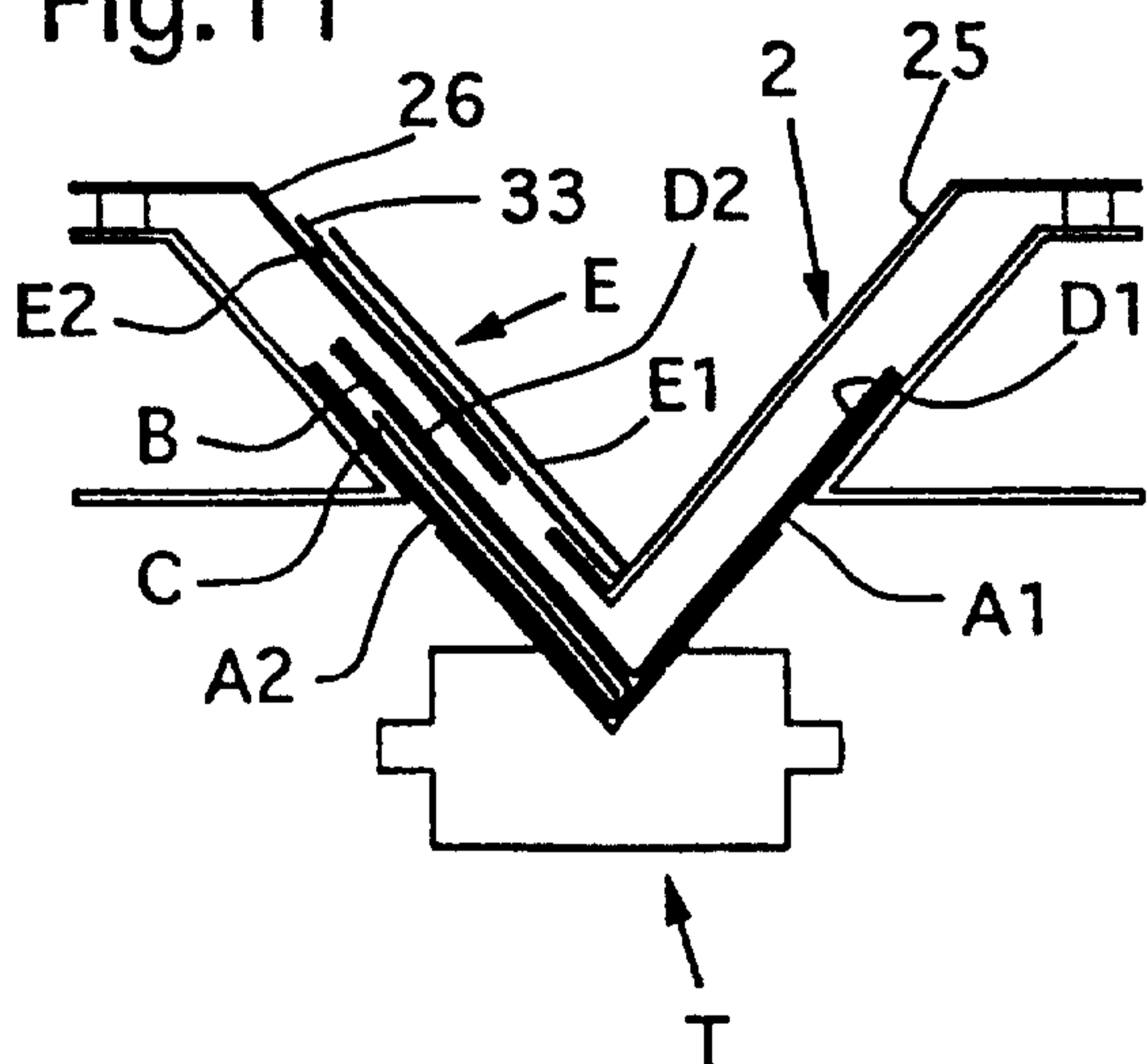

Fig.12

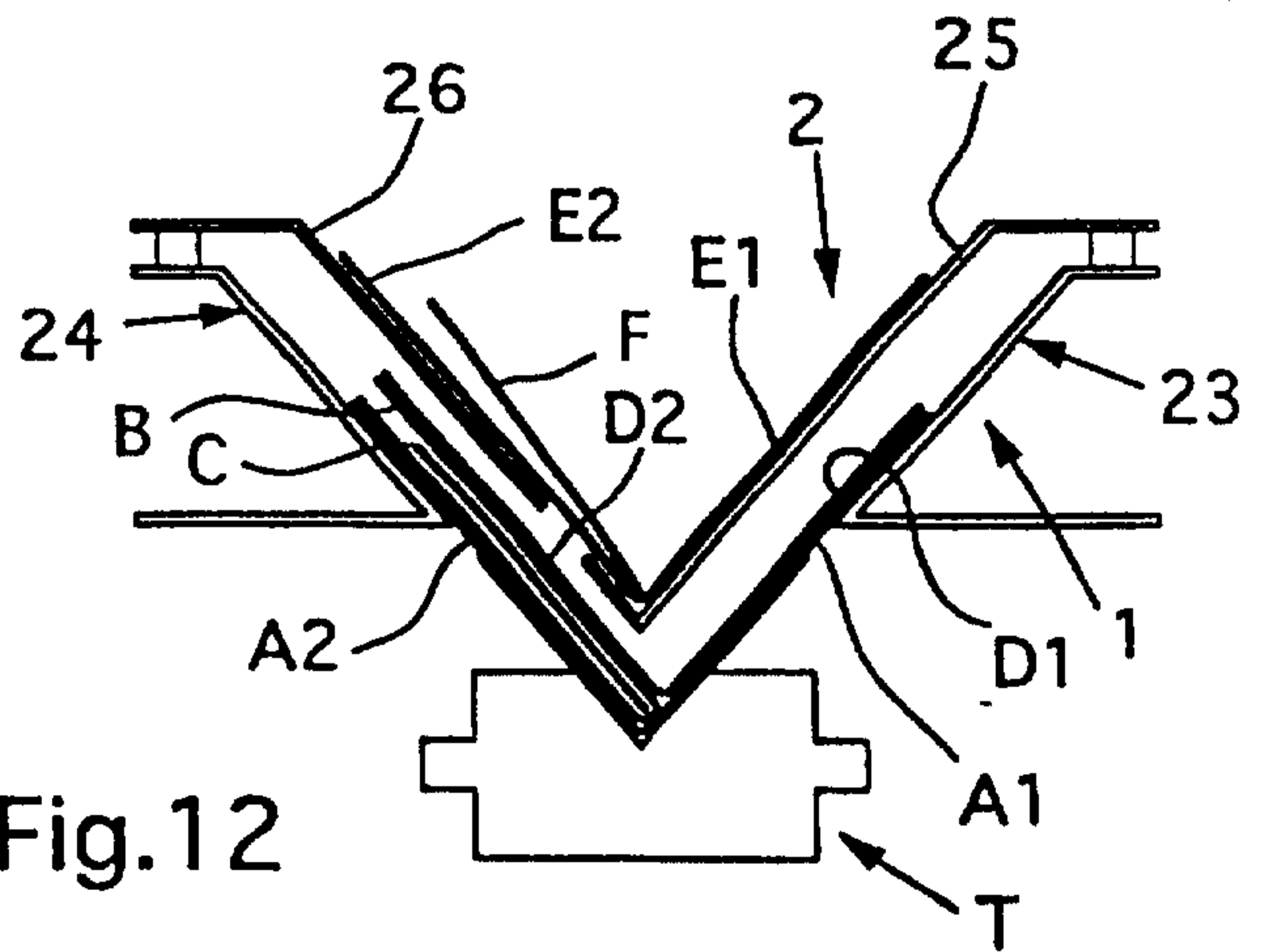

Fig.13

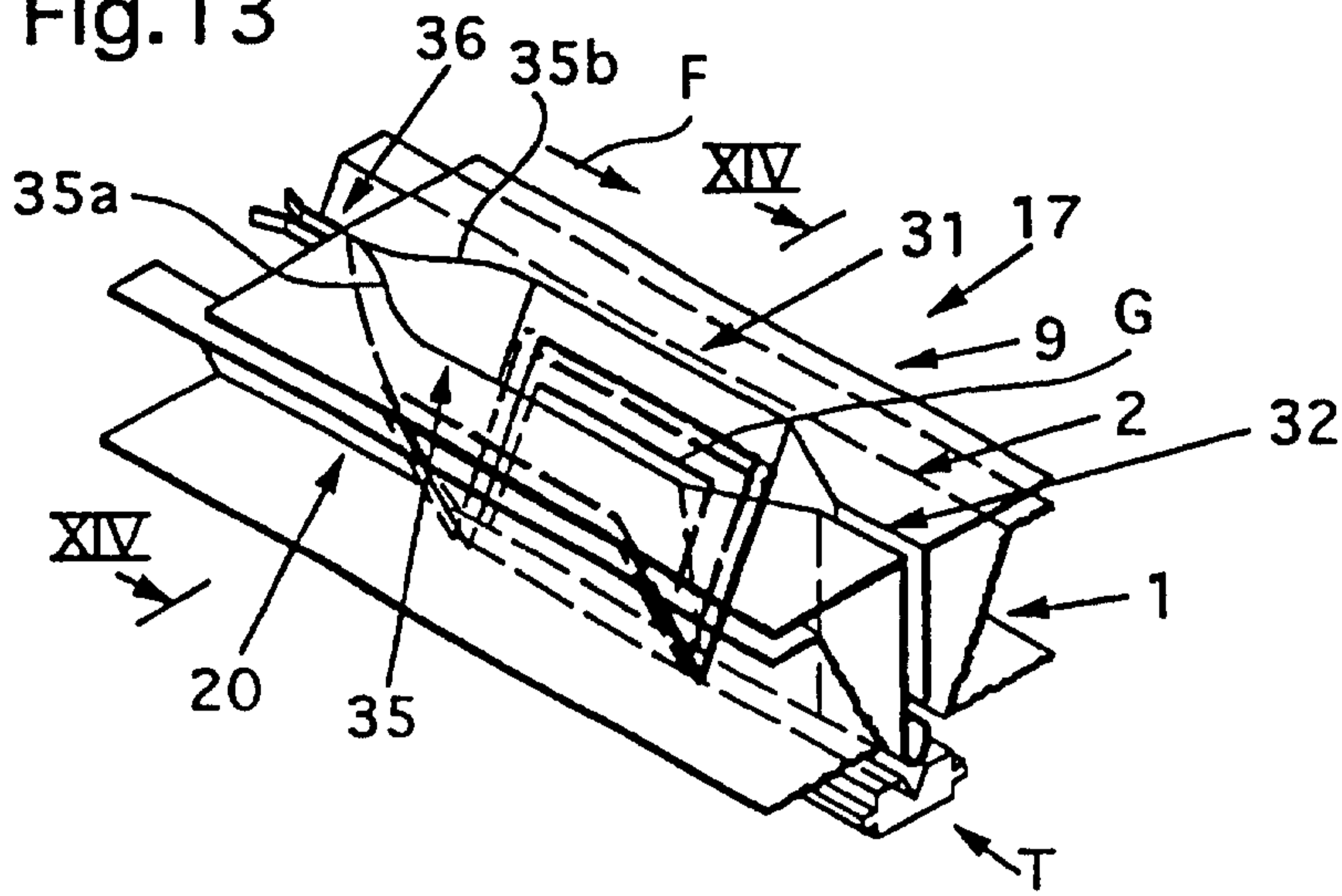

Fig.14

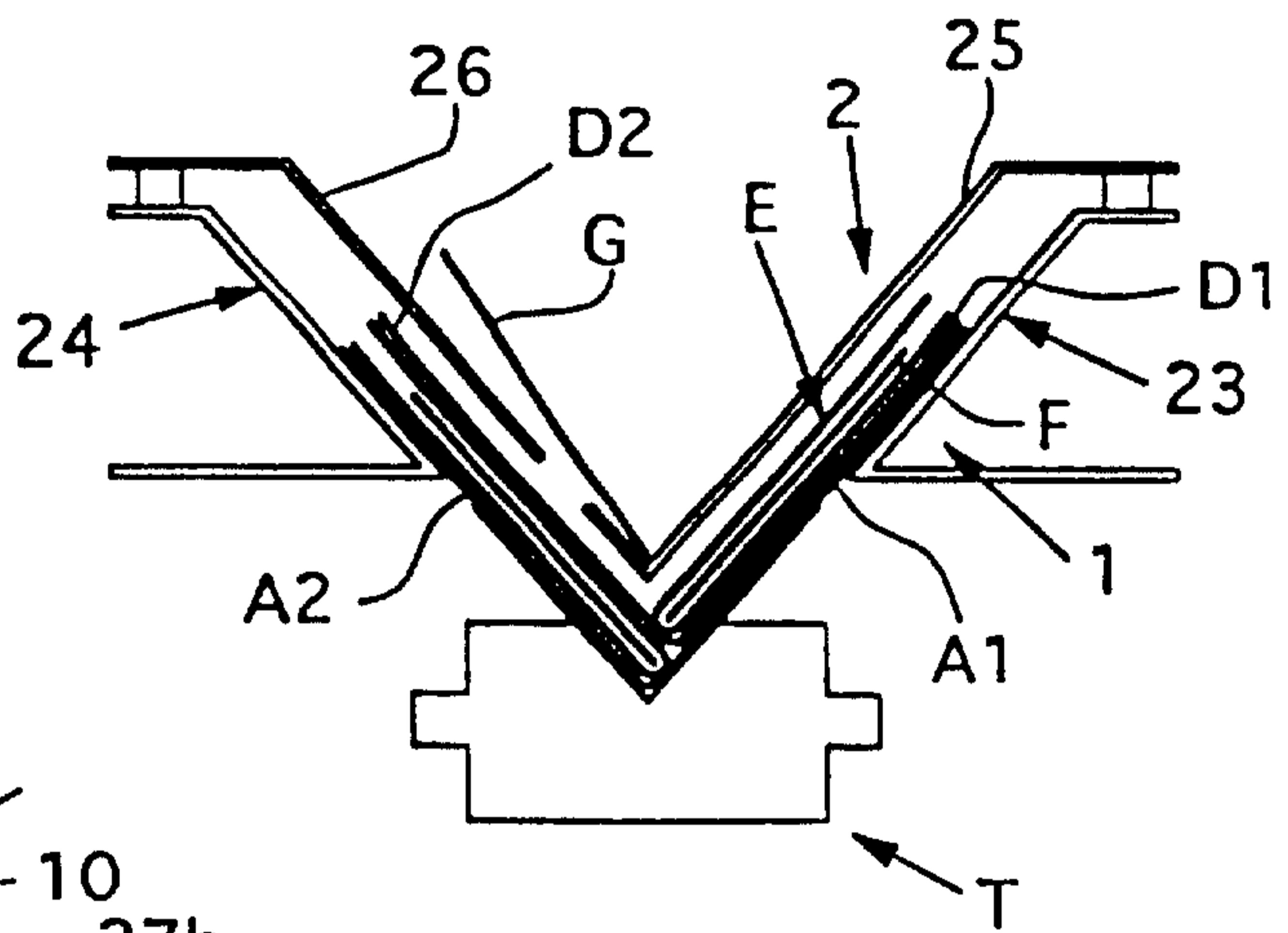

Fig.15

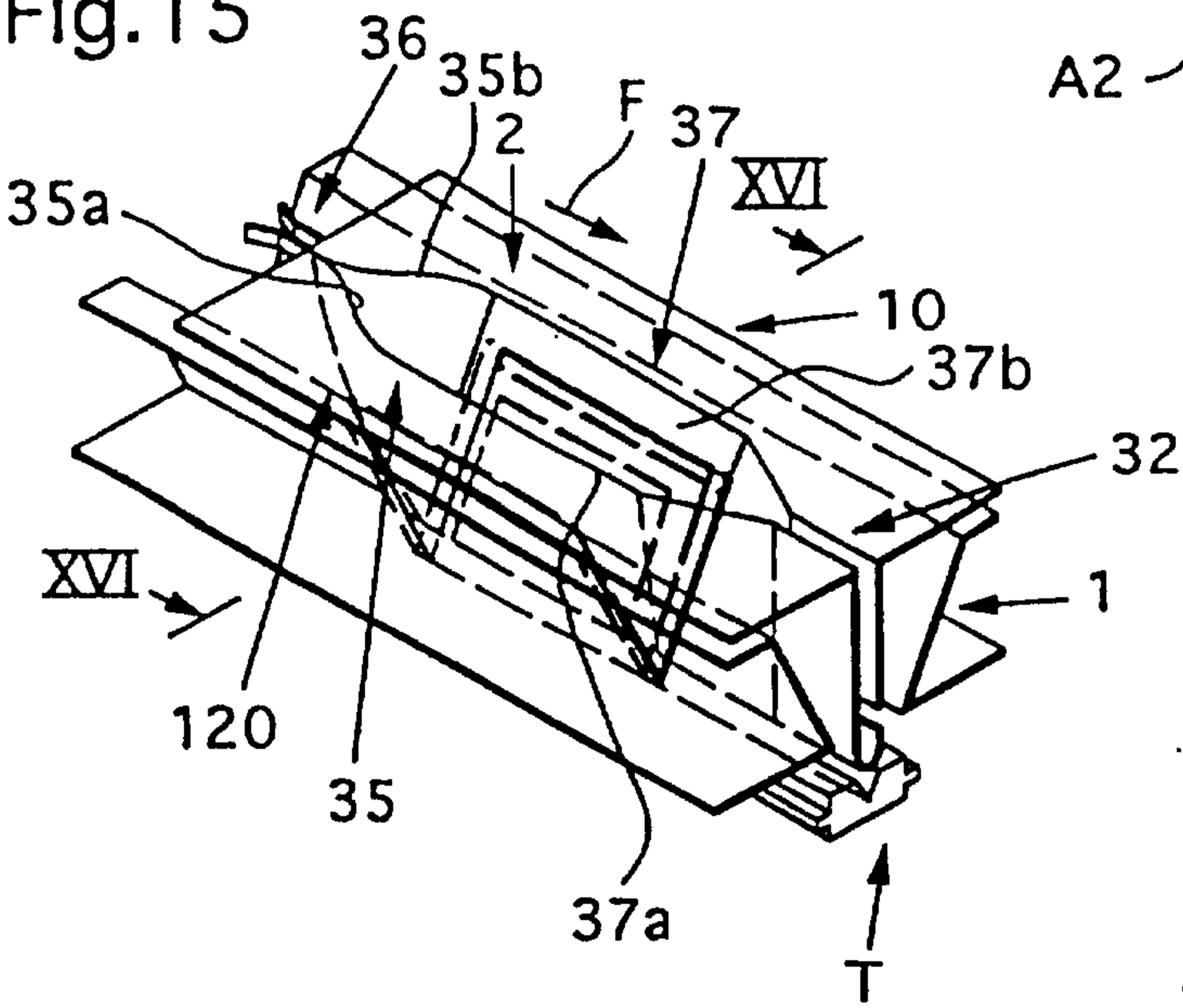

Fig.16

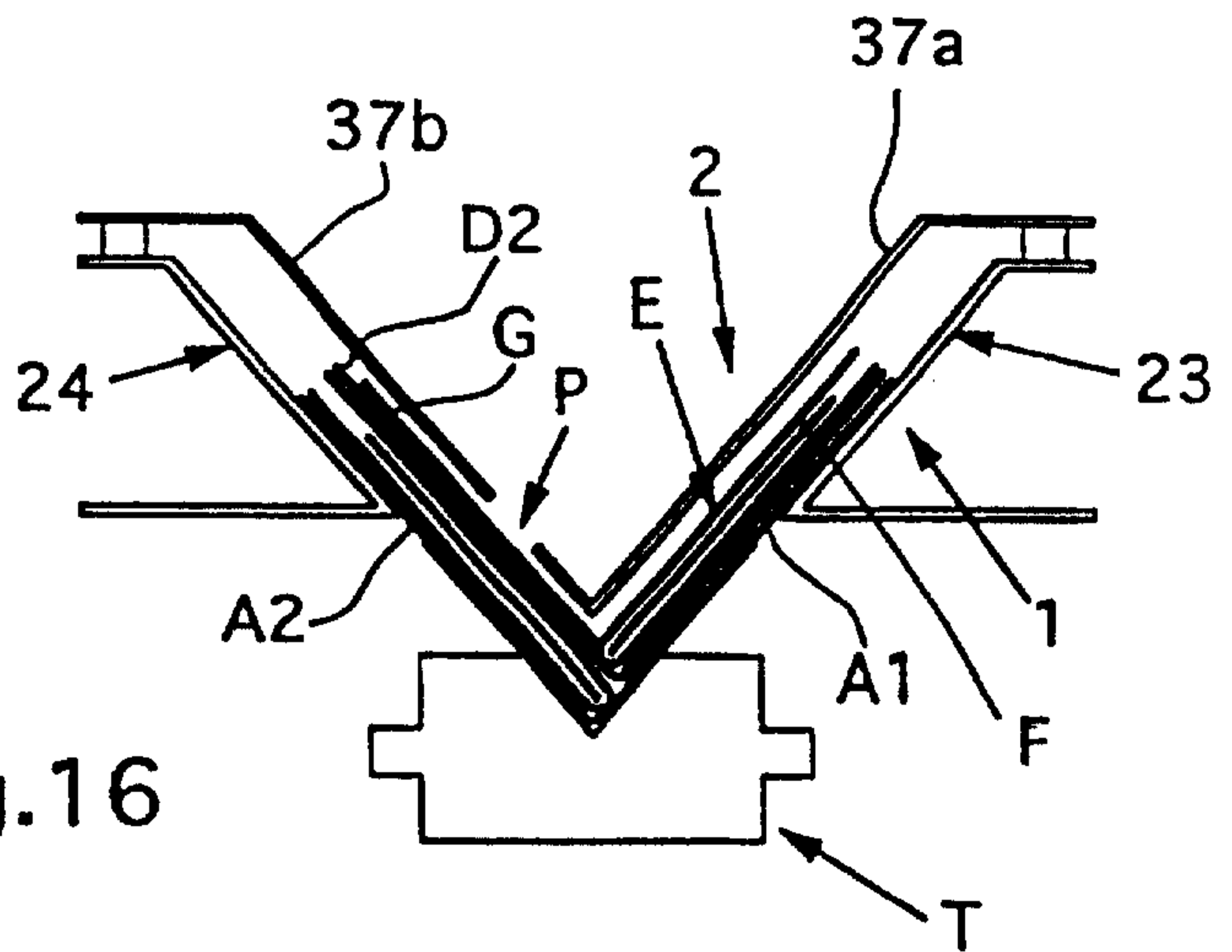

Fig.17

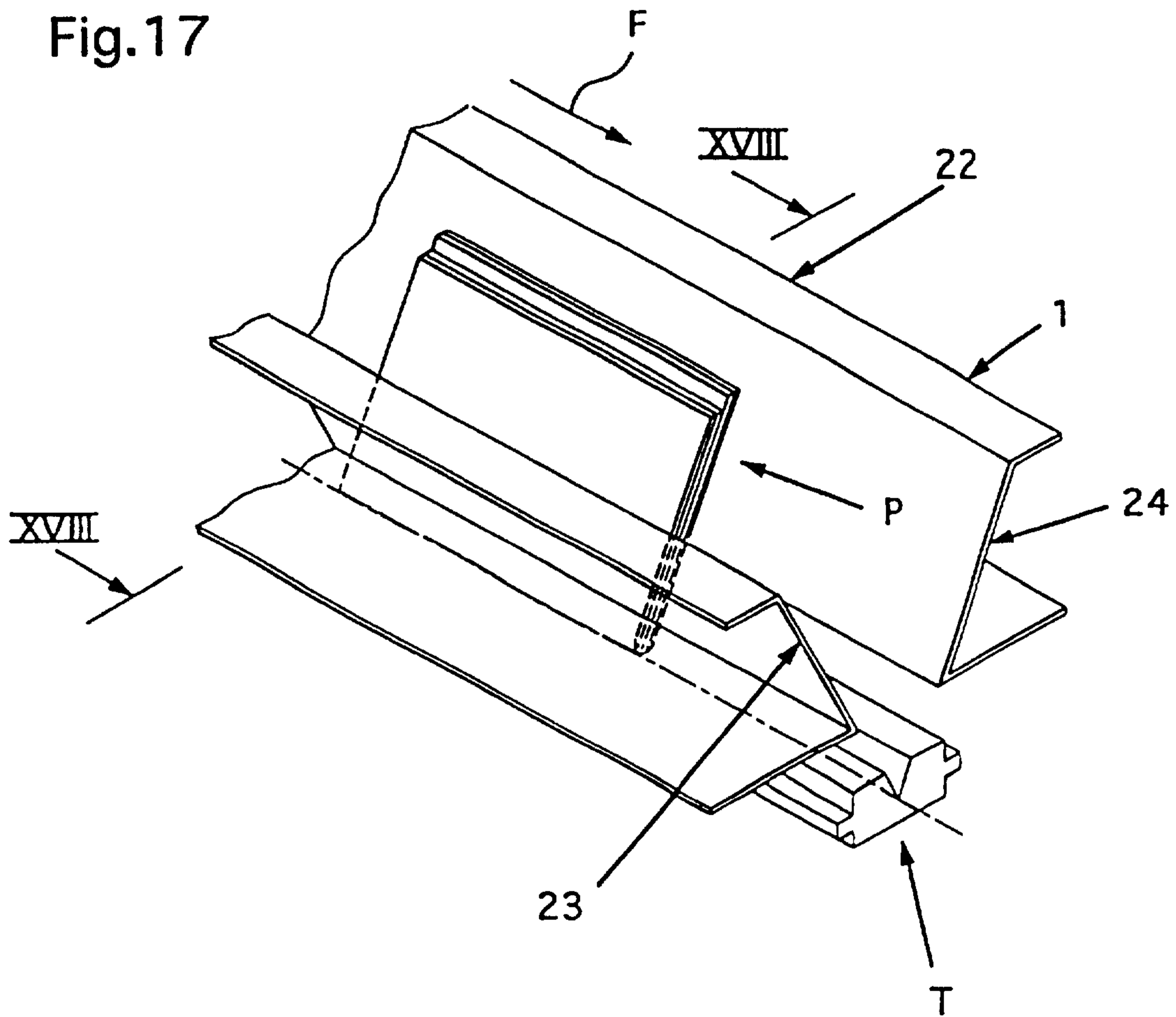

Fig.18

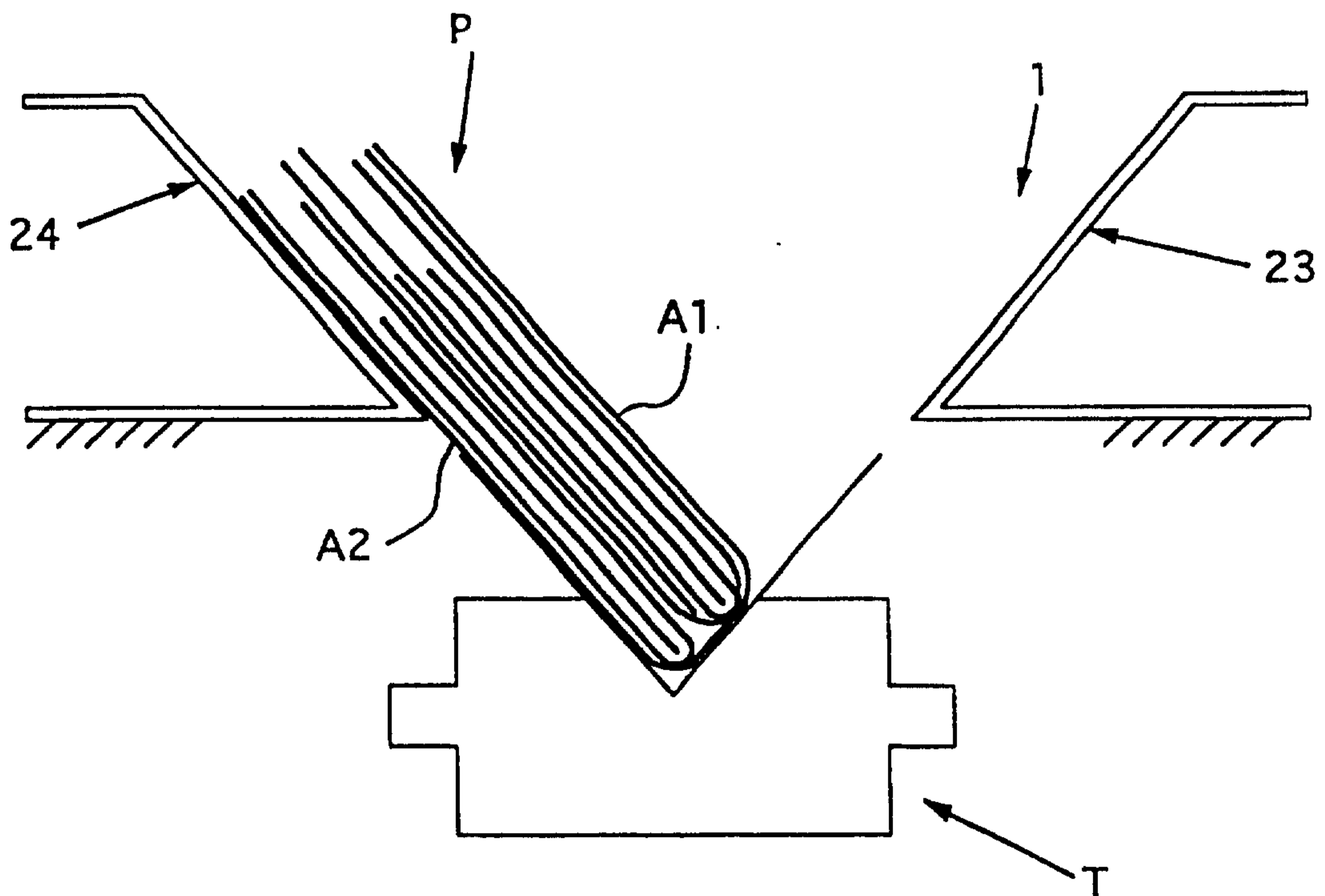

Fig.19

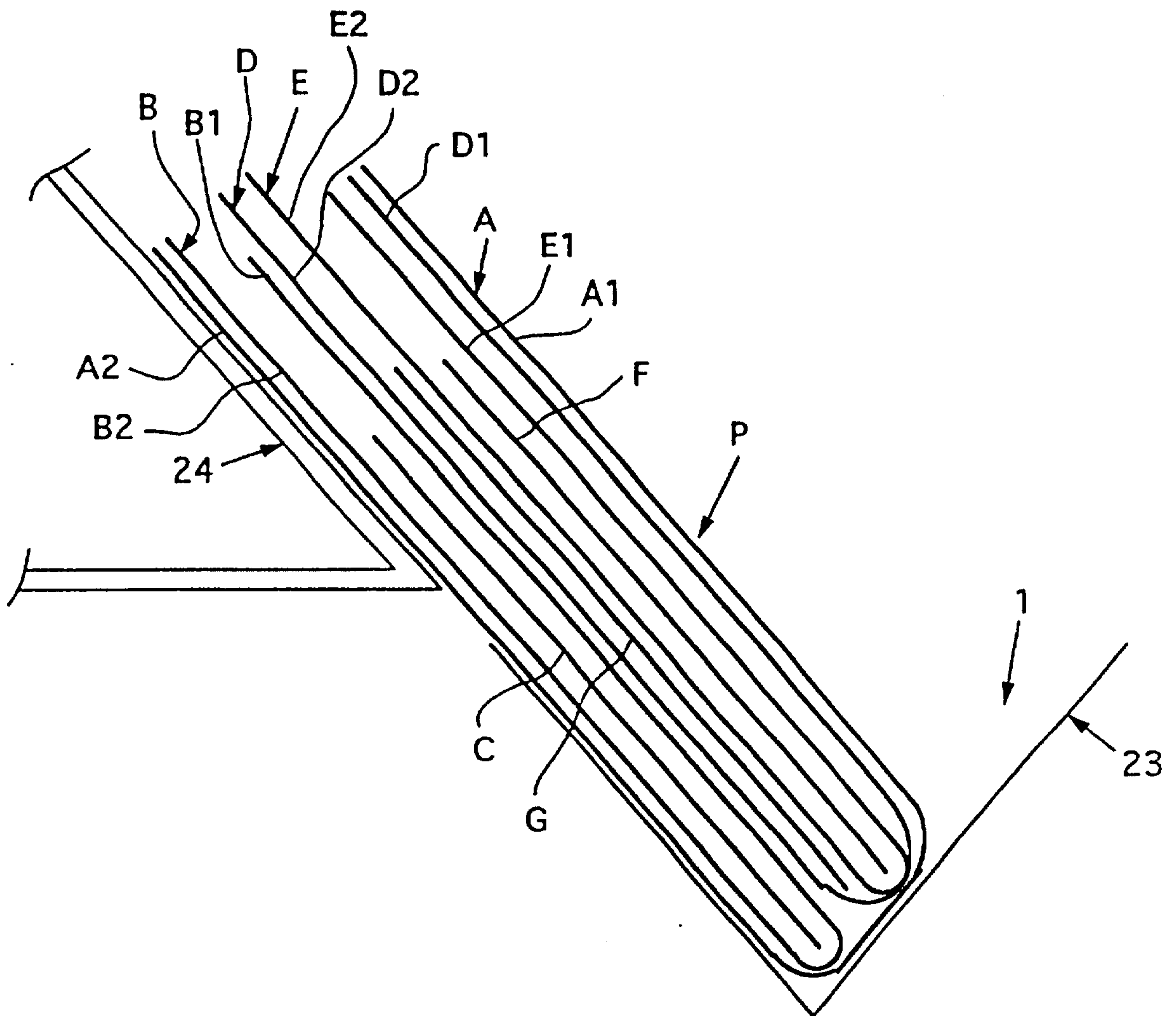

Fig.20

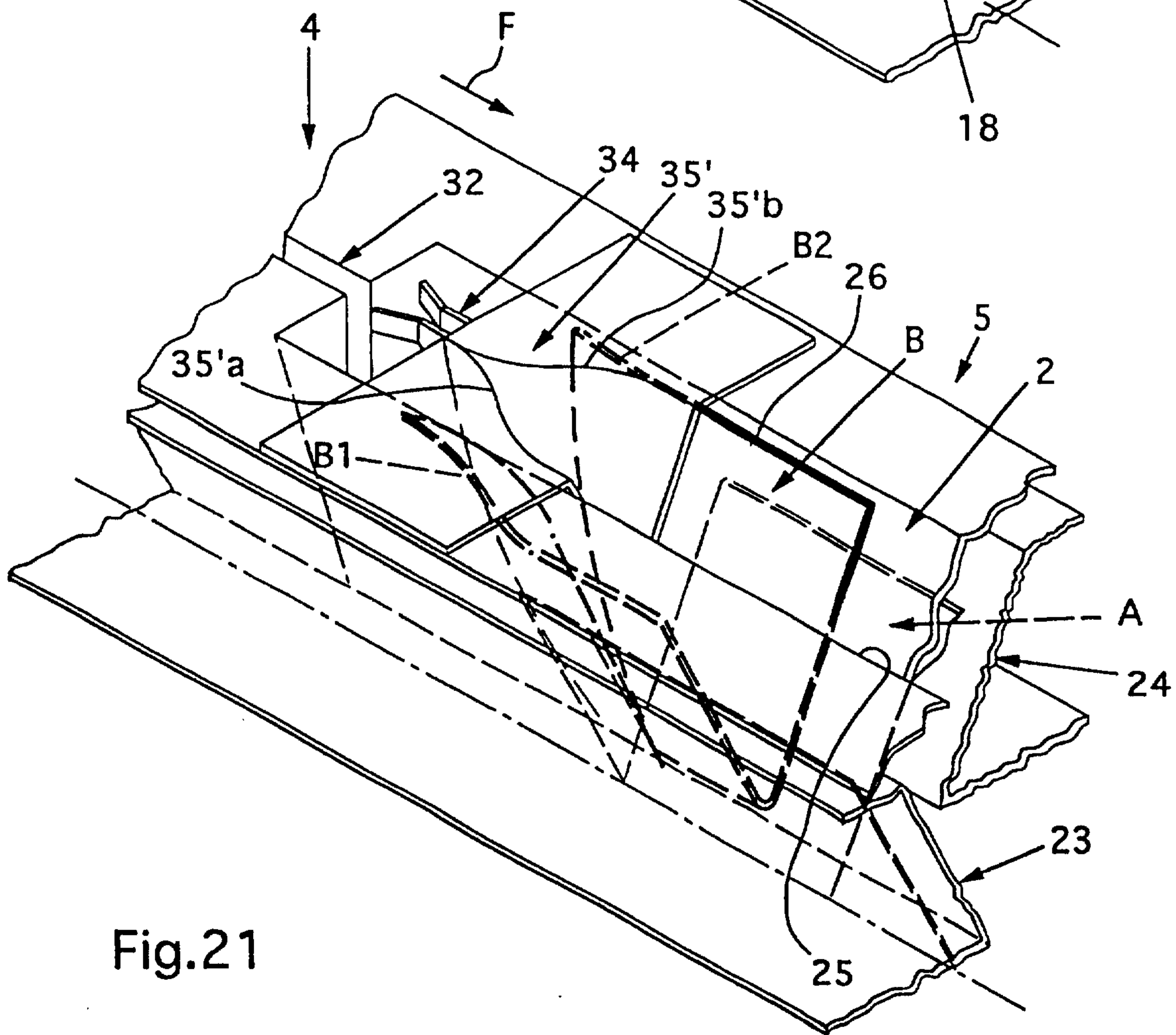
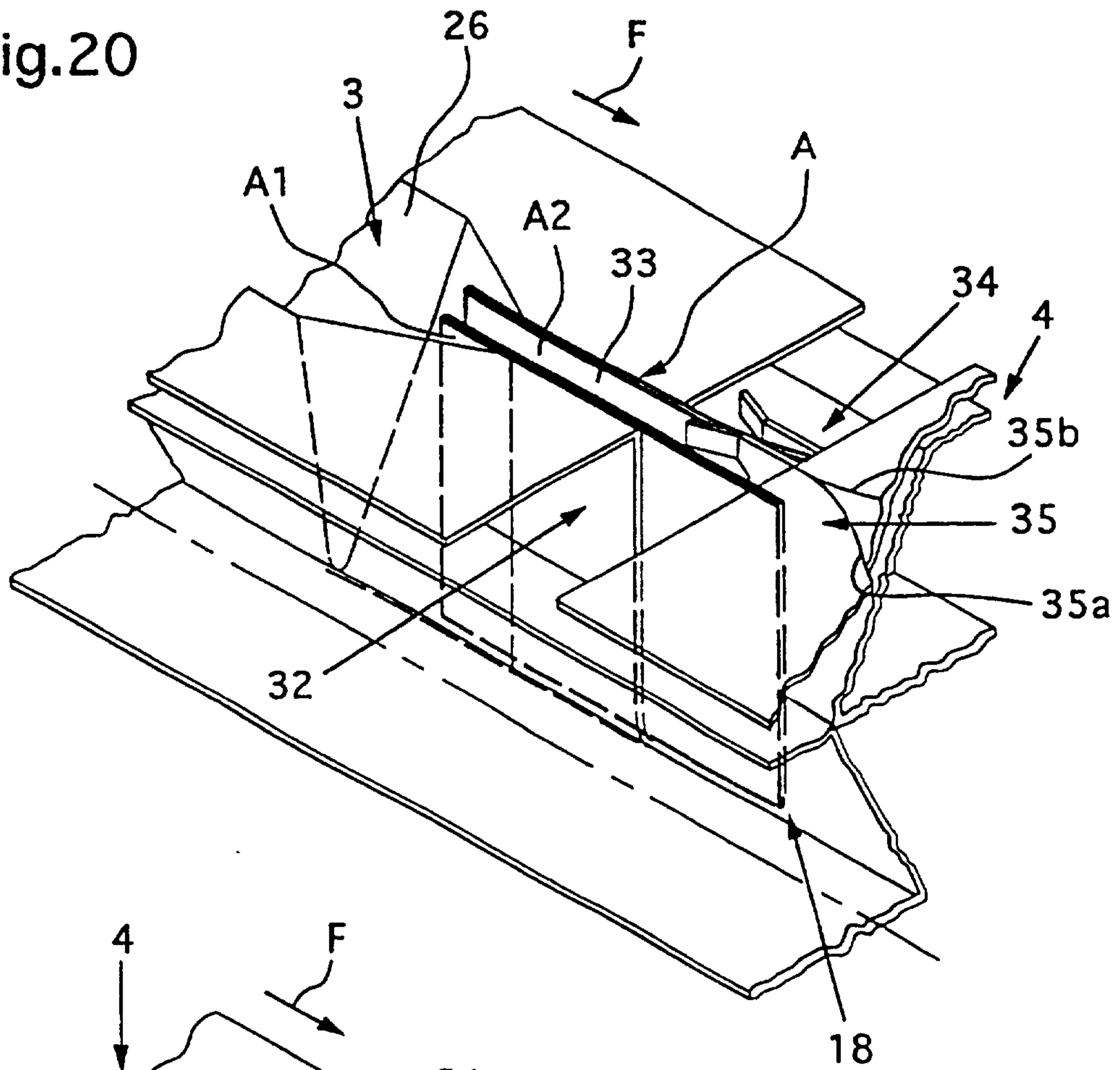

Fig.21

9/11

Fig.22

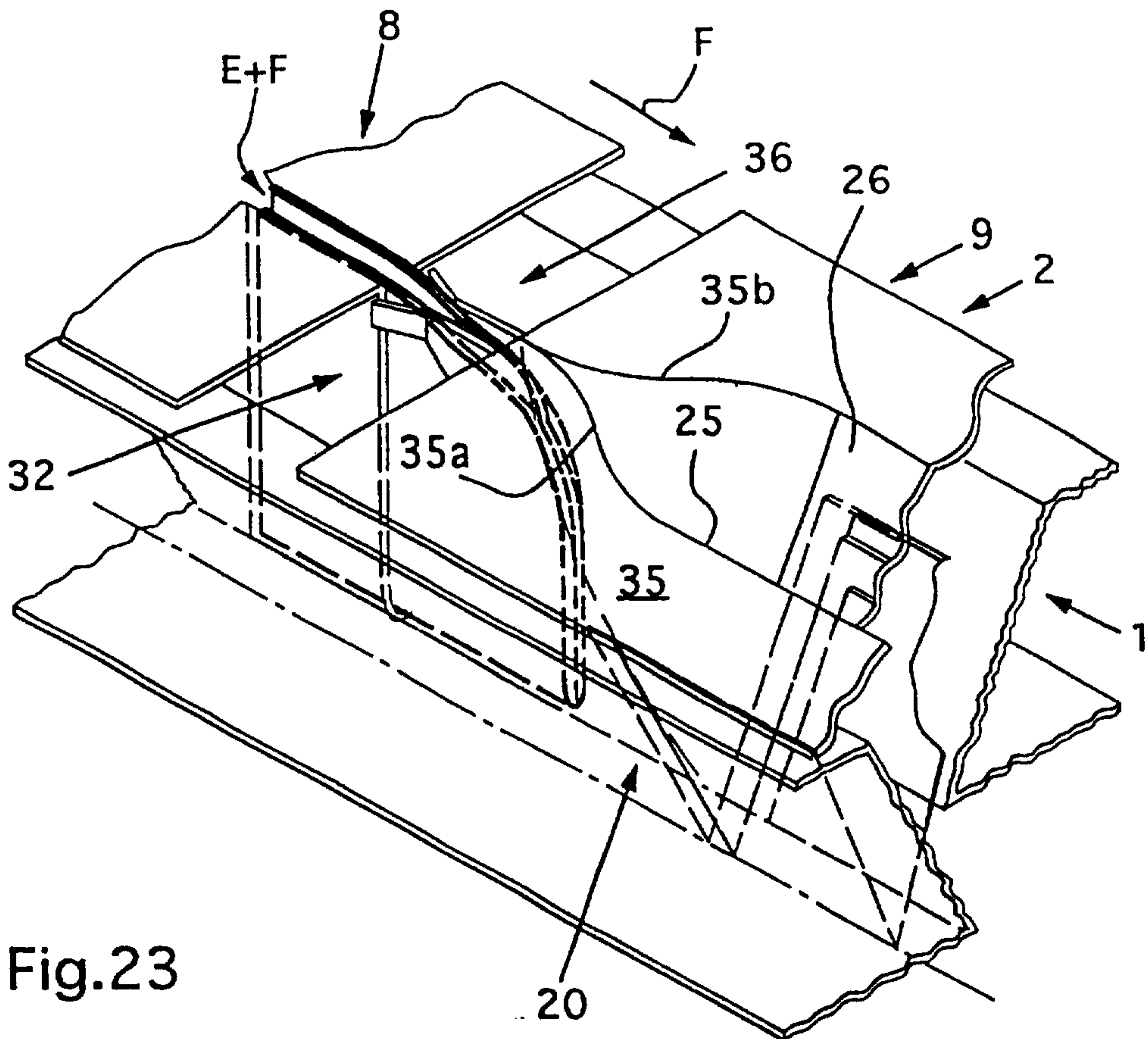
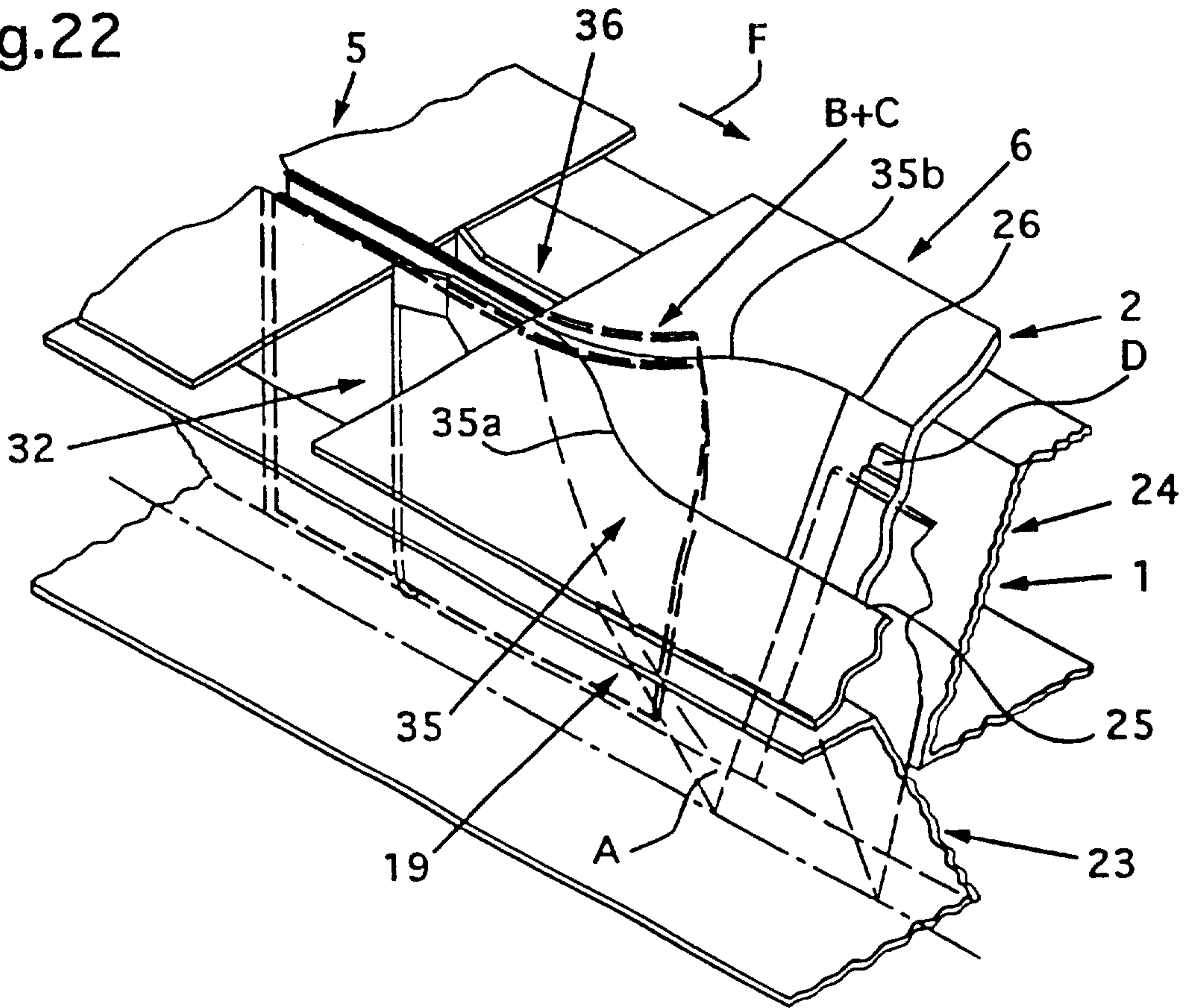

Fig.23

Fig. 24

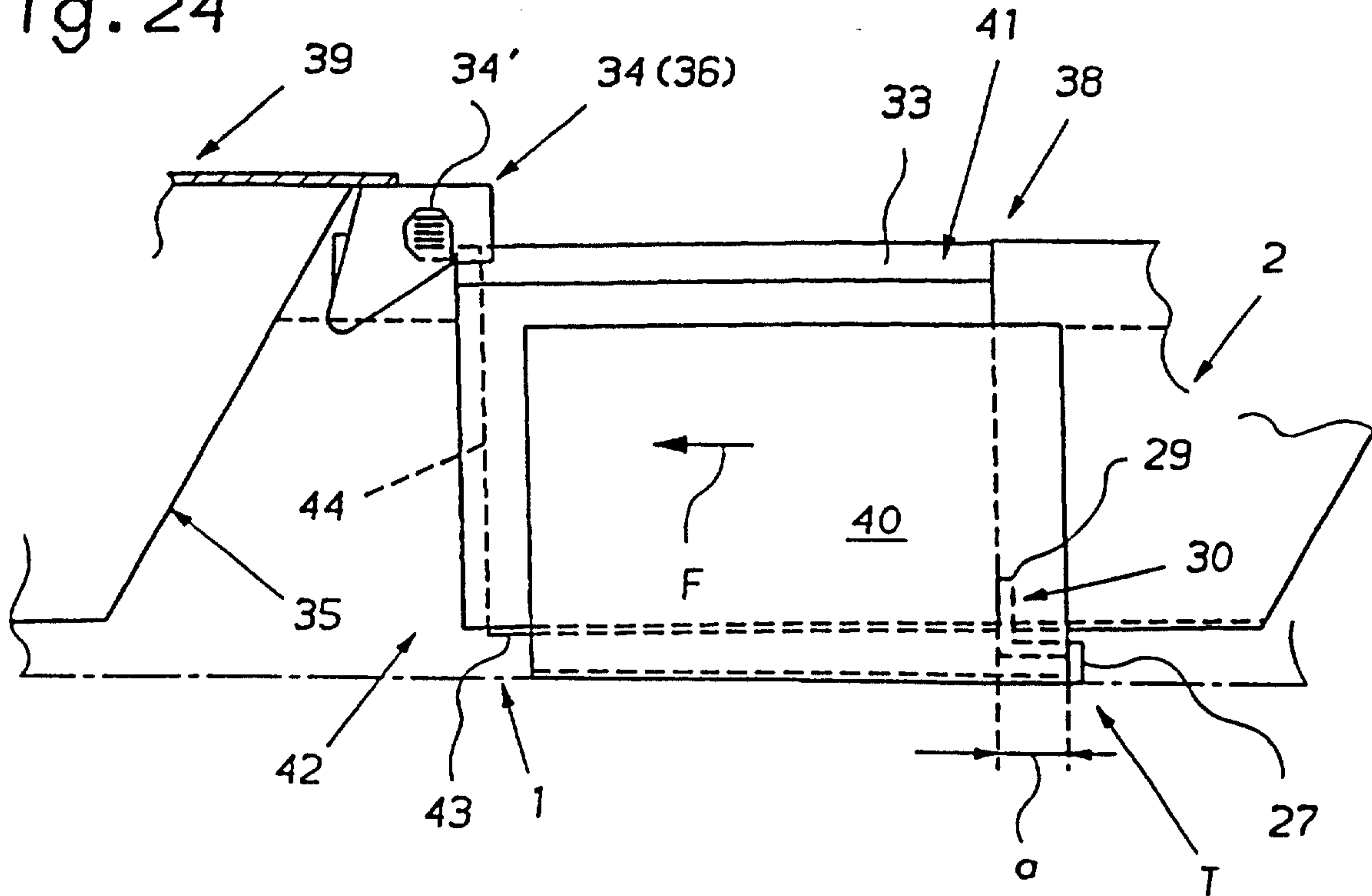

Fig. 25

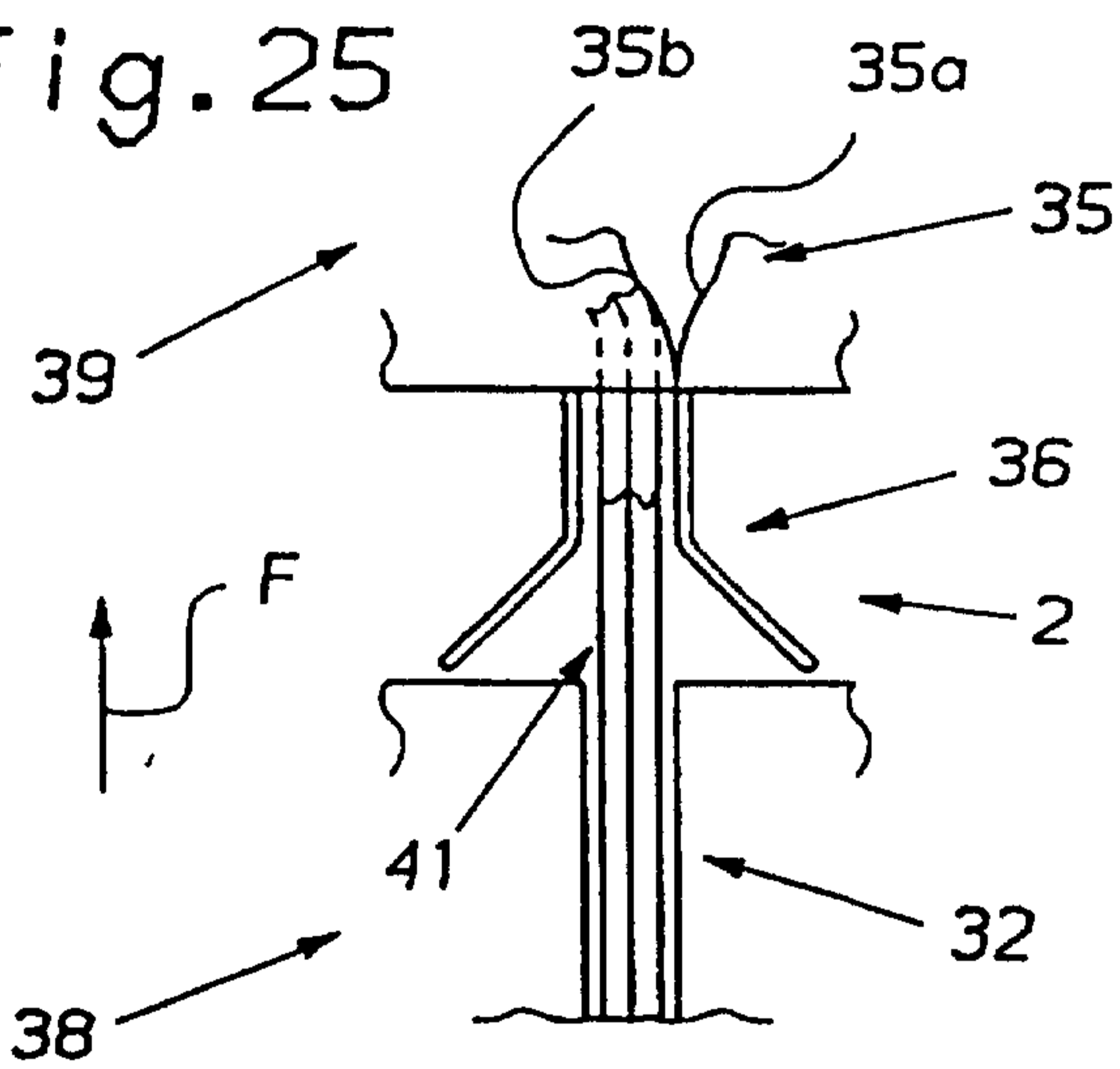

Fig. 26

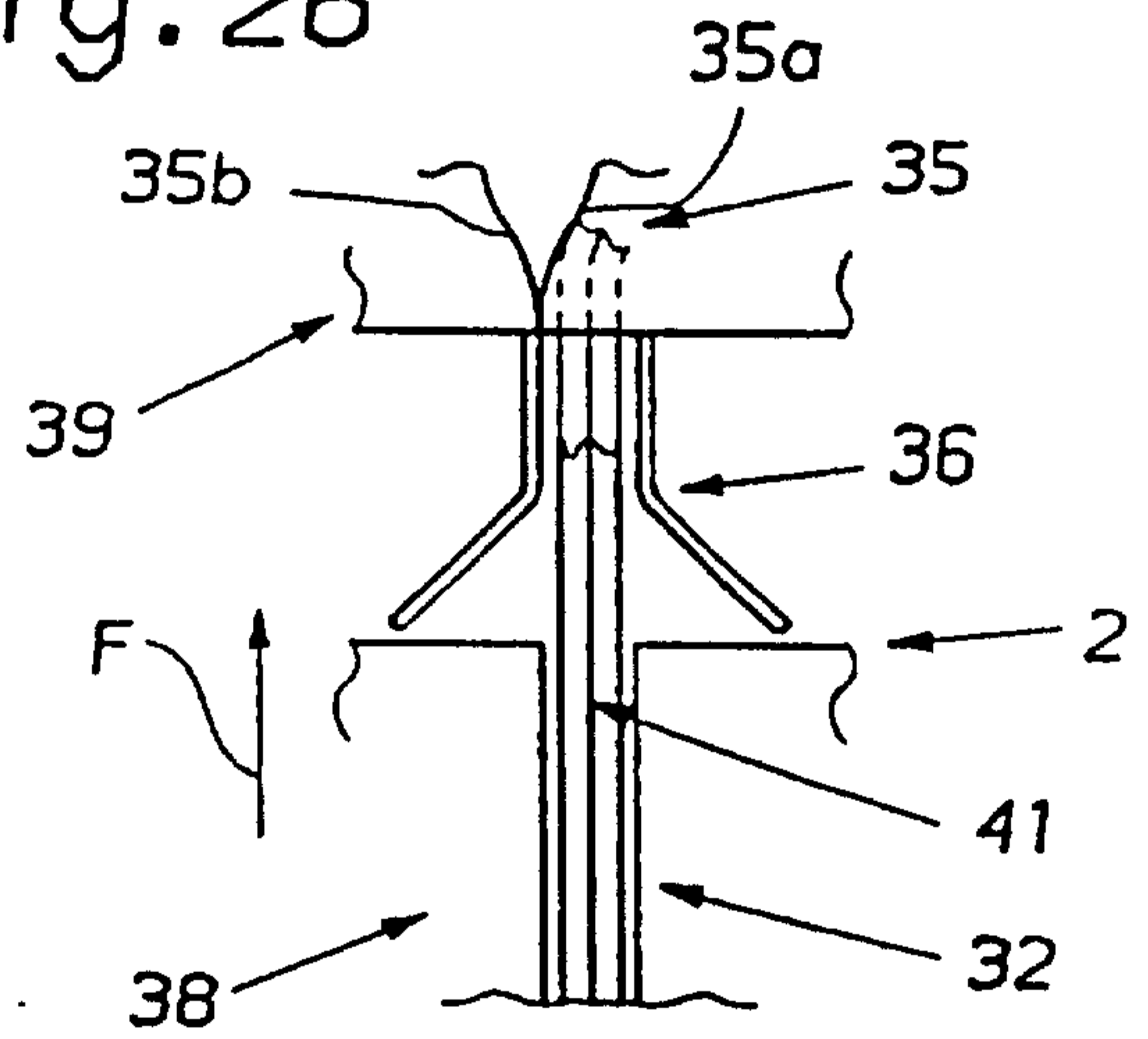

Fig. 27

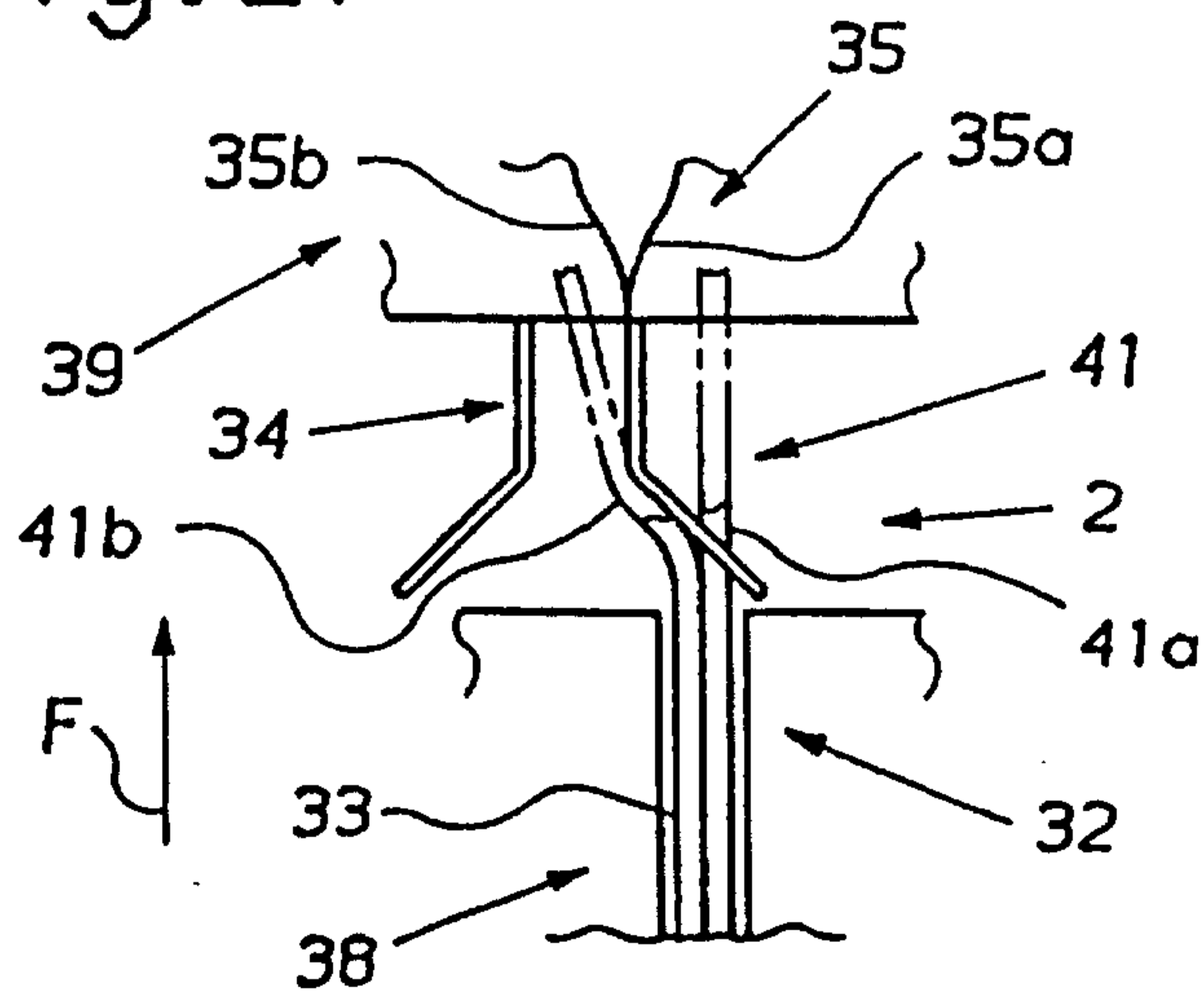

Fig. 28

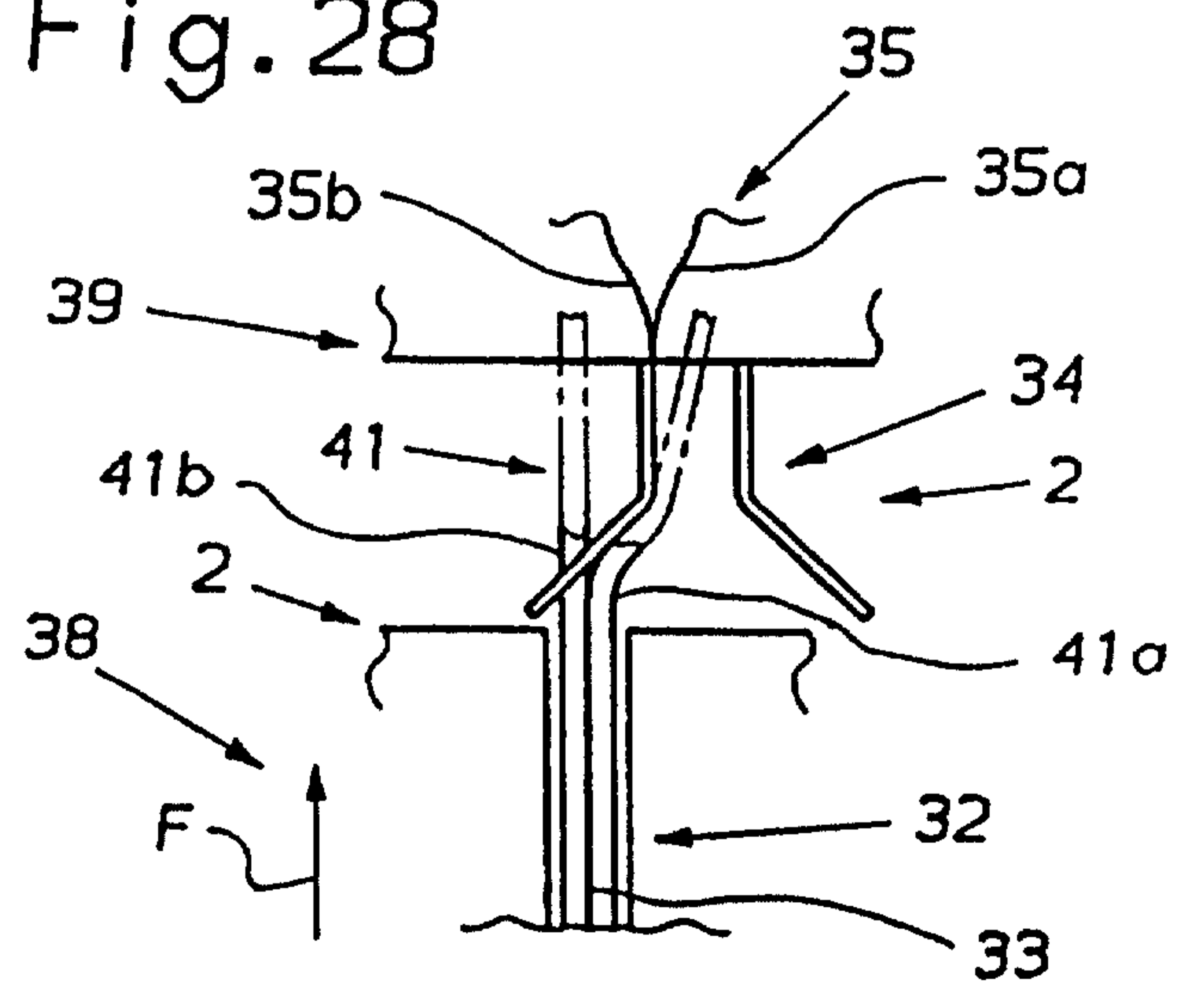

Fig.29

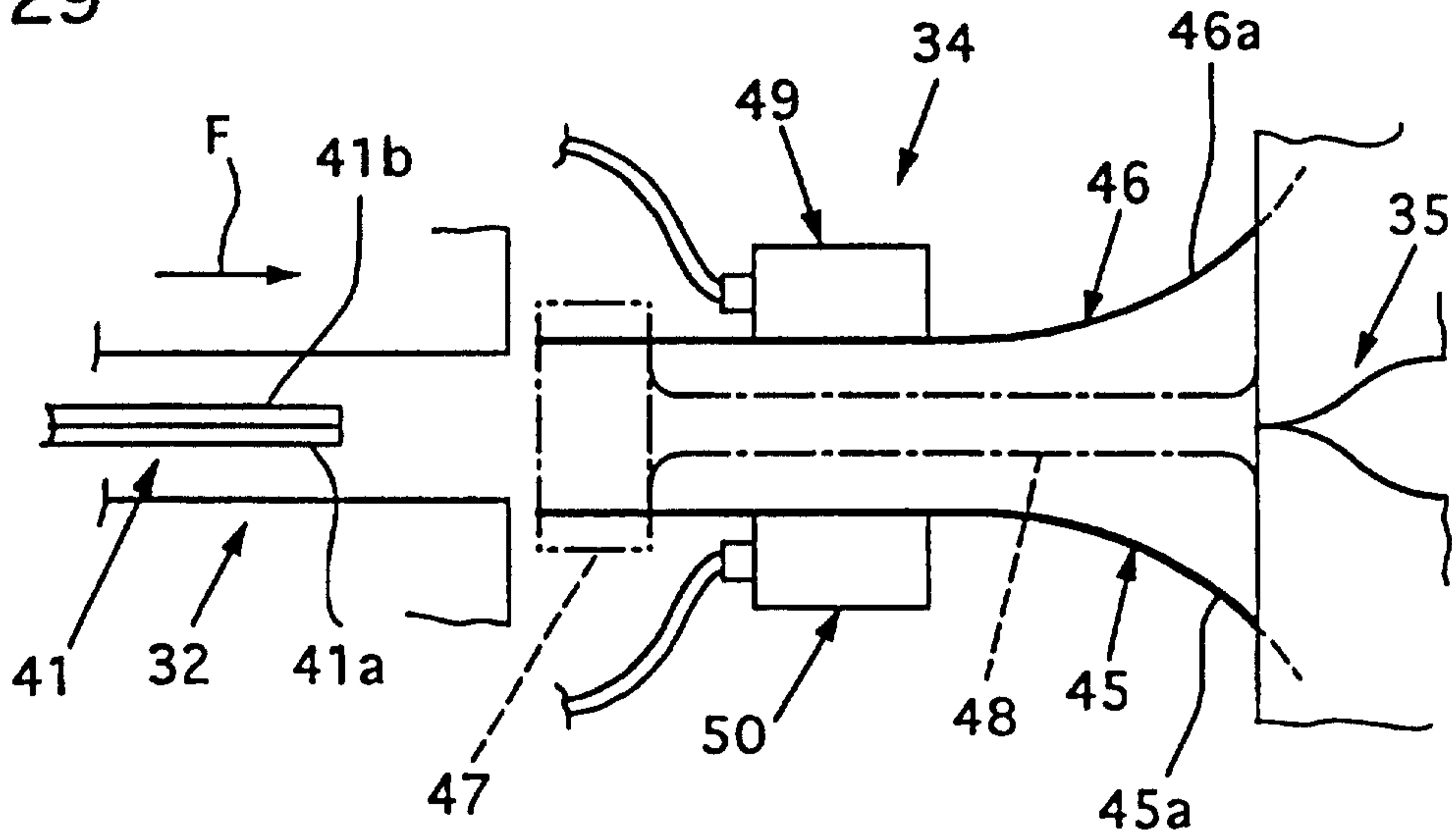

Fig.30

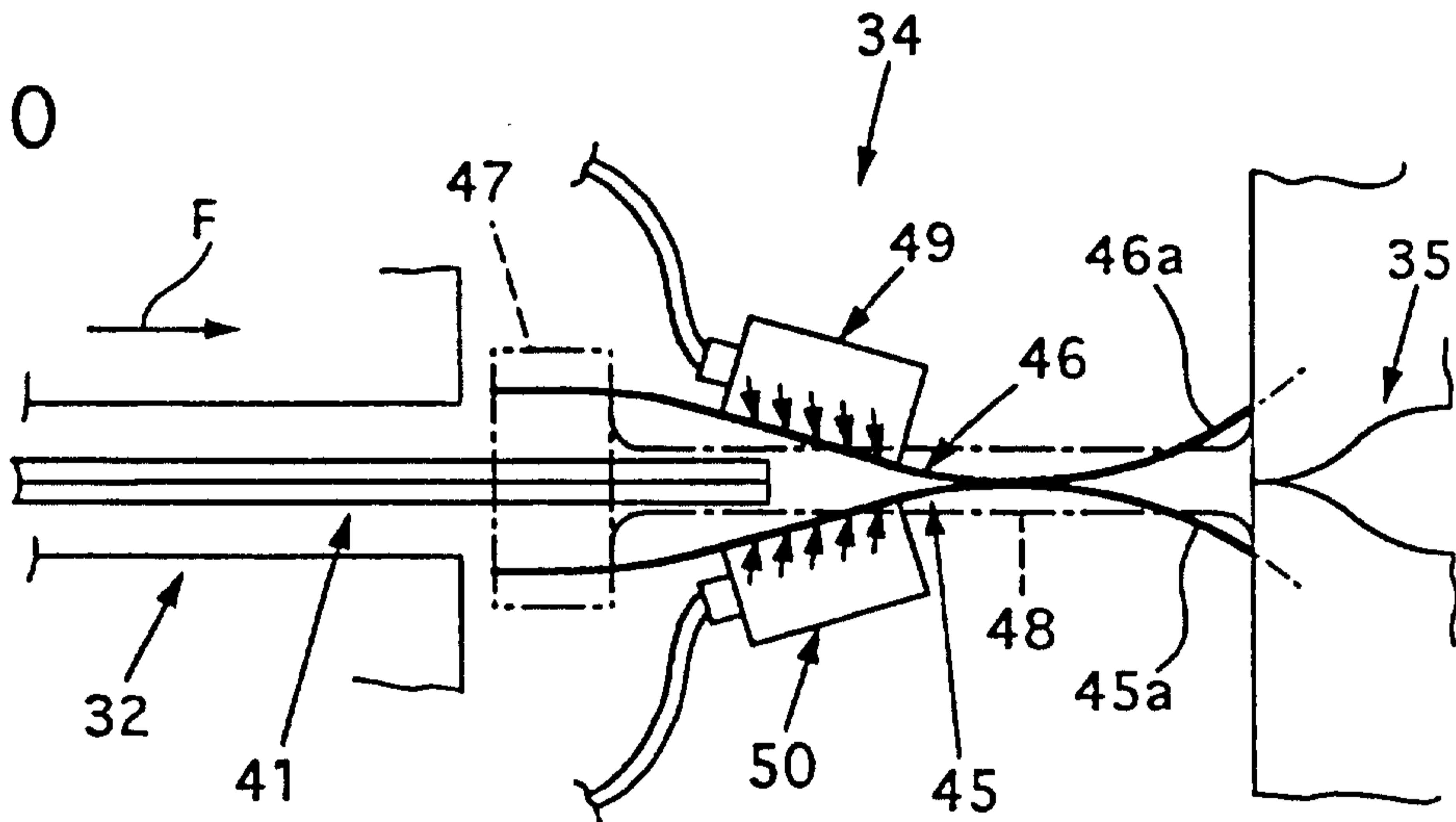

Fig.31

