

Nov. 17, 1953

B. FINEMAN ET AL

2,659,810

SEPARABLE GUARD FOR TROUBLE LAMPS

Filed Jan. 3, 1950

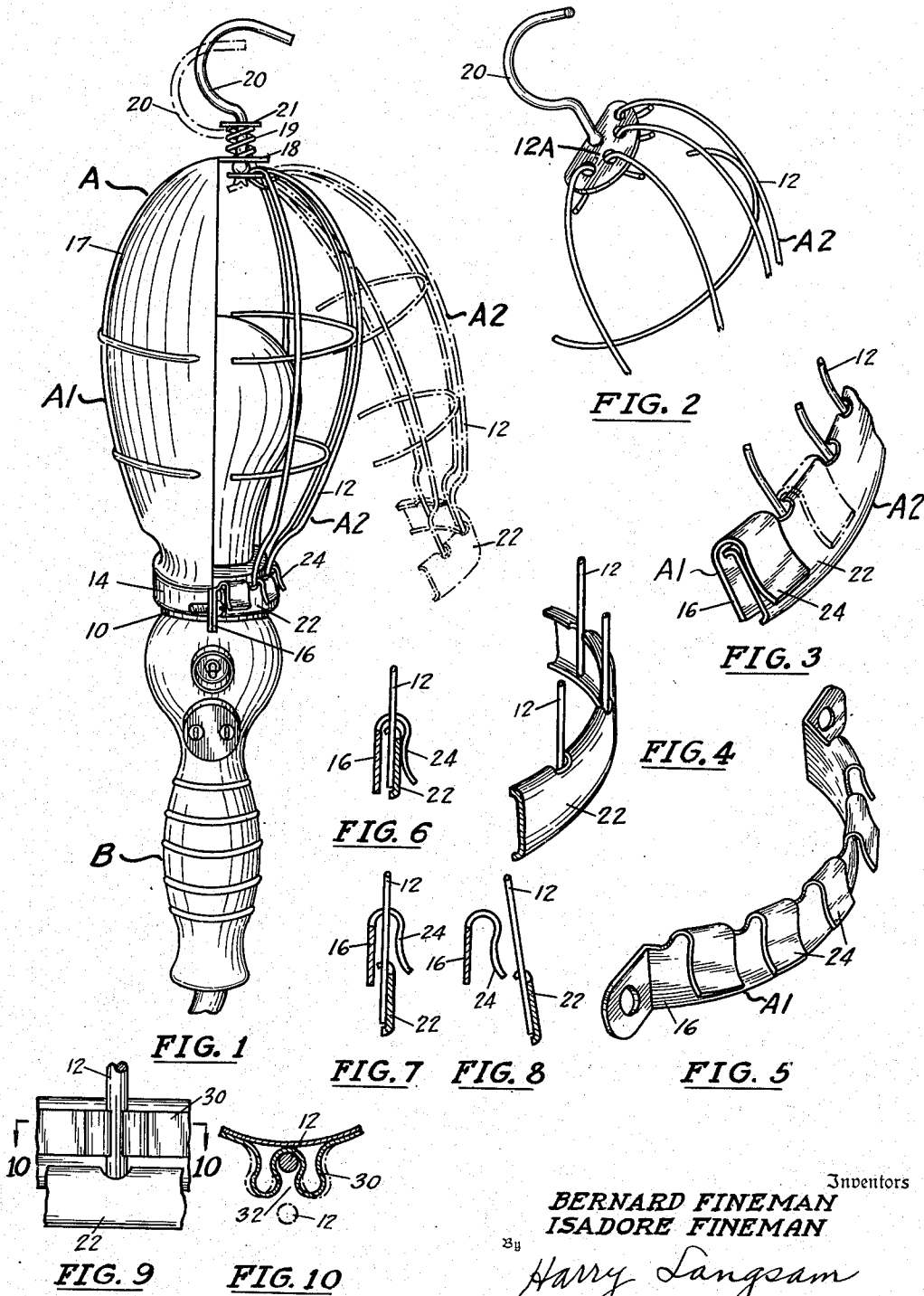

Inventors
BERNARD FINEMAN
ISADORE FINEMAN
By *Harry Langsam*
Attorney

UNITED STATES PATENT OFFICE

2,659,810

SEPARABLE GUARD FOR TROUBLE LAMPS

Bernard Fineman and Isadore Fineman,
Philadelphia, Pa.

Application January 3, 1950, Serial No. 136,526

1 Claim. (Cl. 240—54)

1

Our invention relates to a guard for an incandescent lamp and relates particularly to a guard for the lamp which may be easily separated to remove or replace the lamp and whereby the guard may be easily reassembled without the necessity of using any tools.

Heretofore, electric lamp guards have been used on trouble lamps which have a hand grip; the hand grip may have a switch and a convenience receptacle attached thereto. The lamp guards usually are made of two parts or sections wherein a hook for swingably attaching the lamp to a nail or a rod is employed; a semi-circular reflector also may be embodied in one section of the guard. However, the two parts usually are held together by a pair of bolts which require considerable time to remove and to insert the holding screws whereby the neck of the guard will be firmly affixed to the bulb-end of the handle.

It is an object of our invention to provide an electric lamp guard adapted to be affixed to socket handle which guard has a pivotally attached hook, whereby a reflector may be located in any position and wherein the guard may be easily opened to remove and to replace the electric lamp.

Another object of our invention is to provide a lamp guard which will grip a socket handle but may have a portion thereof removed without the use of any tools whatsoever.

Other objects of our invention are to provide an improved device of the character described, that is easily and economically produced, which is sturdy in construction, and which is highly efficient in operation.

With the above and related objects in view, our invention consists in the details of construction and combination of parts, as will be more fully understood from the following description, when read in conjunction with the accompanying drawing in which:

Fig. 1 is a side view of a socket handle or trouble lamp embodying our invention.

Fig. 2 is a fragmentary view of the detachable portions of the guard.

Fig. 3 is a fragmentary view of the details of the latching members.

Fig. 4 is a fragmentary view of the lower end detachable portion of the guard.

Fig. 5 is a perspective view of a portion of the latching member.

Figs. 6, 7, and 8 are fragmentary views of latching members in different positions.

2

Fig. 9 is a fragmentary view of a modification of our latching members.

Fig. 10 is a sectional view taken along the line 10—10 of Fig. 9.

Referring now in detail to the drawing wherein similar reference characters refer to similar parts, we show a combined lamp guard, generally designated as A, and a socket handle, generally designated as B, to hold an electric light bulb and which handle may be made of a soft rubber-like material and it may have a convenience outlet therein. The handle B has a suitable electrical socket therein and around the end wherein the bulb is located is a circumferential groove 10 which a lamp or bulb guard A is attached. The guard is primarily made of two separable sections A1 and A2 wherein wires 12 are suitably held together.

A two-piece collar 14, 16 is adapted to be held within the groove 10 on the handle and this collar always remains in position. The collar 14 is a part of the lamp guard section A1 which carries the reflector 17 and an extension 18 which has an opening therein through which a swivel hook 20 passes. A spring 19 is located between the extension 18 and a washer 21 which is firmly attached to the hook 20. This spring keeps the sections A1 and A2 taut. The hook 20 is adapted to slide within the opening of the top portion 13. The other end of the guard portion A2 has a semi-circular collar or rim 22 which is adapted to be locked within the collar 16. The collar 16 has a plurality of parallel spaced spring fingers 24 which are adapted to grasp the rim 22. The rim 22 and the hook 20 are firmly attached together by virtue of the wires 12 so that the hook and rim move in unison. The upper ends of the wires 12 (see Fig. 2) are hooked through a plate member 12A; and the end of the hook 20 is connected to swivel on the plate 12A. Hence, to replace a bulb the hook 20 is pushed downwardly as Fig. 1 is viewed and the rim 22 is pulled away from the collar 16 and the old bulb replaced and a new bulb inserted.

After the bulb has been changed the rim 22 is directed under the fingers 24 and the hook 20 is pulled upwardly to tighten the sections A1 and A2.

In Figs. 9 and 10 we show a modification of our invention wherein the wires 12 of the guard are adapted to engage a resilient series of properly spaced fingers 30. The resilient fingers 30 are formed on the collar and protrude outwardly from the collar; however, each finger is close enough to its adjacent finger to form a clasp so

3

that the wire 12 will be held therein. The wire 12 may be easily pulled from the fingers 30.

Although our invention has been described in considerable detail, such description is intended as being illustrative rather than limiting, since the invention may be variously embodied, and the scope of the invention is to be determined as claimed.

We claim as our invention:

A quick detachable guard for a trouble lamp comprising a pair of complementary substantially hemispherical members, one of said members being constructed to form a reflector means and the other of said members being a wire cage, the wires of which at one end, hook through openings formed in a substantially semi-circular ring portion and, at the other end, hook through openings formed in a plate member, said ring portion being resiliently connected to a semi-circular collar portion, and said plate member being adapted to underlie a lateral extension of said reflector member, a semi-circular collar portion complementary to said first collar portion on said reflector member, means to detachably connect said collar portions together, means to resiliently connect said plate member to said lateral extension, the resilient connection between said first mentioned semi-circular collar portion and said ring portion comprises a plurality of spring fingers formed on said collar portion and over-

4

lying said ring portion, said means to resiliently connect said plate member to said lateral extension comprises a hook having a straight stem thereon, said stem being adapted to extend through corresponding openings formed in said plate member and said lateral extension, means on said stem to space said plate member from said lateral extension and means on said stem abutting against that surface of said plate member which is remote from said spacing means to prevent withdrawal of said stem from said plate member, said stem having a washer affixed thereto and spaced from said lateral extension in a direction opposite to said plate member, and a spring mounted between said washer and said lateral extension, said spring being adapted to press said lateral extension toward said plate member and to draw said semi-circular collar into its complementary spring fingers.

BERNARD FINEMAN.
ISADORE FINEMAN.

References Cited in the file of this patent
UNITED STATES PATENTS

Number	Name	Date
972,480	Southwick	Oct. 11, 1910
1,334,710	Miners	Mar. 23, 1920
1,735,295	Olley	Nov. 12, 1929
2,178,907	Hockley	Nov. 7, 1939