

(19) World Intellectual Property Organization  
International Bureau



(43) International Publication Date  
26 September 2002 (26.09.2002)

PCT

(10) International Publication Number  
**WO 02/075938 A2**

- (51) International Patent Classification<sup>7</sup>: **H04B**
- (21) International Application Number: PCT/US02/08117
- (22) International Filing Date: 15 March 2002 (15.03.2002)
- (25) Filing Language: English
- (26) Publication Language: English
- (30) Priority Data:
 

60/276,398	16 March 2001 (16.03.2001)	US
60/296,229	6 June 2001 (06.06.2001)	US
60/301,529	28 June 2001 (28.06.2001)	US
09/942,372	29 August 2001 (29.08.2001)	US
10/004,989	3 December 2001 (03.12.2001)	US
- (71) Applicant: **AURA COMMUNICATIONS, INC.**  
[US/US]; 187 Ballardvale Street, Wilmington, MA 01877 (US).
- (72) Inventors: **PALERMO, Vincent**; 13 Stony Brook Road, Westford, MA 01886 (US). **MARSHALL, Charles, M.**; 667 South Bradford Street, North Andover, MA 01845 (US). **WHITE, Timothy, E.**; 35R Robbins Street, Acton, MA 01720 (US). **VOEGELIN, Stephen, A.**; 37 Joseph Way, Reading, MA 01867 (US). **LAFRANCHISE, Jeffrey, R.**; 27 Barton Street, Newburyport, MA 01950 (US).
- (74) Agents: **SMITH, James, M.** et al.; Hamilton, Brook, Smith & Reynolds, P.C., 530 Virginia Road, P.O. Box 9133, Concord, MA 01742-9133 (US).
- (81) Designated States (*national*): AE, AG, AL, AM, AT, AU, AZ, BA, BB, BG, BR, BY, BZ, CA, CH, CN, CO, CR, CU, CZ, DE, DK, DM, DZ, EC, EE, ES, FI, GB, GD, GE, GH, GM, HR, HU, ID, IL, IN, IS, JP, KE, KG, KP, KR, KZ, LC, LK, LR, LS, LT, LU, LV, MA, MD, MG, MK, MN, MW, MX, MZ, NO, NZ, OM, PH, PL, PT, RO, RU, SD, SE, SG,

[Continued on next page]

(54) Title: TECHNIQUES FOR INDUCTIVE COMMUNICATION SYSTEMS

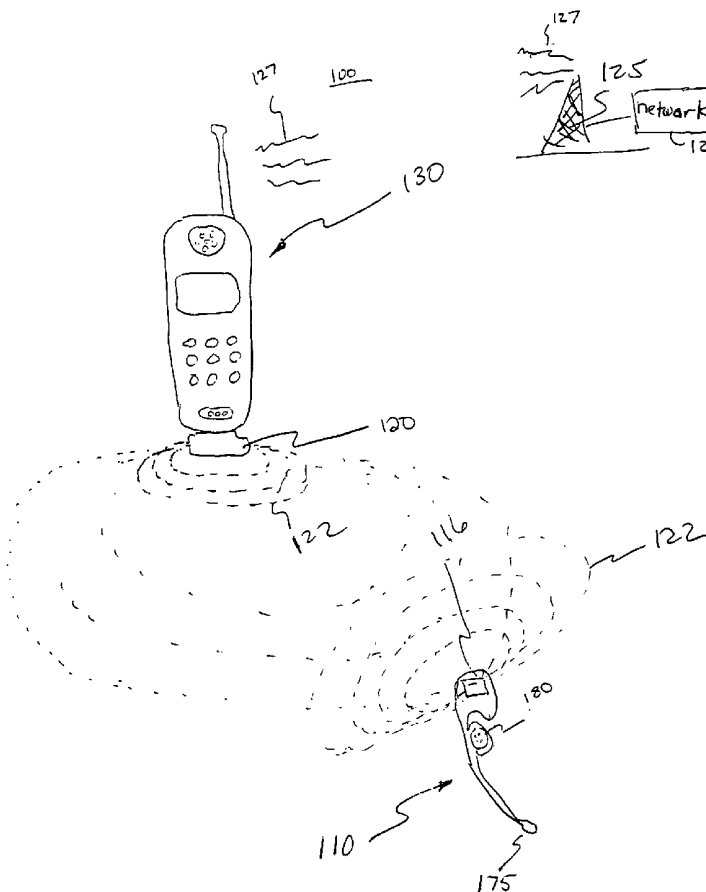

(57) Abstract: Contents of one or more received messages can be analyzed to determine whether a transceiver device generating the inductive field has already been programmed with a unique communication code. If not, bidirectional communications can be established to program the transceiver device with a unique communication code over an inductive link. Orientation or position of a transceiver device can be used to initiate a process for programming a communication code. Generally, the communication code can define a unique relationship between two or more transceiver devices.



WO 02/075938 A2



SI, SK, SL, TJ, TM, TN, TR, TT, TZ, UA, UG, UZ, VN,  
YU, ZA, ZM, ZW.

**(84) Designated States (regional):** ARIPO patent (GH, GM, KE, LS, MW, MZ, SD, SL, SZ, TZ, UG, ZM, ZW), Eurasian patent (AM, AZ, BY, KG, KZ, MD, RU, TJ, TM), European patent (AT, BE, CH, CY, DE, DK, ES, FI, FR, GB, GR, IE, IT, LU, MC, NL, PT, SE, TR), OAPI patent (BF, BJ, CF, CG, CI, CM, GA, GN, GQ, GW, ML, MR, NE, SN, TD, TG).

**Published:**

— *without international search report and to be republished upon receipt of that report*

*For two-letter codes and other abbreviations, refer to the "Guidance Notes on Codes and Abbreviations" appearing at the beginning of each regular issue of the PCT Gazette.*

## TECHNIQUES FOR INDUCTIVE COMMUNICATION SYSTEMS

### BACKGROUND OF THE INVENTION

Transducers have been incorporated in transceivers to transmit and receive inductive fields. In a typical application, each of two transceiver devices supporting  
5 bi-directional communication includes two specifically tuned transducers, one of which is tuned for transmitting while the other is tuned for receiving.

Interference can occur among transceiver devices when a common carrier frequency is used by the transceivers to simultaneously transmit data information. In this instance, it is likely that an additional transceiver device within communication  
10 range can “eavesdrop” and receive information originally intended for another transceiver. This can be annoying or even detrimental if the communication was intended to be confidential.

Unlike RF (Radio Frequency) antennas, inductive transducers couple to each other via magnetic flux. Thus, unique problems arise when multiple transceiver  
15 devices attempt to share an available bandwidth to communicate with each other.

### SUMMARY OF THE INVENTION

The present invention is directed towards an inductive communication system in which messages are received at a transceiver device over an inductive field.

20 Contents of one or more received messages can be analyzed to determine whether a transceiver device generating the inductive field has already been programmed with a unique communication code. If not, bidirectional communications can be established to program the transceiver device with a unique communication code over an inductive link. Typically, the communication code is a  
25 sequence of bits identifying a relationship between two or more transceivers for exclusive communications.

A communication code can be a unique identifier that is transmitted in messages between transceivers so that the recipient can identify a source of the message. If a received message includes an unexpected or unknown communication code, the message can be ignored.

5 An activation protocol such as orientation or position of a transceiver can cause one or multiple transceivers to be initialized with a communication code. For example, to initialize a pair of transceivers with a code, the transceiver devices can be moved in close proximity to each other. Proximity of a transceiver can be detected by sensing the strength of a received signal or orientation of an inductive  
10 field.

Following detection of a predetermined activating condition, a communication code can be generated and assigned for future use by the transceivers. As mentioned, the transceivers can maintain an exclusive communication relationship based on use of the communication code.

15 In one application, a button is pressed indicating that a transceiver device is to be initialized with a code. If a predetermined sequence of events such as proper orientation or proximity of the transceiver device is detected within a time window, an initialization process to program a code is initiated.

Another method to initiate the initialization process of establishing a  
20 communication code includes detecting a paging message. For example, a paging message received from a transceiver device can indicate a desire by a user to establish a communication code. A paging message can also indicate a desire by a user to establish an exclusive communication link using the programmed code.

A paging message can include a data field including the communication code  
25 so that a transceiver receiving the message can determine whether communications have been established with the transceiver device in the past. If the communication code received at a transceiver is a value unbeknownst to a monitoring transceiver device, a new communication code for communicating can be established. On the other hand, if the paging message includes a code recognized by the receiving  
30 transceiver device, a communication link can be established based on the code.

Using the communication code, a transceiver can determine the type of transceiver device and its functionality. For example, the code can identify whether a newly linking transceiver device is a mouse or a keyboard device.

As discussed, the initialization process to establish a code can be initiated at least in part by sensing a predetermined condition caused by a user. For example, a user can press a button on a transceiver device to activate an initialization process. Also, the user can move a transceiver device closer in proximity than is required for normal communications to initiate the initialization process. In general, a proximity of a transceiver device can be sensed based on the strength of a received signal. If the received signal is above a threshold value, it can be determined that the transceiver device is so close in proximity that such a condition is an indication that a user desires to program a transceiver with communication code.

An orientation of the transceiver device can be detected based on an axis of a received inductive field to determine whether a user desires to initiate programming of a communication code. Proximity of a transceiver device as well as orientation can be monitored to determine that a transceiver device should be initialized.

After programming, a communication code can be stored to support future exclusive communications. More specifically, a base transceiver and remote transceiver can both store a communication code in non-volatile memory. A transceiver can store different communication codes for each of multiple transceiver devices with which it can communicate.

When creating a new link, each device can determine based on use of a communication code whether the devices have communicated with each other in the past. If so, the initialization process of programming a communication code can be skipped and the transceivers can communicate almost immediately using a code.

A communication code can be derived at least in part based on a randomly generated number. Thus, two different random transceivers are unlikely to be programmed with the same code. In a multi-point communication system, all or a portion of bits in the communication code can be common to multiple transceiver, thereby enabling multiple transceivers to communicate using a single, shared

communication code. Use of such a code can be advantageous when a transceiver broadcasts to multiple transceivers simultaneously.

As discussed, a portion of the code can identify a type of communication device to which the transceiver is coupled. In this way, a communication code is  
5 unique yet it also includes information identifying a type of transceiver. A format of data to be transmitted between devices can be determined based on a code.

In one instance, a base transceiver device is used in a cellular phone and a remote transceiver device is used in to a headset including a speaker and a microphone. Based on use of a communication code and bidirectional  
10 communications between the transceiver devices, a user can communicate over an exclusive inductive link between the cell phone and headset. A user wearing the headset can therefore communicate with a remote party through a phone link supported by the cell phone. The transceiver devices can include multiple transducers so that continuous communication between the headset and cell phone  
15 can be maintained regardless of the orientation and position of the transceiver devices.

Another aspect of the present invention is directed towards a system and method supporting inductive communications among multiple transceivers in a multi-point communication system. In an illustrative embodiment, bidirectional  
20 communications are supported between pairs of transceivers selected from at least three transceivers. Each pair of communicating transceivers can be assigned one or more time slots in which to communicate. At least one transceiver can include multiple transducer elements that are selectively activated to support communications between the transceivers regardless of their orientation relative to  
25 each other. A transceiver can be incorporated in many types of devices including computer equipment, games, mobile phones, Personal Digital Assistants (PDA), or headsets.

A comparator can be used to compare link qualities of communications of different transmit-receive transducer elements of the pairs of transceivers  
30 communicating with each other. Based on detected link quality, a controller can select which of multiple potential transmit-receive transducer elements of a

transceiver pair will be used to support further communications. Consequently, multiple transceivers can communicate with each other over selected transducer elements.

In one application, at least one pair of transceivers includes multiple  
5 transducers to support communication at any angular orientation. For example, a first transceiver including three orthogonal transducers can communicate with a second transceiver including at least one transducer. Each combination of transmit-  
receive pairs of transducers between the transceivers can be compared to determine which provides an acceptable link quality. As mentioned, a controller can select  
10 which set of transducers between a pair of transceivers is used to support future communications based on detected link quality. A set of transceivers can include a transducer in each transceiver, multiple transducers in one transceiver and a single transducer in another transceiver, or multiple transducers in each transceiver.

During operation, a signal can be transmitted from one transceiver to  
15 multiple transceivers. Each of multiple transceivers can simultaneously receive the transmitted signal to determine link quality for a potential future link between transceivers. Since multiple transceivers detect link quality simultaneously, less bandwidth is necessary to determine signal quality of multiple links than when the process is performed individually for each transceiver at different times.

20 Link qualities can be determined by comparing which of multiple transducer elements in a transceiver device produces a strongest signal in a receiving transceiver. A message can be sent from the receiving transceiver indicating which of multiple transducer elements in a transmitting device produces a strongest signal. Typically, the strongest signal is determined based on which transducer element  
25 receives the largest amplitude of a received signal such as a voltage signal corresponding to strength of a received inductive field. Link qualities can also be determined by comparing which of multiple transducer elements in a receiving device produces a strongest signal from a transmitting transceiver.

In one application, link quality can be determined by identifying how many  
30 bits in transmitted signal are properly received at a transceiver.

A set of multiple transceivers in a communication system can include a base transceiver and at least two remote transceivers with which the base transceiver communicates. The base transceiver can include multiple orthogonal transducers and each of the remote transceivers can include as few as a single transducer. Based  
5 on this topology, each transceiver can be positioned at any angular orientation relative to the others, yet communication can be continuously maintained via a selected pair of transmit-receive transducers in each base-remote transceiver pair. Communications also can be supported by activating more than two transducers to transmit or receive an inductive field.

10 Each of multiple remote transceivers communicating with a base transceiver can include multiple orthogonal transducer elements, while the base transceiver includes one transducer element. One of the multiple transducers in a remote transceiver can be selected to transmit and receive messages from the base transceiver including only one transducer.

15 As previously discussed, wireless bandwidth can be shared among the multiple transceivers without interfering with each other using time slots and, optionally, communication codes. At least a portion of the wireless bandwidth can be allocated for receiving paging signals from other transceiver devices trying to establish a communication link. Consequently, paging transceivers can share a  
20 wireless bandwidth with other transceivers already communicating with each other.

As mentioned, a group of transceivers communicating with each other can utilize communication codes to support exclusive communications. A new transceiver not yet initialized with a communication code can initiate a programming routine in which a communication code is assigned for communications. To  
25 establish a new communication code or relationship between transceiver devices, a transceiver can send paging signals to a base transceiver that, in response to an activation sequence, generates a unique communication code for bidirectional communications. Typically, a communication code is transmitted in each message so that a receiving transceiver can identify that the message is generated from a  
30 particular device.

## BRIEF DESCRIPTION OF THE DRAWINGS

The foregoing and other objects, features and advantages of the invention will be apparent from the following more particular description of preferred embodiments of the invention, as illustrated in the accompanying drawings in which  
5 like reference characters refer to the same parts throughout the different views. The drawings are not necessarily to scale, emphasis instead being placed upon illustrating the principles of the invention.

Fig. 1 is a pictorial diagram of a wireless communication system according to certain principles of the present invention.

10 Fig. 2 is a block diagram of transceiver devices and corresponding circuit components according to certain principles of the present invention.

Fig. 3 is a block diagram of a hub topology in which a base transceiver communicates with multiple remote transceiver devices according to certain principles of the present invention.

15 Fig. 4 is a timing diagram illustrating a bandwidth partitioned into time slots according to certain principles of the present invention.

Fig. 5 is flow chart illustrating a method to establish communication and program a transceiver device with a communication code according to certain principles of the present invention.

20 Fig. 6 is a flow chart illustrating a method of activating an initialization process to program a transceiver device with a communication code according to certain principles of the present invention.

Figs. 7A and 7B are state diagrams illustrating transceiver modes of operation according to certain principles of the present invention.

25 Fig. 8 is a timing diagram of a remote transceiver device paging a base transceiver to establish communications according to certain principles of the present invention.

Figs. 9A and 9B are state diagrams illustrating transceiver modes according to certain principles of the present invention.

30 Fig. 10 is a timing diagram illustrating how multiple transceiver devices share bandwidth according to certain principles of the present invention.

Fig. 11 is a timing diagram illustrating how multiple transceiver devices share bandwidth according to certain principles of the present invention.

Fig. 12 is a timing diagram illustrating how bandwidth can be dynamically allocated to a new remote transceiver according to certain principles of the present invention.

Fig. 13 is a timing diagram illustrating a method of implementing diversity checks according to certain principles of the present invention.

Fig. 14 is a block diagram illustrating how multiple transceiver devices can communicate with each other over a shared inductive bandwidth according to certain principles of the present invention.

Fig. 15 is a timing diagram illustrating time slot assignment of multiple pairs of communicating transceiver devices according to certain principles of the present invention.

Fig. 16 is a block diagram of multiple transceivers and corresponding transducer elements according to certain principles of the present invention.

Fig. 17 is a block diagram illustrating a method of implementing diversity checks according to certain principles of the present invention.

## DETAILED DESCRIPTION OF THE INVENTION

A description of preferred embodiments of the invention follows.

Fig. 1 is a pictorial diagram of a wireless communication system according to certain principles of the present invention. As shown, wireless communication system 100 includes cellular phone device 130 and headset 110. Generally, headset 110 is worn by a user to communicate with a remote party over one or multiple wireless links. For example, inductive link 122 supports communications between a user wearing headset 110 and cell phone 130. Radio Frequency (RF) link 127 supports communications between cell phone 130 and cellular base station 125. Base station 125 is coupled to network 129 such as a PSTN (Public Switching Telephone Network).

Instead of holding cell phone 130 to one's ear as is ordinarily done to communicate over a telephone with a remote party, a user wearing headset 110 can

communicate with the party using headset 110. For example, a user can speak into microphone 112 to convey a voice signal to a remote party through inductive link 122 and RF link 127. In a reverse direction, voice signals generated by a remote user at the other end of phone 130 are conveyed through RF link 127 and inactive link 122 to headset 110. The voice signal received at headset 110 are generated over speaker 180.

Speech generated by a user is detected by microphone 112 and modulated onto an inductive carrier frequency of inductive link 122. The inductive signal including voice information transmitted from headset 110 is received and demodulated at base transceiver 120. Base transceiver 120 converts the voice signal into a protocol accepted by cell phone device 130. Cell phone 130 receiving the voice signal transmits it over wireless link 127 using standard techniques such as those based on use of CDMA (Code Division Multiple Access) technology..

In a reverse direction, signals generated by the remote party at the other end of phone 130 are communicated through base station 125. The signals are formatted for transmission over radio link 127 to cell phone 130 using standard protocols. The signal received at phone 130 is then reformatted into an appropriate protocol for reception at base transceiver 120 that processes the signal and re-generates the information over inductive link 122 to headset 110. Accordingly, a sound output that is otherwise generated at cell phone 130 is instead generated at speaker 180 for a user wearing headset 110.

While wearing headset 110, a user can communicate hands-free without otherwise being entangled in wires connecting cell phone 130 and headset 110. According to one aspect of the present invention, inductive coupling techniques are used to minimize the size and therefore the burden of wearing or using headset 110.

In one application, headset 110 communicates with base transceiver 120 up to several meters away. Thus, cell phone 130 can be held at a distance from user or, at a minimum, away from the user's head.

Although communication system 100 is directed towards a wireless headset device, it should be noted that a combination of base transceiver 120 and remote transceiver 116 can be used in other wireless applications as well. For example,

base transceiver 120 can be coupled to a wired-telephone device so that a user can communicate hands-free while wearing headset 110 in an office setting or the like. Additionally, the transceivers can be used in other short range applications where the use of inductive technology for wireless voice or data transmissions is appropriate.

5           Base transceiver 120 can include electronic components housed in a rigid body made from plastic or other durable material. In one application, base transceiver 120 is removably attached to cell phone 130. Alternatively, base transceiver 120 is coupled to cell phone 120 using a cable wire through a 2.5 mm jack or other suitable phone connector. In yet another application, base transceiver  
10 120 is integrated into cell phone 130 so that it does not protrude from the end of cell phone 130.

          While in an operational state, communication system 100 can utilize TDD (Time Division Duplexed) techniques to communicate. More specifically, a usable bandwidth at a chosen carrier frequency such as 12 MHz can be partitioned into time  
15 slots shared by two or more communicating transceivers. An advantage of using inductive technology is the reduced interference among multiple users that share use of a common carrier frequency. Typically, inductive communication signals are very difficult to detect at distance greater than several meters away, so the effects of an inductive field generated by one remote user can be negligible to another remote  
20 user. However, techniques discussed in this specification can be used to reduce interference with users within close range of each other.

          Fig. 2 is a block diagram illustrating electronic circuitry supporting inductive communications according to certain principles of the present invention. As shown, base transceiver 120 can include three orthogonally disposed transducer elements,  
25 each of which can be dynamically tuned for transmitting and receiving information over inductive link 122. Remote transceiver 116 can include a single transducer element 166 for transmitting and receiving information over inductive link 122. Based on this topology, base transceiver 120 and remote transceiver 116 can maintain continuous communication regardless of their orientation relative to each  
30 other.

Although base transceiver 120 is shown including three transducer elements, namely, x-transducer 136, y-transducer 137 and z-transducer 138, the number of transducers used in an application can vary. For example, base transceiver 120 can include as few as only a single transducer or as many transducers that fit in a transceiver device. Similarly, remote transceiver 116 can include any number of transducers such as three orthogonal transducers to support bidirectional communications with base transceiver 120.

Typically, an appropriate number of transducers are employed in each transceiver device so that base transceiver 120 and remote transceiver 116 can communicate with each other regardless of their orientation or position using inductive fields. In certain applications, fewer transducers are necessary in a transceiver because it is known that certain orientations of the transceivers relative to each other are not possible or alternative transducer configurations produce the required magnetic field for communication.

Either transceiver device can be fixed so that its orientation does not vary with respect to a complementary transceiver. However, in the application as mentioned in Fig. 1, an orientation of either transceiver device can vary. For example, a user carrying phone 130 in his pocket while walking can enjoy continuous connectivity with phone 130 over headset 110. In this case, both transceiver devices are subject to random orientation and position.

As shown in Fig. 2, base transceiver 120 can include controller 115 such as an ASIC (Application Specific Integrated Circuit), which is electrically connected to tuner circuit 130 via transmit lines 132, receiver lines 133, and switch control lines 134. Tuner circuit 130 is connected to a set of three orthogonal transducers, including x-transducer 136, y-transducer 137, and z-transducer 138. In general, tuner circuit 130 can select a transducer element and adjust its characteristics for transmitting and receiving inductive signals.

Base transceiver 120 can be also electrically and logically connected to base crystal 129, memory 125 such as EEPROM, audio line 135, audio/data line in 140, control/status line 141, and power source 190.

Remote transceiver 116 can include controller 145, which is electrically connected to tuner circuit 160 via remote lines 162, receive lines 163, and switch control lines 164. Remote transceiver 110 can also include remote crystal 150 frequency source, memory 155 such as EEPROM, audio/data line out 170,  
5 audio/data line in 165, and volume control line 185. In a voice application as mentioned, headset 110 includes microphone 175 and speaker 180. Power source 195 can be used to power circuitry in remote transceiver 116.

In one application, controller 115 and controller 145 utilize Time Division Duplexing (TDD) and Gaussian Minimum Shift Keying (GMSK) to transmit and  
10 receive data information.

If used, custom-designed CMOS (Complementary Metal Oxide Semiconductor) chips support full duplex transmission of audio and data. Other circuit technologies can be used but may not necessarily provide the low power and design advantages that CMOS semiconductor chips provide.

15 Typically, crystal 129 and crystal 150 are 9.8 MHz frequency sources. Other suitable crystals can be used depending on the application.

Memory 125 and memory 155 can be EEPROM (Electrically Erasable Programmable Read Only Memory). Each memory device can include grounding pins that identify the "personality" of a transceiver device (e.g., a mouse, a keyboard,  
20 or gaming joystick, Personal Digital Assistant, stereo, global positioning system, radio, MP3 player). Accordingly, the grounding pins can be used to select specific software functions for use in a particular transceiver device.

X-transducer 136, y-transducer 137, z-transducer 138, and single transducer 166 can be transducer coils having a ferrite core. Microphone 175 can be a  
25 miniature microphone such as Panasonic part number WM-66DC103. Typically, power source 190 and power source 195 are rechargeable button cells such as NiMH 40mA-Hr units.

In a phone application as discussed in Fig 1, controller 115 receives audio or data information via input audio/data line 140, converts the received information  
30 from analog to digital for processing (if it is analog audio), and drives the information to impedance tuning circuit 130 that drives x-transducer 136, base y-

transducer 137, and base z-transducer 138 for transmission. The transducers generate a magnetic induction field 122, such that remote headset unit 110 receives the transmitted signals. Transmitted signals on inductive field 122 are received by remote unit transducer 166. The signals are sent to controller 145 and are converted  
5 to a digital protocol for processing. Raw digital data is then converted to an analog signal to drive speaker 180. The process may also be reversed such that remote headset unit 110 sends signals to base transceiver 120.

Logic within controller 115 and controller 145 controls base and remote switch lines 134 and 164 in order to operate tuner circuits 130 and 160 that are used  
10 to adjust characteristics of the transducers. Base and remote transmit lines 132 and 162, and base and remote receive lines 133 and 163 assist in operating base unit 105 and remote unit 110 in either transmit or receive mode. Base and remote transmit lines 132 and 162 support the operation of base unit 105 and remote unit 110 at maximum power and low impedance for transmitting; while base and remote receive  
15 lines 133 and 163 support a parallel tuned network for receiving.

In one application, power source 190 and power source 195 are battery devices. In other applications, base power source 190 and second power source 195 can be supplied through an automobile cigarette lighter, or may be directly supplied via wall current.

20 Base and remote control/status lines 141 and 185, can be used to "wake up" the devices from a very low-power operating mode. In another example, base and remote control/status lines 141 and 185 can be used to instruct controller 115 and controller 145 to "page" the other device to "wake-up" a link. Instructions for controlling these communications can be stored in memory 125 and 155.

25 Fig. 3 is a block diagram of a point-to-multi-point inductive communication system according to certain principles of the present invention. As shown, base transceiver 120 can maintain communication with one or multiple remote transceivers 116-1, 116-2...116-n over respective inductive links 122-1, 122-2, ...122-n. As discussed, each transceiver can include as few as a single transducer  
30 element or multiple orthogonal transducer elements. Briefly, Fig. 14 is a block

diagram of yet another topology in which multiple transceivers communicate with each other. This will be discussed in more detail later in this specification.

Fig. 4 is a timing diagram of a time-slotted inductive communication system according to certain principles of the present invention. Each frame 462 includes  
5 field A and field B for transmitting and receiving data in respective time slots or data fields. Although diagram 400 depicts an approximate ratio of 50% transmitting to 50% receiving between transceivers, apportionment of a bandwidth and use of particular data fields can vary depending on the application.

Both field A and field B are broken down into four transmit time slots 405  
10 and four receive time slots 410 that alternate in a time sequence. An additional time slot can be used for link management. For example, a time slot such as diversity slot 492 in field A and B can be allocated for diversity checks, which are noted as TX-A and TX-B.

A diversity check is used to test whether other uniquely oriented transducer  
15 devices support more efficient communications. More specifically, a diversity time slot 492 can be used by base transceiver 120 or remote transceiver 116 to monitor a quality of a received signal transmitted on a different transducer axis. If one transducer coil provides better coupling, *e.g.*, greater detected signal strength at a receiver, future bit information can be transmitted or received on that transducer  
20 coil.

It should be noted that there are a number of ways to implement diversity  
checks. For example, in one application, a transceiver device can potentially include three orthogonal transducers, namely, x-transducer 136, y-transducer 137 and z-transducer 138. Each of the three axes of the individual transducers can be tested to  
25 determine whether a link between a single transducer and either x, y or z is more optimal. More specifically, a signal can be transmitted to transducers x, y and z. It can be determined which of the three axes is optimal for transmitting based on a comparison of which transducer receives a strongest received signal. This is one possible method of performing a diversity check.

30 Additional axes can be tested in addition to those of each transducer device x, y and z. For example, multiple transducers can be simultaneously selected to

transmit or receive an inductive field. Thus, combinations of additional axes produced by simultaneously activating transducers x-y, transducers y-z, and transducers x-z can be tested using additional diversity checks. Also, all three transducers can be activated simultaneously to produce yet another axis on which to  
5 perform a diversity check.

A preferred combination of transceivers can be calculated based upon results from the individually energized transducers. For example, if equal signal strength is received on all three transducers during diversity checks, it can be assumed that the preferred axis can be achieved by selecting all three transducers to transmit or  
10 receive an inductive field.

It should be noted that Fig. 4 is a timing diagram with respect to a first transceiver. A complementary timing diagram for the another transceiver communicating with the first transceiver would have opposite time slots for receiving and transmitting data information in data fields 405 and 410. In other  
15 words, while one transceiver transmits, another transceiver receives.

Using an appropriate carrier frequency of 13.56 MHz, 296 data bits of information can be transmitted or received in a time slot or 4,896 bits (24 milliseconds) can be transmitted in frame 462.

Each transmit time slot 405 and receive time slot 410 can be used to transmit  
20 or receive 296 bits of information. A majority of the 296 bits in each slot can be used to transmit or receive data information. The other bits in a time slot can be used for command, control, or error correction/detection.

Guard bits 420 (16 bits) and 460 generally serve as a buffer zone between time slots. Typically, use of guard bits 420 allows transients as a result of  
25 transmissions in a last slot to diminish before data processing begins on data transmitted in a new time slot.

Preamble bits 425 (24 bits) can be a predetermined bit sequence of alternating ones and zeros. This sequence of bits can be used to adjust timing and synchronize transceivers.

30 Synchronization bits 430 (16 bits) can be a coded sequence of predetermined random bits that are used to synchronize a receiver with a transmitting transceiver

and indicate start of data. When the received sequence of bits match the sequence in the receiving transceiver, the devices are synchronized with respect to the start of further transmissions.

5 An FEC (Forward Error Correction) code is optionally included in a time slot to ensure that bit information is properly received in a time slot.

LDATA bits 440 are generally used to maintain a link by controlling gain, transmission power, frequency channel management, diversity, device unique identifier or communication codes. These bits can be command bits that identify a specific command to be executed by a remote transceiver device. For example, a  
10 change in the remote unit transmitter power level can be controlled via a command. In the case of a change in the remote unit's transmitter power, these bits would specify the level.

A list of commands that can be sent between transceivers includes commands for: controlling gain of signals, changing transmit power level, selecting  
15 transducers, selecting magnetic field direction, changing communication codes, requesting bandwidth changes, changing bandwidth allocation among multiple devices, changing the length of transmit and receive time slots, changing communication frequency, allocating communication time slots among multiple devices, and changing operating parameters of controller 130 and controller 145.

20 Commands can also be used to control one transceiver remotely from another transceiver. In one embodiment, volume control buttons of phone 130 may be used to control volume of speaker 180 in headset 110 by transmitting commands in slot 440. Similarly, one transceiver may be powered off by another transceiver on remaining battery power in transceiver may be monitored by a display in another  
25 transceiver. Thus headset 110 can be made "switchless" so that all functions, such as volume control and operating power level are controlled by phone 130. Functionality of a "switchless" headset can be further enhanced if field orientation and field strength are also used to control the functions of the headset.

In one embodiment, LDATA bits 440 are subdivided as follows: an FEC  
30 (Forward Error Correction) code of 6 bits to ensure that bit information is correctly received in a time slot; a slot ID of 2 bits which identifies which of the four

transmit/received pairs in a frame is currently being transmitted; a command name of 8 bits that identifies the specific command being transmitted between transceivers; and command data of 16 bits that contains data specific to the command. Use of a slot ID can be advantageous since it enables the slots to be  
5 randomized within the frame and then sorted into proper order at the receiving unit, thereby minimizing the impact on audio quality of missing or corrupted data.

The LDATA command name and command data may also include the exclusive communication code as an alternative embodiment of a dedicated communication code 470. In this alternative embodiment, the communication code  
10 is transmitted in slots whenever commands are not required, and thus the communication code would fill otherwise "empty" command and data bits. This is advantageous in that it requires less bandwidth whereas a separate bit allocation 470 ensures that every slot has the communication code.

Communication code 470 can be a 16-bit code that uniquely mates a base  
15 transceiver and one or more other transceiver devices. This code can be an at least partially random code that is passed from base transceiver 120 to remote transceiver 116 upon initialization. Code 470 can also be programmed during manufacturing. If a code received in this data field is not recognized by a receiving transceiver device, following data information can be ignored. Consequently, communication  
20 code 470 can be used to support exclusive communications with one or multiple other transceiver devices.

In one embodiment, a 16-bit code includes a 10-bit random number that is unique to all devices in a multi-point communication system, a 3-bit number unique to each transceiver device in a multipoint system (optionally set to a null value when  
25 broadcasting to all transceiver in a multi-point system), and a 3-bit unique to a type of device. In another application, the code can be a 16-bit value for each exclusive device and thus a unique code is stored for each device.

Each transmit time slot 410 and receive time slot 405 can include a field 450 that is used to transmit or receive payload data. These bits can include CVSD  
30 encoded audio data. Since one side of the system transmits only half the time,

enough data must be in this 192 bit interval so that the user will not perceive an interruption in the audio.

As mentioned, diversity check slot 492 enables the base unit to assess whether the current transducer selected for transmitting and receiving is acceptable.

- 5 Generally, base transceiver 120 monitors the received signal quality on a different transducer axis. Based on a link quality, such as received power, received noise, or bit error rate, a transceiver can determine whether to continue using a current transducer to transmit or receive or to switch to use of another transducer.

10 Fig. 5 is a flowchart illustrating a method of communicating according to certain principles of the present invention. Generally, flowchart 500 is a technique for establishing an exclusive or at least partially exclusive relationship between multiple transceivers based on use of a communication code 470.

15 More specifically, base transceiver 120 can determine whether a message received from a remote transceiver 116 includes a valid communication code 470 indicating that the transceivers have been initialized for communications. Use of a communication code 470 ensures that data messages generated for an exclusive communication between base transceiver 120 and remote transceiver 116 are not accidentally or intentionally picked up by another user transmitting and receiving over the same carrier frequency. Thus, a phone call supported by headset 110 can be  
20 secure so that eavesdroppers do not listen in on a private call.

Flowchart 500 describes two methods to link a remote transceiver 116 to a base transceiver 120 for private bidirectional communications. If base transceiver 120 and remote transceiver 116 have not yet been initialized with each other, the transceivers can be initialized with a communication code 470. After a transceiver  
25 has been initialized or if the transceivers have already been initialized with a communication code 470, flowchart 500 illustrates a method of establishing bidirectional communications between transceivers.

In step 510, power is applied to headset 110. Headset 110 is moved within detectable range of base transceiver 120 in cell phone 130. This is typically less than  
30 2 meters.

Depending on recent use, base transceiver 120 coupled to cell phone 130 can be set to a sleep mode to conserve battery power. While in the sleep mode, base transceiver 120 intermittently listens for paging signals from remote transceiver 116 coupled to headset 110.

5           After applying power to headset 110 in step 510, remote transceiver 116 enters a sleep mode in which remote transceiver 116 is dormant. Generally, minimal circuitry is powered to reduce power consumption, yet selected circuitry in headset 110 remains powered to enable the device to turn on quickly if an activation signal is received. For example, features of a transceiver can be shut down except the clock  
10           and microprocessor, which can run at a reduced duty cycle. At predetermined time intervals, each transceiver can "wake up" to check for an activation signal, such as user input or receipt of a paging signal from another device. If no activity is detected a transceiver remains in a low power or sleep mode.

          In step 520, remote transceiver detects whether an activation condition has  
15           occurred. One such activation may be detection of throwing a switch or turning a volume control on headset 110. The activation signal can vary depending on the application.

          If no activation signal is detected in step 520, remote transceiver 116 remains in the sleep mode. However, when an activation signal is detected in step 520,  
20           process flow continues at step 522, which causes the remote transceiver to enter a paging mode.

          While in the paging mode, remote transceiver 116 of headset 110 transmits a repetitive stream of data information to base transceiver 120. A protocol for transmitting the data was previously discussed in Fig. 4. Generally, the remote  
25           transceiver 116 generates a data sequence and listens during interleaved time slots for acknowledgment messages from base transceiver 120.

          A paging signal can include a unique sequence of bits so that a receiving transceiver can identify it as a paging signal. If a link is not established within a predetermined time frame, the system reverts to a power saving "low-power" mode.

Fig. 8 is a timing diagram more particularly illustrating transmission of a paging signal by remote transceiver 116 while it is in the paging mode. Multiple messages can be transmitted in a sequence of frames.

While in the sleep mode, base transceiver 120 attempts to detect paging signals on each of three transducer elements during different time intervals. Based on orientation, it is possible that one or even two of the transducers in base transceiver 120 can not detect the paging signal generated by remote transceiver 116. To account for this condition, base transceiver 120 intermittently listens on each of different transducer elements during different time durations to detect paging signals from remote transceiver 116. At least one transducer in base transceiver will be able to detect a paging signal.

The process of receiving a signal on different transducers can be achieved by including a multiplexer circuit in base transceiver 120 so that a corresponding receiver can be selectively coupled to each of different transducers at different times. A use of a multiplexer circuit can reduce the number of receivers in a transceiver device.

While in the sleep mode, base transceiver 120 does not necessarily transmit information as shown in the timing diagram of Fig. 4. Rather, base transceiver 120 occasionally listens for paging signals transmitted by a remote transceiver 116. A sequence of bits in a paging message such as preamble bits 425 and sync bits 430 can be used to synchronize base transceiver 120 and remote transceiver 116.

Since base transceiver 120 and remote transceiver 116 can initially be out of phase with each other prior to establishing a formal two-way communication link, remote transceiver 116 can shift the phase of the paging signal so that it eventually can be detected by a base transceiver 120 in the sleep mode. In one application, remote transceiver 116 shifts the phase of its timing by 180° or some incremental amount after determining that no signal was received within a time period. Thus, base transceiver 120 can eventually detect a transmitted paging signal if it is within range of remote transceiver 116.

Based on this technique, if both transceivers are transmitting and receiving at the same time, one transceiver can shift the phase of its transmit and receive cycle relative to the second device so that the transceiver devices can communicate.

Referring again to Fig. 5, if base transceiver 120 does not respond to the presence of a paging signal transmitted by remote transceiver 116 in step 524, process flow continues to step 526, which determines whether a timeout has occurred. If base transceiver 120 does not respond within a time period of several seconds or other predetermined amount of time, it is presumed that there is no base transceiver 120 with which to connect and remote transceiver 116 is set to the sleep mode again in step 515.

In the event that remote transceiver 116 receives a response from base transceiver 120 in step 524 as a result of transmitting a paging signal, process flow continues at step 530. It is determined in step 530 whether base transceiver 120 acknowledges that a valid communication code 470 was transmitted by remote transceiver 116 in a previous paging message. For example, if a communication code 470 was previously established for use between headset 110 and cell phone 130, this code can be sent in paging signals from remote transceiver 116. Thus, base transceiver 120 can determine, based upon receipt of a paging signal and value of a communication code 470 in the paging message, whether remote transceiver 116 has been initialized with a non-factory programmed communication code 470. More specifically, a base transceiver 120 can determine whether it previously communicated with remote transceiver 116 based on code 470. A factory programmed code can be unique such as all zeros so that the base transceiver 120 can determine whether remote transceiver 116 has ever been previously initialized. Alternatively, a unique communication code for a "matched" headset 110 and base can be factory programmed prior to shipment.

If base transceiver 120 sends a message to remote transceiver 116 that it did not receive a valid or recognized communication code 470 in a received paging signal in step 530, process flow continues at step 535 where the remote transceiver 116 checks and waits for a queue indicating a desire by a user to initiate an

initialization process for establishing a communication code 470 between headset 110 and cell phone 130.

The queue for initiating the initialization process to establish a communication code 470 can vary depending on the application. For example, the method of queuing a remote transceiver 116 can involve steps as shown in Fig. 6. In step 610, base transceiver 120 and remote transceiver 116 can be moved in close proximity to each other, typically less than a foot apart. The proximity or changing proximity can be detected at base transceiver 120 based upon received signal strength.

Additional or alternative activating steps can be used to initiate the initialization process. For example, in step 620, a volume control or other switch on headset 110 can be held down by a user to initiate programming a communication code. An internal electronic signal generated by depressing the switch can be received at remote transceiver 116 can indicate a desire by a user to initiate the programming of a code 470. Thereafter, in step 630, the transceivers are optionally positioned or oriented by a user in a predetermined position with respect to each other to complete an activation process.

Base transceiver 120 can identify an orientation of a received magnetic field using a set of transducers to determine whether headset 110 and, more particularly, remote transceiver 116 is oriented in such a way as to indicate that a user would like to initialize headset 110 and cell phone 130 with a communication code 470. Following detection of the appropriate activation routine, bidirectional communications are established between transceivers to program a new communication code 470.

Other activation protocols can be used to initiate programming of a communication code 470. In one application, a strength of an inductive field received at base transceiver 120 is used to determine that a user has initiated the initialization process. It is known that the strength of a received field is a strong function of distance between transceiver devices. Consequently, a transceiver device can detect whether a received signal is above a threshold to determine that the devices are in close proximity. By measuring a signal strength, and therefore

approximate distance, an additional constraint can be used to determine a user's intent to program the devices with a communication initialization code.

As mentioned, an orientation of a received inductive field can be used to activate the initialization process. For example, an inductive field can be received  
5 on each of multiple transducer in a transceiver device to determine an orientation of the inductive field and therefore remote transceiver 116. Based on measured characteristics, an orientation of the device transmitting the inductive field can be determined.

In yet another application, a changing orientation over time of, for example, a  
10 remote transceiver device relative to another sensing transceiver device can be used to activate an initialization process. More specifically, a headset can be successively and rapidly moved near and far relative to a base transceiver to initiate the initialization process. Also, a headset device can be rotated or moved in a circular fashion to initiate the initialization process.

15 A combination of conditions can be a prerequisite to activating the initialization function. For example, a user can press a "program" button to enter a mode in which one or more conditions must be satisfied within a time window for the two devices to proceed programming a new communication code 470 as previously described. Thus, causing an activating condition outside the window  
20 during normal bidirectional communications will not cause the transceiver device to become programmed with a new communication code 470.

One method of determining proximity includes sensing a strength of a received signal on each of multiple transducers in a transceiver device. Similarly, proximity can be determined by detecting a strength of signals on a single transducer  
25 received from multiple transducers transmitting at different times.

Fewer transducers can be used if the orientation is predictable relative to the direction of the field being sensed, such as would be possible if a game controller was limited to only one or two degrees of freedom of motion relative to a fixed field generating transducer in a base device.

-24-

Range, R, (to a first approximation) is typically a function of the magnetic field strength M that is measured by the field sensing coils and varies in accordance with the following proportional formula:

$$M = \sqrt{a_x^2 + a_y^2 + a_z^2}$$

5 
$$R = K \cdot \sqrt[3]{M}$$

where a is the amplitude of signals measured by the x, y and z coils, respectively, and K is a proportionality constant. An advantage of the applying the formula above for determining distance between transceivers is that ranging is achieved based on amplitude of a received signal rather than the phase of the signal on each transducer.

10 Phase relationships of a detected signal can also be used to determine orientation of a transceiver device.

Based on characteristics of transceiver devices and the equations above, an inductive field can be analyzed to determine the position and orientation of a transceiver.

15 In one application during the initialization process, a first device with more than one transducer can be restricted to use less than the total number of transducers when communicating with a second device. Thus, physical orientation can be a condition for initializing two devices. For example, a remote unit such as a headset 110 may have to both be in close proximity and oriented with respect to phone 130  
20 for the initialization process to be initiated. In such an embodiment one transducer, for example, X-transducer 136 in the base transceiver 120, can be exclusively used for initialization, the signal strength on the x transducer would have to exceed a threshold while the remaining transducers would fall below a second threshold. More specifically, orientation of a transceiver can be determined by detecting that  
25 the strength of a received signal is above a threshold value for one transducer axis while the strength of a received signal is below corresponding thresholds for two other transducer axes.

One method of determining an orientation of transceivers is based upon measuring a relative strength of received signals on multiple predetermined axes. For example, a strength of received signals on each of three orthogonal transducers x, y and z can be used to identify a relative angular orientation of a transceiver.

5            Assuming that a pair of transceivers communicating with each other do not substantially change their orientation during a major cycle, a proportion of signal strengths can be used to define a vector of a received inductive field. The vector can be used to approximate a relative positioning of base transceiver 120 with respect to remote transceiver 116. For example, measurements of a first sample reading on  
10 three orthogonal transducers can result in a 0% received signal on transducer x, 0% received signal on transducer y, and 100% received signal on transducer z. As mentioned, the proportion of received signal strength identifies a relative orientation of the transceiver at the time of the first reading. At a later reading and after a change in orientation of transceivers relative to each other, signal strengths can be  
15 measured again. If the new readings result in a 100% received signal on transducer x, 0% received signal on transducer y, and 0% received signal on transducer z, it can be assumed that the transceivers are now in a new relative orientation with respect to each other. More specifically, based on the two readings of sample data, it can be assumed that the relative angular orientation of the transceivers relative to each other  
20 has changed by 90 degrees. Consequently, an angular change in three dimensional space can be estimated based on comparison of measured received signal values at different times. A rate of change of orientation can be determined by measuring the relative positions of a transceiver device at different times.

In one application, an activation signal to answer a phone call can be a  
25 motion of rotating headset 110 ninety degrees in less than a 1 second time window. For example, a change in headset orientation can be sensed at either base transceiver or remote transceiver 116 using the technique as previously discussed. When a proper predetermined motion is detected, a paging signal can be generated by a sensing device to establish a communication link between transceivers so that user  
30 can answer a call merely by picking up headset 110 and placing it on his head. Hence, it is not necessary to press a button to activate receiving a call.

Referring again to Fig. 5, if a queue such as one of the above-mentioned activation protocols is not detected within a timeout period in step 540, process flow continues at step 542 to determine whether a timeout occurred. If so; remote transceiver 116 enters the sleep mode in step 515. If not, remote transceiver 116  
5 continues in the paging mode in step 522.

If a queue is detected within a predetermined timeout period in step 540, process flow continues at step 545 in which a communication code 470 is established for exclusive communications between headset 110 and cell phone 130. Typically, base transceiver 120 generates a unique communication code 470 and  
10 transmits it to remote transceiver 116. Conversely, a remote transceiver 116 or a combination of transceivers can generate communication code 470.

Both transceiver devices can store code 470 in non-volatile memory for later retrieval. Additional bidirectional communications can be used to confirm that a communication has been properly established.

15 After establishing a communication code 470 in step 545, process flow then continues at step 555 in which bidirectional communications are supported between headset 110 and cell phone 130 using the new communication code 470.

If base transceiver 120 responds to remote transceiver 116 in step 530 indicating that a valid communication code 470 was detected in a paging message, it  
20 is noted that the transceivers have already been initialized for exclusive one-way or bidirectional communications. Process flow would then also continue at step 555.

After establishing a communication link between transceivers, it is determined in step 560 whether an out-of-range condition is detected during a conversation. For example, communication between headset 110 and cell phone 130  
25 may cease as a result of separating the transceivers so far apart that corresponding transmit signals can not be detected at either transceiver device.

If the transceivers reestablish communication as a result of moving the devices in range with each other again, it is determined in step 570 whether the re-connection has occurred within a timeout period. If so, process flow continues at  
30 step 555 to resume previous communications. If not, headset 110 is set to the sleep

mode to conserve battery resources because it is assumed that the previous link has terminated.

If no out of range condition is detected in step 560, it is determined in step 565 whether a terminate command has been received indicating a desire by a user to terminate the active link between base transceiver 120 and remote transceiver 116. If not, communications continue again in step 555. If so, remote transceiver 116 and base transceiver 120 are set to sleep mode in step 515 in order to conserve power. Terminate commands can be any of the activating type of conditions as previously discussed. More specifically, a terminate command can be detected by sensing a proximity, orientation or motion of a transceiver device.

After a transceiver device is initialized to uniquely associate it with another transceiver device, other devices can ignore such communications. For example, consider that two cell phone users each having corresponding headsets are in range of each other. According to the principles of the present invention, the first user can use his cell phone and headset without worrying about the second user turning on his headset and eavesdropping on a private communication because the communication code sent in each message will not be known by the second user's headset or cell phone. Multiple devices for multi-point communication can be initiated in a similar manner. For example, one base transceiver can be initialized to two headsets via two different communication codes. This enables a single headset to communicate with multiple transceiver devices. More specifically, a headset can be programmed to communicate with a wireless phone and, alternatively, a second base transceiver coupled to a wired phone in a user's office. Initialization can be required only once per transceiver-to-transceiver relationship since the communication code or communication codes can be stored in non-volatile memory.

In one application, base transceiver 120 is held physically close to remote transceiver 116 and a deliberate action, such as holding a power on/off switch for an extended period of time, is performed by a user to initiate the initialization process. This activation routine can trigger firmware stored in memory 125 or remote memory 155 to generate a communication code 470 that uniquely identifies the base-remote transceiver relationship 110.

Portions of the communication code can identify different aspects of a transceiver device. For example, a communication code 470 can identify a type of device ( *e.g.*, a type of headset, PDA, joystick, mouse, keyboard...), a version of operating firmware, a master-slave relationship, number of transducers in a  
5 transceiver device, or protocol for transmitting and receiving data.

Information transmitted in a data field transmitted from a transceiver can be encrypted so that only a user programmed with a proper communication code 470 can decode received data messages. In this instance, a communication code is not sent in each message. Rather, a communication link is established between  
10 transceiver devices and each transceiver encrypts and decrypts the data based upon a code known only to the transceiver device.

Once base transceiver 120 and remote transceiver 116 are initialized to each other via code 470, both devices store the unique paired device identifier code in nonvolatile memory until erased by a second predetermined action. The protocol to  
15 erase or reprogram a communication code can be similar to those previously discussed to activate the initialization process.

It should be noted that orientation and proximity of two or more transceiver devices can be used to control other aspects of communication system 100. For example, if a headset "docking" station (*e.g.*, a station in which a headset can be  
20 secured to a slot or hook in cell phone 130) is used to secure a headset 110 to phone 130 when not in use, the orientation and proximity of headset 110 relative to the phone 130 can be used to identify that a phone call has been terminated. More specifically, a user can complete a call and move the headset in a specific predetermined relation to cell phone 130 to terminate a call. Base transceiver 120  
25 can detect this motion as previously discussed and, in response, automatically shut off power to the phone. Accordingly, a call may be terminated more simply than is otherwise necessary using buttons or other mechanical components.

Base station 120 can also monitor the movement of headset 110 to determine that a call is being initiated by a user removing the headset from a resting  
30 position such as a docking station. In other words, removing the headset from the docking station can cause either or both the headset and base transceiver to become

powered and establish a communication link via paging signals. Accordingly, fewer push buttons and control features are necessary to activate a transceiver device. Also, the use of this contactless activation method is simple to use because the headset 110 must be detached from phone 130 to use anyway.

5 Figs. 7A and 7B are state diagrams illustrating different modes of an inductive communication system according to certain principles of the present invention. As shown, remote transceiver 116 can communicate with base transceiver 120 to establish a communication link as previously discussed in Fig. 5.

Initially, power is applied to headset 110 to enter the sleep mode in state 710.  
10 Remote transceiver 116 then waits for an input such as a "flash" condition in which a user activates the headset for use. The activation can be motion, pressing a button, or any activation as previously discussed. This causes headset 110 to enter the standby mode 715.

While in the standby mode 715, headset 110 and, more specifically, remote  
15 transceiver 116 generates paging signals and transmits them to base transceiver 120. Initially, base transceiver 120 is in standby mode 760 listening for paging signals. Upon detection of a message from remote transceiver 116, transceiver 120 enters acquire mode 765.

While in paging mode 715, remote transceiver 116 will retransmit a link  
20 request message until a response is received from base transceiver 120. If no response is received within time out period, remote transceiver 116 goes back into sleep mode 710. If a response is received from base transceiver 120, remote transceiver 116 enters either initialize mode 720 or active link mode 725 depending on whether base transceiver 120 received a valid communication code 470. If base  
25 transceiver 120 acknowledges receipt of a paging message from remote transceiver 116, a communication code is programmed in mode 720 if conditions are detected to activate programming a communication code. After a new code 470 is programmed, bidirectional communications are supported while remote transceiver 116 is in active link mode 725.

30 Base transceiver 120 enters corresponding modes to initialize a base-remote transceiver pair with communication code 470. For example, initialization mode

770 is used to link base transceiver 120 and remote transceiver 116 to establish a code, while active link mode 775 enables transceiver to communicate information over an active link.

5 Figs. 9A and 9B are state diagrams illustrating modes of an inductive communication system according to certain principles of the present invention. As shown, inductive communications system 900 is directed towards establishing a communication link between cell phone 130 and headset 110. However, it should be noted that such principles can be extended for use in other inductive wireless communication applications as well.

10 Initially, both base transceiver 120 and remote transceiver 116 in headset 110 wait in sleep modes 960 and 910, respectively. In addition to "ringing" a phone 130 to notify a user of incoming call, an active call signal can be detected by base transceiver 120 monitoring new calls based on appropriate electronic signals in cell phone 130. When a call is detected, base transceiver 120 enters paging mode 965.  
15 At this point, base transceiver 120 sends out paging signals to remote transceiver 116 to establish an active link.

In response to hearing ringing cell phone 130, a user activates headset 110 based on an action such as pressing a button or merely removing headset 110 from a docking station and positioning it on his head. This activation signal can be detected  
20 as previously discussed by remote transceiver 116 and causes remote transceiver 116 to enter paging mode 915. At this point, both base transceiver 120 and remote transceiver 116 are in paging mode increasing chances that both devices will detect each others presence to establish an active link. Recall that while in the paging mode, both transceivers also listen for acknowledgment messages from the other  
25 paging transceiver device.

If for some reason base transceiver 120 and remote transceiver 116 can not establish a link within a timeout period, both transceivers will enter a listen mode 920 and 970, respectively, to conserve power.

On the other hand, when base transceiver 120 and remote transceiver 116  
30 acknowledge receipt of paging messages from each other, base transceiver 120 and remote transceiver 116 enter active link modes 980 and 930, respectively. In these

states, base transceiver 120 and remote transceiver 116 communicate with each other by sharing a common bandwidth. If the transceivers accidentally become out-of-range with each other, base transceiver 120 and remote transceiver 116 will enter out-of-range modes 985 and 935, respectively, until a link is reacquired or a timeout  
5 occurs.

If a previous link is not reacquired within a timeout period, both base transceiver 120 and remote transceiver 116 enter listen modes 970 and 920, respectively. Both transceivers listen for paging signals from the other transceiver device.

10 If lost, a user can reinitiate a link by activating headset 110. For example, a user can press a button on headset 110 causing remote transceiver 116 to enter paging mode 915. When base transceiver 120 receives a paging message from headset 110 (listen mode 970), base transceiver 120 enters acquire mode 975. Messages are then sent between transceivers to cause both transceivers to again enter  
15 active link modes 980 and 930, respectively.

It should be noted that while base transceiver 120 and remote transceiver 116 are in listen mode 970 and 920, respectively, a user can optionally activate base transceiver 120 so that it enters paging mode 965. Upon receipt of a paging message from base transceiver 120, remote transceiver 116 will enter acquire mode 925 and  
20 eventually active link mode 930 if a base acknowledge message is received.

Fig. 10 is a timing diagram illustrating allocation of bandwidth to multiple transceiver devices communicating in an inductive communication system according to certain principles of the present invention. As shown, base transceiver 120 communicates with each of multiple remote transceivers #1, #2 and #3 (116-1, 116-  
25 2, and 116-3) during allocated communication cycles.

One aspect of the present invention involves partitioning a bandwidth so that multiple transceivers can communicate with base transceiver 120. Base transceiver frames 610 illustrate time slots in which data is either received from (denoted as R) or transmitted to (denoted as T) a corresponding remote transceiver 116.  
30 Communication cycles 612, 614 and 616 are used by respective remote transceivers 116 to communicate with base transceiver 120.

During cycle 612, communications are supported between remote transceiver #1 116-1 and base transceiver 120. In a first part of cycle 612 denoted by T, remote transceiver #1 transmits from a selected transducer (or axis as a result of transmitting on multiple transducers) to base transceiver 120, which receives the signal. In one application, base transceiver 120 receives on a single selected transducer such as x-transducer 136, y-transducer 137 or z-transducer 138, depending on which transducer supported the most robust communications as detected by prior communications.

Base transceiver 120 can be notified by remote transceiver #1 which transducer at base transceiver 120 resulted in a strongest received signal from previous communications via a message to base transceiver 120. Based upon receipt of this message, base transceiver 120 can transmit and receive on the preferred transducer or set of transducers.

During a second portion of cycle 612 denoted by T, base transceiver 120 transmits to remote transceiver #1 over a selected transducer while remote transceiver #1 receives the transmitted data information in the same time slot. Consequently, a pair of transducers, one disposed in base transceiver 120 and another disposed in remote transceiver #1, can be used to support communications between transceivers.

If an orientation of remote transceiver #1 changes with respect to base transceiver 120, a different pair of transducers of a transceiver pair can be selected for communications as a result of diversity checks.

A last portion of cycle 612 (as well as a last portion of cycle 614 and cycle 616) can be used to perform a diversity check to occasionally check if another transducer or set of transducers is more optimal for transmitting and receiving data than a previously selected transducer or transducer for transmitting and receiving data information.

In the timing diagram shown, a last portion of each cycle is dedicated for use as a broadcast mode in which a selected transducer (or combination of transducers) of base transceiver device 120 transmits an inductive field that is received by each of multiple remote transceivers. For example, in diversity check slot 658 of cycle 612,

base transceiver 120 can generate a signal from x-transducer 136. Each remote transceiver #1, #2 and #3 receives the signal and detects a quality of the received signal.

In later time cycles 614 and 616, base transceiver 120 transmits on y-  
5 transducer 137 and z-transducer 138 in respective diversity check slots 659 and 660. Again, remote transceivers #1, #2 and #3 receive and detect a quality of received signal in each diversity time slot. Each remote transceiver #1, #2, and #3 can then compare link qualities of signals received over each of the different combinations of transducer pairs to determine which combination of selected transducers supports an  
10 acceptable link quality. This method ensures that different transducers are at least occasionally tested to determine whether they would otherwise provide a higher quality or more robust communication link with a corresponding transceiver. Thus, continuous coupling can be maintained for multiple transceivers regardless of their orientation.

15 After determining a preferred transducer or set of transducers on which to transmit and receive, a message can be generated by remote transceiver 116 to notify base transceiver 120 which transducer or transducers should be selected to transmit or receive further information at least in the next communication cycle.

Cycle 614 illustrates time slots supporting bidirectional communications  
20 between base transceiver 120 and remote transceiver #2. Similarly, cycle 616 illustrates time slots supporting bidirectional communication between base transceiver 120 and remote transceiver #3. As previously discussed for remote transceiver #1, remote transceiver #2 and #3 can determine which transmit or receive axis supported by base transceiver 120 should be selected in corresponding  
25 cycles to communicate with a remote transceiver.

Based on an orientation of each remote transceiver 116, a single transceiver can communicate with multiple remote transceiver regardless of their orientation. An advantage of this technique is efficient use of bandwidth since a transmission from a transceiver can be simultaneously received by multiple transceivers to  
30 determine link quality for different links.

It should be noted that the duration of time slots is not necessarily to scale as illustrated in Fig. 10. For example, as shown, a diversity check slot can include around 2% of time in cycle 612, while transmit and receive slots are partitioned to approximately 49% each. This partitioning can vary depending on the application.

5 In lieu of partitioning slots as shown in Fig. 10, each cycle 612, 614, and 616 can include multiple interleaved transmit-receive time slots as shown in field A or field B of Fig. 4. Consequently, a remote transceiver 116 can notify base transceiver 120 early in a cycle which of multiple transducers should be used for further communications. Such a message is optionally incorporated in data field 440,  
10 reserved for link control commands.

Although cycle 612, cycle 614 and cycle 616 illustrate that base transceiver 120 receives in first part of cycle, a sequence of which transceiver transmits or receives first can vary depending on the application.

Fig. 11 is a timing diagram including a portion of bandwidth allocated for  
15 paging signals according to certain principles of the present invention. As shown, cycle 1105 is reserved for paging transmissions from either remote transceiver 116 or base transceiver 120. Consequently, base transceiver 120 can page other transceivers and detect paging signals from other transceivers that are not presently allocated bandwidth.

20 It should be noted that a paging signal can include a code identifying a target transceiver in which it is trying to establish a communication link. For example, a base transceiver can transmit a paging signal including a communication code 470 of the transceiver device with which it is attempting to establish communications. Only the transceiver or transceivers having a code will respond with an  
25 acknowledgment message.

In one application, timing diagram 1100 is fixed to support a predetermined number of remote transceivers. As each new remote transceiver 116 request assignment of time slot usage, they are assigned use of cycle 612, cycle 614 or cycle 616 if they are not in use. A single remote transceiver can be assigned any number  
30 of minor cycles.

Before generating a paging signal as a result of being activated by a user, a transceiver device can listen to other transceiver transmissions to determine whether a link presently exists between base transceiver 120 and a remote transceiver. If so, a remote transceiver attempting to establish a communication link can determine  
5 when cycle 1105 occurs in a major cycle. Accordingly, a transceiver can identify when to transmit a paging signal to base transceiver 120 for assignment of bandwidth.

Once a transceiver is assigned bandwidth such as cycle 612, the new remote transceiver 116 can utilize diversity checks to support more robust communications  
10 as previously discussed in Fig. 10.

Fig. 12 is a timing diagram illustrating dynamic bandwidth allocation according to certain principles of the present invention. Upon detection of a fourth remote transceiver 116 transmitting paging signals, an available bandwidth can be reapportioned from that as shown in Fig. 11 to also include cycle 617 for supporting  
15 communication between remote transceiver #4 and base transceiver 120.

A paging message can be transmitted in cycle 1105 indicating that a remote transceiver desires allocation of bandwidth. Base transceiver 120 can then determine whether to allocate bandwidth to the link requesting transceiver.

Each remote transceiver 116 can be notified of an addition or deletion of a  
20 cycle in timing diagram 1200. The message can be broadcast from base transceiver 120 in cycle 1105 to all remote transceivers indicating that a new timing diagram will be implemented at the beginning of the next or following major cycle. Consequently, a newly added user can communicate with base transceiver 120 without interfering with other transceivers since a number of minor cycles in a major  
25 cycle is reapportioned to accommodate new or terminated transceivers. This technique ensures that bandwidth is optimally utilized by multiple transceivers.

Fig. 13 is a timing diagram of communications between a base transceiver and remote transceiver according to certain principles of the present invention. As shown, base transceiver 120 transmits and receives information to remote  
30 transceiver 116 during cycles 1305.

Between cycles 1305, a diversity check is performed. More specifically, two other transducers not presently used to support communications are activated in respective diversity slots 1320 and 1321 of a major cycle 1345 to determine whether orientation of a transceiver has changed substantially to warrant on which new axis  
5 the transceivers should transmit and receive.

Link qualities for communications between different combinations of transducers are compared in timing diagram 1300. Specifically, link qualities of communications in respective cycles 1305 and diversity slots 1320 and 1321 of a major cycle 1345 are compared. A selection of transducers for transmitting and  
10 receiving a data payload is derived as a result of comparing the link qualities.

Crossover point 1350 illustrates a condition when transducer z (as a result of changing orientation) provides a higher link quality than previously used transducer x. As a result, future data payload transmissions are supported on z-transducer 138 in following cycles 1310. Diversity checks of x-transducer 136 and y-transducer 137  
15 are thereafter performed in time slots 1323 and 1320, respectively, for major cycle 1365.

Fig. 14 is a block diagram of a communication system according to certain principles of the present invention. As shown, multiple transceivers communicate with each other over multiple inductive links 122.

20 More specifically, transceiver A can communicate with transceiver B and transceiver C over inductive links 122-AB and 122-AC, respectively. Similarly, other transceivers can communicate with each other over additional inductive links 122-BC and 122-BD. A communication code 470 is optionally used to support exclusive communications between transceivers.

25 As previously discussed, each transceiver can include one or multiple transducers so that the transceivers can communicate with each other regardless of their orientation with respect to each other. Also, more than one remote transceiver can be allocated a time slot for receiving data information. For example, a broadcast message can be transmitted to multiple transceivers simultaneously. This aspect of  
30 the present invention can be advantageous in audio systems where a single

transceiver broadcasts music to multiple headsets. This technique is also applicable to the topology illustrated in Fig. 3.

Fig. 15 is a timing diagram for supporting inductive communications among multiple transceivers according to certain principles of the present invention. As  
5 shown, different pairs of transceivers are allocated use of a particular communication cycle 1520 to communicate with each other. As previously discussed for Fig. 11, a minor cycle 1520 in a major cycle 1530 can be dedicated for paging signals and initialization of transceivers.

Each cycle 1520 allocated for use by a pair of transceivers for bidirectional  
10 communications can include a diversity check slot 1510. As previously discussed, diversity checks can be used to determine which of multiple potential axes is optimal to transmit or receive an inductive field. At a minimum, it can be determined which of multiple transducers is optimal for transmitting and receiving.

If a transceiver device includes multiple transducers, one or more of the  
15 multiple transducers can be selected to generate an inductive field on a particular axis. This adds another dimension to the number of potential axes on which a transceiver can transmit and receive. For example, both x-transducer 136 and y-transducer can be simultaneously activated to generate an inductive field on an axis between the two. This technique can be implemented in any application discussed in  
20 this specification. Consequently, an orientation of a transmitted or received inductive field is not limited to axes of the individual transducers in a transceiver.

Implementation of a diversity time slot can vary depending on the application. In the application as shown in Fig. 15, diversity check slot 1510 can be used to compare link qualities of different transducer links prior to bidirectional  
25 transmissions from a pair of transceivers in a given cycle 1520.

If both transceivers each include multiple transducers, a single transducer in one transceiver of the transceivers can be selected for transmitting and receiving. Each potential link between the selected transducer and other transducers at another transceiver can be tested using diversity checks to determine which combination  
30 provides a better link quality.

Fig. 16 is a block diagram of a communication system including multiple transceivers according to certain principles of the present invention. As shown, each transceiver device includes multiple transducer elements to receive and generate information over inductive field 122. Since each transceiver includes multiple  
5 transducers, a single transducer in one of the transceivers is selected to communicate with the other transceiver. In the instance shown, transducer x of transceiver A is selected for supporting communications.

In an application utilizing communication codes, a communication code 470 can include information identifying the single "selected" transducer in a transceiver  
10 if there an excess number of transducers in the transceiver device to communicate with other transceiver devices.

Fig. 17 is a timing diagram illustrating a diversity check according to certain principles of the present invention. To identify a preferred link for communications between transceivers, transceiver A transmits a coded signal from selected  
15 transducer x during cycle 1710.

During cycle 1710, transceiver B receives the signal transmitted from transceiver A and compares link qualities of the corresponding received signal on transducer x, y and z of transceiver B during respective time slots in timing diagram 1700. Transceiver B compares link qualities to determine which transducer receives  
20 a strongest signal.

A link comparison message 1730 is then generated by transceiver B and is transmitted from transceiver B to transceiver A indicating which transducer provides the best received signal quality. Consequently, future communications following a diversity check 1510 in cycle 1520 of Fig.15 can identify which axis to transmit and  
25 receive data information.

While this invention has been particularly shown and described with references to preferred embodiments thereof, it will be understood by those skilled in the art that various changes in form and details may be made therein without departing from the scope of the invention encompassed by the appended claims.

## CLAIMS

What is claimed is:

1. A method of communicating in an inductive communication system including multiple transceiver devices, the method comprising:
  - 5 establishing an exclusive communication relationship between the devices by:
    - at one of the devices, initiating an initialization process in which the devices communicate with each other;
    - from the strength of communication signals, assuring that the  
10 devices are in a close physical proximity which is closer than used for normal communications; and
    - establishing a communication code transferred between the devices; and
    - conducting normal communications between the devices using the  
15 communication code to maintain an exclusive communication relationship between the devices.
2. A method as in claim 1, wherein the initialization process is initiated by receipt of a message from a paging transceiver device.
3. A method as in claim 2, wherein the message from the paging transceiver  
20 device is initiated at least in part by sensing a predetermined condition caused by a user.
4. A method as in claim 1, wherein the initialization process is enabled at least in part based on a detected orientation of a transceiver device.
5. A method as in claim 1, wherein the communication code identifies a  
25 specific transceiver device and also identifies a type of transceiver device.

6. A method as in claim 1, wherein the communication code supports exclusive communications between a first transceiver device coupled to a cell phone and a second transceiver device coupled to a headset worn by a user.
7. A method as in claim 1 further comprising:
  - 5 storing a communication code at each of two communicating devices to support future exclusive communications between the two or more devices.
8. A method as in claim 1, wherein the initialization process is initiated by sensing whether a received signal is above a threshold.
- 10 9. A method as in claim 1, wherein the communication code is at least partially derived from a randomly generated number.
10. A method as in claim 1 further comprising:
  - sensing a position of the device as a part of the initialization process.
11. A method of communicating in an inductive communication system, the  
15 method comprising:
  - receiving a message from a transceiver device generating an inductive field;
  - based upon contents of the received message, determining whether the transceiver device has been programmed with a unique communication  
20 code that is used to support exclusive communications when communicating with at least one other transceiver device; and
  - if the transceiver device generating the inductive field has not been programmed with a unique communication code, establishing bidirectional communications with the transceiver device to program it with a unique  
25 communication code.

12. A method as in claim 11, wherein the step of determining whether the transceiver device has been programmed with a unique communication code includes detecting whether a valid communication code is received in a paging message generated by the transceiver device.
- 5
13. A method as in claim 11 further comprising:  
sensing that a predetermined condition has been met before programming the transceiver device with the communication code.
14. A method as in claim 13, wherein the condition is a predetermined protocol  
10 indicating a user's desire to initialize a remote transceiver device for further communications with a base transceiver device.
15. A method as in claim 11 further comprising:  
detecting that the transceiver device generating the inductive field is  
in closer proximity to a particular reference transceiver device than is  
15 necessary to support communications; and  
initializing the transceiver device with a unique communication code.
16. A method as in claim 15, wherein the transceiver device generating the  
inductive field is positioned at particular angular orientation relative to the  
reference transceiver device before it is programmed with a unique  
20 communication code.
17. A method as in claim 11 further comprising:  
transmitting messages from the transceiver device, the messages  
including the communication code to identify an origin of each message.
- 25 18. A method as in claim 11, wherein the communication code includes  
information identifying a type of the transceiver device generating an  
inductive field.

19. A method as in claim 11 further comprising:  
generating a communication code at a base transceiver that  
communicates with multiple remote transceiver devices; and  
transmitting the communication code from the base transceiver to  
5 program one of the remote transceiver devices with the communication code.
20. An inductive communication system including multiple transceiver devices,  
the system comprising:  
means for establishing an exclusive communication relationship  
between the devices by:  
10 at one of the devices, supplying means for initiating an  
initialization process in which the devices communicate with each  
other;  
from the strength of communication signals, sensing that the  
devices are in close physical proximity to communicate; and  
15 providing a means for establishing a communication code  
transferred between the devices; and  
means for conducting normal communications between the devices  
using the communication code to maintain an exclusive communication  
relationship between the devices.
- 20 21. An inductive communication system comprising:  
a first transceiver device that initiates communication by generating a  
communication signal over an inductive field;  
a second transceiver device that receives the communication signal  
and, based on a measured characteristic of the inductive field, the transceiver  
25 devices establishing a communication code that is to be transferred between  
the devices to maintain an exclusive communication relationship.

22. A system as in claim 21, wherein communication is initiated by receipt of a message from a paging transceiver device.
23. A system as in claim 22, wherein the message from the paging transceiver device is initiated at least in part by sensing a predetermined condition.
- 5 24. A system as in claim 21, wherein communication is initiated at least in part based on a detected orientation of the first transceiver device.
25. A system as in claim 21, wherein the communication code identifies a specific transceiver device and also identifies a type of transceiver device.
26. A system as in claim 21, wherein the communication code supports  
10 exclusive communications between the second transceiver device coupled to a cell phone and the first transceiver device coupled to a headset worn by a user.
27. A system as in claim 21 further comprising:  
a memory device in each transceiver to store a communication code  
15 identifying a relationship between the first and second transceiver devices.
28. A system as in claim 21, wherein establishing a communication code is initiated by sensing whether a received signal is above a threshold.
29. A system as in claim 21, wherein the communication code is at least partially derived from a randomly generated number.
- 20 30. A system as in claim 21 further comprising:  
multiple transducers in a transceiver device to sense its orientation before initiating communication and an initialization process to program a code.

31. A system as in claim 21, wherein the measured characteristic is a strength of the inductive field.
32. A method of supporting inductive communications among multiple transceivers, the method comprising:
- 5 sharing a wireless bandwidth to support bidirectional communications between pairs selected from at least three transceivers, a transceiver pair being assigned use of one or more time slots to communicate within a communication cycle;
- 10 disposing at least two transducer elements in at least one transceiver to support communications between the transceivers at any angular orientation relative to each other within a range of distance;
- for each pair of transceivers communicating with each other, comparing link qualities of communications between different transmit-
- 15 receive transducer element pairs of communicating transceivers; and
- selecting transmit-receive pairs of transducer elements to support further communications in respective time slots between pairs of transceivers based on detected link quality.
- 20 33. A method as in claim 32 further comprising:
- transmitting a signal from a single transceiver of the at least three transceivers; and
- simultaneously receiving the transmitted signal at each of multiple transceivers to determine link quality.
- 25 34. A method as in claim 32, wherein link qualities are compared by determining which of multiple transducer elements in a transceiver device receives a strongest signal from a transmitting transceiver.
35. A method as in claim 32 further comprising:

transmitting a message from at least one of the transceivers to indicate which of multiple transducer elements supports a strongest received signal at the remote transceiver.

36. A method as in claim 34, wherein the strongest signal is determined by  
5 comparing amplitudes of a received signal.
37. A method as in claim 32, wherein the at least three transceivers includes a base transceiver and at least two remote transceivers with which the base transceiver communicates.
38. A method as in claim 37, wherein the base transceiver includes multiple  
10 transducers and the remote transceivers each include a single transducer to support inductive communications.
39. A method as in claim 38 further comprising:  
generating a signal from a selected transducer in the base transceiver;  
and  
15 simultaneously receiving the signal on at least two remote transceivers to compare link qualities of different transducer element pairs.
40. A method as in claim 32 further comprising:  
allocating at least a portion of the shared wireless bandwidth to receive paging signals from other transceivers.
- 20 41. A method as in claim 40, wherein at least one of the other transceivers generating paging signals attempts to initiate an initialization process to establish a communication code for exclusive communications with a base transceiver.

42. A method as in claim 32, wherein a base transceiver includes one or more transducers and at least two remote transceivers each include two or more transducers at unique orientations with respect to each other to support communication with the base transceiver.
- 5 43. A system supporting inductive communications among multiple transceivers, the system comprising:
- at least three transceivers sharing a wireless bandwidth that supports bidirectional communications between pairs selected from the at least three transceivers, a transceiver pair being assigned use of one or more time slots
  - 10 to communicate within a communication cycle;
  - at least two transducer elements disposed in at least one transceiver to support communications between the transceivers at any angular orientation relative to each other within a range of distance;
  - a comparator to compare link qualities of communications between
  - 15 different transmit-receive transducer elements in transceivers communicating with each other; and
  - a controller to select which of multiple potential transmit-receive transducer elements is used to support further communications in respective time slots between pairs of transceivers based on detected link quality.
  - 20
44. A system as in claim 43, wherein a signal is transmitted from a single transceiver of the at least three transceivers and is simultaneously received at each of multiple transceivers to determine link quality.
45. A system as in claim 43, wherein the comparator determines which of
- 25 multiple transducer elements in a transceiver device receives a strongest signal from a transmitting transceiver.

46. A system as in claim 43, wherein a message is transmitted from at least one of the transceivers to indicate which of multiple transducer elements supports a strongest received signal at the remote transceiver.
47. A system as in claim 45, wherein the strongest signal is determined by  
5 comparing amplitudes of received signals.
48. A system as in claim 43, wherein the at least three transceivers includes a base transceiver and at least two remote transceivers with which the base transceiver communicates.
49. A system as in claim 48, wherein the base transceiver includes multiple  
10 transducers and the remote transceivers each include a single transducer to support inductive communications.
50. A system as in claim 49, wherein a signal is generated from a selected transducer in the base transceiver and is simultaneously received on at least two remote transceivers to compare link qualities of different transducer  
15 element pairs.
51. A system as in claim 43, wherein at least at least a portion of the shared wireless bandwidth is allocated for receiving paging signals from other transceivers.
52. A system as in claim 51, wherein at least one of the other transceivers  
20 generating paging signals attempts to initiate an initialization process to establish a communication code for exclusive communications with a base transceiver.
53. A system as in claim 43, wherein a base transceiver includes one or more transducers and at least two remote transceivers each include two or more

transducers at unique orientations with respect to each other to support communication with the base transceiver.

54. A system as in claim 43, wherein bi-directional communications between a pair of transceivers is supported by a selected pair of transmit-receive transducers, each transceiver of the pair of transceivers including one transducer of the transmit-receive pair of transducers.

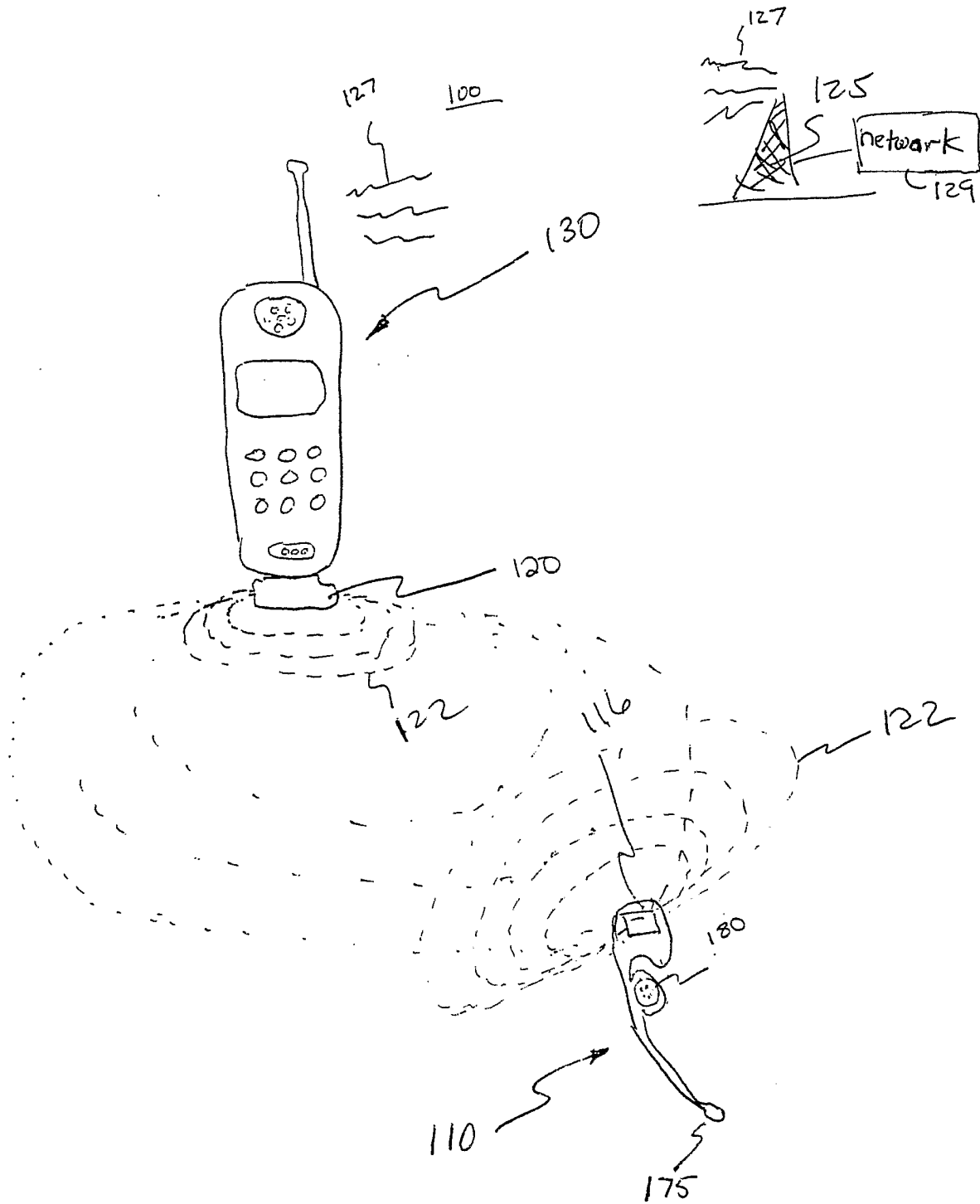

Fig. 1

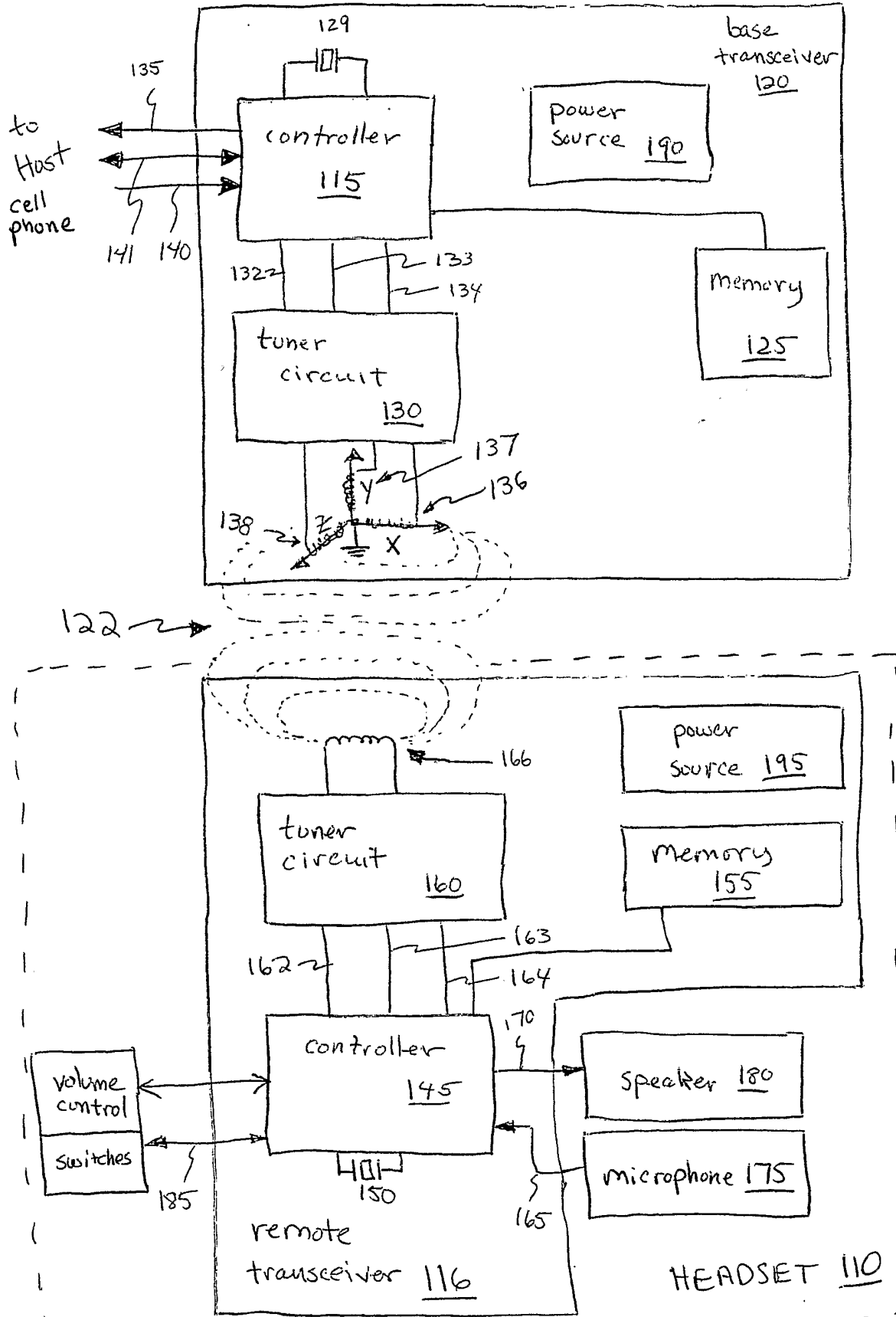

Fig. 2

3/17

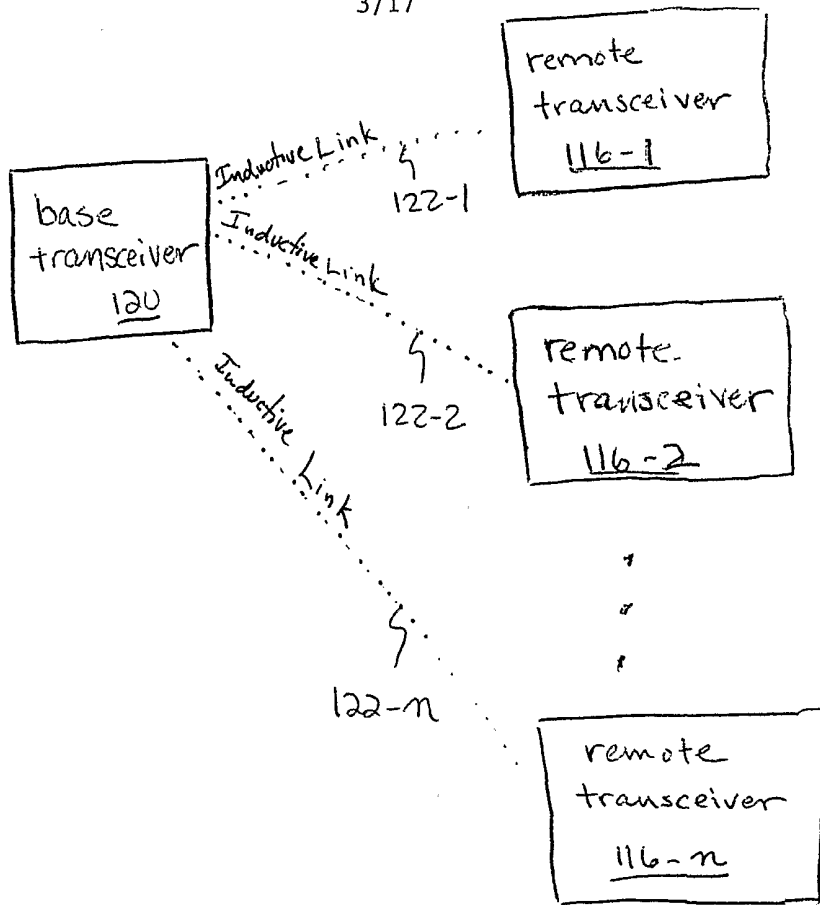

Fig. 3

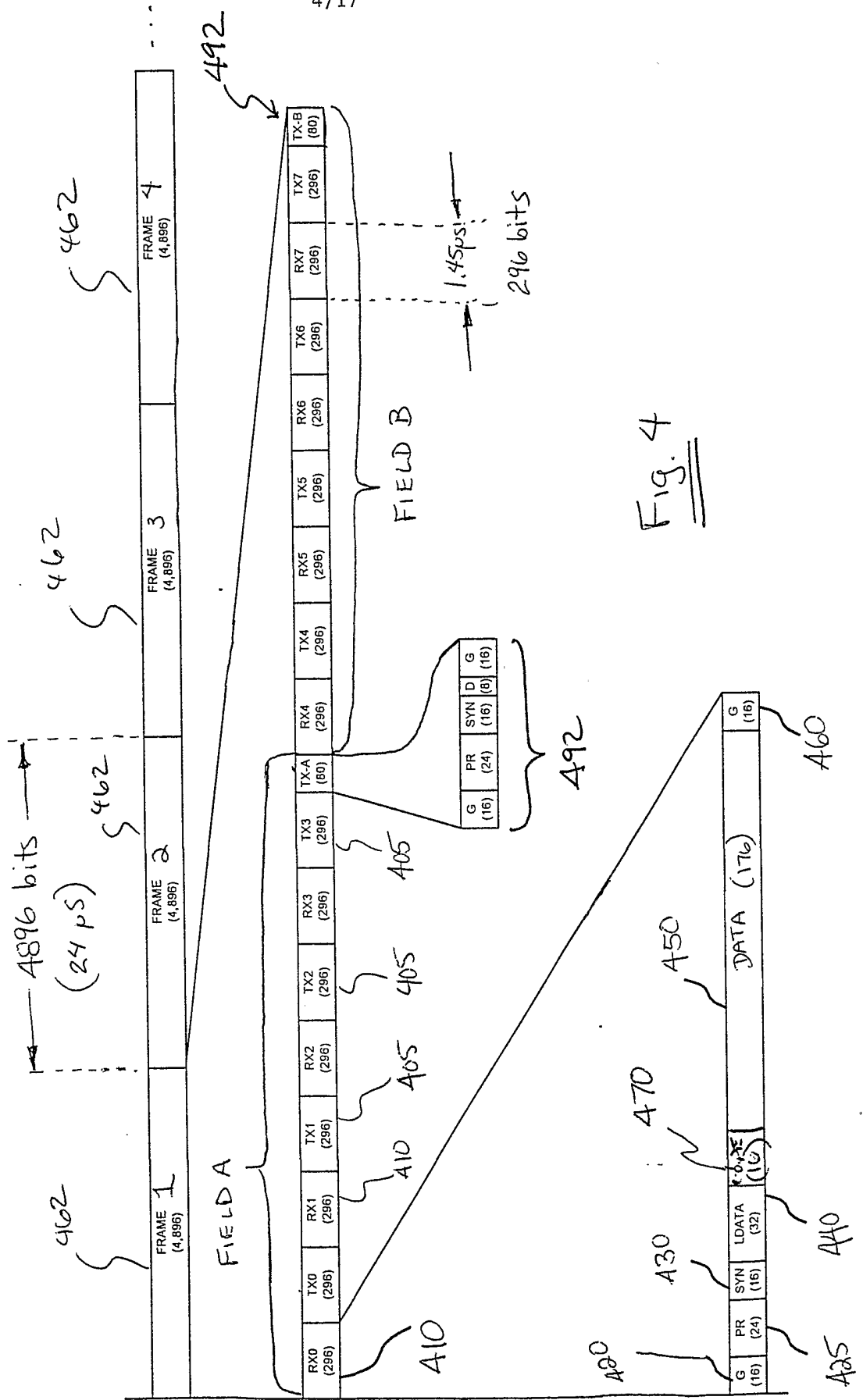

Fig. 4

5/17

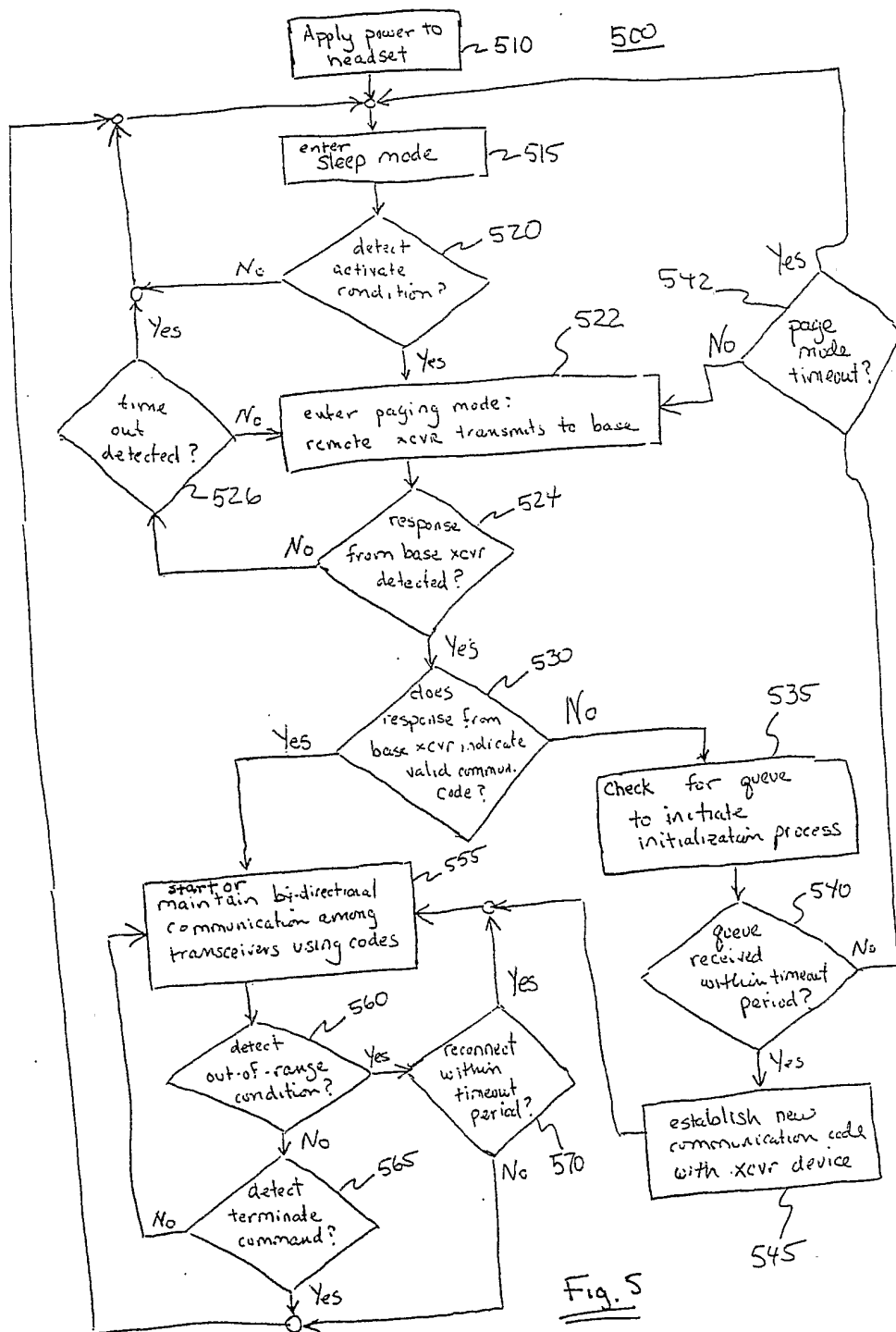

Fig. 5

6/17  
Initialization Method

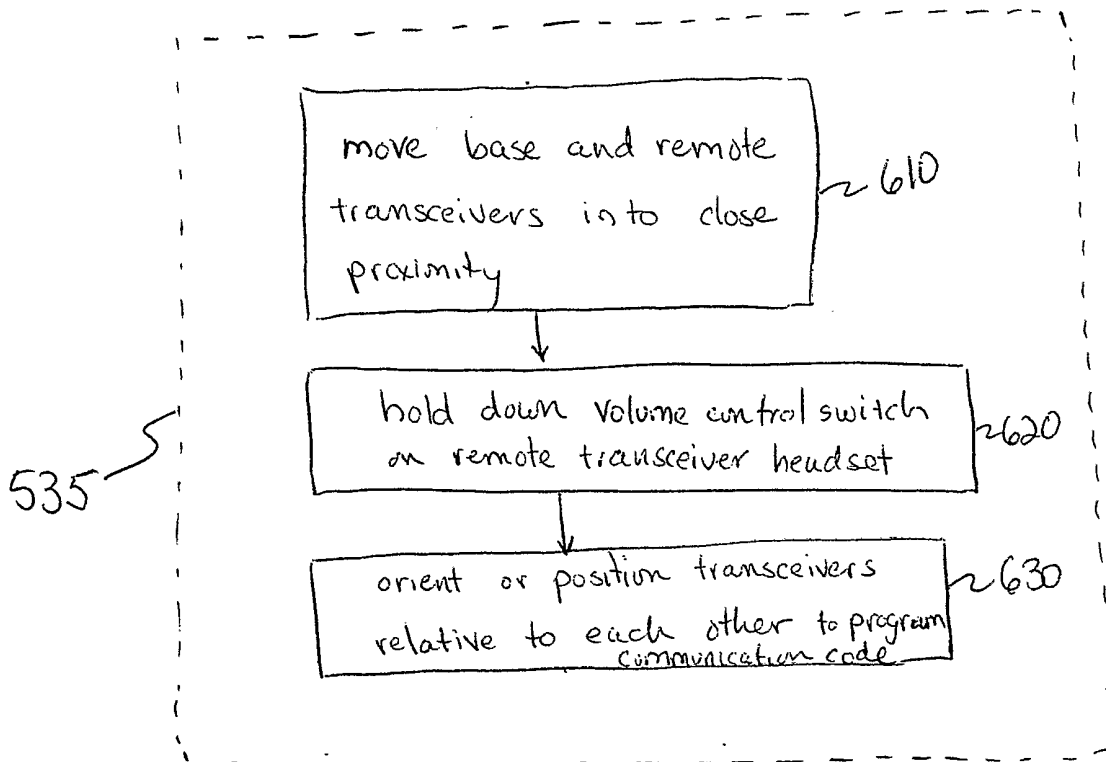

Fig. 6

BASE OPERATION

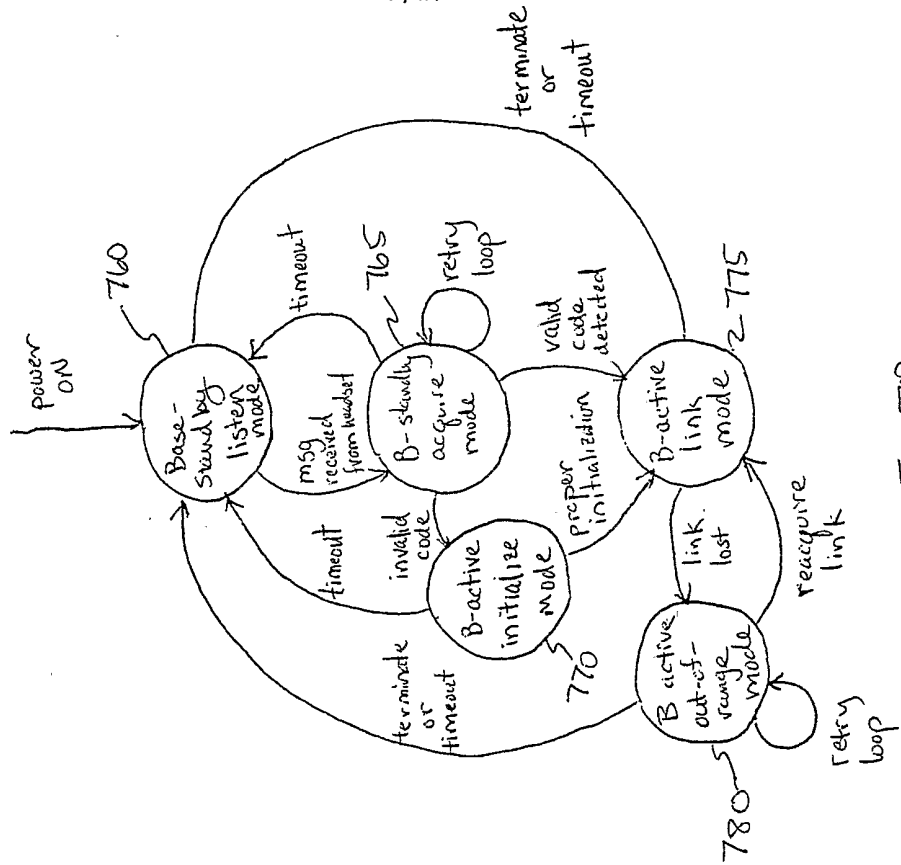

Fig. 7B

HEADSET OPERATION

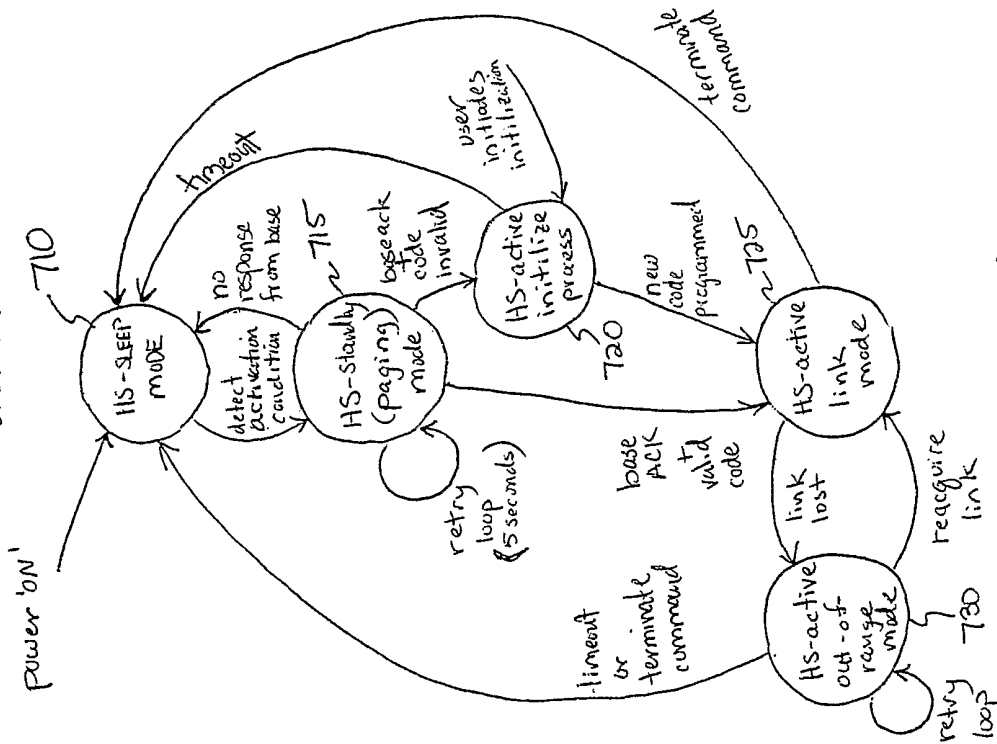

Fig. 7A

8/17

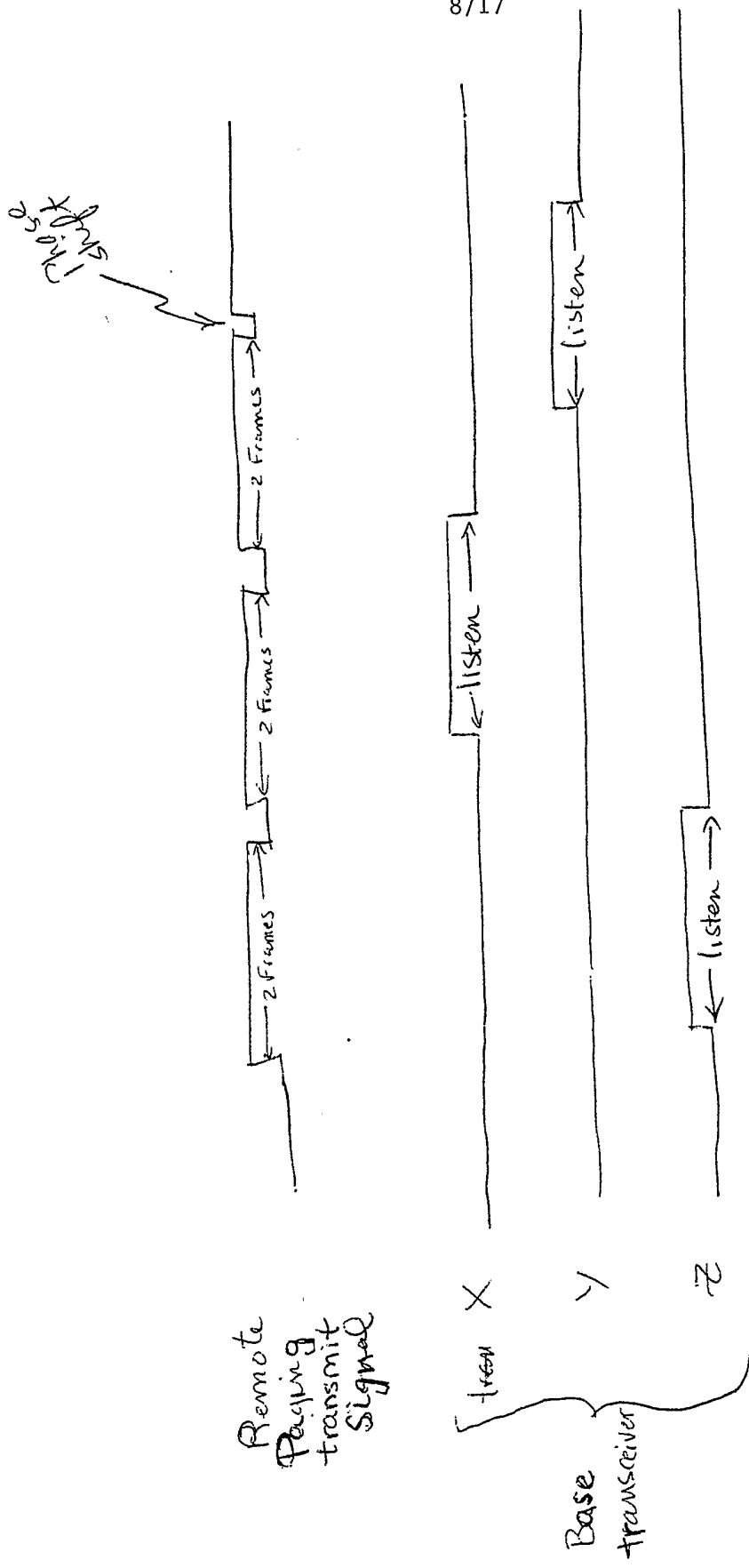

Fig. 8

9/17

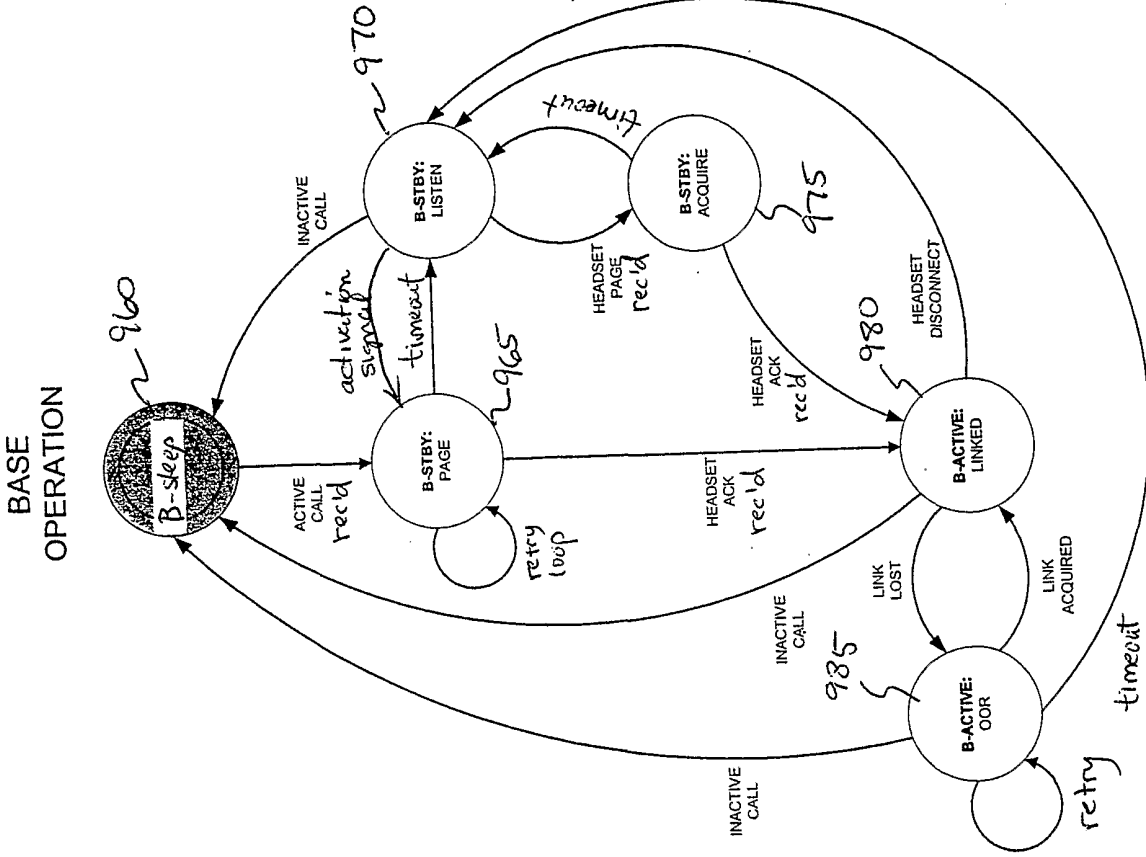

Fig. 9B

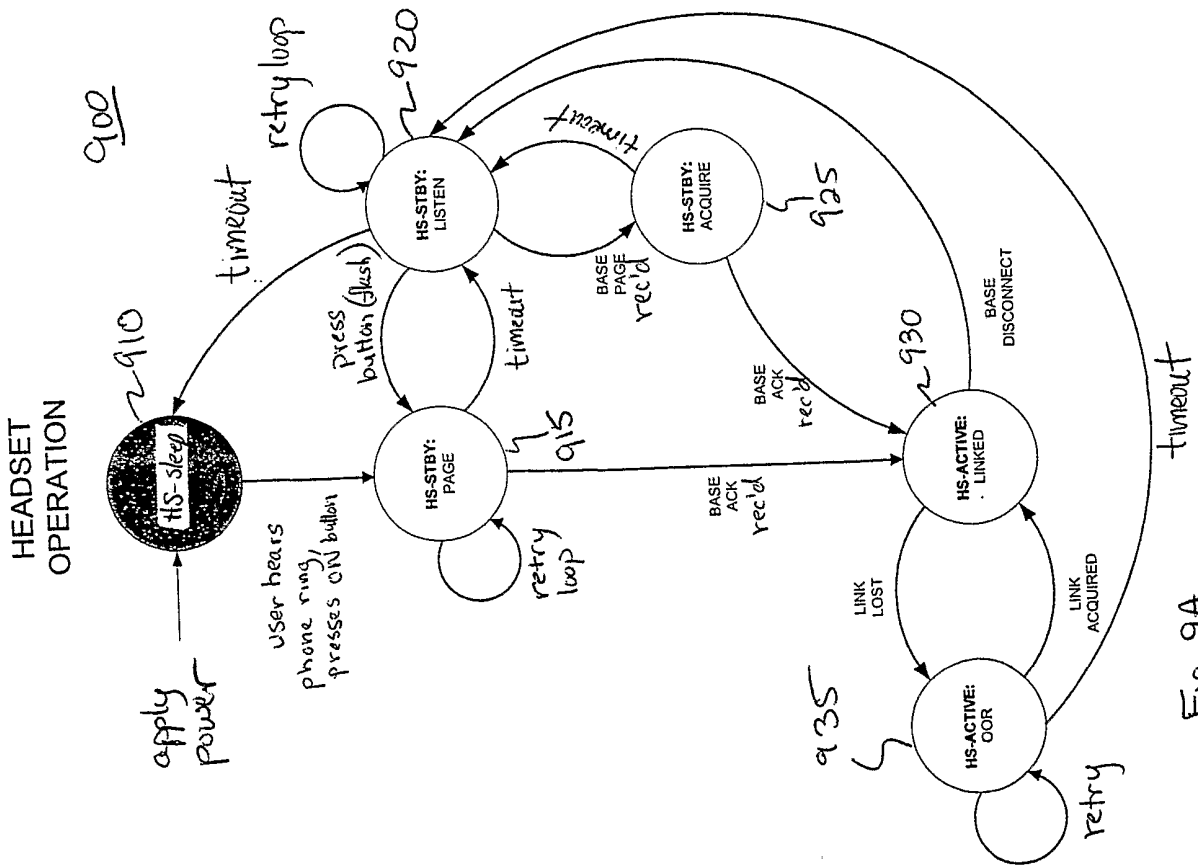
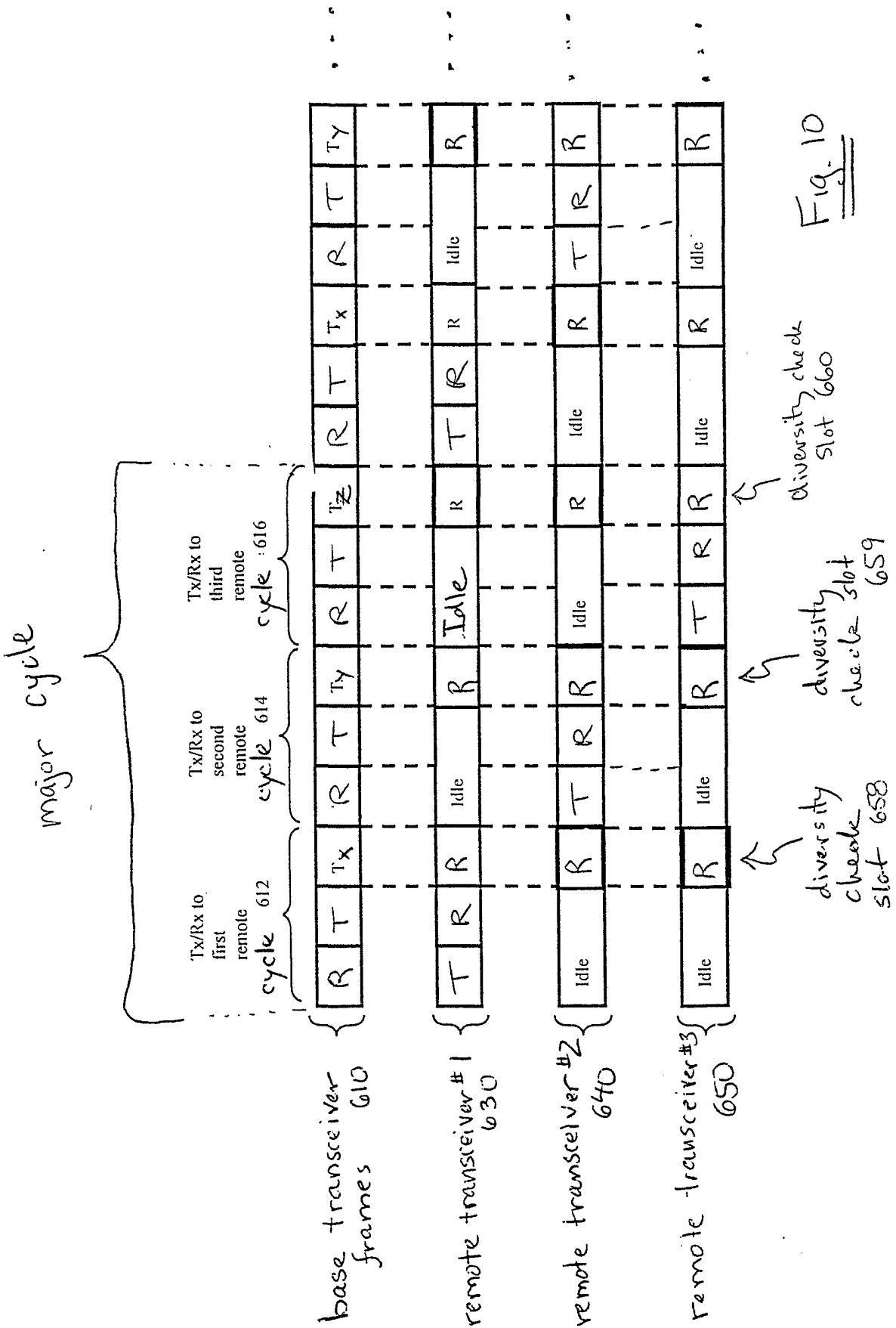
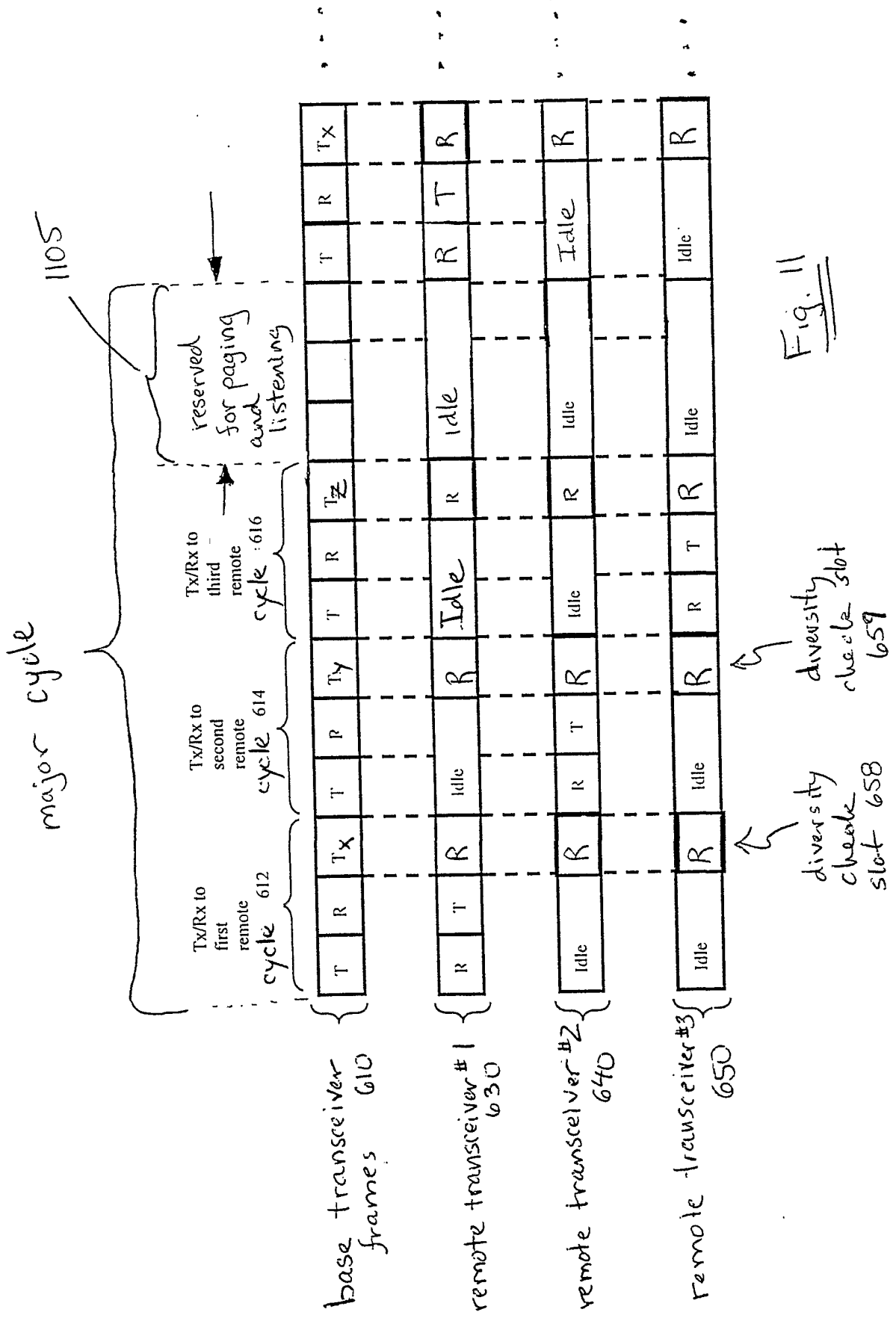

Fig. 9A





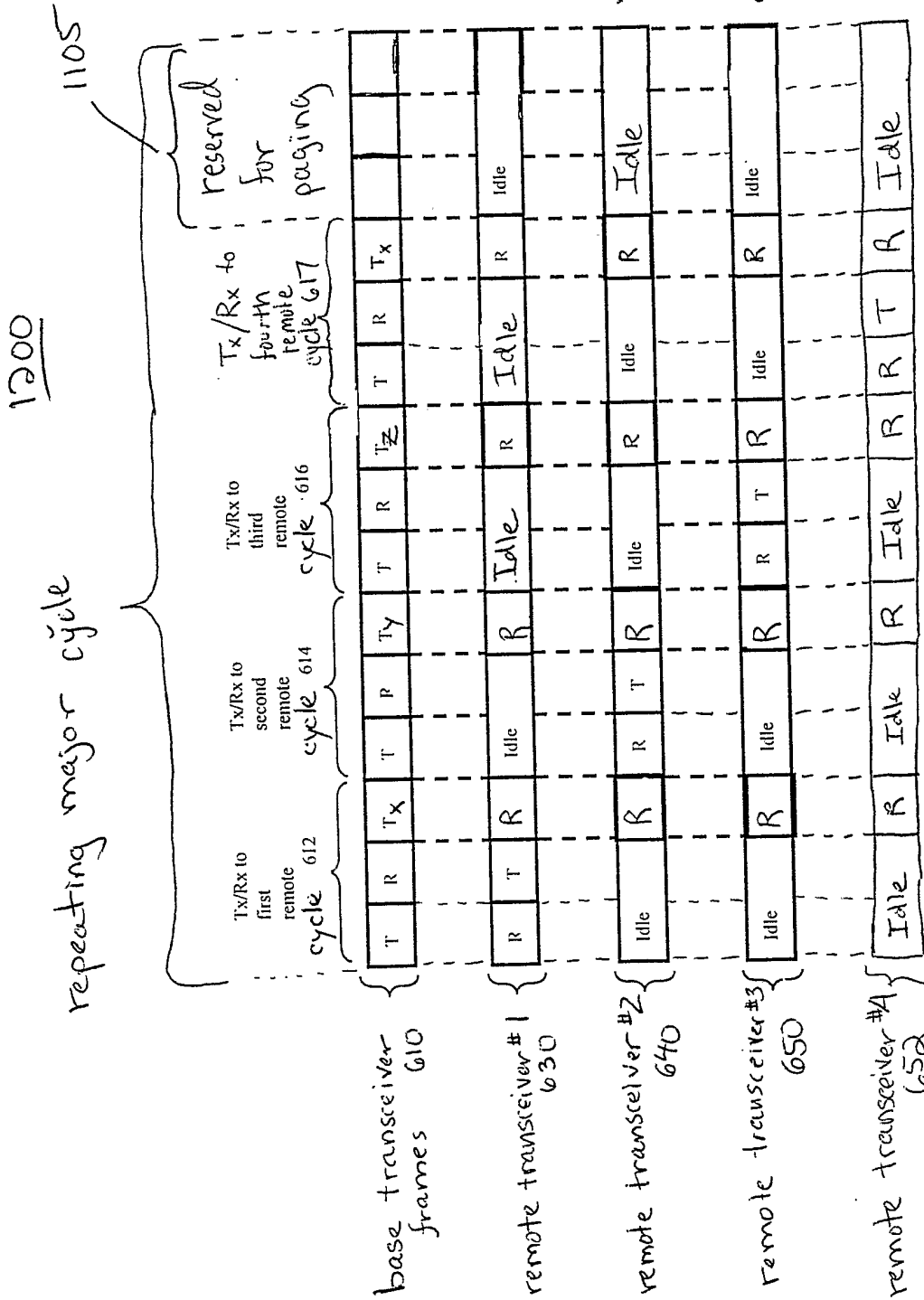
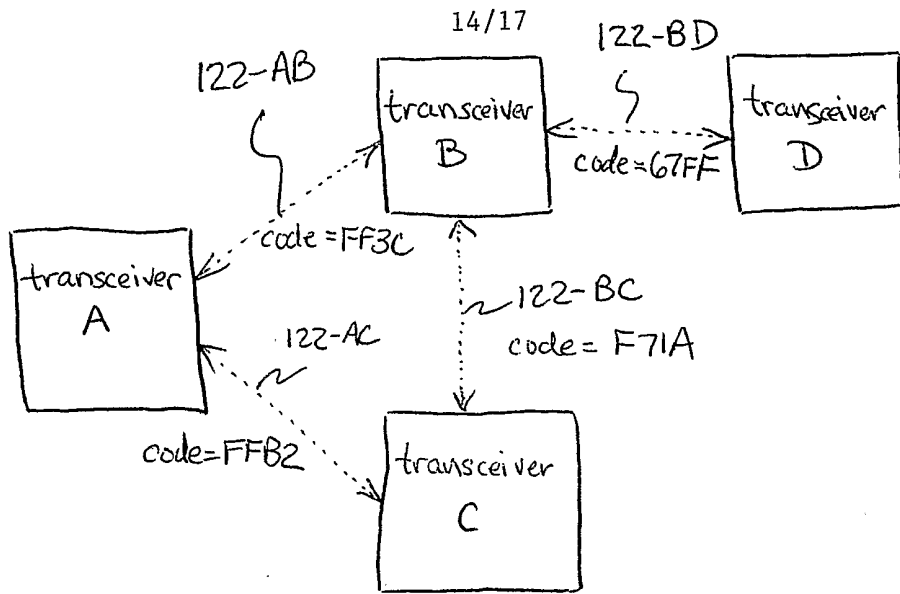

Fig. 12





1400

Fig. 14



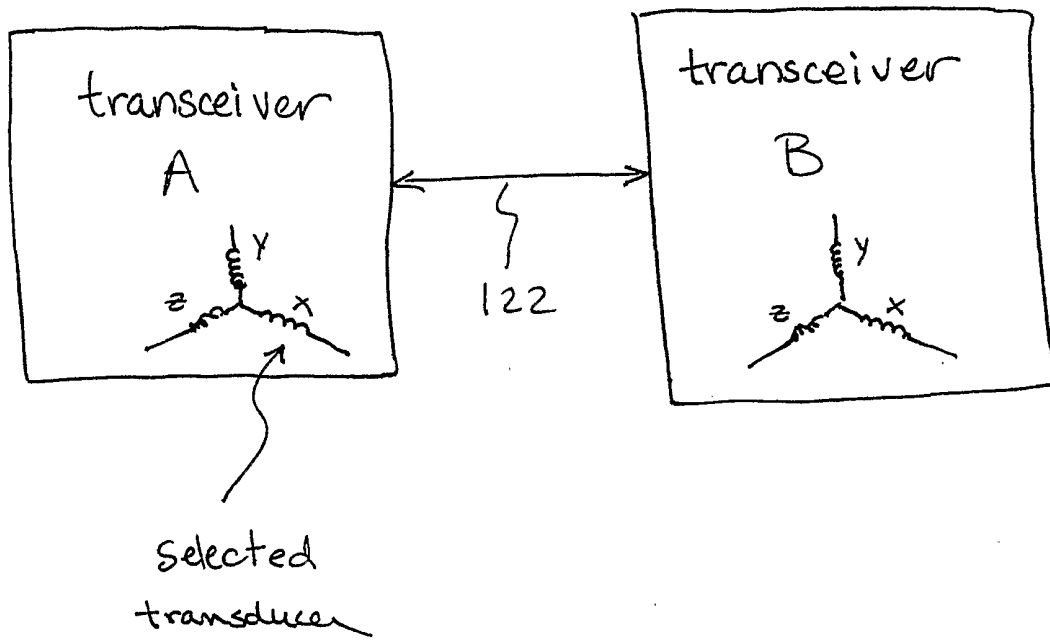

Fig. 16

1700

17/17

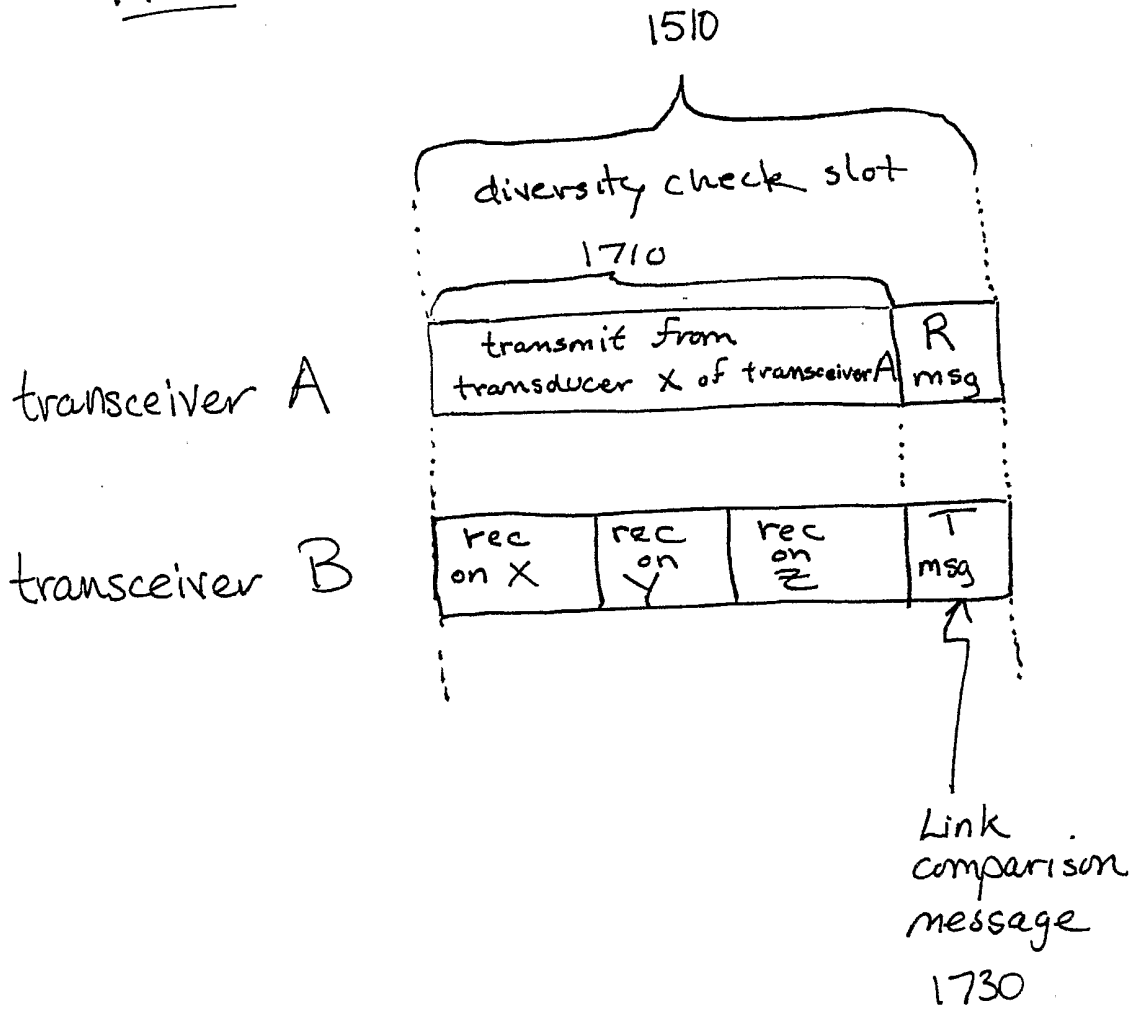

Fig. 17