

(No Model.)

T. S. MILLER.  
CABLEWAY.

2 Sheets—Sheet 1.

No. 523,364.

Patented July 24, 1894.

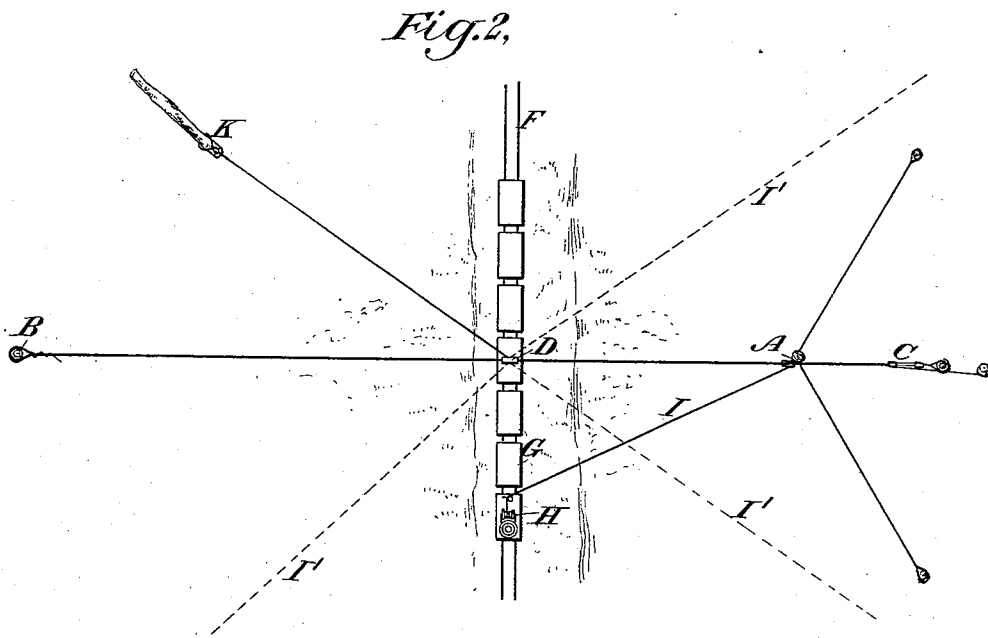
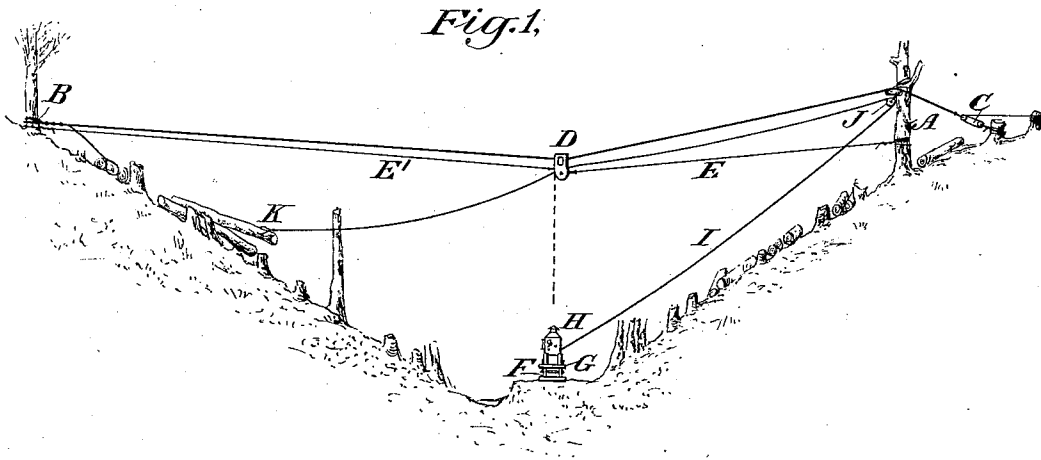

Witnesses:-

*D. H. Raymond*

*Fred Kimpfen*

Inventor:-

*Thomas S. Miller*

*By Gifford Saw*

*Attorney.*

T. S. MILLER.  
CABLEWAY.

No. 523,364.

Patented July 24, 1894.

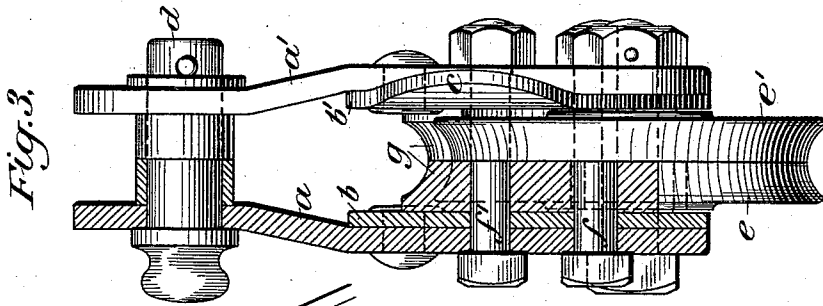

Fig. 3.

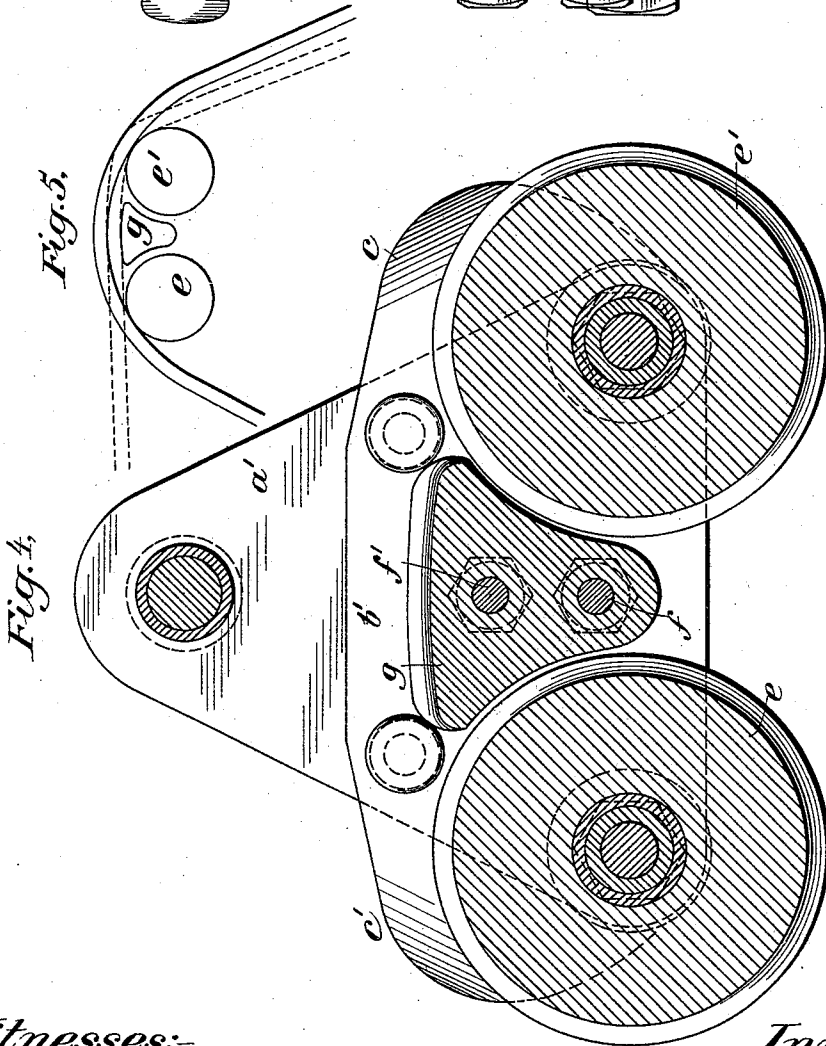

Fig. 4.

Fig. 5.

Witnesses:-  
*D. H. Hayward*  
*Fred Kemper*

Inventor:  
*Thomas S. Miller*  
 by *Gifford & Sawyer*  
 Attorneys.

# UNITED STATES PATENT OFFICE.

THOMAS SPENCER MILLER, OF SOUTH ORANGE, NEW JERSEY.

## CABLEWAY.

SPECIFICATION forming part of Letters Patent No. 523,364, dated July 24, 1894.

Application filed April 17, 1894. Serial No. 507,889. (No model.)

*To all whom it may concern:*

Be it known that I, THOMAS SPENCER MILLER, a citizen of the United States, and a resident of South Orange, in the State of New Jersey, have invented certain new and useful Improvements in Cableways, of which the following is a specification.

I have, in the accompanying drawings, represented my present invention as applied to a cableway used for log skidding but I do not wish to be understood as limiting myself to a cableway of that character unless so specified.

Figures 1 and 2 are an elevation and plan of a skidding apparatus in position for use. Figs. 3 and 4 are an end and side view each partly in section of the cable support. Fig. 5 is a diagram to illustrate the mode of operation of the cable support.

I will first describe the cable support shown in Figs. 3, 4 and 5.

Heretofore, in skidding apparatuses it has been customary to support the cable upon an ordinary sheave block; the sheave being considered essential to enable the workmen to pull the cable on this support when placing it in position. But when the cable was drawn taut, its support upon the surface of the sheave caused an abrupt turn which, together with the backward and forward movement of the surface of the sheave, impaired the durability of the cable. In other cableways, stationary saddles have been employed to increase the durability of the cable; but these are objectionable in cases where the cable is to be frequently erected and taken down, as in skidding apparatus, by reason of the difficulty in pulling the cable when slack endwise over its support.

My cable support is designed to combine the advantages of both of the above supports; and it consists in interposing between two sheaves, a saddle which is so placed as that the cable rests upon it when taut, but clears it when slack.

The block contains two side plates  $a$  and  $a'$ , each of which is reinforced by a plate  $b$ ,  $b'$ . Each plate  $b$ ,  $b'$  contains a flange  $c$  extending forward and a corresponding flange  $c'$  extending backward; the flanges on the opposite plates  $b$ ,  $b'$  diverging from each other, as shown.

$d$  is the ordinary pin connecting the two

side plates and serving as a means of attachment for the chain by which the whole is supported.  $e$  and  $e'$  are two sheaves mounted at the same level with each other in the block. Intermediate these two sheaves and fixed between the plates of the block by the bolts  $f$ ,  $f'$ , is the saddle  $g$ , the upper surface of which is grooved to correspond with the grooved peripheries of the sheaves and is curved fore and aft in the form shown.

Cables are usually made of wire rope and possess stiffness to a large degree so that when a cable is laid across the sheaves  $e$  and  $e'$  in the position indicated in Fig. 5 where it hangs downwardly on each side of those sheaves, the stiffness of the cable causes it, while slack, to raise up between the sheaves in the position shown in full lines in Fig. 5 so as to entirely clear the surface of the saddle  $g$ . Under these circumstances, the cable can obviously be run backward or forward upon the sheaves  $e$  and  $e'$  with fully as much, if not more, ease as upon a single sheave, being entirely unimpeded by any frictional contact with the saddle. When, now, the cable is placed in working position and drawn taut, and especially when its tautness is increased by carrying a load in use, it will approximate to the position shown in dotted lines in Fig. 5, wherein it rests in contact with the surface of the saddle  $g$  as well as with the sheaves. This contact with the saddle affords the friction to oppose the backward and forward working of the cable upon its support in use and also affords a support between the two sheaves which, by being elevated slightly above their upper level, as shown in Figs. 3 and 4, slightly raises the cable at that point when taut and reduces the abruptness of the turn of the cable at its point of contact with either of the sheaves.

Having constructed the cable support in the above manner, it is secured to a tree at A (Figs. 1 and 2) by an ordinary chain; the cable is then run through it and after attaching the far end of the cable, as at B, it is drawn taut by the tackle C. Upon the cable is mounted a sheave-block D which is secured in position by the stationary ropes E, E'.

F is a railway track and G a train of cars being loaded with logs. Upon one car of this train is mounted a rope-drum engine H which

operates the fall rope I extending over a sheave J and over the sheave of the sheave-block D.

In Figs. 1 and 2 of the drawings, the railway track is shown as located in a gulley across which the cable extends above the cars and the sheave-block D is fixed directly above the train of cars and in such position that the tongs K upon the end of the fall rope can reach logs in various directions, shown by the position of the tongs K in Fig. 2, and by the dotted lines I'.

I claim—

1. In a cableway in combination with the cable which constitutes the track, two supports whereby the cable is supported when not stretched and a saddle located between said supports below the upwardly curved surface of the unstretched cable as it rests upon

the said two supports and in position to be touched by the cable when stretched by the straightening of the cable, substantially as described.

2. A cable support consisting of a sheave block containing two sheaves *e, e'* and the interposed saddle *g* having its bearing surface elevated somewhat above the level of the sheaves; said sheaves and said saddle being mounted in substantially the same plane, substantially as described.

Signed at New York, in the county of New York and State of New York, this 5th day of April, A. D. 1894.

THOS. SPENCER MILLER.

Witnesses:

D. HOWARD HAYWOOD,  
J. S. FOSTER.