

April 19, 1966

A. E. WINSLOW

3,246,856

SUPPORTING CORE STRUCTURE FOR YARN PACKAGES

Filed July 18, 1963

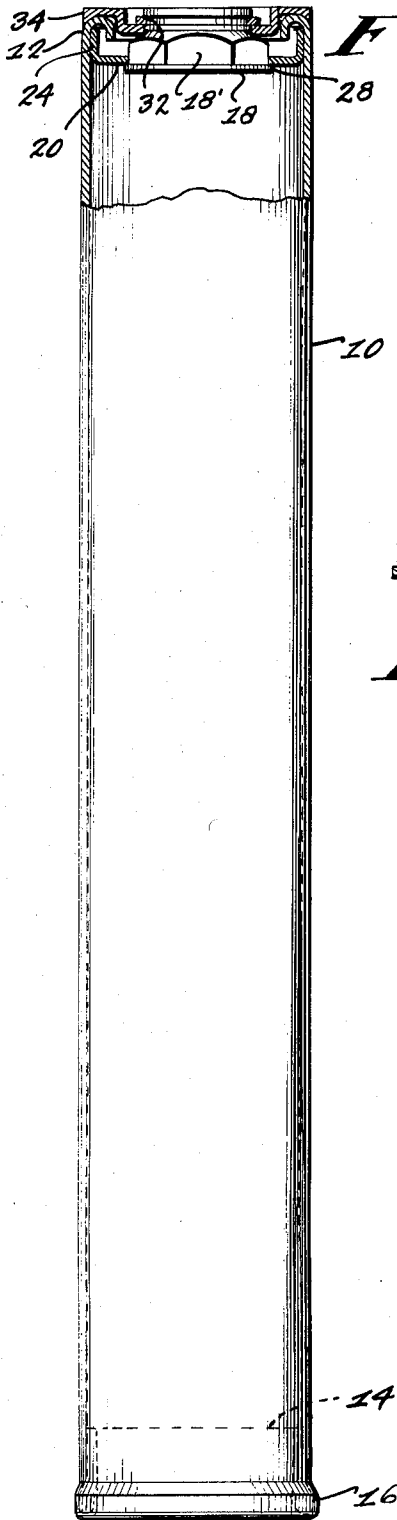

Fig. 1

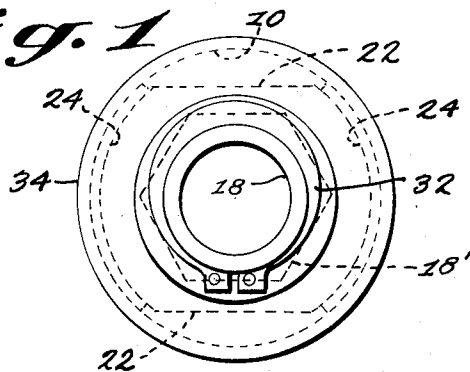

Fig. 2

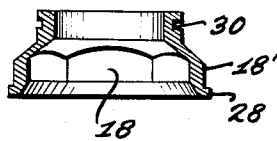

Fig. 3

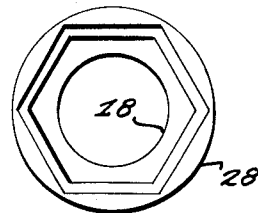

Fig. 4

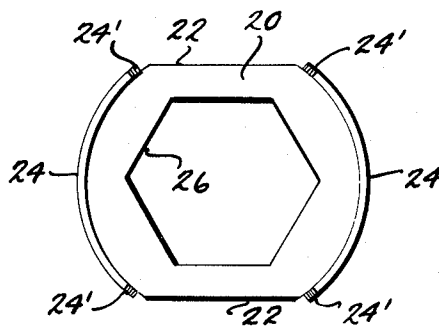

Fig. 5

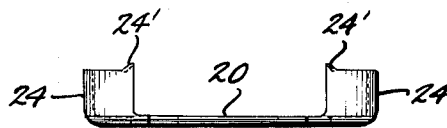

Fig. 6

INVENTOR.

ALBERT E. WINSLOW

BY

Channing L. Richards &
Dalbert H. Sheft
ATTORNEYS

1

2

3,246,856

SUPPORTING CORE STRUCTURE FOR YARN PACKAGES

Albert E. Winslow, Greenville, S.C., assignor to Winslow, Incorporated, a corporation of South Carolina
 Filed July 18, 1963, Ser. No. 295,912
 7 Claims. (Cl. 242—46.21)

This invention relates to core structures of the type used by the textile industry for supporting yarn packages of various sorts, and more particularly to a core structure of this type that is uniquely equipped for spindle mounting.

A core structure such as is provided according to the present invention is especially well suited for arrangement as a top drive roving bobbin, and the invention is accordingly described at further length in relation to a representative roving bobbin embodiment equipped for top driving as illustrated in the accompanying drawings, in which:

FIG. 1 is a side elevation of the bobbin structure with a portion of the barrel member broken away and sectioned to show the top drive fitting assembly;

FIG. 2 is an enlarged top plan view corresponding to FIG. 1;

FIG. 3 is a central vertical section of the top drive bushing member;

FIG. 4 is a bottom plan view corresponding to FIG. 3;

FIG. 5 is a top plan view of the plate member provided for positioning the bushing member; and

FIG. 6 is a side elevation as seen from the bottom of FIG. 5.

The roving bobbin structure shown in FIG. 1 comprises a tubular barrel member 10 having its lower end arranged for positioning at a whorl or enlarged base portion of a spindle (not shown), and having its upper end formed reentrantly as at 12. The barrel member 10 may be constructed of any material that will present a satisfactory yarn winding surface and that will allow formation of the reentrant upper end 12. Suitably, a convolutely wound paper tube is used, in which case the lower barrel member end is preferably fitted with an inner thickening collar, as indicated at 14, and protected by an annular metal ferrule 16 crimped in place thereat.

The top drive for the illustrated bobbin structure is provided through a spindle bushing 18 that is positioned by an arcuately flanged plate member 20 installed within the barrel member 10 with its arcuate flanging extending within the reentrant end portion 12. The form of the plate member 20 is illustrated particularly in FIGS. 5 and 6, in which it is seen to have a segmented circular shape characterized by opposite side portions 22 that are straight and parallel at a widthwise spacing that is sufficiently less than the inner diameter of the reentrant end portion 12 to allow insertion of the plate member 20 therethrough for installation; the plate member 20 being inserted through the reentrant end portion 12 with its plate portion disposed axially of the barrel member 10 and then shifted to a transverse position for installation.

The arcuate plate member flanging 24 is formed in opposite portions between the straight side portions 22 at a diameter fitting the internal diameter of the barrel member 10 and acts to engage the barrel member within the reentrant end portion 12 so as to fix the installed plate member 20 against turning therein. In the illustrated embodiment, the engaging action is specially provided for by a barbed arrangement at the extending edge of the arcuate flanging that suitably takes the form of pointed projections 24' at each end of each flange portion 24.

For positioning the spindle bushing 18, the plate member 20 is additionally formed with a central aperture 26 in which the bushing 18 is held against relative turning as

well as being positioned axially of the barrel member 10. Because the illustrated spindle bushing 18 is formed interiorly (see FIGS. 3 and 4) for fitting a hexagonal spindle tip portion (not shown), it has a corresponding shape exteriorly adjacent its lower end, as at 18', and the central plate member aperture 26 has a mating hexagonal shape; although it will be apparent that the same purpose could be accomplished by any shaping of the aperture 26 that would lock or key a particular bushing 18 therein against turning.

At its lower end (i.e., the end positioned remotely with respect to the reentrant barrel member end portion 12), the bushing 18 is formed with an exterior flange 28 that is seated against the side of the plate member 20 facing away from the reentrant end portion 12, so that the body of the bushing 18 extends through the central plate member aperture 26 and projects outwardly through the reentrant end portion 12 in centrally spaced relation.

Adjacent its projecting end, the bushing 18 is circumferentially grooved, as at 30 in FIG. 3, to receive a snapping element 32 for securing it at a centrally apertured retainer member 34 that is disposed in covering relation at the reentrant end portion 12. By such an arrangement, the retainer member 34 is made to serve as an assembly anchor by which the bushing 18 is fixed rigidly in place after causing the arcuate plate member flange portions 24 to be pressed firmly in place within the reentrant end portion 12 to engage the barrel member 10 against relative turning. Instead of the snap-ring element 32 any other suitable securing means might alternatively be used, or the retainer member 34 and bushing 18 might be respectively formed for direct assembly engagement, as by forming the bushing 18 of a sufficiently flexible plastic material to provide an assembly seat at which the centrally apertured retainer member 34 might be snapped securely in place without requiring any separate securing means.

Additionally, the covering disposition of the retainer member 34 at the reentrant barrel member end portion 12 makes it possible to form spool structures readily according to the present invention as well as bobbin structures of the type illustrated. To form a spool structure, it is only necessary to increase the outer diameter size of the retainer member 34 to the flange size desired. Either single or double flanged spools may be formed in this manner; it being understood that the barrel member 10 would be formed reentrantly at both ends if a double flanged spool is to be provided, that its opposite end would probably have to be fitted differently if a single flanged spool structure were desired, and that the bushing 18 would likely require a different interior formation for spool spindle mounting.

This invention has been described in detail above for purposes of illustration only and is not intended to be limited by this description or otherwise except as defined by the appended claims.

I claim:

1. A supporting core structure for yarn packages, said core structure comprising a tubular barrel member having at least one reentrant end portion, an arcuately flanged plate member installed within said barrel member with the arcuate flanging thereof being arranged as an opposed pair of arcuate segments each having a chord of less extent than the inner diameter of said reentrant end portion and extending within said reentrant end portion, said arcuate flanging engaging said barrel member within said end portion for fixing the installed plate member against turning with respect to said barrel member, and spindle engaging means positioned by said plate member and held thereby against relative turning.

2. A supporting core structure for yarn packages, said core structure comprising a tubular barrel member having

3

at least one reentrant end portion, an arcuately flanged plate member installed within said barrel member and having a segmented circular shape characterized by opposite side portions that are straight and parallel at a widthwise spacing less than the inner diameter of said reentrant end portion, the arcuate flanging of said plate member extending within said reentrant end portion and engaging said barrel member thereat for fixing the installed plate member against turning with respect to said barrel member, and spindle engaging means positioned by said plate member and held thereby against relative turning.

3. A supporting core structure as defined in claim 2 and further characterized in that the extending edge of said arcuate flanging is barbed for engaging said barrel member within said reentrant end portion.

4. A supporting core structure as defined in claim 3 and further characterized in that the arcuate flanging of said plate member is formed in opposite portions between said straight side portions at a diameter fitting the internal diameter of said barrel member and the barbed extending edge of said flanging is formed by pointed projections at each end of said opposite flange portions.

5. A supporting core structure as defined in claim 2 and further characterized in that said spindle engaging means is formed by a bushing member positioned within a cen-

4

tral aperture of said plate member and is held against relative turning by mated polygonal shaping of said plate member aperture and bushing member.

6. A supporting core structure as defined in claim 5 and further characterized in that said bushing member is exteriorly flanged at one end and seated thereat against the side of said plate member facing away from said reentrant end portion with the bushing member body extending through said plate member aperture and projecting outwardly through said reentrant end portion in centrally spaced relation, and in that a centrally apertured retainer member is disposed in covering relation at said reentrant end portion with the projecting end portion of said bushing member received by the central aperture thereof and secured thereat.

7. A supporting core structure as defined in claim 6 and further characterized in that said barrel member has only one reentrant end portion and the bushing member positioned thereat is formed to equip said core structure for service as a top drive roving bobbin.

References Cited by the Examiner

UNITED STATES PATENTS

2,953,317 9/1960 Atwood et al. ----- 242-118.31

MERVIN STEIN, *Primary Examiner.*