

(No Model.)

3 Sheets—Sheet 1.

J. ZERFAS.
FRAME FOR DOOR AWNINGS.

No. 522,817.

Patented July 10, 1894.

Fig: 1.

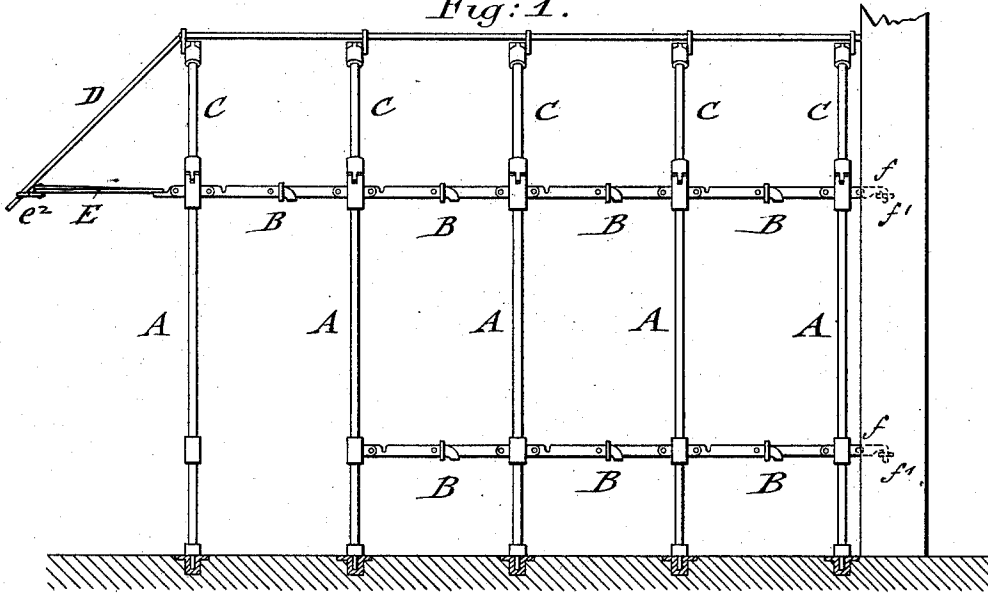

Fig: 2.

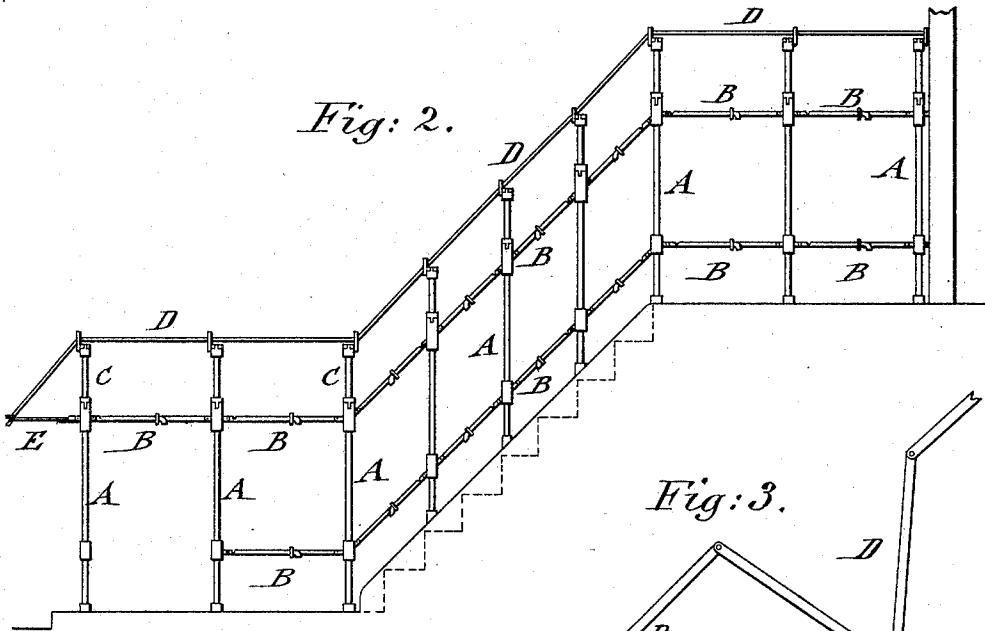
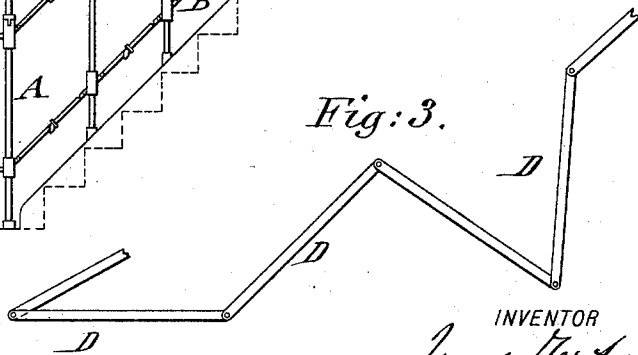

Fig: 3.



WITNESSES:

J. Musblatky
H. P. Brennan

INVENTOR

Joseph Zerfas
BY *Joseph Paegauer*
ATTORNEYS.

J. ZERFAS.
FRAME FOR DOOR AWNINGS.

No. 522,817.

Patented July 10, 1894.

Fig: 10.

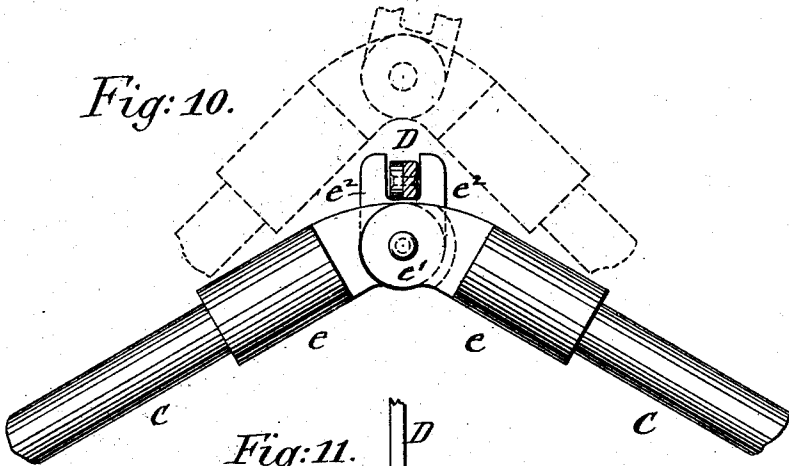

Fig: 11.

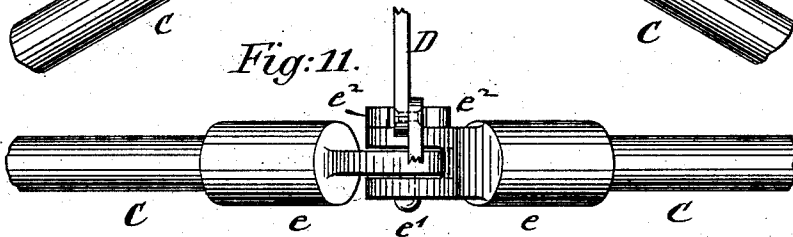
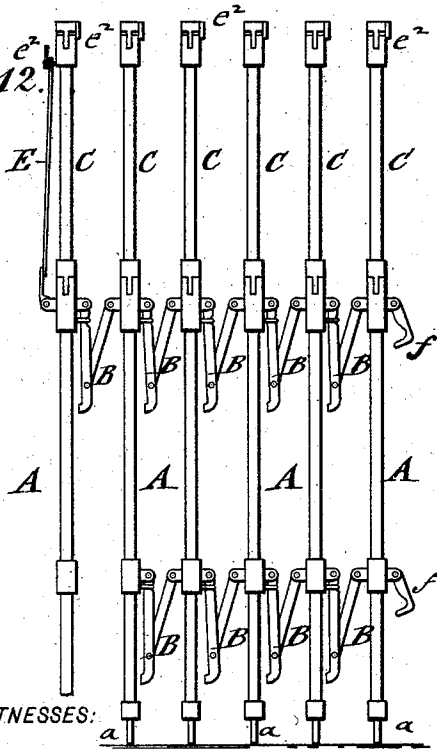

Fig: 12.



WITNESSES:

J. Nussblatky
H. R. Brennan

Fig: 13.

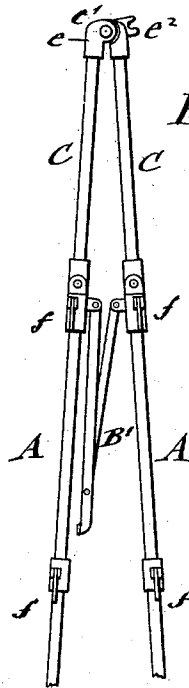

INVENTOR

Joseph Zerfas
BY
George & Paegauer
ATTORNEYS.

UNITED STATES PATENT OFFICE.

JOSEPH ZERFAS, OF NEW YORK, N. Y.

FRAME FOR DOOR-AWNINGS.

SPECIFICATION forming part of Letters Patent No. 522,817, dated July 10, 1894.

Application filed April 14, 1894. Serial No. 507,522. (No model.)

To all whom it may concern:

Be it known that I, JOSEPH ZERFAS, a citizen of the United States, residing in the city, county and State of New York, have invented certain new and useful Improvements in Frames for Door-Awnings, of which the following is a specification.

The supporting-frames for door-awnings, used in front of the doors of residences, restaurants, hotels, &c., are formed of a number of upright posts which are set into sockets of the floor and connected with each other by means of horizontal braces that are screwed into suitable nipples on the uprights, the whole structure being attached to the door-jamb and removed when the awning is not required for use. The use of these door-awnings is connected with many objections, such as, the loss of some of the parts, the injuring of the screw-threads on the ends of the braces, which renders the putting up of the frame difficult, the unsightliness of the entire frame and awning when disconnected and bundled up, and the considerable loss of time required for putting up or taking down the awning.

The object of my invention is to overcome the objections to the present door-awnings and furnish an improved frame for the same, which can be readily folded together both in a longitudinal and lateral direction, so that all the parts remain in connected position whether they are folded up or in position for use and that the supporting-frame is thereby ready at any moment to be put up, as none of the parts can become detached and injured or lost.

The invention consists of a frame for door-awnings which is composed of two sets of uprights each of which is connected by pivoted and folding side-braces at their upper and lower ends, inclined top-pieces which are pivoted to the upper ends of opposite uprights and to each other, the pivots of the top-pieces being provided with recessed lugs for receiving a longitudinal folding rod for supporting the top of the awning, transverse braces connecting the upper ends of opposite uprights so as to stiffen them in lateral direction, means for locking the side and transverse braces when they are in extended position, an angular end-frame that is hinged to the upper ends of the outermost uprights, so as to be

thrown into horizontal position or folded up with the inclined top-pieces, and hooks pivoted to the innermost uprights and adapted to be inserted into eyes secured into the jambs of the door, while the lower pin-shaped ends of the uprights are retained in stationary sockets on the pavement, steps or other point where the door-awning is to be put up.

The invention consists further of certain details of construction, which will be fully described hereinafter and finally pointed out in the claims.

In the accompanying drawings, Figures 1 and 2 represent side-elevations of my improved frame for door-awnings, showing it respectively in use with a door or level with the street, and with a door above the level of the street. Fig. 3 is a detail side-view of the folding rod supported in the lugs of the top-pieces. Fig. 4 is a perspective view of my improved frame for door-awnings, shown in extended position and ready for use. Figs. 5, 6, 7 and 8 are details showing the connection of the uprights with the lower side-braces, the inclined top-pieces and the transverse braces. Fig. 9 is a vertical transverse section on line 9, 9, Fig. 7, showing the device for locking the folding braces in extended position. Figs. 10 and 11 are respectively a detail elevation and a plan of the joint of the top-pieces and the lug for supporting the folding top-rod, and Figs. 12 and 13 are respectively side and end views of the frame after being folded up after use.

Similar letters of reference indicate corresponding parts.

Referring to the drawings, A represents a number of uprights, which are arranged in two sets and which are preferably made of gas-pipe or other suitable material. The uprights A are provided at their lower ends with pins *a*, which are inserted into sockets *a'* that are secured permanently in the pavement at the place where the door-awning is to be used.

The uprights A at each side of the frame are connected near their upper and lower parts with folding side-braces B, each of which is formed of two pieces *b b'*, which are pivoted at their outer ends to lugs *b²* arranged on nipples *b³* of the uprights A and to each other at their inner ends. The piece *b* is longer than the piece *b'*, so as to extend beyond the pivot and provided at its end with a stop-flange *d*,

which extends at right angles to the piece *b* and projects under the lower edge of the connecting-piece *b'*, as shown clearly in Figs. 4 and 7.

5 A link *d'* of ring or other shape is placed over the longer piece of the folding-brace, and passed over the pivoted ends of the pieces *b* and *b'* when they are placed in line with each other, so as to lock them firmly in position and
10 prevent the accidental folding of the same. The link *d'* is retained on a notch *d²* of the longer folding-piece *b* when it is pushed back, so as to release the pivoted ends of the pieces *b* and *b'* and permit the folding of the same in the
15 position shown in Fig. 12.

The two outermost uprights *A* on each side of the frame are not connected by lower side-braces so as to form a passage-way across the sidewalk, and not interfere with the passing
20 of persons on the sidewalk. The upper ends of the uprights *A* are further connected by transverse folding-braces *B'*, which are likewise formed of pieces *b* and *b'* that are pivoted to inwardly-projecting ears *b²* of the nipples *b³*
25 at the upper ends of the uprights, as shown in Figs. 7 and 8, said transverse braces being likewise provided with locking-links *d'* for holding them firmly in extended position, so as to secure the uprights at one side of the
30 frame at the proper distance from the uprights in the other side of the frame.

The nipples *b³* at the upper ends of the uprights *A* are further provided with upwardly-projecting ears *b⁴*, to which are pivoted
35 the lower ends of inclined top-pieces *C*, the upper ends being provided with nipples *e* which are connected by pivots *e'* that are headed at one end and provided at the opposite end with a recessed and upwardly-extending lug *e²*, which serves for supporting a
40 longitudinal folding-rod *D*, by which and the inclined top-pieces *C* the top-part of the door-awning is supported.

The folding-rod *D* is made of a number of
45 pivotally-connected links, as shown in Fig. 3, and in the detail Figs. 10 and 11, so that the same can be adapted to ordinary door-awning frames, or to frames which are arranged in connection with the steps of a building, as
50 shown respectively in Figs. 1 and 2. The folding-rod *D* is removed when the awning-frame is folded together, and forms the only detachable part of the entire frame.

To the innermost uprights are pivoted, near
55 their lower parts hooks *f*, by which the connection with eyes *f'* on the jambs of the door is made, so that the awning has an additional connection with a stationary portion of the building with which it is used, besides
60 the sockets for the lower ends of the uprights. The nipples of the outermost uprights *A* are further provided with outwardly-extending ears *b⁵*, shown in Fig. 4, to which are pivoted converging-bars *E*, which are pivotally connected at their outer ends and also provided
65 with a recessed lug *e²*.

The converging-bars *E* can be readily swung

from their upright position alongside of the top-pieces *C* into a horizontal and outwardly-extending position, as shown in Fig. 4, so as
70 to support in connection with the inclined front-end of the folding-rod *D* the forwardly-extending top-portion of the awning and enable persons alighting from carriages to pass to the door-awning without getting wet in case
75 of rain.

After the awning frame is extended and placed in position, the canvas-covering is spread first over the inclined top-pieces and the longitudinal supporting-rod *D*, after
80 which the forwardly-extending front-end of the awning is placed over the converging-bars *E* and finally the side-pieces dropped over the uprights at opposite sides of the frame in the usual manner.
85

When the door-awning is to be removed, the canvas-covering is first removed from the supporting-frame, after which the frame is folded up by releasing all the locking-devices of the longitudinal and transverse braces,
90 folding first the side-braces so that the uprights can be moved close together, as shown in Fig. 12, next folding the transverse braces so that the corresponding uprights at the opposite side can be brought close to the uprights at one side, while simultaneously the
95 braces are folded in downward position and the inclined top-pieces in upward direction close to each other, as shown in Fig. 13. The loose top-rod *D* is then removed and bundled
100 up with the folded frame, the converging end-bars being likewise moved on their hinges in upward direction against the folded top-pieces of the end uprights, as shown in Fig. 12. The awning-frame is thus folded up
105 within a comparatively small compass, so that it can be readily removed to the inside of the building or placed in a wagon and returned to the shop, according as the awning belongs to the building with which it is used or be-
110 longs to the party who rents such door-awnings for special occasions.

My improved awning-frame is in every respect superior to the awnings formed of detachable pieces heretofore in use, as all the
115 parts of the structure are always connected and have no loose portions about them, so that the awning can be put up for use in a few minutes and likewise folded together in a few
120 minutes, when not required for use, it forming thereby a very handy, time-saving and useful frame for door-awnings of all kinds.

Having thus described my invention, I claim as new and desire to secure by Letters
125 Patent—

1. A supporting-frame for door-awnings, consisting of two sets of uprights, folding side-braces connecting the upper and lower parts of the uprights, and each side-brace having its pivotal connection located at a point approximately midway of the length thereof,
130 transverse braces for connecting the upper ends of opposite pairs of uprights, inclined top-pieces pivoted to each other and to the

upper ends of the opposite uprights, and means for locking the folding side and transverse braces when in an extended position so as to hold the uprights firmly in position, substantially as set forth.

2. A supporting-frame for door-awnings, composed of two sets of uprights, each set being provided with folding side-braces at the upper and lower ends of the uprights, means for locking the braces together when they are in extended position, transverse folding-braces connecting the upper ends of opposite pairs of uprights, means for locking said transverse braces in extended position, inclined and folding top-pieces pivoted to each other and to the upper ends of the uprights, the pivots connecting the upper ends of the top-pieces being provided with upwardly-extending lugs having open recesses in their outer ends, and a longitudinal folding-rod supported in the recessed lugs for supporting the top-part of the awning, substantially as set forth.

3. A supporting-frame for door-awnings, composed of two sets of uprights, folding side-braces applied to the upper and lower ends of said uprights, and each side-brace having its pivotal connection located at a point approximately midway of the length thereof, transverse folding-braces connecting opposite pairs of uprights, inclined and folding top-pieces pivoted to each other at their upper ends and to the upper ends of the opposite uprights, and pivoted connecting hooks applied to the innermost pair of opposite uprights and adapted to form connection with stationary eyes on the jambs of the door, substantially as set forth.

4. A supporting-frame for door-awnings, composed of two sets of uprights, each upright having a bottom pin adapted to engage a socket in the side-walk or other support, folding side-braces connecting the lower ends of the uprights, excepting the outermost pair of uprights, folding side-braces connecting the upper ends of the uprights, each folding side-brace having its pivotal connection located at a point about midway of the length thereof,

transverse folding braces connecting the upper ends of opposite pairs of uprights, inclined top-pieces pivoted to each other and to the upper ends of opposite uprights, hooks pivoted to the innermost uprights, and adapted to engage with stationary eyes on the jambs of the door, and converging bars hinged to the upper ends of the outermost uprights and adapted to be moved into horizontal or vertical position, said side and transverse braces being provided with devices for locking them together when in extended position, substantially as set forth.

5. A supporting-frame for door-awnings, composed of two sets of uprights, folding side-braces at the upper and lower parts of said uprights, each side brace having its pivotal connection located at a point approximately midway of the length thereof, transverse folding braces for connecting the upper ends of opposite pairs of uprights, inclined top-pieces pivoted to each other and to the upper ends of opposite pairs of uprights, lugs at the upper ends of said top-pieces having open recesses in their outer ends, converging bars pivoted to the outermost uprights, and a longitudinal folding-rod supported in the recesses of said lugs, substantially as set forth.

6. The combination in a supporting-frame for door-awnings, of two sets of uprights, folding side-braces at the upper and lower parts of said uprights, transverse folding-braces connecting opposite pairs of uprights, each of said braces comprising two pieces pivoted together at a point about midway of the length of the braces, and one piece of each brace being extended and provided with a shoulder adapted to engage the other piece, and a locking link passing over the pivoted ends of the folding pieces, substantially as set forth.

In testimony that I claim the foregoing as my invention I have signed my name in presence of two subscribing witnesses.

JOSEPH ZERFAS.

Witnesses:

PAUL GOEPEL,
K. R. BRENNAN.