

(12) INTERNATIONAL APPLICATION PUBLISHED UNDER THE PATENT COOPERATION TREATY (PCT)

(19) World Intellectual Property Organization
International Bureau



(43) International Publication Date
26 September 2002 (26.09.2002)

PCT

(10) International Publication Number
WO 02/075794 A2

- (51) International Patent Classification⁷: **H01L 21/00**, 21/30, 21/46, 21/301 (74) Agent: **MUIR, Gregory, R.**; Reflectivity, Inc., Suite 103, 3910 Freedom Circle, Santa Clara, CA 95054 (US).
- (21) International Application Number: PCT/US02/07761 (81) Designated States (*national*): AE, AG, AL, AM, AT, AU, AZ, BA, BB, BG, BR, BY, BZ, CA, CH, CN, CO, CR, CU, CZ, DE, DK, DM, DZ, EC, EE, ES, FI, GB, GD, GE, GH, GM, HR, HU, ID, IL, IN, IS, JP, KE, KG, KP, KR, KZ, LC, LK, LR, LS, LT, LU, LV, MA, MD, MG, MK, MN, MW, MX, MZ, NO, NZ, OM, PH, PL, PT, RO, RU, SD, SE, SG, SI, SK, SL, TJ, TM, TN, TR, TT, TZ, UA, UG, US, UZ, VN, YU, ZA, ZM, ZW.
- (22) International Filing Date: 15 March 2002 (15.03.2002)
- (25) Filing Language: English
- (26) Publication Language: English
- (30) Priority Data:
60/276,222 15 March 2001 (15.03.2001) US
10/005,308 3 December 2001 (03.12.2001) US
- (71) Applicant (*for all designated States except US*): **REFLECTIVITY, INC.** [US/US]; Suite 103, 3910 Freedom Circle, Santa Clara, CA 95054 (US).
- (72) Inventors; and
- (75) Inventors/Applicants (*for US only*): **PATEL, Satyadev, R.** [US/US]; Apt. #86, 5201 Laguna Oaks Drive, Elk Grove, CA 95758 (US). **HUIBERS, Andrew, G.** [US/US]; Apartment #7, 1760 California Street, Mountain View, Ca 94041 (US).
- (84) Designated States (*regional*): ARIPO patent (GH, GM, KE, LS, MW, MZ, SD, SL, SZ, TZ, UG, ZM, ZW), Eurasian patent (AM, AZ, BY, KG, KZ, MD, RU, TJ, TM), European patent (AT, BE, CH, CY, DE, DK, ES, FI, FR, GB, GR, IE, IT, LU, MC, NL, PT, SE, TR), OAPI patent (BF, BJ, CF, CG, CI, CM, GA, GN, GQ, GW, ML, MR, NE, SN, TD, TG).

Published:

— *without international search report and to be republished upon receipt of that report*

For two-letter codes and other abbreviations, refer to the "Guidance Notes on Codes and Abbreviations" appearing at the beginning of each regular issue of the PCT Gazette.



WO 02/075794 A2

(54) Title: A METHOD FOR MAKING A MICROMECHANICAL DEVICE BY USING A SACRIFICIAL SUBSTRATE

(57) Abstract: A method is disclosed for forming a micromechanical device. The method includes fully or partially forming one or more micromechanical structures multiple times on a first substrate. A second substrate is bonded onto the first substrate so as to cover the multiple areas each having one or more micromechanical structures, so as to form a substrate assembly. The substrate assembly is then separated into individual dies, each die having the one or more micromechanical structures held on a portion of the first substrate, with a portion of the second substrate bonded to the first substrate portion. Finally, the second substrate portion is removed from each die to expose the one or more micromechanical structures on the first substrate portion. The invention is also directed to a method for forming a micromechanical device, including: forming one or more micromechanical structures in one or more areas on a first substrate; bonding caps onto the first substrate so as to cover the one or more areas each having one or more micromechanical structures, so as to form a substrate assembly; after a period of time, removing the caps to expose the one or more micromechanical structures. During the period of time between bonding the caps and later removing the caps, the substrate assembly can be singulated, inspected, irradiated, annealed, die attached, shipped and/or stored.

5

A METHOD FOR MAKING A MICROMECHANICAL DEVICE
BY USING A SACRIFICIAL SUBSTRATE

BACKGROUND

This application claims priority to provisional application 60/276,222 to Patel et al. filed March 15,
10 2001 and is a continuation-in-part of US application 10/005,308 to Patel et al. filed December 03, 2001,
both applications being incorporated herein by reference.

Field of Invention

A wide variety of micro-electromechanical devices (MEMS) are known, including accelerometers,
15 DC relay and RF switches, optical cross connects and optical switches, microlenses, reflectors and beam
splitters, filters, oscillators and antenna system components, variable capacitors and inductors, switched
banks of filters, resonant comb-drives and resonant beams, and micromirror arrays for direct view and
projection displays. Though the processes for making the various MEMS devices may vary, they all
share the need for high throughput manufacturing (e.g. forming multiple MEMS devices on a single
20 substrate without damage to the microstructures formed on the substrate). The subject matter of the
present invention is related to manufacturing of multiple MEMS devices on a substrate, singulating the
substrate and packaging each substrate portion with one or more MEMS devices thereon, without
damaging the MEMS microstructures thereon.

25 Related Art

As disclosed in US patent 5,061,049 to Hornbeck, silicon wafers are processed to form an array
of deflectable beams, then the wafers are diced into chips, followed by further processing of the individual
chips. This process has disadvantages, as disclosed in US patent 5,445,559 to Gale et al. Once the
mirror is formed by etching the sacrificial material to form an air gap between the deflectable beam and a
30 lower electrode, the device is very fragile. The device cannot be exposed to liquids during wafer cleanup
steps, without destroying the mirror. "Therefore, the devices must be cut and the dicing debris washed
away before etching the sacrificial layer away from the mirror. This requires that the cleaning and etching
steps, and any following steps, including testing be performed on the individual chips instead of a wafer."
To address this problem, Gale et al. propose using a vacuum fixture with a plurality of headspaces above
35 the mirrors to prevent contact with the mirrors. The headspaces are evacuated through vacuum ports
and the backside of the wafer is ground down to partially sawn kerfs in order to separate the devices.
Then the separated devices and the vacuum fixture are washed to remove any debris from the separation
operation. The devices with mirrors exposed are finally ready for packaging.

5 In US patent 5,527,744 to Mignardi et al., it is likewise desired to avoid damaging the mirror elements when cutting the wafer into individual dies. In Mignardi et al., a partial saw or scribe is performed on the wafer after optionally putting a removable protective coating over the entire wafer to further limit debris from the partial saw or scribe from settling on the mirrors. Then, the protective coating if used and the debris from the partial saw are removed in a post-saw cleaning. Typically the sacrificial layer is then removed, and additional processes may also take place to cover or protect various surfaces of the device that were not exposed previous to removing the sacrificial layer. Last, in order to separate the wafer into individual devices, tape is aligned and applied to the wafer, covering the partially sawed areas. The wafer is broken and the tape is treated with UV light to weaken it and then is peeled away. The individual devices with exposed mirrors must then be carefully picked and placed off of the saw frame and packaged.

10 US patent 5,872,046 to Kaeriyama et al., discloses partially fabricating a micromirror structure on a semiconductor wafer, followed by coating the wafer with a protective layer. Then, streets are sawed in the wafer (defining the individual dies), which is followed by cleaning the wafer with a solution of an alkyl glycol and HF. Further processing includes acoustically vibrating the wafer in deionized water. Finally the mirrors are released and the wafer broken along the streets.

SUMMARY OF THE INVENTION

As can be seen from the above, great care must be taken to avoid damaging or contaminating the delicate microstructures. Many time consuming and expensive steps can be involved in order to protect the mirror elements prior to singulating and packaging, and even with such protective measures, the mirrors can still be excessively exposed to potential damage. What is needed is an easier and less expensive way to make, assemble and ultimately package MEMS devices, such as mirror arrays, that avoids the problems of the prior art. In the present invention, a method is provided where the wafer substrate holding the microstructures is bonded to a sealing wafer to form a wafer assembly, which sealing wafer is removed after singulation (scribing, scoring, cutting, grinding or otherwise separating the wafer assembly into individual dies). The time that the mirrors are exposed is minimized by having the microstructures encased between two wafers prior to separation into individual dies.

A method is thus provided for forming a MEMS device, comprising providing a first wafer to hold a plurality of microstructures, providing a sealing wafer, forming a plurality of MEMS elements on the first wafer, bonding the first wafer and sealing wafer together as a wafer assembly, singulating the wafer assembly into individual dies, and finally removing the sealing wafer portion at the die level. The MEMS elements formed can be released prior to bonding the first wafer and sealing wafer, or after the sealing wafer portion has been removed. It may also be desirable to add a replacement substrate after removing the sealing wafer portion, which replacement substrate can be of a different material than the sealing

5 wafer. The replacement substrate can be a simple glass substrate or a silicon substrate such as one comprising circuitry for interacting with or otherwise actuating the microstructures on the first wafer portion.

The invention is also directed to a method for forming a micromechanical device, comprising: fully or partially forming one or more micromechanical structures multiple times on a first substrate;
10 bonding a second substrate onto the first substrate so as to cover the multiple areas each having one or more micromechanical structures, so as to form a substrate assembly; separating the substrate assembly into individual dies, each die having the one or more micromechanical structures held on a portion of the first substrate, with a portion of the second substrate bonded to the first substrate portion; and removing the second substrate portion from each die to expose the one or more micromechanical structures on the
15 first substrate portion.

The invention is further directed to a method for forming a plurality of micromirror arrays comprising micromirrors, the method comprising: forming micromirror arrays multiple times on a first substrate; bonding a second substrate onto the first substrate so as to cover the multiple areas each having a micromirror array, so as to form a substrate assembly; separating the substrate assembly into
20 individual dies, each die having a micromirror array on a portion of the first substrate with a portion of the second substrate bonded to the first substrate portion; and removing the second substrate portion from each die to expose the one or more micromechanical structures on the first substrate portion.

The invention is also directed to a method for forming a micromechanical device, comprising: forming one or more micromechanical structures in one or more areas on a first substrate; bonding caps
25 onto the first substrate so as to cover the one or more areas each having one or more micromechanical structures, so as to form a substrate assembly; after a period of time, removing the caps to expose the one or more micromechanical structures. During the period of time between bonding the caps and later removing the caps, the substrate assembly can be singulated, inspected, irradiated, annealed, die attached, shipped and/or stored.

30

BRIEF DESCRIPTION OF THE DRAWINGS

Figs. 1A to 1E illustrate one method for forming micromirrors;

Fig. 2 is a top view of a micromirror showing line 1-1 for taking the cross section for Figs. 1A to
35 1E;

Figs. 3A to 3E illustrate the same method as in Figs. 1A to 1D but taken along a different cross section;

Fig. 4 is a top view of a mirror showing line 3-3 for taking the cross section for Figs. 3A to 3E;

- 5 Fig. 5 is an illustration of the I/O pads and Si backplane for the mirror array of the present invention;
- Fig. 6 is a flow chart of one method of the invention;
- Fig. 7 is a flow chart of an alternative method of the invention;
- Fig. 8 is a top view of a wafer substrate having multiple die areas;
- 10 Figs. 9A to 9G are step-by-step views of the device being made; and
- Figs. 10A to 10G are cross sectional views of one embodiment for packaging the invention;
- Figs. 11A to 11D are illustrations of different embodiments for electrical testing of the micromechanical structures of the invention;
- Figs. 12A to 12D are illustrations of an alternate embodiment of the invention; and
- 15 Figs. 13A to 13D are illustrations of a further embodiment of the invention.

DETAILED DESCRIPTION

Mirror Fabrication:

Processes for microfabricating a MEMS device such as a movable micromirror and mirror array are disclosed in U.S. patents 5,835,256 and 6,046,840 both to Huibers, the subject matter of each being incorporated herein by reference. A similar process for forming MEMS movable elements (e.g. mirrors) on a wafer substrate (e.g. a light transmissive substrate or a substrate comprising CMOS or other circuitry) is illustrated in Figs. 1 to 4. By "light transmissive", it is meant that the material will be transmissive to light at least in operation of the device (The material could temporarily have a light blocking layer on it to improve the ability to handle the substrate during manufacture, or a partial light blocking layer for decreasing light scatter during use. Regardless, a portion of the substrate, for visible light applications, is preferably transmissive to visible light during use so that light can pass into the device, be reflected by the mirrors, and pass back out of the device. Of course, not all embodiments will use a light transmissive substrate). By "wafer" it is meant any substrate on which multiple microstructures or microstructure arrays are to be formed and which allows for being divided into dies, each die having one or more microstructures thereon. Though not in every situation, often each die is one device or product to be packaged and sold separately. Forming multiple "products" or dies on a larger substrate or wafer allows for lower and faster manufacturing costs as compared to forming each die separately. Of course the wafers can be any size or shape, though it is preferred that the wafers be the conventional round or substantially round wafers (e.g. 4", 6" or 12" in diameter) so as to allow for manufacture in a standard foundry.

Figs. 1A to 1D show a manufacturing process for a micromechanical mirror structure. As can be seen in Fig. 1A, a substrate such as glass (e.g. 1737F), quartz, Pyrex™, sapphire, (or silicon alone or with circuitry thereon) etc. is provided. The cross section of Figs. 1A-D is taken along line 1-1 of Fig. 2.

5 Because this cross section is taken along the hinge of the movable element, an optional block layer 12 can be provided to block light (incident through the light transmissive substrate during use) from reflecting off of the hinge and potentially causing diffraction and lowering the contrast ratio (if the substrate is transparent).

As can be seen in Fig. 1B, a sacrificial layer 14, such as amorphous silicon, is deposited. The
10 thickness of the sacrificial layer can be wide ranging depending upon the movable element/mirror size and desired tilt angle, though a thickness of from 500Å to 50,000 Å, preferably around 5000 Å is preferred. Alternatively the sacrificial layer could be a polymer or polyimide (or even polysilicon, silicon nitride, silicon dioxide, etc. depending upon the materials selected to be resistant to the etchant, and the etchant selected). A lithography step followed by a sacrificial layer etch forms holes 16a,b in the
15 sacrificial silicon, which can be any suitable size, though preferably having a diameter of from .1 to 1.5 um, more preferably around .7 +/- .25um. The etching is performed down to the glass/quartz substrate or down to the block layer if present. Preferably if the glass/quartz layer is etched, it is in an amount less than 2000 Å.

At this point, as can be seen in Fig. 1C, a first layer 18 is deposited by chemical vapor
20 deposition. Preferably the material is silicon nitride or silicon oxide deposited by LPCVD or PECVD, however polysilicon, silicon carbide or an organic compound could be deposited at this point (of course the sacrificial layer and etchant should be adapted to the material used). The thickness of this first layer can vary depending upon the movable element size and desired amount of stiffness of the element, however in one embodiment the layer has a thickness of from 100 to 3200 Å, more preferably around
25 1100 Å. The first layer undergoes lithography and etching so as to form gaps between adjacent movable elements on the order of from .1 to 25 um, preferably around 1 to 2 um.

A second layer 20 (the "hinge" layer) is deposited as can be seen in Fig. 1D. By "hinge layer" it is meant the layer that defines that portion of the device that flexes to allow movement of the device. The hinge layer can be disposed only for defining the hinge, or for defining the hinge and other areas such as
30 the mirror. In any case, the reinforcing material is removed prior to depositing the hinge material. The material for the second (hinge) layer can be the same (e.g. silicon nitride) as the first layer or different (silicon oxide, silicon carbide, polysilicon, etc.) and can be deposited by chemical vapor deposition as for the first layer. The thickness of the second/hinge layer can be greater or less than the first, depending upon the stiffness of the movable element, the flexibility of the hinge desired, the material used, etc. In
35 one embodiment the second layer has a thickness of from 50 Å to 2100 Å, and preferably around 500 Å. In another embodiment, the first layer is deposited by PECVD and the second layer by LPCVD.

As also seen in Fig. 1D, a reflective and conductive layer 22 is deposited. The reflective/conductive material can be gold, aluminum or other metal, or an alloy of more than one metal though it is preferably aluminum deposited by PVD. The thickness of the metal layer can be from 50 to

5 2000 Å, preferably around 500 Å. It is also possible to deposit separate reflective and conductive layers. An optional metal passivation layer (not shown) can be added, e.g. a 10 to 1100 Å silicon oxide layer deposited by PECVD. Then, photoresist patterning on the metal layer is followed by etching through the metal layer with a suitable metal etchant. In the case of an aluminum layer, a chlorine (or bromine) chemistry can be used (e.g. a plasma/RIE etch with Cl₂ and/or BCl₃ (or Cl₂, CCl₄, Br₂, CBr₄, etc.) with an
10 optional preferably inert diluent such as Ar and/or He).

In the embodiment illustrated in Figs. 1A to 1D, both the first and second layers are deposited in the area defining the movable (mirror) element, whereas the second layer, in the absence of the first layer, is deposited in the area of the hinge. It is also possible to use more than two layers to produce a laminate movable element, which can be desirable particularly when the size of the movable element is
15 increased such as for switching light beams in an optical switch. A plurality of layers could be provided in place of single layer 18 in Fig. 1C, and a plurality of layers could be provided in place of layer 20 and in place of layer 22. Or, layers 20 and 22 could be a single layer, e.g. a pure metal layer or a metal alloy layer or a layer that is a mixture of e.g. a dielectric or semiconductor and a metal. Some materials for such layer or layers that could comprise alloys of metals and dielectrics or compounds of metals and
20 nitrogen, oxygen or carbon (particularly the transition metals) are disclosed in U.S provisional patent application 60/228,007, the subject matter of which is incorporated herein by reference.

Whatever the specific combination, it is desirable that the reinforcing layer(s) is provided and patterned (at least in the hinge area) prior to depositing and patterning the hinge material and metal. In one embodiment, the reinforcing layer is removed in the area of the hinge, followed by depositing the
25 hinge layer and patterning both reinforcing and hinge layer together. This joint patterning of the reinforcing layer and hinge layer can be done with the same etchant (e.g. if the two layers are of the same material) or consecutively with different etchants. The reinforcing and hinge layers can be etched with a chlorine chemistry or a fluorine (or other halide) chemistry (e.g. a plasma/RIE etch with F₂, CF₄, CHF₃, C₃F₈, CH₂F₂, C₂F₆, SF₆, etc. or more likely combinations of the above or with additional gases, such as
30 CF₄/H₂, SF₆/Cl₂, or gases using more than one etching species such as CF₂Cl₂, all possibly with one or more optional inert diluents). Of course, if different materials are used for the reinforcing layer and the hinge layer, then a different etchant can be employed for etching each layer. Alternatively, the reflective layer can be deposited before the first (reinforcing) and/or second (hinge) layer. Whether deposited prior to the hinge material or prior to both the hinge material and the reinforcing material, it is preferable that
35 the metal be patterned (e.g. removed in the hinge area) prior to depositing and patterning the hinge material.

Figures 3A to 3D illustrate the same process taken along a different cross section (cross section 3-3 in Fig. 4) and show the optional block layer 12 deposited on the light transmissive substrate 10, followed by the sacrificial layer 14, layers 18, 20 and the metal layer 22. The cross sections in Figs. 1A to

5 1D and 3A to 3D are taken along substantially square mirrors in Figs. 2 and 4 respectively. However, the mirrors need not be square but can have other shapes that may decrease diffraction and increase the contrast ratio. Such mirrors are disclosed in U.S. provisional patent application 60/229,246 to Ilkov et al., the subject matter of which is incorporated herein by reference. Also, the mirror hinges can be torsion hinges as illustrated in this provisional application.

10 It should also be noted that materials and method mentioned above are examples only, as many other method and materials could be used. For example, the Sandia SUMMiT process (using polysilicon for structural layers) or the Cronos MUMPS process (also polysilicon for structural layers) could be used in the present invention. Also, a MOSIS process (AMI ABN – 1.5 um CMOS process) could be adapted for the present invention, as could a MUSiC process (using polycrystalline SiC for the structural layers) as
15 disclosed, for example, in Mehregany et al., Thin Solid Films, v. 355-356, pp. 518-524, 1999. Also, the sacrificial layer and etchant disclosed herein are exemplary only. For example, a silicon dioxide sacrificial layer could be used and removed with HF (or HF/HCl), or a silicon sacrificial could be removed with ClF₃ or BrF₃. Also a PSG sacrificial layer could be removed with buffered HF, or an organic sacrificial such as polyimide could be removed in a dry plasma oxygen release step. Of course the etchant and sacrificial
20 material should be selected depending upon the structural material to be used. Also, though PVD and CVD are referred to above, other thin film deposition methods could be used for depositing the layers, including spin-on, sputtering, anodization, oxidation, electroplating and evaporation.

After forming the microstructures as in Figs. 1 to 4 on the first wafer, it is preferably to remove the sacrificial layer so as to release the microstructures (in this case micromirrors). This release can be
25 performed at the die level, though it is preferred to perform the release at the wafer level. Figs. 1E and 3E show the microstructures in their released state. As can be seen in Fig. 1E, posts 2 hold the released microstructure on substrate 10.

Circuitry:

30 In the present invention, the circuitry can be formed together on the same substrate as the microstructures, such as in the aforementioned US patents 5,061,049, 5,527,744, and 5,872,046, the subject matter of each being incorporated by reference. If the microstructures and circuitry are formed monolithically on the same first wafer, then after the sealing wafer is removed, a simple final replacement
35 substrate can be added (e.g. a simple semiconductive or insulating substrate (e.g. a silicon, glass, quartz or other substrate) that is bonded to the first wafer portion at the die level after removal of the sealing wafer portion. Of course, if the device is for modulation of light in the visible spectrum such as for an optical switch or a spatial light modulator for a projection display, then the replacement substrate is preferably transmissive to light in the visible spectrum.

5 If the circuitry is not formed monolithically on the same wafer as the microstructures, then the replacement substrate can comprise circuitry (or, circuitry could be provided on both the first wafer and the replacement substrate if desired). If the microstructures are micromirrors, then it may be preferable to form circuitry and electrodes on the replacement wafer prior to replacing the sealing wafer at the die level. In such a case, it may be preferable for the replacement substrate (the backplane) die to contain a large
10 array of electrodes on a top metal layer of the die, each electrode electrostatically controlling one pixel (one micromirror on the first wafer portion of the die) of the microdisplay. The voltage on each electrode on the surface of the backplane determines whether its corresponding microdisplay pixel is optically 'on' or 'off,' forming a visible image on the microdisplay. Details of the backplane and methods for producing a pulse-width-modulated grayscale or color image are disclosed in U.S. patent application 09/564,069 to
15 Richards, the subject matter of which is incorporated herein by reference.

 The display pixels themselves, in a preferred embodiment, are binary, always either fully 'on' or fully 'off,' and so the backplane design is purely digital. Though the micromirrors could be operated in analog mode, no analog capability is necessary. For ease of system design, the backplane's I/O and control logic preferably run at a voltage compatible with standard logic levels, e.g. 5V or 3.3V. To
20 maximize the voltage available to drive the pixels, the backplane's array circuitry may run from a separate supply, preferably at a higher voltage.

 One embodiment of the backplane can be fabricated in a foundry 5V logic process. The mirror electrodes can run at 0-5V or as high above 5V as reliability allows. The backplane could also be fabricated in a higher-voltage process such as a foundry Flash memory process using that process's
25 high-voltage devices. The backplane could also be constructed in a high-voltage process with larger-geometry transistors capable of operating at 12V or more. A higher voltage backplane can produce an electrode voltage swing significantly higher than the 5-7V that the lower voltage backplane provides, and thus actuate the pixels more robustly.

 In digital mode, it is possible to set each electrode to either state (on/off), and have that state
30 persist until the state of the electrode is written again. A RAM-like structure, with one bit per pixel is one architecture that accomplishes this. One example is an SRAM-based pixel cell. Alternate well-known storage elements such as latches or DRAM (pass transistor plus capacitor) are also possible. If a dynamic storage element (e.g. a DRAM-like cell) is used, it is desirable that it be shielded from incident light that might otherwise cause leakage.

 The perception of a grayscale or full-color image will be produced by modulating pixels rapidly on
35 and off, for example according to the method in the above-mentioned U.S. patent application 09/564,069 to Richards. In order to support this, it is preferable that the backplane allows the array to be written in random-access fashion, though finer granularity than a row-at-a-time is generally not necessary.

5 It is desirable to minimize power consumption, primarily for thermal reasons. Decreasing electrical power dissipation will increase the optical/thermal power budget, allowing the microdisplay to tolerate the heat of more powerful lamps. Also, depending upon the way the microdisplay is assembled (wafer-to-wafer join + offset saw), it may be preferable for all I/O pads to be on one side of the die. To minimize the cost of the finished device it is desirable to minimize pin count. For example, multiplexing
10 row address or other infrequently-used control signals onto the data bus can eliminate separate pins for these functions with a negligible throughput penalty (a few percent, e.g. one clock cycle for address information per row of data is acceptable). A data bus, a clock, and a small number of control signals (5 or less) are all that is necessary.

In use, the die can be illuminated with a 50W or more arc lamp. The thermal and photo-carrier
15 effects of this may result in special layout efforts to make the metal layers as 'opaque' as possible over the active circuitry to reflect incident optical energy and minimize photocarrier and thermal effects. An on-chip PN diode could be included for measuring the temperature of the die.

In one embodiment the resolution is XGA, 1024x768 pixels, though other resolutions are possible. A pixel pitch of from 5 to 24 um is preferred (e.g. 14 um). The size of the electrode array itself
20 is determined by the pixel pitch and resolution. A 14um XGA device's pixel array will therefore be 14.336x10.752mm.

As can be seen in Fig. 5, the I/O pads (88) can be placed along the right edge of the die, as the die is viewed with pixel (0,0) (89 in Fig. 5) at the top left corner. Putting the pads on the 'short' (left/right)
25 edge (87) of the die is preferable due to the slightly reduced die size. The choice of whether the I/O should go on the left vs. right edge of the die is of little importance since the display controller ASIC may support mirroring the displayed image in the horizontal axis, the vertical axis, or both. If it is desired to orient the display with the I/O on the left edge, the image may simply be rotated 180 degrees by the external display controller. The electrode voltage during operation is, in the low state 0V and in the high state preferably from 5 to 7 V (or 12V or higher in the higher voltage design). Of course other voltages
30 are possible, though lower actuation voltages are preferred. In one embodiment the electrodes are metal squares, though other geometries are possible. Standard CMOS passivation stackup over the electrodes can be provided.

Assembly:

35 In one embodiment, the circuitry is formed together with the microstructures on the first wafer (Step 30 in Fig. 6), then the sealing wafer is added at the wafer level (Step 31), the wafer assembly divided into individual dies (Step 32), and the sealing wafer (portion) removed at the die level (Step 33). This can be followed, if desired, by the addition of a replacement substrate at the die level (Step 34), before or during final packaging.

5 In another embodiment, if the circuitry is formed on a separate substrate from the microstructures, then it is preferable to form multiple circuit "dies" on a single substrate (Step 40 in Fig 7), for example on a silicon wafer, followed by separation of the wafer into individual circuit dies (Step 41). Likewise, multiple microstructures or microstructure arrays are formed on the first wafer substrate (Step 45), followed by bonding the first wafer to a sealing wafer (Step 46). This is in turn followed by singulating the assembly of
10 the first and sealing wafers into dies (Step 47) and removing the sealing wafer portion from each die (Step 48). The circuit wafer portion and the first wafer portion with microstructures are aligned and bonded (Step 49) before or during final packaging. The microstructures can be released or unreleased prior to adhering the sealing wafer to the first wafer, though the invention is particularly suited to the more delicate released MEMS devices.

15 Releasing immediately prior to the application of epoxy or other bonding is preferable (though an anti-stiction treatment or other passivation treatment (or treatment for improving epoxy bond strength) between release and bonding may be desirable). For silicon sacrificial layers, the release can be in an atmosphere of xenon difluoride and an optional diluent (e.g. nitrogen and/or helium). Of course, other etchants could be used, including interhalogens such as bromine trifluoride and bromine trichloride, gas
20 phase or liquid phase HF, or other suitable etchant. The release is preferably a spontaneous chemical etch which does not require plasma or other external energy to etch the silicon sacrificial layer(s). After etching, the remainder of the device can be treated for stiction by applying an anti-stiction layer (e.g. a self assembled monolayer). The layer is preferably formed by placing the device in a liquid or gas silane, preferably a halosilane, and most preferably a chlorosilane. Of course, many different silanes and other
25 materials are known in the art for their ability to provide anti-stiction for MEMS structures.

The bonding of the removable sealing wafer to the first wafer holding the microstructures can be by anodic bonding, metal eutectic bonding, fusion bonding, epoxy bonding, or other wafer bonding processes known in the art. A preferred bonding method is bonding with an IR or UV epoxy such as disclosed in US patent 5,963,289 to Stefanov et al, "Asymmetrical Scribe and Separation Method of
30 Manufacturing Liquid Crystal Devices on Silicon Wafers", which is hereby incorporated by reference. In order to maintain separation between the bonded wafers, spacers can be mixed into the epoxy. The spacers can be in the form of spheres or rods and can be dispensed and dispersed between the first wafer and sealing wafer in order to keep the sealing wafer spaced away from the first wafer (so as to avoid damage to the microstructures on the first wafer). Spacers can be dispensed in the gasket area of
35 the display and therefore mixed into the gasket seal material prior to seal dispensing. This is achieved through normal agitated mixing processes. The final target for the gap between the first wafer and sealing wafer can be from 1 to 100 um. This of course depends upon the type of MEMS structure being encapsulated and whether it was surface or bulk micromachined (bulk micromachined structures may not need any spacers between the two wafers). The spheres or rods can be made of glass or plastic,

5 preferably an elastically deforming material. Alternatively, spacer pillars can be microfabricated on at least one of the wafer substrates. In one embodiment, pillars/spacers are provided only at the edge of the array. In another embodiment, pillars/spacers can be fabricated in the array itself. If the spacers are micro-fabricated spacers, they can be formed on the lower wafer, followed by the dispensing of an epoxy, polymer, or other adhesive (e.g. a multi-part epoxy, or a heat or UV-cured adhesive) adjacent to the
10 micro-fabricated spacers. The adhesive and spacers need not be co-located, but could be deposited in different areas on the lower substrate wafer. Alternative to glue, a compression bond material could be used that would allow for adhesion of the upper and lower wafers. Spacers micro-fabricated on the lower wafer (or the upper wafer) and could be made of polyimide, SU-8 photo-resist.

Then, the two wafers are aligned. Because the sealing wafer will eventually be removed and
15 discarded, high precision alignment may not be necessary. If precision alignment is desired, alignment of the opposing electrodes or active viewing areas may involve registration of substrate fiducials on opposite substrates. This task accomplished with the aid of video cameras with lens magnification. The machines range in complexity from manual to fully automated with pattern recognition capability. Whatever the level of sophistication, they accomplish the following process: 1. Dispense a very small amount of a UV
20 curable adhesive at locations near the perimeter and off of all functional devices in the array; 2. Align the fiducials of the opposing substrates within the equipment capability; and 3. Press substrates and UV tack for fixing the wafer to wafer alignment through the remaining bonding process (e.g., curing of the internal epoxy).

The final cell gap can be set by pressing the previously tacked laminates in a UV or thermal
25 press. In a UV press, a common procedure would have the substrates loaded into a press where at least one or both of the press platens are quartz, in order to allow UV radiation from a UV lamp to pass unabated to the gasket seal epoxy. Exposure time and flux rates are process parameters determined by the equipment and adhesive materials. Thermally cured epoxies may require that the top and bottom platens of a thermal press be heated. The force that can be generated between the press platens is
30 typically many pounds. With thermally cured epoxies, after the initial press the arrays are typically transferred to a stacked press fixture where they can continue to be pressed and post-cured. In one embodiment, the epoxy between the first wafer and sealing wafer is only partially cured so as to allow easier removal of the sealing wafer. After the sealing wafer is removed, this epoxy can be optionally cured. An epoxy can be selected that adheres less well (depending upon the wafer materials) than other
35 epoxies, so as to allow for easier removal of the sealing wafer after singulation. Also, UV epoxy and IR epoxy can be used at the same time, with the UV epoxy being cured prior to IR cure.

Once the wafers have been bonded together to form a wafer assembly, the assembly can be separated into individual dies. Scribes are placed on the respective substrates in an offset relationship at least along one direction. The units are then separated, resulting in each unit having a ledge on each end

5 of the die. Though not necessary, this can aid in the ability to later remove the sealing safer portion of the die. Such a ledge can also allow for electrical testing of each die, as electrical contacts can be exposed on the ledge (e.g., if circuitry has been formed together with the microstructures on the first wafer). The parts can then be separated from the array by venting the scribes on both substrates. Automatic breaking can be done by commercially available guillotine or fulcrum breaking machines. The parts can also be
10 separated by hand.

Separation may also be done by glass scribing and partial sawing of one or both substrates. Sawing is preferably done in the presence of a high-pressure jet of water. Moisture must not be allowed to contact the microstructures. Therefore, at gasket dispense, an additional gasket bead must be dispensed around the perimeter of the wafer, or each gasket bead around each die must fully enclose the die area
15 so that water can not enter and touch the microstructures. Preferably, however, the end of each scribe/saw lane must be initially left open, to let air vent during the align and press processes. After the array has been pressed and the gasket material fully or partially cured, the vents are then closed using either the gasket or end-seal material. The glass is then scribed and sawed.

Alternatively, both the first wafer and sealing wafer substrates may be partially sawed prior to
20 part separation. With the same gasket seal configuration, vent and seal processes as described above, saw lanes are aligned to fiducials on the sealing substrate. The glass is sawed to a depth between 25% and 95% of its thickness. The first wafer substrate is sawed and the parts separated as described above.

The first wafer can be any suitable substrate for the particular MEMS microstructure (and optionally circuitry) formed thereon, such as a light transmissive substrate such as glass, borosilicate,
25 tempered glass, quartz or sapphire, or any other suitable light transmissive material. Or, the first wafer could be a metal, ceramic or preferably a semiconductor wafer (e.g. silicon or GaAs). The sealing wafer is preferably from a material that is easy to handle, inexpensive and separable from the epoxy after singulation. The sealing wafer can be from any of the above materials for the first wafer, and in one embodiment, the sealing wafer is selected to have a similar coefficient of thermal expansion as the first
30 wafer. In another embodiment, the sealing wafer is from a polymer material that can be scribed or sawed and broken at the time of singulation. Of course, the polymer should have a melting point higher than any temperatures used in bonding (e.g. for an IR full or partial cure).

After singulation, the sealing wafer is removed. In one embodiment, the sealing wafer is removed by mechanical means, such as by prying the two substrates apart and preferably utilizing the
35 ledges formed by offset scribing as mentioned above. Or, depending upon the type of bonding used, or if adhesive is used, the type of adhesive, it may be preferred to heat the die in order to loosen the bond between the first wafer portion and the sealing wafer portion. In one particular embodiment, epoxy is dispensed (during bonding) on a layer of sacrificial material (this material could be anything that could be

5 removed with a suitable etchant, such as amorphous silicon, silicon dioxide, an organic material, etc.). At the time of removing the sealing wafer portion at the die level, an etchant is provided to the die to etch away this sacrificial material adjacent the dispensed epoxy. By fully or partially removing the sacrificial material, the epoxy will not longer be in contact with both substrates and the substrates will separate. In one embodiment, the sacrificial material is a layer covering substantially all of one surface of the sealing
10 wafer. Upon etching away this surface during sealing wafer removal, the sealing wafer will be removable from the first wafer so as to expose the first wafer having the microstructures (and cured epoxy) thereon.

In some embodiments it may be desirable to add a replacement cover to each die before or during packaging (or even after packaging, though it is desirable in many instances to recover the microstructures as soon as possible. The replacement substrate can be attached directly to the first
15 substrate portion, or to packaging components and held in place over the first substrate portion. The replacement substrate ("third substrate") if bonded directly to the first substrate, can be bonded by any of the known wafer bonding methods, such as those disclosed herein. In one embodiment, the replacement wafer is bonded by epoxy bonding (UV, IR/oven bake, etc.). The epoxy can be applied in the same location as the epoxy was applied for the sealing wafer, or the epoxy can be applied with spacers (the
20 same as or larger than those for the sealing wafer if the cured epoxy and spacers remain on the first substrate after sealing wafer removal).

Though the sealing wafer may be of an inexpensive and disposable material, it may be desired for the replacement substrate to be of a higher quality material, such as a silicon substrate, or a quartz or sapphire substrate, or a glass substrate with particular properties or coatings (UV block, etc.). In some
25 cases, such as for optical switching, projection displays, or other optical applications, it may be desirable to use display grade glass as the third substrate. Though display grade glass could be added at the wafer level and left in place after singulation, the amount of display grade glass can be minimized by first testing the individual dies and only adding the more expensive third substrate to those dies that pass the testing phase. Also, sawing and other singulation steps can damage display grade glass and or glass
30 coatings. Therefore, using a disposable substrate for wafer singulation and adding the display grade glass at the end, can help to minimize damage.

As an example, reference is made to Fig. 8 where 45 die areas have been formed on wafer 5. Each die area 3 (having a length A and a height B) comprises one or more (preferably released) microstructures. In the case of micromirror arrays for projection systems, each die preferably has at least
35 1000 movable mirrors, and more likely between 1 and 6 million movable elements. Of course, if the microstructure is a DC relay or RF MEMS switch (or even mirrors for an optical switch) there will likely be far fewer than millions of microstructures, more likely less than 100 or even less than 10 (or even a single structure). Of course if there are only a few microstructures in each die area, then the die areas

5 themselves can be made smaller in most cases. Also, the die areas need not be rectangular, though this shape aids in epoxy deposition and singulation.

As can be seen in Fig. 9A, four die areas 3a to 3d are formed on wafer 5 (many more dies would be formed in most circumstances, though only four are shown for ease of illustration). Each die area 3a to 3d comprises one or more microstructures that have already been released in a suitable etchant. As
10 illustrated in Fig. 9B, epoxy can be applied in the form of beads 31a to 31d along each side of the die area, or as beads 32a to 32d at each corner of the die area. Or, epoxy ribbons 33a and 33b could be applied along two sides of each die, or a single ribbon 34 could be applied substantially surrounding an entire die. Of course many other configurations are possible, though it is desirable that the die not be fully surrounded with an epoxy gasket as this will prevent air or other gas from escaping when the two wafers
15 are pressed together during a full or partial epoxy cure. And, of course, it is preferable, for higher manufacturing throughput, to use a common epoxy application method throughout the entire wafer (the different types of applications in Fig. 9B are for illustrations purposes only). Also, the areas in which epoxy is applied can first have a sacrificial material deposited in that area (preferably in an area larger than the bead or band of epoxy due to expansion of the epoxy under compression). The sacrificial
20 material could also be applied to the entire wafer except in areas having microstructures thereon.

In Fig. 9C, the sealing wafer 25 and the lower substrate wafer 5 with microstructures (and optionally circuitry) are brought into contact with each other. The final gap between the two wafers can be any size that allows the two wafers to be held together and singulated uniformly. Because gasket beads will expand upon application of pressure (thus taking up valuable real estate on a wafer with densely
25 positioned die areas), it is preferable that the gap size be larger than 1 μm , and preferably greater than 10 μm . The gap size can be regulated by providing microfabricated spacers or spacers mixed in with the epoxy (e.g. 25 μm spacers). However, spacers may not be necessary depending upon the type of microstructure and the amount of pressure applied.

Fig. 9D shows the first wafer 5 and sealing wafer 25 bonded together. Horizontal and vertical
30 score or partial saw lines 21a and 21b are provided on both the sealing wafer 25 and the first (lower) wafer 5 (lines not shown on wafer 5). Preferably the score lines on the two wafers are offset slightly from each other at least in one of the (horizontal or vertical). This offset scoring or partial sawing allows for ledges on each die when the wafer is completely singulated into individual dies (see Fig. 9E). Electrical connections 4 on ledge 6 on die 3c allow for electrical testing of the die prior to removal of the sealing
35 wafer portion. Should the die fail the electrical testing of the microstructures, the sealing wafer need not be removed and the entire die can be discarded. Otherwise, sealing wafer portion 25a (in Fig. 9F) is removed from first wafer portion 5a so as to expose the microstructures on first wafer portion 5a. Sealing wafer portion 25a is discarded. The device can be electrically and/or optically tested with the sealing wafer portion 25a before or after removal. The device can be packaged, which packaging can include a

5 replacement substrate 25r (see Fig. 9G) placed and bonded above the first wafer portion 5a, though not bonded directly to first wafer portion 5a. It is also possible to attach the die/device into a package prior to removing the sealing wafer. This allows protection of the device up till the final package closure and thus minimizes the number of processing steps performed while the micromechanical structures are not covered. Replacement substrate 25r can be a simple glass, silicon, polymer or other substrate,
10 depending upon whether optical transmissivity is needed and other needs of the packaged device. If the microstructures on first wafer portion 5a were formed in the absence of circuitry for interacting with the microstructures (e.g. detecting or causing movement of the microstructures), then the replacement substrate 25r could include such circuitry (including electrodes if desired). Such a replacement substrate could be like the backplane described herein that comprises CMOS circuitry and electrodes for causing
15 deflection of micromirrors on first wafer portion 5a. If the microstructures were formed monolithically with circuitry on the same wafer, then replacement substrate 25b could be a glass cover that might have special coatings or properties such as a UV block, anti-reflection coating, etc. as mentioned above.

There are a number of possibilities for testing and packaging the MEMS devices. In one embodiment, the devices of Fig. 9E can be bonded to a wafer or panel 50 (e.g. made of ceramic) as can
20 be seen in Fig. 10A. Then the sealing wafer portions 25a to d are removed as in Fig. 10B, after which the remaining first wafer portions 5a to d are wirebonded to panel 50 as illustrated in Fig. 10C. The wirebonding could also be performed prior to removal of sealing wafer portions 25a to d. Then, first wafer portions 5a to d are encapsulated by another panel 51 (this can be a hermetic seal) as shown in Fig. 10D, before being separated into individual packaged units 54a to d as illustrated in Fig. 10E. Panel 51 is the
25 replacement substrate mentioned hereinabove, and can be display quality glass for optical MEMS devices. An alternative panel 51 is shown in Fig. 10F, having sections 50a to d separated by precision formed gaps 59 that allow for exact X and Y dimensions for kinematic mounting (e.g. in a projection system). First substrate portion 5a will be adhered as illustrated by the dotted lines, after each panel section 50a to d has been broken off or otherwise disconnected from the single panel 50. Electrical
30 connections 58 are for wirebonding of first substrate portion 5a, and go through the panel section to the backside. A single packaged structure is shown in more detail in Fig. 10G.

Testing of the MEMS devices can be performed at one or more points in the manufacturing process. As can be seen in Fig. 11A, an electrical testing probe 55 (such as used for testing integrated circuits or one specially designed for MEMS applications) can be used to test the MEMS structures
35 formed on first wafer portion 5a while sealing wafer portion 25a is still attached. Or, as can be seen in Fig. 11B, if first wafer portion 5a is wire bonded to panel 50, then the probe can be directed to come in contact with panel 50 instead of the ledge of first wafer portion 5a. It is also possible to first remove sealing wafer portion 25a in order to create more room for the tips of the electric probe 55 to come into contact with first wafer portion 5a (see Fig. 11C). Or, as above, first wafer portion 5a can be wirebonded

5 to panel 50 and the probe 55 brought into contact with panel 50 for testing of the MEMS structures, as shown in Fig. 11D.

Specific testing can include individual actuation of the one or more MEMS structures on first wafer portion 5a and viewing the movement of the structures optically and/or capturing the movement with an image capture device such as a CCD camera. If the MEMS structures are provided as multiple
10 structures such as an array of micromirrors, each mirror could be actuated individually, or groups of mirrors (or even the entire array) could be actuated to determine whether each structure is within specifications (e.g. desired distance of movement for voltage applied). This electrical testing can be performed prior to fully packaging the devices (e.g. when the devices have been singulated and optionally
15 adhered to the back package panel 50) in order to avoid the expense of packaging devices that do not function properly. The electrical testing can also be performed after packaging, or only after packaging the devices if desired. Any electrical testing can be in addition to other types of testing (e.g. optical testing/inspection) performed at the wafer level.

Figures 12A to 12D show a variation of the process of the invention where sealing wafer 25 of Fig. 9C is a wafer having rectangular sealing wafer portions 60a to d bonded thereto. A gasket of epoxy
20 34 is applied around each die area 3a to d, as can be seen in Fig. 12A. Then wafers 25 and 5 are brought together (Fig. 12B) so as to adhere sealing wafer portions 60a to d to a corresponding die area. The adhesive that holds sealing wafer portions 60a to d to wafer 25 can lose its bonding strength by application of UV light or heat so as to allow removal of wafer 25 without removing sealing wafer portions
25 60a to d, as can be seen in Fig. 12C. Then, as can be seen in Fig. 12D, the first wafer 5 is scored to allow separation of the individual dies. It is also possible to adhere sealing wafer portions other than with epoxy, such as with metal solder. Also, wafer 25 is optional as sealing wafer portions 60a to d can be added individually one at a time or, together at the same time with a bonding machine having a specialized head piece for holding the separate sealing wafer portions. The sealing wafer portions do not have micromachined structures thereon as the process disclosed herein is not a MEMS transfer process.
30 The micromechanical elements are disposed on the first wafer portion both before and after any sealing wafer (or sealing wafer portions) are added and later removed. Other types of removable sealing caps could be used, including glass, plastic, ceramic or other caps, preferably where a cavity is part of the cap or where protrusions or a sealing rim on the cap or substrate, or spacers added at the time of bonding, allow for a cavity or headspace above each die region of the substrate comprising the multiple MEMS
35 devices. Regardless of the material of the cap, the cap need not be light transmissive – though transmissivity is preferred if optical testing or other optical or visual inspection is desired prior to removal of the cap.

It should be noted that the invention is applicable to forming micromirrors such as for a projection display or optical switch, or any other MEMS device that would benefit from protection of the

5 microstructures during wafer singulation. If an optical switch is the microstructure being protected, mirrors with multiple hinges can be provided on the first wafer so as to allow for multi-axis movement of the mirror. Such multi-axis movement, mirrors for achieving such movement, and methods for making such mirrors (including providing a reinforcing layer and removing a portion in the hinge area) are disclosed in US patent application 09/617,149 to Huibers et al., the subject matter of which is incorporated herein by
10 reference. Formation of multi-axis mirrors on a substrate, bonding a sealing wafer, and removing the sealing wafer after singulation, is described in US patent application 60/231,041 to Huibers, the subject matter of which is incorporated herein by reference.

Of course, the microstructure need not be a movable mirror (for a projection display, for optical switching, or even for data storage), but could be one or more accelerometers, DC relay and RF switches,
15 microlenses, beam splitters, filters, oscillators and antenna system components, variable capacitors and inductors, switched banks of filters, resonant comb-drives and resonant beams, etc. Any MEMS structure, particularly a released or movable structure, could benefit from the method utilizing a removable sealing wafer described herein.

The microstructure need not be formed and released by standard microfabrication techniques
20 (for example, for surface micromachining, sacrificial layer deposition, followed by thin film deposition and patterning, followed by removal of a sacrificial layer to release the MEMS structure; or for bulk micromachining, releasing the microstructure by etching into the substrate). Instead, the microstructure could be formed and released by etching all the way through a substrate so as to define (and release) the movable element. For example, as can be seen in Fig. 13A, the first wafer substrate 5 (or multiple wafers
25 laminated/bonded together) are provided, upon which are deposited electrodes 7, 9 which are electrically isolated from each other. CMOS or other circuitry can be provided on wafer 5 for actuating the MEMS device to be formed, or the circuitry can be formed on a separate substrate from the MEMS device. Insulating layer 8 is deposited prior to deposition of the electrodes, if the lower substrate wafer is not insulating. Layer 8 could alternatively be a layer for promoting adhesion of the electrodes to the lower
30 substrate wafer.

In Figure 13B, micro-fabricated spacers 15 are deposited onto first substrate wafer 5, and an epoxy, polymer, or other adhesive 11 (e.g. a multi-part epoxy, or a heat or UV-cured adhesive) is dispensed adjacent to the micro-fabricated spacers 15. The adhesive and spacers need not be co-located as illustrated, but could be deposited in different areas on the lower substrate wafer. Alternative
35 to glue, a compression bond material could be used that would allow for adhesion of the upper and lower wafers. Spacers 15 could be micro-fabricated onto the lower wafer (or the upper wafer) and could be made of polyimide, SU-8 photo-resist. Conductive adhesive 19 (or adhesive together with metallic spacers) is provided on electrode 9 for electrically connecting electrode 9 to the movable element to be formed in the upper wafer. Depending upon the size of the movable element to be formed, the spacers

5 could be microfabricated with standard thin film materials (silicon dioxide, silicon nitride, etc.). Instead of microfabrication, the spacers could be balls or rods of a predetermined size that are within the adhesive when the adhesive is placed on the lower wafer.

As can be seen in Figure 13C, wafer 1 (the wafer from which the microstructure is to be formed) is aligned and bonded to the lower substrate wafer 5. Preferably the MEMS wafer and the first wafer are
10 bonded with sufficient pressure so that both wafers contact opposite sides of the spacers (or spacing wafer). If curing of the adhesive is necessary, such curing can be fully or partly performed at this stage in the assembly. In a preferred embodiment the upper and lower wafers are made of the same material (preferably silicon), or at least have the same or nearly identical thermal coefficient of expansion (so as to avoid or reduce warping or stress-induced change in device performance over a wide temperature range.
15 However, it is not necessary for the first wafer 5 and the MEMS wafer 1 to be the same.

Figure 13D shows that if the movable elements have not already been cut or etched out of upper wafer 1 prior to bonding, then at this point portions 21 of the MEMS wafer are removed so as to define the movable element 17 (and possibly also the hinge which allows pivoting or other movement of element
17). Portions 21 can be removed by standard micro-fabrication removal procedures (e.g. a Bosch deep-
20 RIE silicon etch with an oxide etch mask) or by macro-fabrication methods (e.g. laser cutting). As can be seen in Fig. 13D, portions 23 (dotted line areas) can also be removed so as to separate the MEMS movable elements from each other. This provides for individual addressing if a common electrode is used. Removal of portions 23 also creates space for larger spacers 26 and adhesive/epoxy 27, for the addition of a sealing wafer 25 (see Fig. 13E). Wet or dry (plasma or non-plasma) etchants can be used
25 (for forming gaps 16 and removing portions 23), or combinations thereof, depending upon the material or combination of materials or layers in the upper wafer.

Unless wafer 1 is a reflective metallic wafer (e.g. Al), or is a wafer laminate made up of multiple wafers (one of which is reflective), or is a wafer previously coated with one or more metallic and/or reflective layers, then it may be desirable at this point to metalize at least movable element 17 with a
30 reflective layer (assuming the ultimate microstructure should have high reflectivity such as a micromirror in a projection display or optical switch). Metalization can be performed (with care to prevent shorting) by, e.g. using shadow-mask evaporation, though other metalization techniques are possible.

Sealing wafer 25 is bonded onto lower substrate wafer 5 by means of epoxy 27, and is held apart from lower wafer 5 and movable element 17 by means of spacers 26 (of larger size than spacers
35 10). Alternatively, portions 23 need not be removed, and additional spacers and epoxy could then be placed upon portions 23 or 24 of Fig. 13D, with the sealing wafer 25 added thereon. An intermediate wafer (with portions cut-out or etched corresponding to the position of the movable element) could be provided instead of spacers as long as the bonding method used for bonding the intermediate spacing wafer allows for removal of the sealing wafer after singulation.

5 If the sealing wafer is to be removed, it need not be of a light transmissive material, and can be non-permanently adhered (e.g. partially cured) onto the upper or lower wafer. The sealing wafer protects the movable elements and lower electrodes and circuitry during singulation (cutting of the wafers into arrays or individual optical beam steering devices). In one embodiment the sealing wafer is removed after singulation and replaced by a new cover bonded or glued in place at an angle to the other wafers (so
10 as to minimize surface reflections when used as a beam steering device in an optical switch). To facilitate cover removal, UV or IR cure glue can be used and run through the singulation (e.g. cutting or scribing) process without curing (or a small amount of curing) – the glue viscosity can be sufficient to prevent significant movement. The epoxy can then be cured after the sealing wafer is removed, and in one
15 embodiment, the same partially cured or uncured epoxy can be used to adhere the replacement substrate.

 Figure 13F shows the wafer assembly after singulation, which can be performed to result in cut edges 29. If the gap between the sealing wafer 25 and the first wafer 5 is large enough, a standard wafer saw can cut all the way through. Fig. 13G shows the assembly after removal of the sealing wafer. By
20 adding and removing the sealing wafer, the sensitive surface of the movable microstructures are protected by dust and debris during the singulation process. Also, such a method of forming an assembly of wafers as disclosed herein has a low thermal budget, which allow for the integration of silicon circuitry on the first wafer.

 The invention has been described in terms of specific embodiments. Nevertheless, persons familiar with the field will appreciate that many variations exist in light of the embodiments described
25 herein.

CLAIMS

We claim:

1. A method for forming a micromechanical device, comprising:
 - fully or partially forming one or more micromechanical structures multiple times on a first substrate;
 - bonding a second substrate onto the first substrate so as to cover the multiple areas each having one or more micromechanical structures, so as to form a substrate assembly;
 - separating the substrate assembly into individual dies, each die having the one or more micromechanical structures held on a portion of the first substrate, with a portion of the second substrate bonded to the first substrate portion; and
 - removing the second substrate portion from each die to expose the one or more micromechanical structures on the first substrate portion.
2. The method of claim 1, wherein after separating the substrate assembly into individual dies, providing an etchant so as to release the micromechanical structures.
3. The method of claim 1, wherein before bonding the second substrate to the first substrate, providing an etchant so as to release the micromechanical structures.
4. The method of claim 1, wherein a third substrate portion is provided after the second substrate portion is removed.
5. The method of claim 1, wherein the micromechanical structures are fully formed and released prior to bonding the second substrate onto the first substrate.
6. The method of claim 1, wherein the substrates are wafers.
7. The method of claim 6, wherein the micromechanical structures are microstructures that convert physical parameters to or from electrical signals.
8. The method of claim 7, wherein the microstructures are one or more micromirrors for data storage, optical switching or projection display.

9. The method of claim 7, wherein the microstructures are one or more accelerometers, DC relays, RF switches, beam splitters, filters, oscillators, variable capacitors, inductors, comb drives or resonant beams.
10. The method of claim 1, wherein the micromechanical structures are formed by surface and/or bulk micromachining.
11. The method of claim 10, wherein circuitry is formed with the micromechanical structures on the first substrate.
12. The method of claim 10, further comprising depositing a sacrificial layer on the first substrate, adding one or more structural layers, at least one of which connects to the first substrate, and removing the sacrificial layer to release the micromechanical structure.
13. The method of claim 12, wherein one of the structural layers is a metal layer for forming a reflective surface and wherein the micromechanical structure is a micromirror.
14. The method of claim 1, wherein the first substrate provided is a round or substantially round wafer of silicon, GaAs, glass or quartz.
15. The method of claim 12, wherein at least one of the one or more structural layers is a nitride, carbide or oxide of silicon deposited by chemical vapor deposition or sputtering.
16. The method of claim 12, wherein at least one of the one or more structural layers is polysilicon.
17. The method of claim 3, wherein the etchant is a vapor phase etchant selected from a noble gas fluoride, an interhalogen fluoride or vapor phase HF.
18. The method of claim 1, wherein the first and second substrates are bonded with epoxy or metal solder.
19. The method of claim 18, wherein a sacrificial material is provided adjacent the epoxy or metal solder.

20. The method of claim 19, wherein when the second substrate portion is removed after separation into dies, an etchant is provided that etches the sacrificial layer adjacent the epoxy or solder so as to detach the second substrate from the first substrate.
21. The method of claim 20, wherein the etchant detaches the second substrate portion from the first substrate portion and at the same time releases the micromechanical devices.
22. The method of claim 19, wherein a sacrificial material is applied in areas surrounding each die area, the size of the applied sacrificial material being larger than the size of solder or epoxy to be applied.
23. The method of claim 19, wherein the sacrificial material and epoxy or solder are applied to either or both of the first or second substrate.
24. The method of claim 1, further comprising forming circuitry on the first substrate.
25. The method of claim 24, wherein the circuitry is formed prior to forming the one or more micromechanical structures.
26. The method of claim 1, wherein the second substrate is a substantially planar substrate in the absence of circuitry or microstructures.
27. The method of claim 26, wherein the second substrate is substantially circular piece of glass.
28. The method of claim 25, wherein electrodes connected to the circuitry are formed beneath at least a portion of the micromechanical structures.
29. The method of claim 28, wherein the micromechanical structures are micromirrors in an array.
30. The method of claim 1, further comprising forming a plurality of circuit dies on a third substrate and separating the third substrate into a plurality of third substrate portions, each comprising circuitry.
31. The method of claim 30, further comprising aligning and bonding the third substrate portions to the first substrate portions after removal of the second substrate portions.

32. The method of claim 30, wherein the third substrate is a silicon or GaAs wafer.
33. The method of claim 1, wherein the micromechanical structures are fully formed and release prior to bonding the second substrate to the first substrate.
34. The method of claim 33, further comprising providing a stiction treatment after releasing the micromechanical structures.
35. The method of claim 34, wherein the stiction treatment comprises treating the micromechanical structures with a chlorosilane.
36. The method of claim 1, wherein the first and second substrates are wafers, the wafers bonded together with epoxy.
37. The method of claim 36, wherein the epoxy is a UV, IR or UV/IR epoxy.
38. The method of claim 37, wherein in the bonding step, the epoxy is uncured or partially cured.
39. The method of claim 38, wherein the first and second substrates are bonded in a spaced-apart relation with a gap therebetween of from 1 to 100 μm .
40. The method of claim 39, wherein the gap is greater than 20 μm .
41. The method of claim 39, wherein the gap is due to providing spacers between the first and second substrates.
42. The method of claim 41, wherein the spacers are mixed into the epoxy before application of the epoxy to one or both of the first and second substrates.
43. The method of claim 41, wherein the spacers are microfabricated spacers on the first substrate.
44. The method of claim 1, wherein separating the substrate assembly into individual dies comprises scoring, scribing or partially sawing one or both substrates followed by breaking the substrate assembly into individual dies.

45. The method of claim 44, further comprising applying a band of epoxy around substantially the entire circumference of the first or second substrate, applying beads or bands of epoxy adjacent each die area on the first or second substrate, pressing the two substrates together, and filling with epoxy any gaps in the circumferential band of epoxy.
46. The method of claim 45, further comprising partial wet sawing between individual dies, followed by breaking the substrate assembly into individual dies.
47. The method of claim 1, further comprising electrical testing of each die before removing the second substrate portion from each die.
48. The method of claim 1, wherein the second substrate portion is removed by insertion of a blade between the first substrate portion and the second substrate portion.
49. The method of claim 1, wherein cured epoxy remains on the second substrate portion and the micromechanical structures remain on the first substrate portion after removal of the second substrate portion.
50. The method of claim 1, wherein one or both of the first and second substrates is scored or partially sawed when initially provided, such that after bonding, the substrate assembly is broken along the score or saw lines so as to divide the substrate assembly into individual dies.
51. The method of claim 1, wherein the sealing substrate is a polymer wafer.
52. The method of claim 20, wherein the first and second substrates are held by vacuum chucks which pull the substrates apart while providing the etchant.
53. The method of claim 4, wherein the third substrate portion is glass.
54. The method of claim 53, wherein the glass has a light filtering or anti-reflection coating.
55. The method of claim 4, wherein the third substrate portion is bonded with epoxy.

56. The method of claim 55, wherein spacers are provided to maintain the third substrate portion at a fixed distance from the second substrate portion.
57. The method of claim 56, wherein the spacers are microfabricated spacers on the first or third substrate portion.
58. The method of claim 56, wherein the spacers are glass or polymer spacers mixed into the epoxy.
59. The method of claim 1, wherein after removing the second substrate portion, the first substrate portion with micromechanical structures is packaged.
60. The method of claim 59, wherein the packaging comprises a third substrate portion that covers and protects the first substrate micromechanical structures.
61. The method of claim 60, wherein the third substrate portion is connected to a frame but not directly to the first substrate portion.
62. The method of claim 4, wherein the third substrate comprises circuitry.
63. The method of claim 62, wherein the third substrate portion is formed by providing a third substrate, forming circuitry multiple times on the third substrate, and dividing the third substrate into multiple third substrate portions, each third substrate portion having circuitry thereon.
64. The method of claim 63, further comprising aligning the first and third substrates prior to bonding the first and third substrates together.
65. The method of claim 64, wherein the lateral alignment between the first and third substrates is within 5 μm .
66. The method of claim 64, wherein each third substrate portion further comprises multiple electrodes, and each first substrate portion comprises multiple movable micromirrors, the micromirrors and electrodes being aligned during alignment and bonding.
67. The method of claim 60, wherein the third substrate portion is display grade glass.

68. The method of claim 4, wherein the third substrate portion added is display grade glass and the first substrate portion is silicon and comprises circuitry, electrodes and micromirrors.
69. The method of claim 4, wherein the third substrate portion added is silicon and comprises circuitry and electrodes and the first substrate portion is glass and comprises micromirrors.
70. The method of claim 1, wherein prior to removing the second substrate portion:
wire bonding the first substrate portion to a lower package panel.
71. The method of claim 70, wherein prior to removing the second substrate portion and after wire bonding:
electrically testing the micromechanical structures on the first substrate portion by bringing an electrical probe into contact with electrical contacts on the lower package panel.
72. The method of claim 71, further comprising bonding an upper package panel directly or indirectly to the lower package panel in order to encapsulate the micromechanical structures on the first substrate portion.
73. The method of claim 1, wherein prior to removing the second substrate portion:
electrically testing the micromechanical structures on the first substrate portion by bringing an electrical probe into contact with electrical contacts on the first and/or second substrate portions.
74. The method of claim 73, wherein prior to removing the second substrate portion and after electrically testing the micromechanical structures:
electrically connecting the first substrate portion to a portion of packaging for the micromechanical device.
75. The method of claim 74, wherein the portion of the packaging is a lower package panel on which the first substrate portion is bonded.
76. The method of claim 75, further comprising bonding an upper package panel directly or indirectly to the lower package panel in order to encapsulate the micromechanical structures on the first substrate portion.

77. The method of claim 1, further comprising, prior to separating the substrate assembly into individual dies, releasing the micromechanical structures with an etchant, and optically testing the released micromechanical structures.
78. The method of claim 73, wherein the electrical testing comprises moving one micromechanical structure or a group of micromechanical structures on the first wafer portion and optically monitoring movement of the one or more structures.
79. The method of claim 78, wherein the micromechanical structures are an array of micromirrors.
80. The method of claim 1, wherein the forming of one or more micromechanical structures comprises forming MOS-type circuitry and released micromechanical structures.
81. The method of claim 1, wherein the bonding of the second substrate onto the first substrate is by anodic bonding.
82. The method of claim 1, wherein the bonding of the second substrate onto the first substrate is by metal eutectic bonding.
83. The method of claim 1, wherein the bonding of the second substrate onto the first substrate is by fusion bonding.
84. The method of claim 12, wherein the sacrificial material is silicon.
85. The method of claim 84, wherein the sacrificial material is amorphous silicon.
86. The method of claim 12, wherein the sacrificial layer is a polymer.
87. The method of claim 86, wherein the sacrificial layer is polyimide.
88. The method of claim 84, wherein the sacrificial material is removed with xenon difluoride.
89. The method of claim 12, wherein after removal of the sacrificial layer, an anti-stiction material is added.

90. The method of claim 89, wherein the anti-stiction material is deposited from a silane precursor.
91. A method for forming a plurality of micromirror arrays comprising micromirrors, the method comprising:
forming micromirror arrays multiple times on a first substrate;
bonding a second substrate onto the first substrate so as to cover the multiple areas each having a micromirror array, so as to form a substrate assembly;
separating the substrate assembly into individual dies, each die having a micromirror array on a portion of the first substrate with a portion of the second substrate bonded to the first substrate portion; and
removing the second substrate portion from each die to expose the one or more micromechanical structures on the first substrate portion.
92. The method of claim 91, wherein after separating the substrate assembly into individual dies, providing an etchant so as to release the micromirrors.
93. The method of claim 91, wherein before bonding the second substrate to the first substrate, providing an etchant so as to release the micromirrors.
94. The method of claim 91, wherein a third substrate portion is provided after the second substrate portion is removed.
95. The method of claim 91, wherein the micromirrors are fully formed, released and treated with an anti-stiction material prior to bonding the second substrate onto the first substrate.
96. The method of claim 91, wherein the substrates are wafers.
97. The method of claim 96, wherein the micromirrors are pixels for a projection display.
98. The method of claim 97, wherein the microstructures are one or more micromirrors for data storage, optical switching or projection display.
99. The method of claim 97, wherein the micromirrors are formed of a laminate of insulating and conductive materials.

100. The method of claim 100, wherein circuitry is formed with the micromirrors on the first substrate.
101. A method for forming a micromechanical device, comprising:
forming one or more micromechanical structures in one or more areas on a first substrate;
bonding caps onto the first substrate so as to cover the one or more areas each having one or more micromechanical structures, so as to form a substrate assembly;
after a period of time, removing the caps to expose the one or more micromechanical structures.
102. The method of claim 101, wherein during said period of time, the substrate assembly is singulated, inspected, irradiated, annealed, die attached, shipped and/or stored.
103. The method of claim 102, wherein during said period of time, the substrate assembly is inspected, the inspection comprising testing the micromechanical devices.
104. The method of claim 101, wherein during said period of time, the substrate assembly is singulated.
105. The method of claim 101, wherein during said period of time, the substrate assembly is irradiated.
106. The method of claim 101, wherein during said period of time, the substrate assembly is annealed.
107. The method of claim 101, wherein during said period of time, the substrate assembly is shipped.
108. The method of claim 101, wherein during said period of time, the substrate assembly is stored.
109. The method of claim 101, wherein during said period of time, the substrate assembly is die attached into a package.
110. The method of claim 109, further comprising connecting a light transmissive window onto the package after die attach.

111. The method of claim 101, wherein the micromechanical structures are released with an etchant prior to bonding caps onto the first substrate.
112. The method of claim 101, wherein the first substrate is a silicon wafer.
113. The method of claim 101, wherein the microstructures are micromirrors for optical switching or projection displays.
114. The method of claim 101, wherein the microstructures are accelerometers, microrelays, or RF switches.
115. The method of claim 101, wherein circuitry is formed with the micromechanical structures on the first substrate.
116. The method of claim 115, wherein circuitry and electrodes are provided on the first substrate, and wherein the micromechanical structures are micromirrors.
117. The method of claim 111, wherein the micromechanical structures are released with an etchant is a vapor phase chemical etchant.
118. The method of claim 117, wherein the etchant is selected from HF, noble gas halides or interhalogens.
119. The method of claim 118, wherein the etchant is xenon difluoride.
120. The method of claim 101, further comprising depositing a sacrificial layer on the first substrate, adding one or more structural layers, at least one of which connects to the first substrate, and removing the sacrificial layer to release the micromechanical structure.
121. The method of claim 120, wherein the sacrificial layer is a polymer.
122. The method of claim 121, wherein the polymer is polyimide.
123. The method of claim 101, wherein the caps are bonded by anodic bonding.

- 124. The method of claim 101, wherein the caps are bonded by fusion bonding.
- 125. The method of claim 101, wherein the caps are bonding by metal eutectic bonding.
- 126. The method of claim 101, wherein the caps are bonded with an adhesive.
- 127. The method of claim 126, wherein the adhesive is an epoxy.
- 128. The method of claim 120, wherein after releasing the micromechanical structure, an anti-stiction material is added.
- 129. The method of claim 128, wherein the anti-stiction material is deposited from a silane precursor.

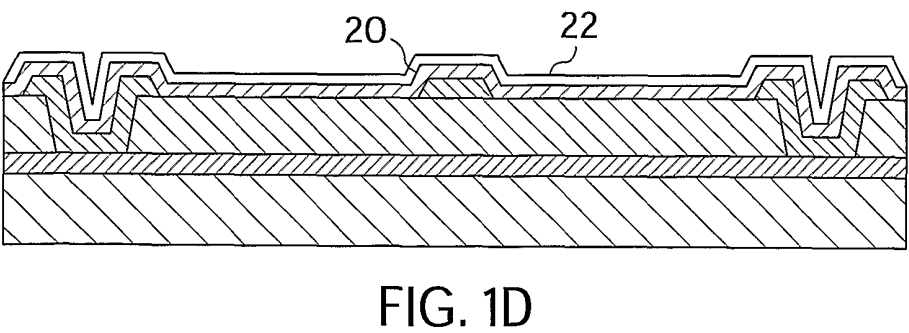
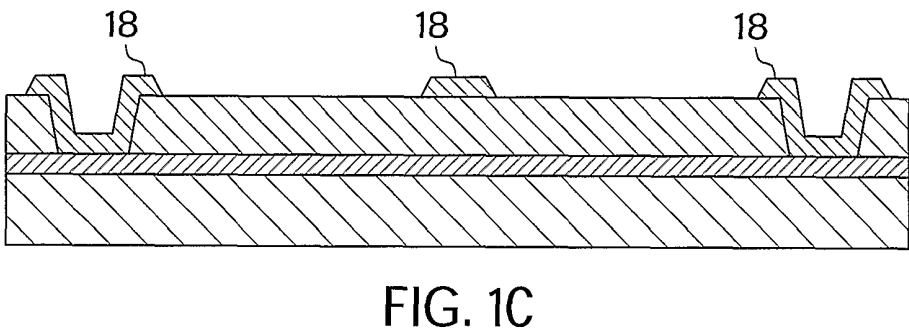
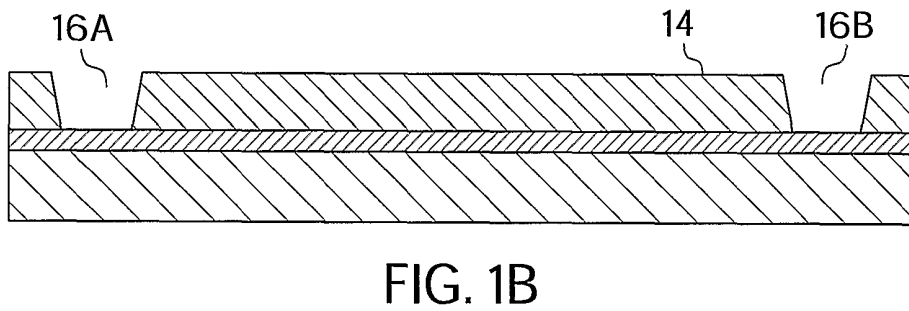
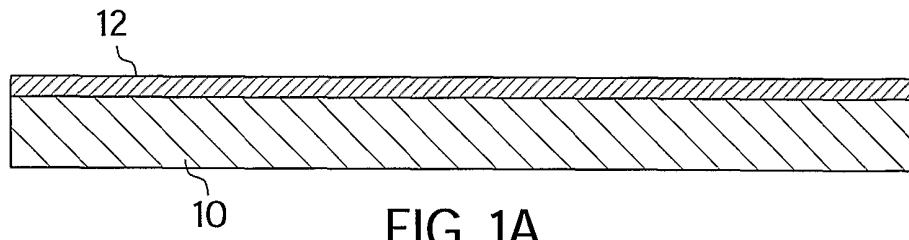

2 / 17

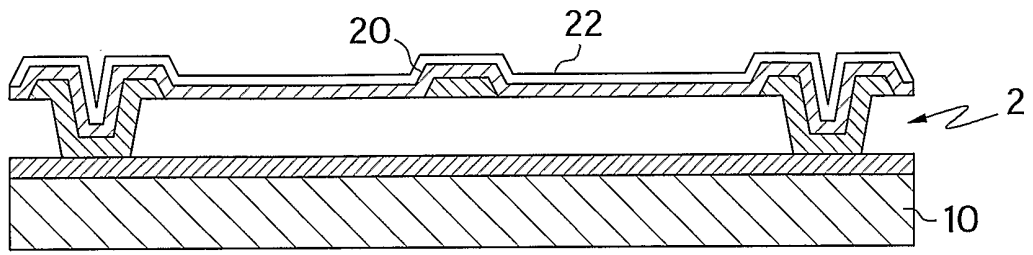

FIG. 1E

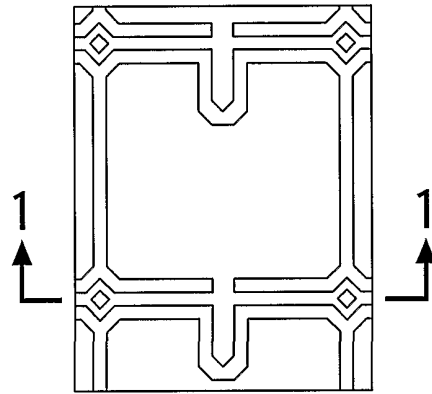

FIG. 2

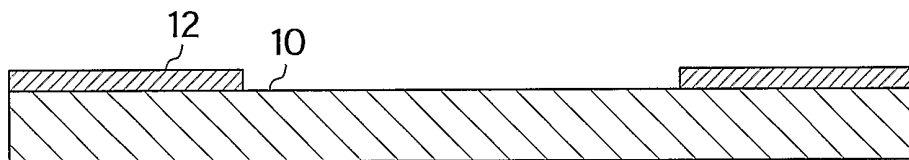

FIG. 3A

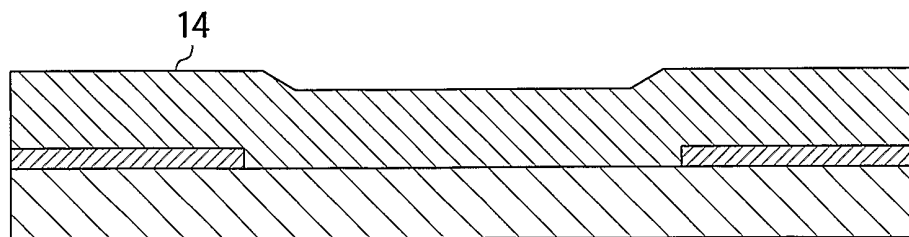

FIG. 3B

3 / 17

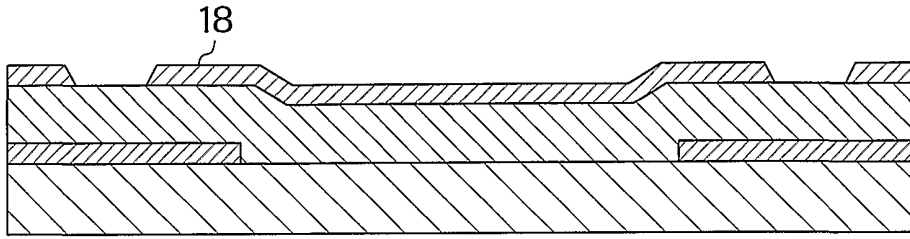

FIG. 3C

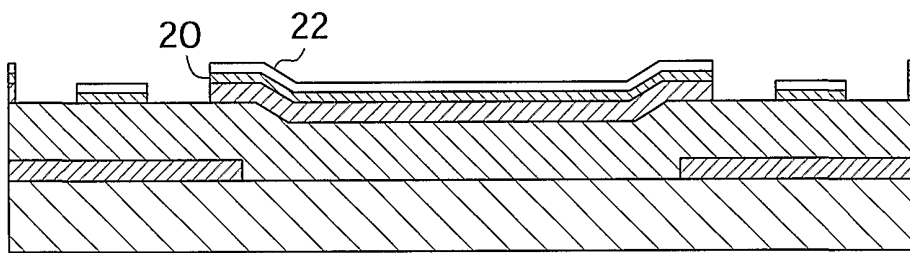

FIG. 3D

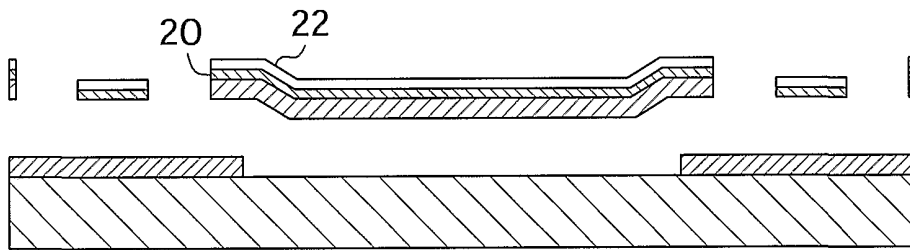

FIG. 3E

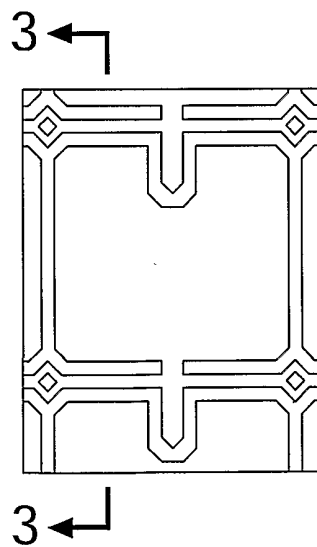

FIG. 4

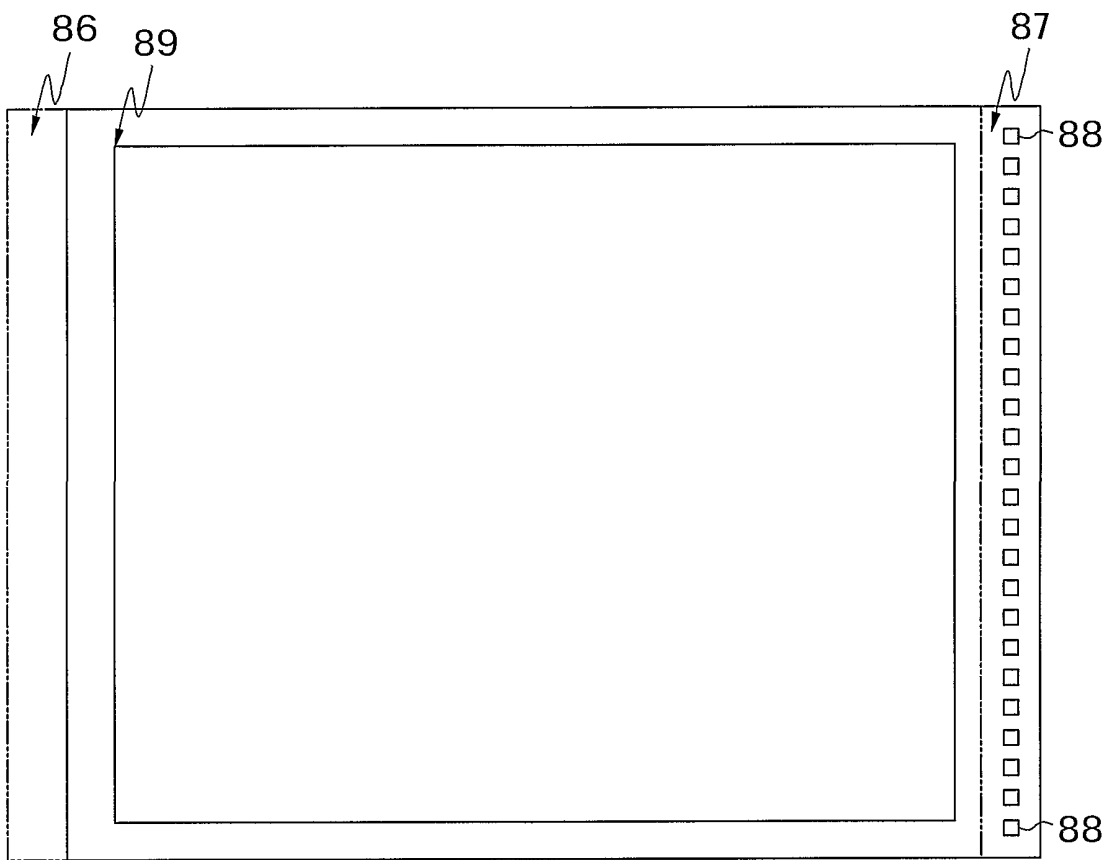

FIG. 5

5 / 17

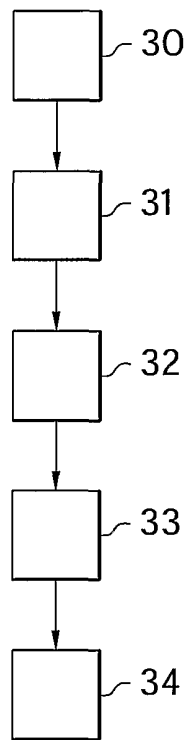

FIG. 6

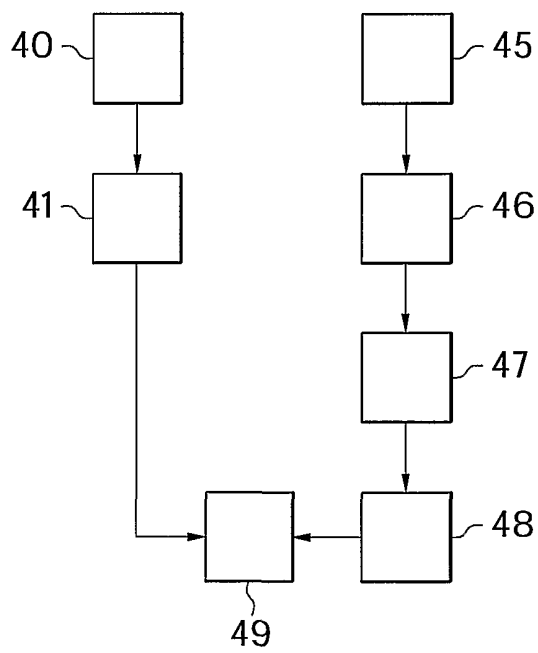

FIG. 7

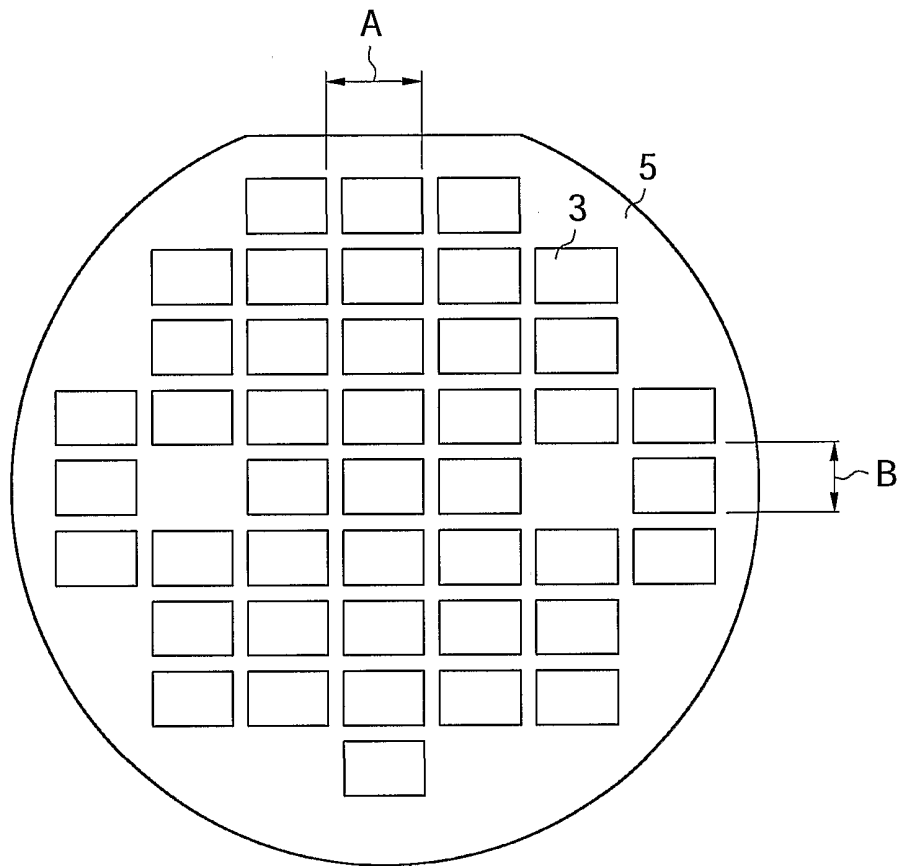

FIG. 8

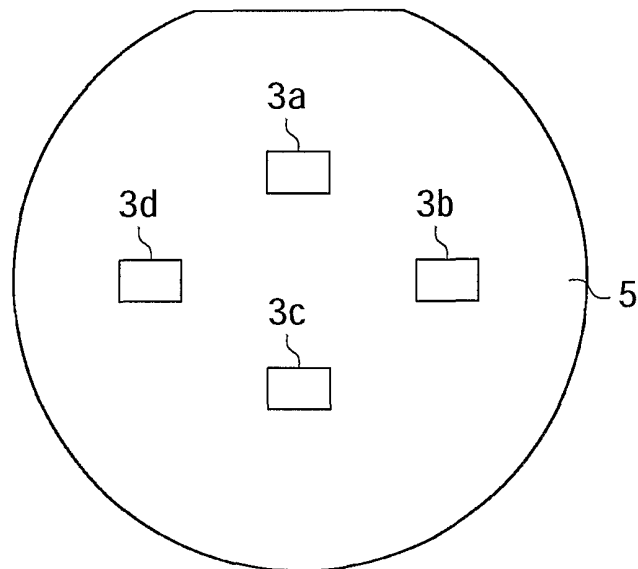

FIG. 9A

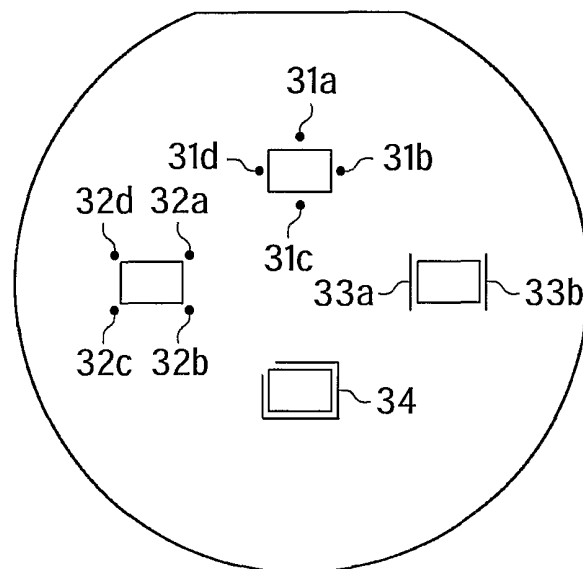

FIG. 9B

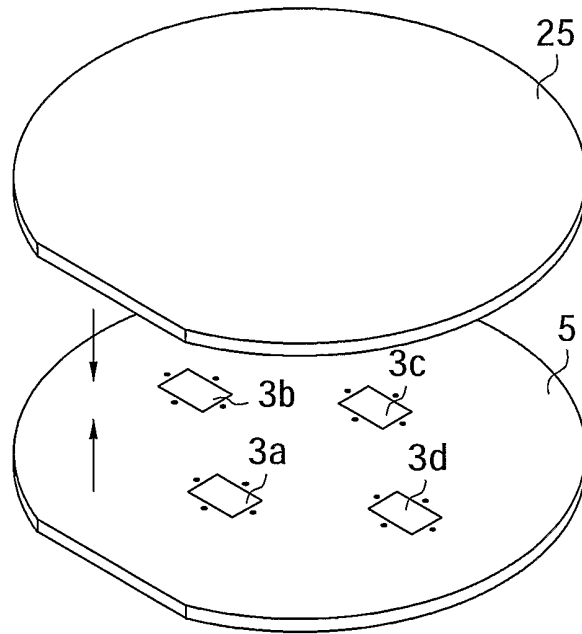

FIG. 9C

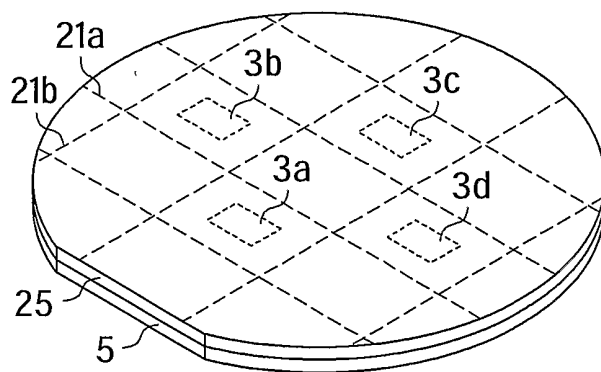

FIG. 9D

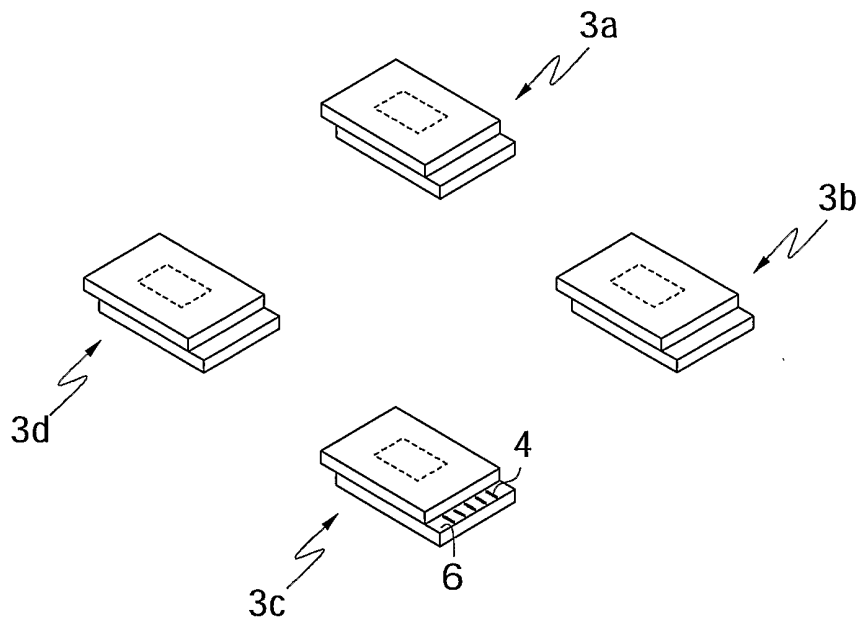

FIG. 9E

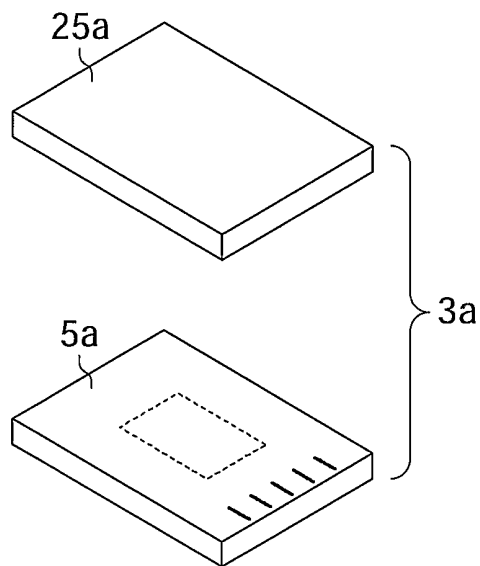

FIG. 9F

10 / 17

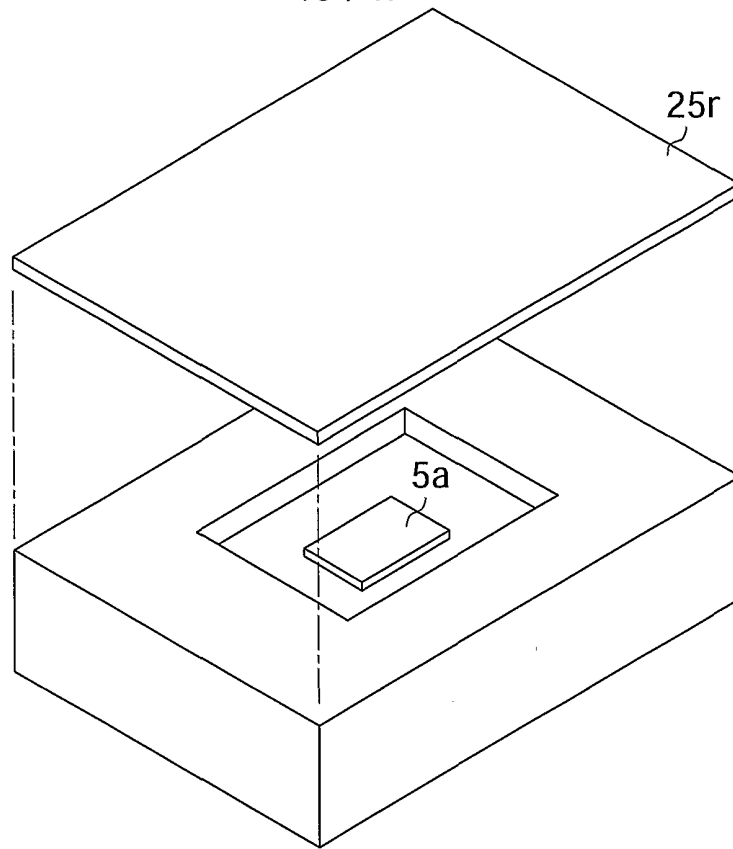

FIG. 9G

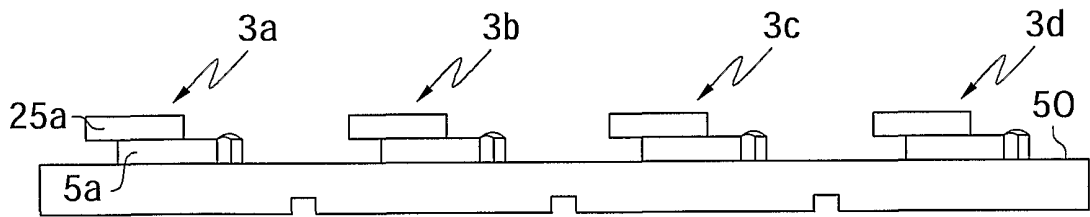

FIG. 10A

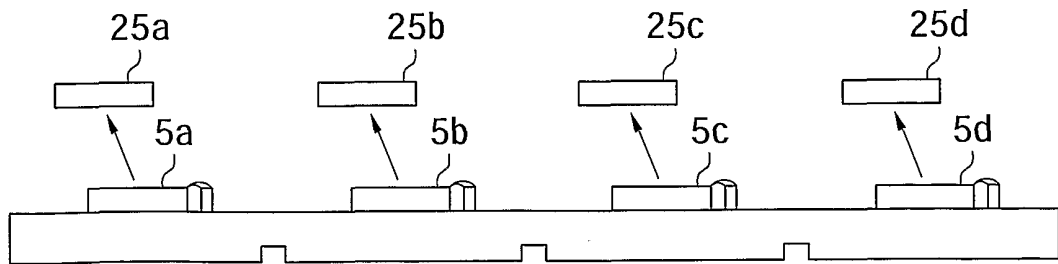

FIG. 10B

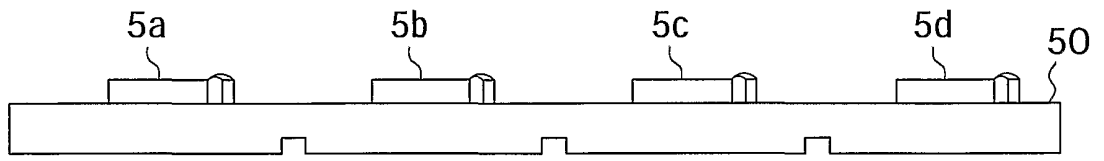

FIG. 10C

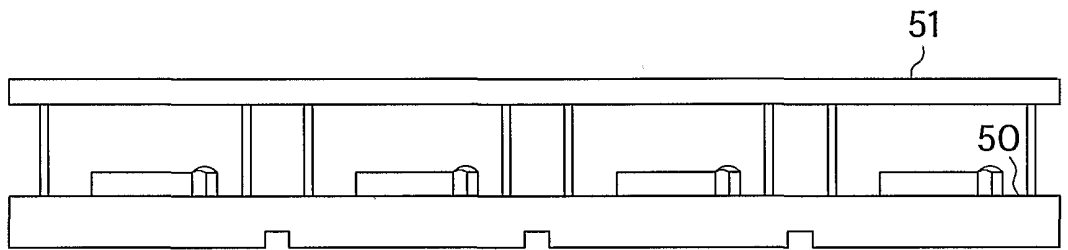

FIG. 10D

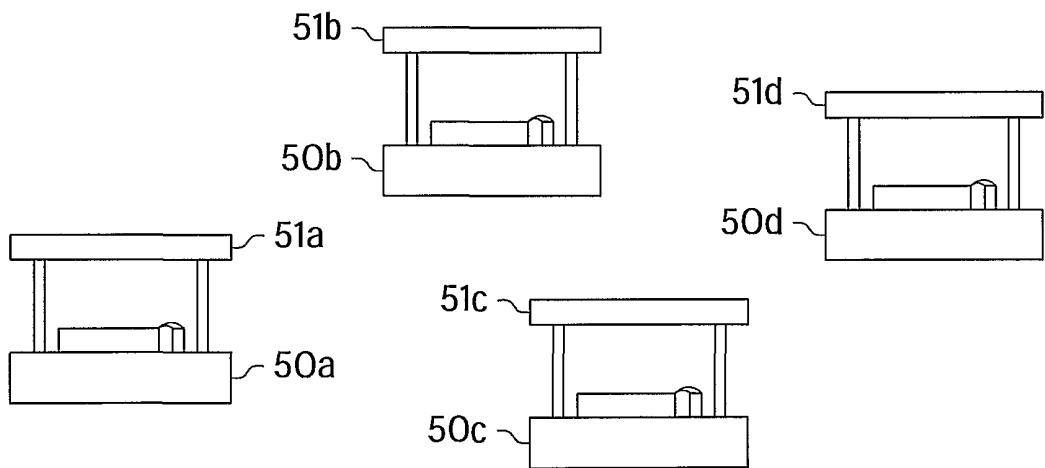

FIG. 10E

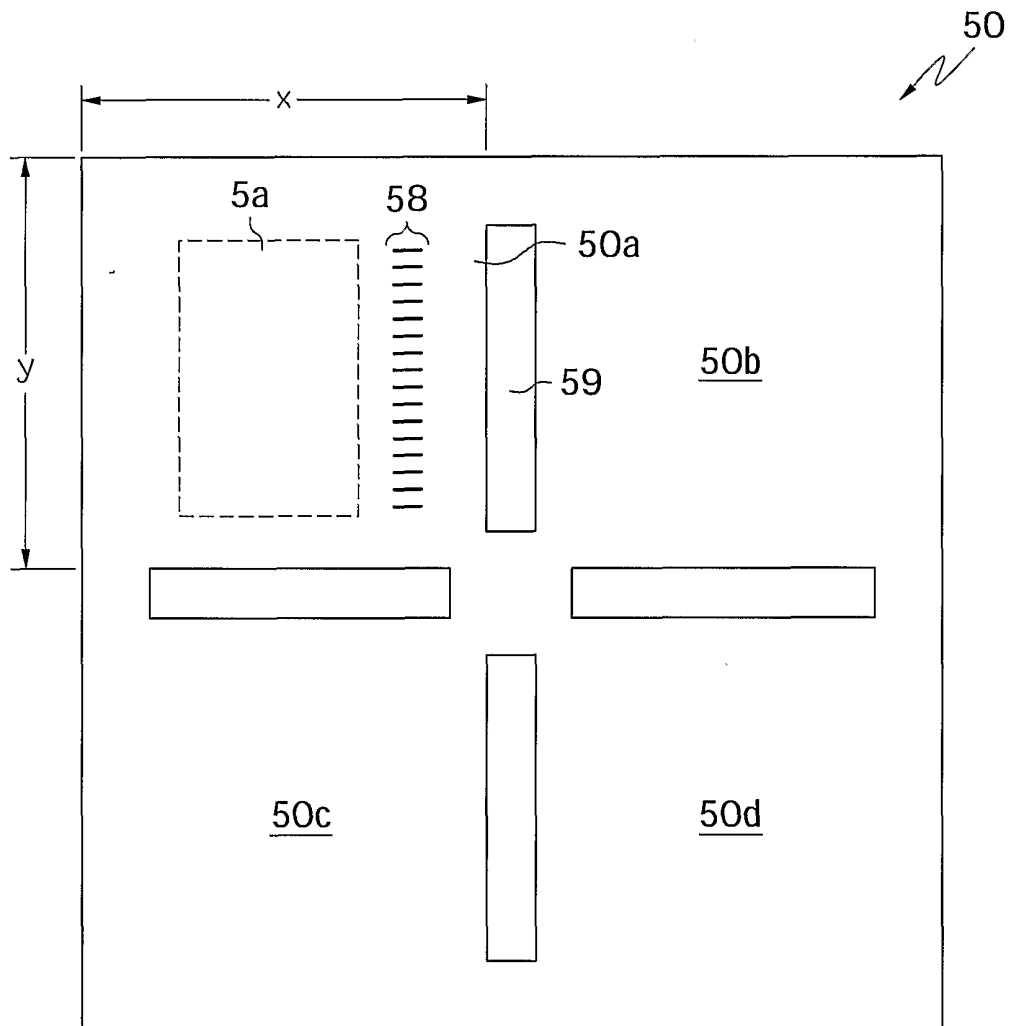

FIG. 10F

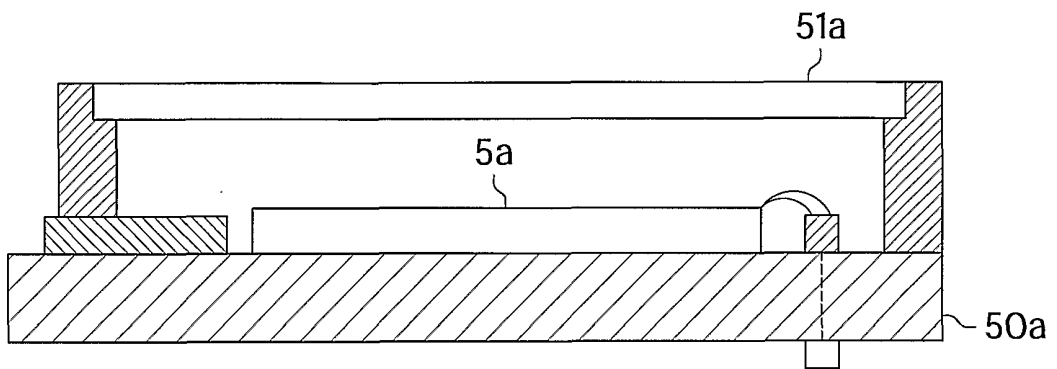

FIG. 10G

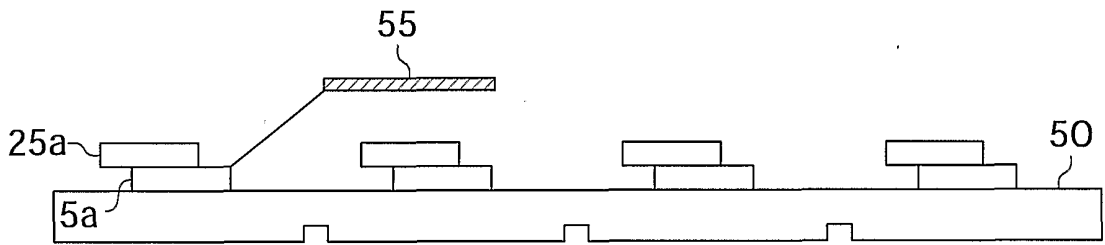

FIG. 11A

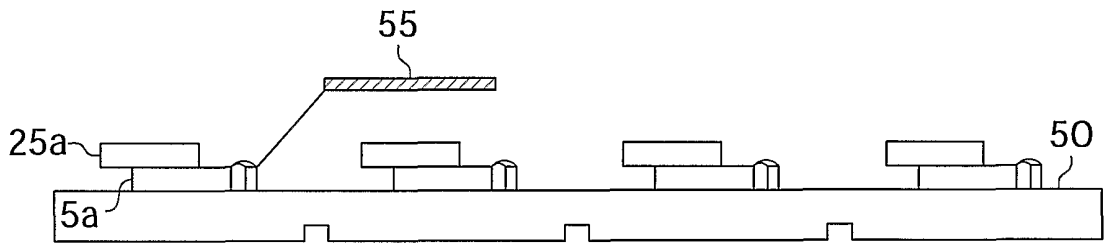

FIG. 11B

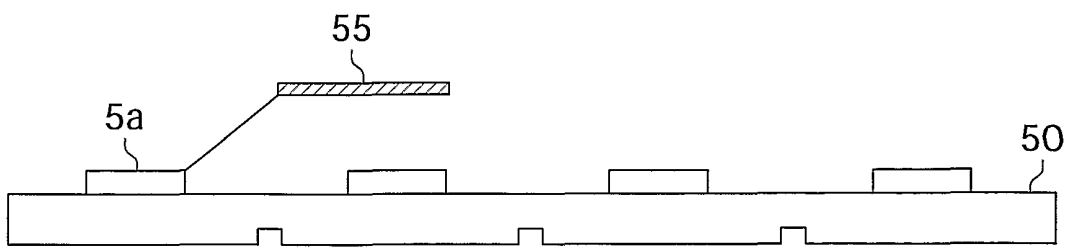

FIG. 11C

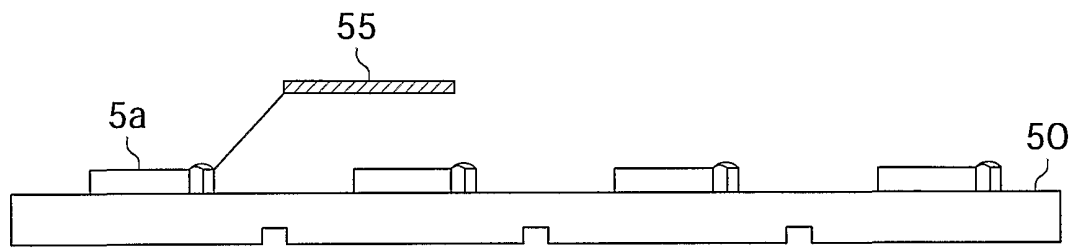

FIG. 11D

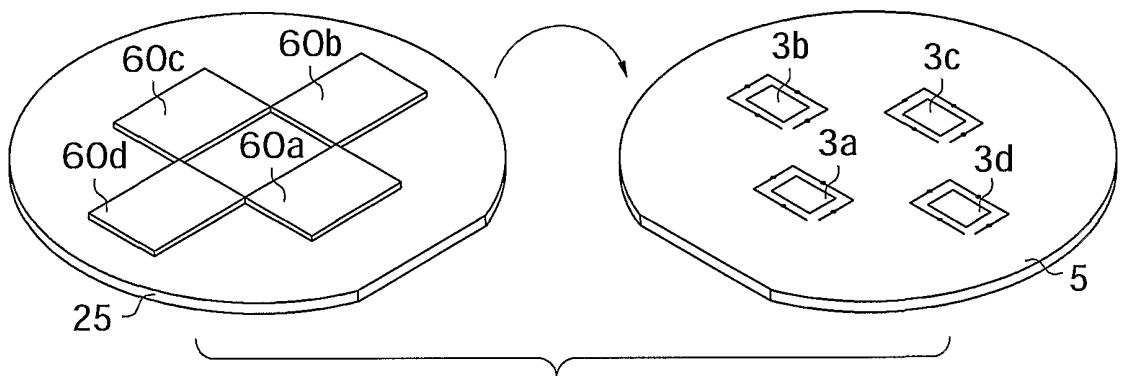

FIG. 12A

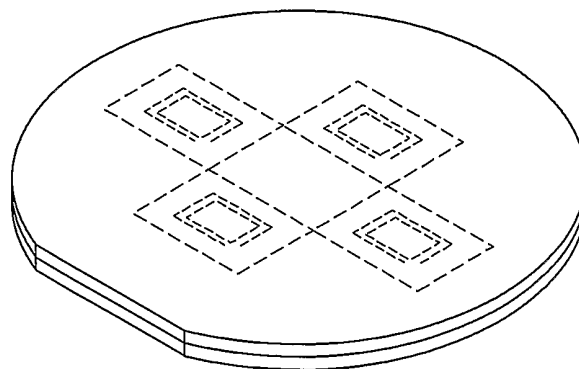

FIG. 12B

15 / 17

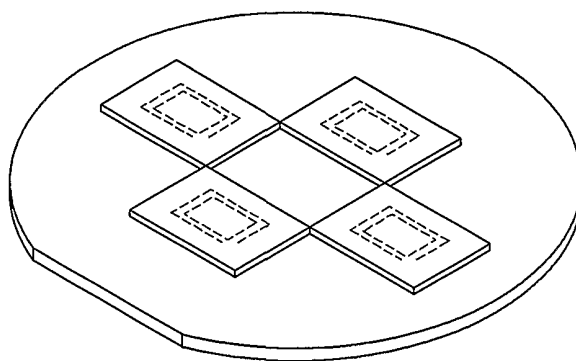

FIG. 12C

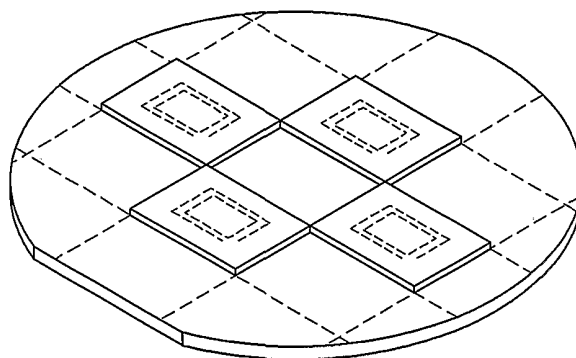
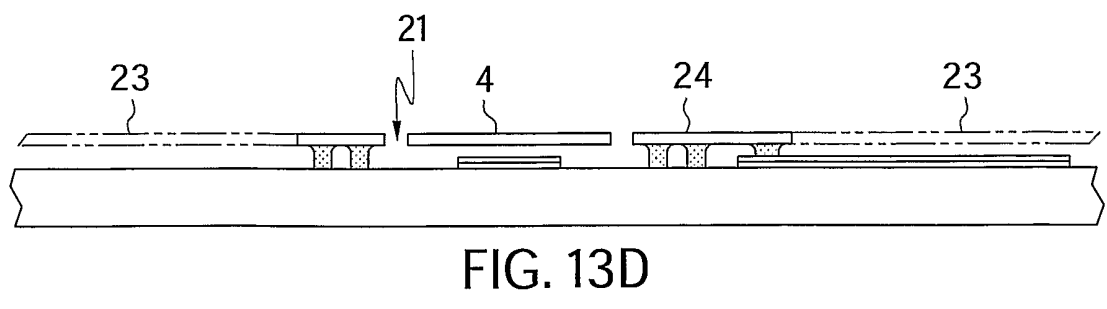
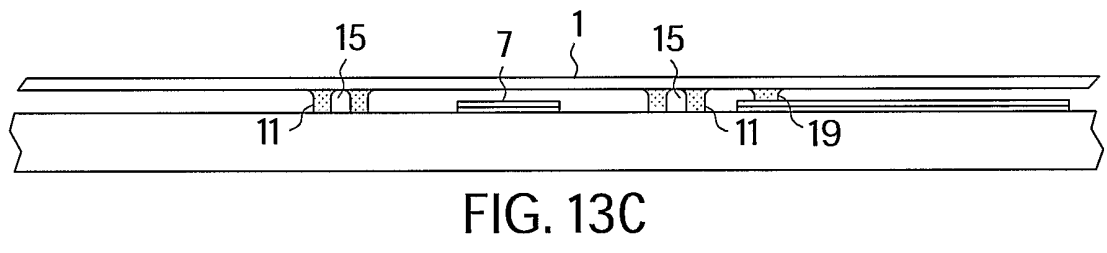
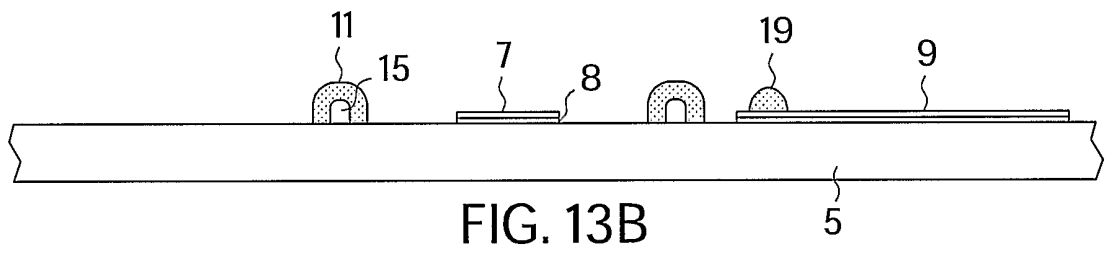
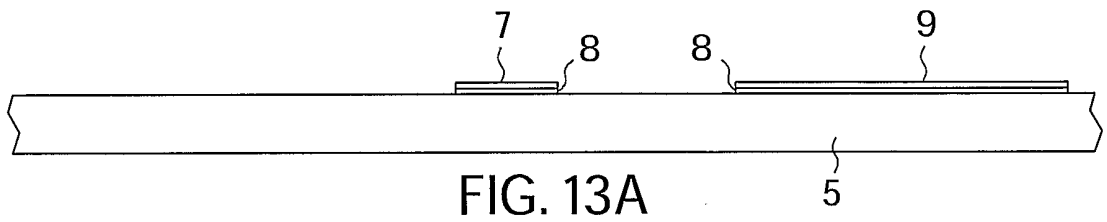

FIG. 12D



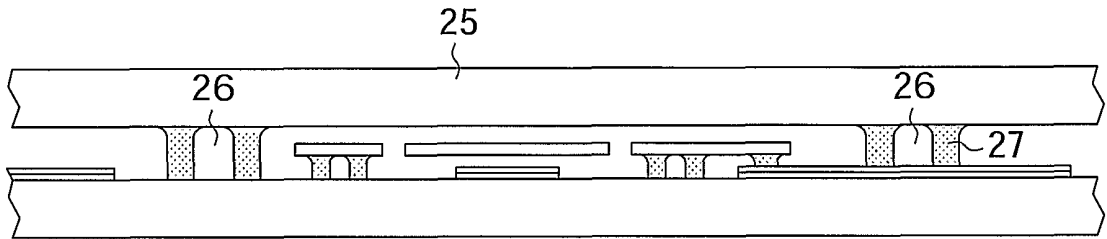

FIG. 13E

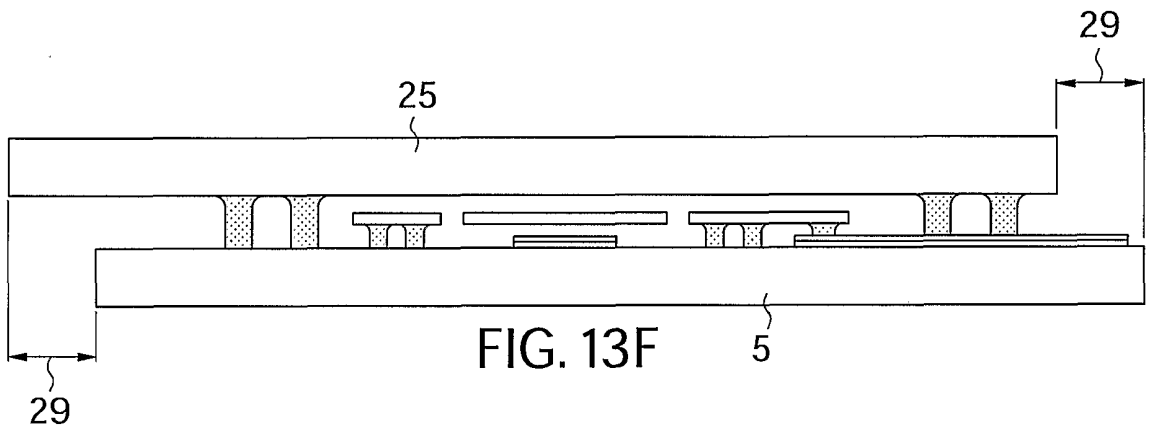

FIG. 13F

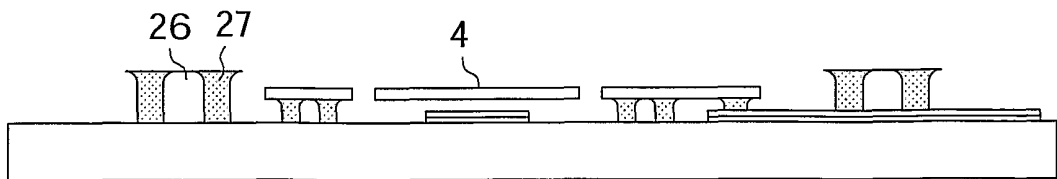

FIG. 13G