

19



Europäisches Patentamt
European Patent Office
Office européen des brevets



11 Publication number:

0 337 429 B1

12

EUROPEAN PATENT SPECIFICATION

15 Date of publication of patent specification: 07.07.93 51 Int. Cl.⁵: **B41J 2/14**

21 Application number: **89106516.1**

22 Date of filing: **12.04.89**

54 Ink jet head.

30 Priority: 12.04.88 JP 89372/88
03.06.88 JP 137888/88
23.06.88 JP 155891/88

43 Date of publication of application:
18.10.89 Bulletin 89/42

45 Publication of the grant of the patent:
07.07.93 Bulletin 93/27

64 Designated Contracting States:
DE FR GB

66 References cited:
DE-A- 3 028 404
US-A- 4 072 959
US-A- 4 564 851

PATENT ABSTRACTS OF JAPAN vol. 12,
no.21 (M-661)(2868), 22 January 1988; JP-
A-62 179 948

73 Proprietor: **SEIKO EPSON CORPORATION**
4-1, Nishishinjuku 2-chome
Shinjuku-ku Tokyo-to(JP)

72 Inventor: **Kitahara, Tsuyoshi c/o Selko Epson Corporation**
3-5, Owa 3-chome

Suwa-shi Nagano-ken(JP)
Inventor: **Yonekubo, Shuji c/o Selko Epson Corporation**
3-5, Owa 3-chome
Suwa-shi Nagano-ken(JP)
Inventor: **Morozumi, Hideki c/o Selko Epson Corporation**
3-5, Owa 3-chome
Suwa-shi Nagano-ken(JP)
Inventor: **Higashimura, Koichi c/o Selko Epson Corporation**
3-5, Owa 3-chome
Suwa-shi Nagano-ken(JP)
Inventor: **Matsuzawa, Masanao c/o Selko Epson Corporation**
3-5, Owa 3-chome
Suwa-shi Nagano-ken(JP)

74 Representative: **Hoffmann, Eckart Patentanwalt Blumbach & Partner et al**
Bahnhofstrasse 103
W-8032 Gräfenberg (DE)

EP 0 337 429 B1

Note: Within nine months from the publication of the mention of the grant of the European patent, any person may give notice to the European Patent Office of opposition to the European patent granted. Notice of opposition shall be filed in a written reasoned statement. It shall not be deemed to have been filed until the opposition fee has been paid (Art. 99(1) European patent convention).

Description

The present invention relates to an ink jet recording apparatus for forming an ink image on a medium such as recording paper or the like by ejecting ink droplets onto the medium. More particularly, the present invention relates to the ink jet head of such an ink jet recording apparatus.

An ink jet head according to the prior art portion of claim 1 having a substrate in which a plurality of nozzles are formed and a piezoelectric transducer for pressurizing and ejecting ink is disclosed in US-A-4,072,959. In this prior art ink jet head, vibrators forming the piezoelectric transducer are displaced almost rectangularly to the nozzle forming substrate so that the ink passage to the nozzles is short and the discharge efficiency and stability of ink droplets are high. Further, since the ink passages between the nozzles communicate with each other at a short distance, bubbles and foreign matters like dust and the like which may be mixed in the ink will not influence the normal operation.

The vibrators, being of a cantilever or center beam structure, provide a high electro-mechanical transducing efficiency and allow to achieve the necessary vibrator displacement by a low voltage.

On the other hand, stable characteristics are hard to obtain with the aforementioned prior art. The size of a gap between each vibrator and the nozzle forming substrate influences characteristics like the ejection rate, the ejection quantity and the ejection recover time. Therefore, in order to obtain satisfying characteristics, the gap size must be controlled with a very small tolerance. To increase the ejection rate and the ejection quantity of the ink droplets it is necessary to keep the gap between the nozzle forming substrate and the vibrator disposed opposite to it within an infinitesimal constant range, so as to increase the pressure of the ink existing near to the nozzles. However, in such infinitesimal gap, a great flow induced resistance due to a flow of the ink existing in the gap between the vibrator and the nozzle forming substrate, opposes the vibrator displacement. Also, it is difficult to set a proper damping condition of the vibrators, and thus, for example, if the damping is excessive, the maximum value of the ink ejection pressure is minimized and the time required for reaching the maximum ejection pressure becomes long compared to the case of a lower periodic damping with a long time constant, thus deteriorating the energy efficiency. Moreover, the feed of the ink necessary for restoring a nozzle meniscus for the next ink ejection is hindered by the small gap between the vibrator and the nozzle forming substrate, so that the time for ink return becomes long deteriorating the recover time and making a phenomenon of an

ejection quantity fluctuation unavoidable, depending on the driving frequency.

The present invention is intended to remedy the above mentioned problems and to realize an ink jet head having a high energy efficiency and stable characteristics while providing a good ejection rate, ejection quantity and ejection recover time of the ink droplets at the same time.

This object is achieved with an ink jet head as claimed.

With this solution, when the vibrator is deformed and displaced to eject ink, an ejection pressure generation characteristic and a periodic damping characteristic depending on the flow resistance acting on the ink existing between the nozzle forming substrate and the vibrator moving part, can be controlled independently from each other, thus allowing to realize a head with stable characteristics.

Embodiments of the present invention will be described in detail below with reference to the drawings, wherein:

Fig. 1

is a perspective view of an embodiment of a recording apparatus with an ink jet head according to the invention,

Fig. 2

is a perspective view illustrating the construction of a piezoelectric transducer used in a first embodiment of the ink jet head according to the invention,

Figs. 3(a) and (3b)

are a front view and a sectional view, respectively, illustrating the shape of a nozzle forming substrate of the first embodiment of the invention,

Fig. 4

is a partial sectional view showing the construction of the ink jet head of the first embodiment of the invention,

Fig. 5

is a drawing for illustrating the pressure generation mechanism,

Figs. 6(a), (b) to Figs. 9(a), (b)

are drawings showing various alternative shapes of the nozzle forming substrate,

Fig. 10

is a sectional view of a second embodiment of the ink jet head of the invention,

Fig. 11

is a perspective view illustrating the construction of the piezoelectric transducer of the second embodiment,

Fig. 12

is a partial sectional view of a third embodiment of the ink jet head of the invention,

Fig. 13

is a sectional view of a fourth embodiment of the

ink jet head of the invention,

Fig. 14

is a perspective view illustrating the construction of the piezoelectric transducer used in the fourth embodiment,

Fig. 15

is a drawing showing the shape of the vibrator used for a fifth embodiment of the invention,

Fig. 16

is a partial sectional view of the fifth embodiment of the ink jet head of the invention,

Figs. 17(a), (b) to Figs. 19(a), (b)

are drawings showing various alternative shapes of the vibrator used for the fifth embodiment,

Figs. 20(a) and (b)

are drawings representing a sixth embodiment of the invention, wherein

(a) shows the shape of a nozzle forming substrate and

(b) indicates the relation between the nozzle forming substrate and the vibrator,

Figs. 21(a) and (b)

are drawings representing a seventh embodiment of the invention, wherein

(a) shows the shape of a nozzle forming substrate and

(b) indicates the relation between the nozzle forming substrate and the vibrator, and

Fig. 22

is a drawing for explaining a process for manufacturing the nozzle forming substrate of the sixth embodiment.

Example 1

Fig. 1 illustrates one embodiment of a recording apparatus having an ink jet head according to the invention mounted thereon. A recording medium 1 is wound around a platen 4 under the pressure of feed rollers 2 and 3, and is fed in the direction indicated by an arrow 5 during the recording. An ink jet head 9 is mounted on a carriage 8 shiftable in the direction of an arrow 10 parallel to the platen 4 along guide shafts 6, 7. The ink jet head 9 has a plurality of nozzles (not shown in Fig. 1) which can be independently controlled to eject ink droplets. The ink jet head 9 is moved in the direction of an arrow 10 while ink droplets are selectively ejected by its nozzles, and thereby an ink image is formed on the recording medium 1.

Fig. 2 is a perspective view showing the construction of a piezoelectric transducer that can be used in the ink jet head of the present invention. The transducer 20 comprises a plurality of vibrators 21, separated by cuts 23 from each other, and a fixed portion 22. Signal electrodes 25 consisting of an Au thin layer are formed on one side of respective piezoelectric elements 24 consisting of PZT. A

metallic plate consisting of an Ni layer is formed as a common electrode 26 on the other side of the piezoelectric elements 24. A spacer 27 consisting of an Ni layer is formed on the fixed portion 22.

Fig. 3(a) is a front view illustrating the shape of a nozzle forming substrate of the present invention. Fig. 3(b) is a sectional view of the nozzle forming portion along line A-A in Fig. 3(a). The nozzle forming substrate 30 is made of an Ni thin plate having a plurality of nozzles 31 formed by electroforming. Portions other than a belt-like portion linking neighboring portions of nozzle inlet openings 34 are removed by etching. A level difference is thus provided forming a bed 32 in the neighborhood of the nozzle inlet openings 34 of the nozzle forming substrate.

Fig. 4 is a partial sectional view showing the construction of the ink jet head 9 according to the first embodiment of the present invention. The nozzle forming substrate 30, the piezoelectric transducer 20 and an elastic seat 42 are arranged between a main frame 40 and a subframe 41. The subframe 41 has an ink reservoir 43 formed therein and ink (not indicated) is fed from the ink reservoir 43 to the nozzles 31. The direction into which the piezoelectric element 24 is polarized is such that the direction of contraction is orthogonal to the electric field established when a voltage is applied between the common electrode 26 and the signal electrode 25. Since the Ni thin layer forming the common electrode 26 has a high elastic modulus, when an electric field is applied to the piezoelectric element, a bending moment is generated toward the signal electrode 25 resulting in a corresponding deformation. Therefore, when a voltage is applied in standby condition and selectively removed, the free end of the vibrator 21 is deformed and displaced towards the nozzle forming substrate 30 to eject ink through the nozzle 31. A gap a between the vibrator 21 and the nozzle 31 is dimensioned so as to obtain a better ink ejection characteristic, and a gap b between the vibrator 21 and the portions of the substrate 30 other than the bed 32 of the nozzle inlet openings 34 (Fig. 3(a)) is set so as to operate the vibrator in a proper periodic damping range in order to achieve a smooth feed of ink.

With reference to Fig. 5 the pressure generation mechanism and damping mechanism will now be explained in further detail. As a simple model, when two disks approach each other at a constant velocity as shown in Fig. 5, the pressure built up between the two disks will be given approximately by the following equation:

$$P = \frac{3nV}{h^3} (X^2 + Z^2 - a^2)$$

where

- η : fluid viscosity
 V: velocity of one disk relative to the other
 P: pressure
 h: distance between the disks
 2a: diameter of each disk
 X and Z are variables as defined in Fig. 5

A peak pressure is generated near the center of the disk and no pressure is generated at the peripheral edge portion. The value of the pressure depends largely on the distance h between the disks.

Accordingly, in the case of a beam vibrator as in the first embodiment, it is necessary to control the gap between the nozzle forming substrate in the neighborhood of the nozzles and the vibrator to an appropriate value in order to establish a high pressure at the nozzle portion and obtain an efficient ink ejection. If this gap is excessively small, the resistance of the ink flow to the nozzles increases and the ink will not be fed satisfactorily. Referring to Fig. 4, that means that the dimension a must be controlled to an appropriate value. The gap between the nozzle forming substrate and the vibrator (dimension b in Fig. 4) in the area other than the neighborhood of the nozzles does not influence the pressure generation. If the area where the gap has the dimension a in Fig. 4 is larger than necessary, the ink flow to the nozzles will be affected. Tests have been conducted with various sizes of vibrators and fluids of different viscosities, and the ink ejection characteristic has been evaluated. It was found that the area of the gap with the dimension a should have a width not greater than that of the vibrator. Designating the vibrator width as B (Fig. 2), if the area of the gap keeping the dimension a (this will be referred to as the first area in the following) is expressed by a radius C from the nozzle center, then the relation should be $C \leq B/2$. The remaining area of the gap (second area) other than the first area defined by B/2 does not influence the pressure generation at the nozzle portion. Accordingly, from the viewpoint of ejection pressure generation, an efficient ejection may be realized by controlling voids in the neighborhood of the nozzles and also controlling voids in other areas independently from each other. The gap in the second area will be set so as to control the flow resistance and mass load acting on the vibrator by the ink flow caused by a displacement of the vibrator. Thereby, an appropriate periodic damping characteristic of the vibrator can be set. If the gap is larger than an appropriate value, a residual vibration inhibits a high-speed response and further, a plurality of ink droplets are ejected upon a single driving signal (displacement of the vibrator). If the gap is smaller than the appropriate value, then the

flow resistance load will become excessive and a large power will be required for the displacement. It was found experimentally that the flow resistance load in the second area must be decreased if the ink viscosity is more than 5mPas, and thus $a < b$ is preferable. If the ink viscosity is 5mPas or less, it is desirable that an appropriate flow resistance load be provided in the second area, and thus $a > b$ will be preferable.

The first embodiment concerns the former case, where the ink viscosity is set to 8mPas, the vibrator width to 0.3 mm, gap dimension a to 20 μ m, gap dimension b to 40 μ m and the dimension C of the bed area to 25 mm.

Figs. 6(a), (b) to 9(a), (b) are front views illustrating various shapes of the nozzle forming substrate for the ink jet head according to the invention, and sectional views along lines B-B, C-C, D-D, E-E, respectively. The shapes shown in Fig. 6 are intended to enhance the ink feed to the nozzles from all circumferential directions by giving a circular shape to the bed 32 of a nearby portion to the inlet opening 34 of each nozzle 31 as compared to the belt-like bed 32 shown in Fig. 3(a). The arrangements shown in Figs. 7 to 9 differ from that shown in Fig. 6 in that grooves 33 are provided to extend radially from the nozzle center, thereby further enhancing the ink feed. The bottom of the grooves 33 is on the same plane as the remaining portions other than the bed 32. In particular, Figs. 7 and 9 are effective in reducing the mutual influence among the nozzles, since grooves 33 are not provided in portions of the bed 32 opposing adjacent nozzles.

In the construction explained above, the thickness of the spacer 27 and the height of the bed 32 will be set appropriately in order to select desired gap dimensions a and b. In order that the vibrators 21 are operated with an appropriate damping, the gap for feeding ink necessary for restoring a nozzle meniscus after ejection of ink droplets is determined by the gap dimension b near to the fixed end of the vibrators. The gap necessary for ejecting ink droplets is determined by the gap dimension a near to the free end of the vibrators. By that an efficient ink jet head having high energy efficiency and satisfying various characteristics such as ejection rate, ejection quantity and ejection recover time at the same time is obtained.

As explained above, in this embodiment a metallic thin plate integrally formed with the piezoelectric element is used as the spacer. However, a separate metallic thin plate may be inserted and fixed between the nozzle forming substrate and the piezoelectric element as the spacer. Further, a cantilever beam type vibrator has been described. However, a similar construction is also realizable with a center beam type vibrator.

In the embodiment described above, the area of the nozzle inlet opening 34 is wider than that of the outlet opening and thus, the nozzle is horn-like in section. However, the nozzle shape is not particularly limited to this specific shape and it is apparent that other shapes may be employed for the nozzle in the invention.

Example 2

Fig. 10 shows another embodiment of the ink jet head using a vibrator form different from that of the previous embodiment. The basic construction is similar to the foregoing embodiment and thus, the following description will concentrate on the differences.

In Fig. 10, a vibrator 52 is disposed opposite to each nozzle 53 through an infinitesimal gap a near to its free end. A wiring 55 is connected to signal electrodes 54 to selectively apply a voltage to the vibrators.

The construction of the piezoelectric transducer 56 is shown in Fig. 11. In this embodiment, different from the embodiment shown in Fig. 2, each vibrator has a gap controlling layer 57 on a front nose portion.

Example 3

Fig. 12 shows a partial sectional view of a third embodiment of the ink jet head according to the invention. A nozzle forming substrate 60 comprises a metallic thin plate having a plurality of nozzles 61 formed therein and a portion around the nozzle opposite to the free end of a vibrator 62 is formed to be thicker than other portions. A vibrator 62 is disposed opposite to each nozzle 61 through an infinitesimal gap a near to the free end of the vibrator.

In this embodiment, a groove 64 is formed in a portion of the nozzle forming substrate 60 opposite to the neighborhood of a fixed end of the vibrator 62. Accordingly, the gap b in the neighborhood of the fixed end of the vibrator and the gap a in the neighborhood of the free end of the vibrator are determined by the thickness of a spacer 65 and the depth of the groove 64. Again, the gap b is determined to obtain a desired periodic damping of the vibrator 62 and the gap a to obtain the necessary ink ejection.

Example 4

Fig. 13 is a sectional view of the ink jet head according to a fourth embodiment of the invention. A nozzle forming plate 72, a spacer 73, a piezoelectric transducer 74 and an elastic seat 75 are arranged between a main frame 70 and a subframe

71, fixed together by means of setscrews 76, 77. The nozzle forming plate 72 comprises a metallic thin plate having a plurality of nozzles 78 formed therein. A heater 79 is mounted on the rear side of the subframe 71 and used to heat the ink jet head up to a working temperature and to dissolve a hot-melt ink (not shown) filled in an ink reservoir 80 and around the piezoelectric transducer 74. The ink has a solid state at room temperature.

Fig. 14 is a perspective view of the piezoelectric transducer 74. It comprises a plurality of vibrators 81, separated by cuts and a fixed portion 82. A piezoelectric element 83 consisting of PZT has a signal electrode 84 consisting of an Au thin layer on one side and a common electrode 85 consisting of an Ni thin layer on the other side. The piezoelectric element 83 and the common electrode 85 are joined together by means of a solder (having a fusing point of 140°C) at a temperature of 160°C which is higher than the aforementioned working temperature. Since the coefficient of linear expansion of Ni constituting the common electrode 85 is greater than that of the piezoelectric element 83, a bending moment of a bimetal effect is generated at a working temperature of 110°C, and thus a dished warp with a curvature R^{-1} is produced on the common electrode side (this condition is shown in Fig. 14). The coefficients of linear expansion of the piezoelectric element and Ni used in this embodiment are $1.8 \times 10^{-6} K^{-1}$ and $12.8 \times 10^{-6} K^{-1}$, respectively. When the span of the cantilever beam is 3 mm, a dished warp with a curvature $R^{-1} = 6.0 m^{-1}$ and a radius of curvature $R = 166.7 mm$ is produced by a temperature difference of 50°C, and a warp $y = 27 \mu m$ (Fig. 13) is obtained. In Fig. 13, the piezoelectric transducer 74 is tightly fixed on the nozzle plate so as to keep the tangent of the fixed end of the vibrator 81 in parallel with the nozzle plate 72. The free end of the vibrator 81 is disposed opposite to a corresponding nozzle 78 through an infinitesimal gap near the free end, which is produced by the warp. The piezoelectric transducer 74 has its fixed end clamped between the main frame 70 and the subframe 71 through the spacer 73 and the elastic seat 75. The piezoelectric transducer 74 thus remains flat in this area and an internal stress is generated as a consequence. The vibrator is designed with a relatively short fixed end so that the internal stress does not exceed a permissible range, and thereby a damage of the vibrator is prevented.

A wiring 86 is connected to the individual signal electrodes 84 in order to selectively energize the vibrators. The common electrodes 85 are independently formed on each vibrator and electrically connected with each other by using Ni for the spacer 73 and an Al or Zn die casting for the main frame 70.

The operation of this embodiment of the invention will be explained next with reference to Fig. 13. A hot-melt ink is fed around the nozzles from the ink reservoir 80. As with the foregoing embodiment, applying voltage to the vibrator the nose of the vibrator is displaced and ink ejected from the nozzle 78.

In the above described construction, the gap b for setting an appropriate periodic damping of the vibrator 81 is determined by the thickness of the spacer 73. A warp γ is produced on the free end of the vibrator 81 according to the bimetal effect explained above. Therefore, the gap a between the nozzle and the neighborhood of the free end of the vibrator, necessary for ejecting ink is secured by clamping the fixed end of the vibrator 81 onto the nozzle forming plate 72 through the spacer 73. Thus, when an electrical signal is impressed on the vibrator, it reaches a final displacement under a periodic damping of a long time constant. Therefore, the ink ejection pressure can be maximized and the time for arriving at the maximum ejection pressure can be shortened. Further, even if a member having a different coefficient of linear expansion is provided on the vibrator, since the working temperature is controlled by using a hot-melt ink, a fluctuation of the warp according to the bimetal effect due a change of the environmental temperature can be prevented.

Example 5

Fig. 15(a) shows a portion of a vibrator 90 of the piezoelectric transducer of a fifth embodiment of the invention. Fig. 15(a) shows the side of a vibrator portion facing the nozzle forming substrate. Fig. 15(b) is a sectional view taken on line F-F in Fig. 15(a). The piezoelectric transducer of this embodiment comprises a plurality of vibrators 90 and a fixed portion. A signal electrode 92 consisting of an Au thin layer is formed on one side of a piezoelectric element 91, and a metallic plate consisting of an Ni layer and serving as a common electrode 93 is formed on the other side of the piezoelectric element 91. The metallic plate has on the free end of the vibrator 90 opposite to a nozzle a thickened portion forming a circular projection 94.

Fig. 16 is a partial sectional view illustrating the construction of the ink jet head according to the fifth embodiment of the invention. The gap a between the projection 94 provided on the vibrator 90 and a nozzle forming substrate 95 is sized to enhance the ink droplet ejection characteristic. The gap b between the portion other than the projection 94 of the vibrator 90, and the nozzle forming substrate 95 is set independently of the gap a such that the vibrator is operated with an appropriate periodic damping and ink is fed smoothly from all

circumferential directions to the nozzles.

Fig. 17(a), (b) to Fig. 19(a), (b) are drawings corresponding to Fig. 15(a), (b) and showing alternative constructions of the vibrators. According to Figs. 17 to 19, grooves 96 are provided in the circular projection 94 in order to further enhance the ink feed. The grooves 96 extend radially from the nozzle center and their bottom is on the same plane as the portions other than the projection 94. In particular, the alternatives shown in Figs. 17 and 19 are not provided with grooves 96 on both sides facing to adjacent vibrators, thereby to decrease a mutual influence between the nozzles.

Example 6

Figs. 20(a) and (b) are a front view and a sectional view, respectively, showing the shape of the nozzle forming substrate of a sixth embodiment of the present invention. This embodiment is suitable for a case where the viscosity of the ink is low, and the relation between the width a of the gap in the first area near to the nozzle and the width b of the gap in the remaining area is set to a $>$ b. Since the basic construction is similar to the foregoing embodiments, no further description will be given here. The nozzle forming substrate 100 is manufactured by electroforming and hence is constructed generally with a uniform thickness.

As shown in Fig. 22, an electrolytically plated layer 203 is formed on a master having a conductor pattern 202 formed on an insulator 201. The layer 203 is coated with a resist layer 204 and an electrolytically plated layer 205 is further formed on portions of the layer 202 exposed through patterning. Thus, after finally removing the resist layer 204, a die having a desired nozzle hole and a suitable level difference is obtained by electroforming. An electrolytically plated layer is formed on the die and thereafter removed from the die to obtain the stepped nozzle forming substrate shown in Fig. 20. When assembled, this nozzle forming substrate results in a gap of width a in a first area and a gap of width b in the remaining second area between the nozzle forming substrate and the vibrator. As to the extension of the first area, reference is made to the description of Figs. 3 to 5.

Example 7

Figs. 21(a), (b) are a front view and a sectional view, similar to Figs. 20(a), (b), showing the relation between the vibrator and the nozzle forming substrate of a seventh embodiment. In Figs. 21(a), (b) the same reference numerals as in Figs. 20(a), (b) are used. Like the sixth embodiment, the seventh embodiment is intended for the case where the viscosity of the ink is low. In a circular shaped first

area of radius c in the neighborhood of the nozzle, the nozzle forming substrate has a recess resulting in a gap width a which is larger than the gap width b in the remaining area of the gap between the nozzle forming substrate and the vibrator.

As described above, the gap between the nozzle forming substrate and the vibrator is divided into a first area near to a nozzle inlet opening of the nozzle forming substrate and a remaining second area. The gap width in the first area is different from that in the second area. The width a of the gap in the first area has a value necessary for the ink ejection. The gap width b in the second area providing a feed passage for the ink is selected so as to allow a quick restoration of a nozzle meniscus after ejection of an ink droplet. Thus, the time for the ink to be refilled is controlled to a proper value. Thereby, the recover time can be shortened while keeping the ink droplet ejection rate and the ejection quantity at desired values. Thus, the present invention provides an ink jet head superior in performance by improving various characteristics such as ink droplet ejection rate, ejection quantity, ejection recover time and ejection stability and the like at the same time.

Further, since the gap width between the vibrator and the nozzle forming substrate in the said second area can be set to a value allowing the vibrator to operate in an appropriate periodic damping range, the energy consumption due to the viscosity of the ink existing in the gap between the vibrator and the nozzle forming substrate will be decreased allowing an operation at a relatively low driving voltage. Since the gap width of the first area and the second area can be set independently, a margin for setting each width will be expanded, thereby enhancing the production yield.

Claims

1. An ink jet head for an ink jet recording apparatus, having a nozzle forming substrate (30) in which a plurality of nozzles (31) are formed, and a piezoelectric transducer (20) comprising a plurality of vibrators (21), each having at least one end fixed, disposed opposite to a corresponding nozzle (31) and drivable independently from each other, a gap being formed between the nozzle forming substrate (30) and the vibrators (21) and filled with ink, the width (a) of the gap in a first area near to and around said nozzles (31) being different from the width (b) of the gap in a remaining second area, characterized in that said first area has a length from the position of a nozzle (31) toward said fixed vibrator end, corresponding to half or less than half the

width (B) of said vibrators (21).

2. The ink jet head according to claim 1, wherein the width (a) of the gap in said first area is smaller than that (b) in the second area, when the viscosity of the ink is more than 5mPas, and that the width (a) of the gap in said first area is larger than that (b) of said second area, when the viscosity of the ink is 5mPas or less.

Patentansprüche

1. Tintenstrahlkopf für ein Tintenstrahlzeichnungsgerät mit einem düsenbildenden Substrat (30), in dem eine Vielzahl von Düsen (31) ausgebildet ist, und einem piezoelektrischen Wandler (20), der eine Vielzahl von Vibratoren mit jeweils wenigstens einem fixierten Ende aufweist, welche einer jeweiligen Düse (31) gegenüberliegend angeordnet und unabhängig voneinander ansteuerbar sind, wobei ein mit Tinte gefüllter Spalt zwischen dem düsenbildenden Substrat (30) und den Vibratoren (21) ausgebildet ist und die Breite (a) des Spalts in einem ersten Bereich nahe den Düsen (31) und um diese herum verschieden von der Breite (b) des Spalts in einem restlichen zweiten Bereich ist, dadurch gekennzeichnet, daß der erste Bereich eine Länge von der Position einer Düse (31) in Richtung auf das fixierte Vibratorende aufweist, die der Hälfte oder weniger als der Hälfte der Breite (b) der Vibratoren (21) ist.
2. Tintenstrahlkopf nach Anspruch 1, bei dem die Breite (a) des Spalts in dem ersten Bereich kleiner als die (b) in dem zweiten Bereich ist, wenn die Viskosität der Tinte mehr als 5 mPas beträgt, und daß die Breite (a) des Spalts in dem ersten Bereich größer als die (b) des zweiten Bereichs ist, wenn die Viskosität der Tinte 5 mPas oder weniger beträgt.

Revendications

1. Une tête à jet d'encre pour un appareil d'enregistrement à jet d'encre comportant un substrat de formation de buses (30) dans lequel un ensemble de buses (31) sont formées, et un transducteur piézoélectrique (20) comprenant un ensemble de vibreurs (20), ayant chacun au moins une extrémité fixe, qui sont disposés face à une buse correspondante (31) et qui peuvent être actionnés indépendamment les uns des autres, un intervalle étant formé entre le substrat de formation de buses (30) et les vibreurs (21), et cet intervalle étant rempli par de l'encre,

la largeur (a) de l'intervalle dans une première région proche des buses (31) et entourant ces dernières, étant différente de la largeur (b) de l'intervalle dans une seconde région restante,

5

caractérisée en ce que

la première région a une longueur, depuis la position d'une buse (31), vers l'extrémité de vibrateur fixe, qui correspond à la moitié ou à moins de la moitié de la largeur (B) des vibrateurs (21).

10

2. La tête à jet d'encre selon la revendication 1, dans laquelle la largeur (a) de l'intervalle dans la première région est inférieure à la largeur (b) dans la seconde région, lorsque la viscosité de l'encre est supérieure à 5 mPa.s, et la largeur (a) de l'intervalle dans la première région est supérieure à la largeur (b) dans la seconde région lorsque la viscosité de l'encre est inférieure ou égale à 5 mPa.s.

15

20

25

30

35

40

45

50

55

8

FIG. 1

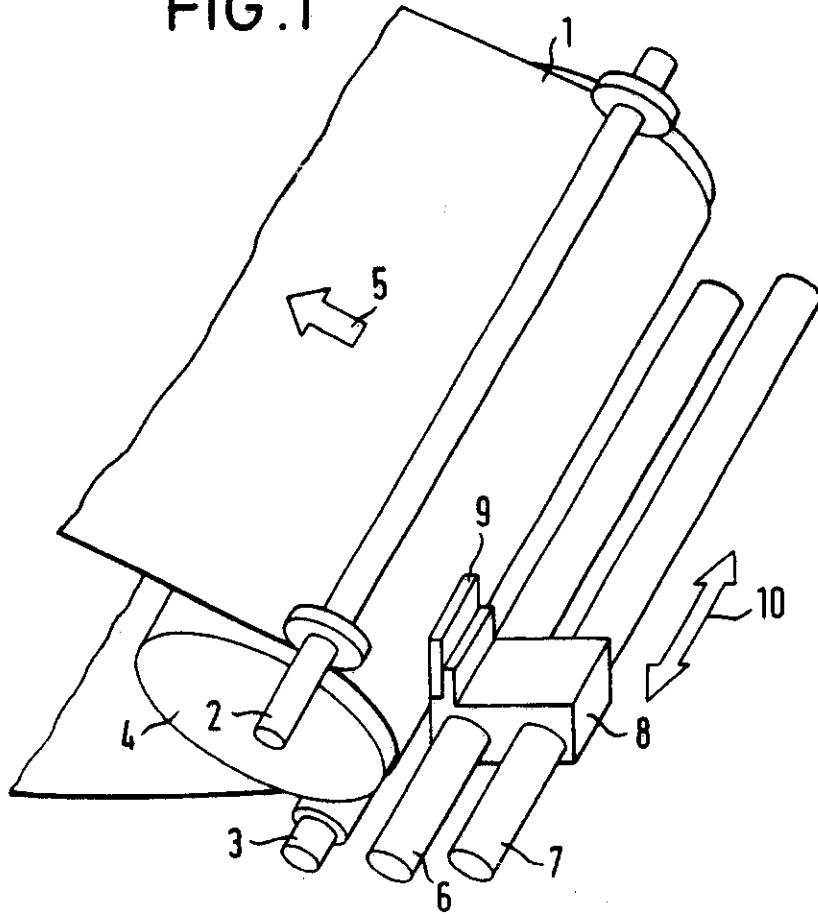

FIG. 2

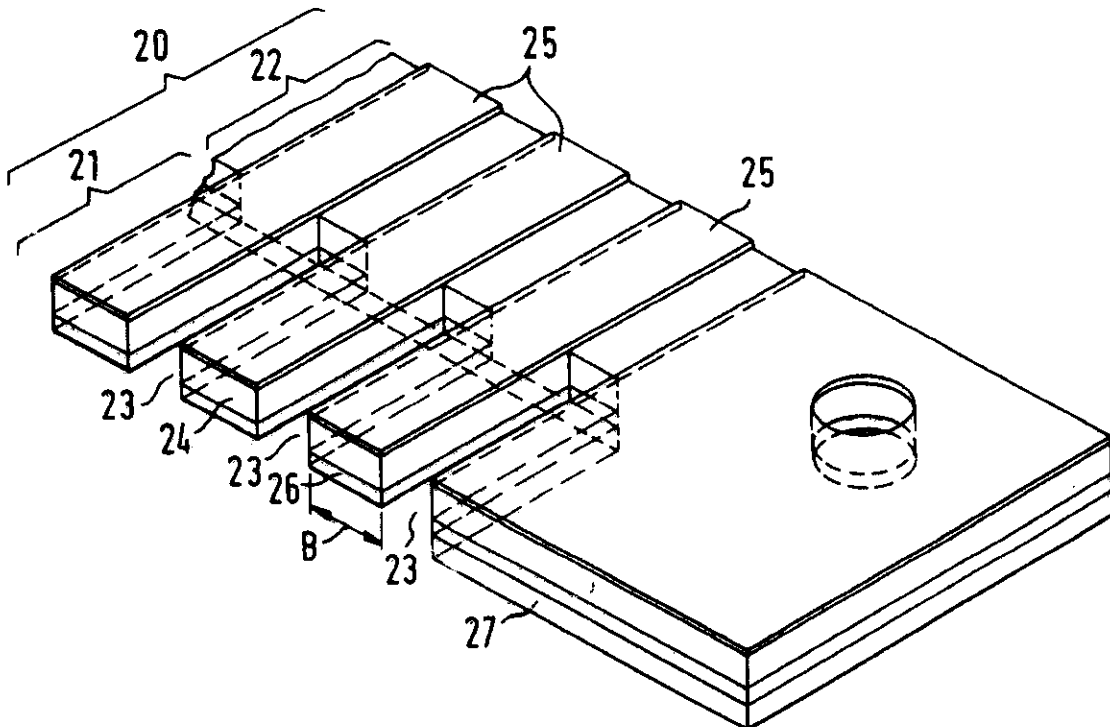

FIG. 3 (a)

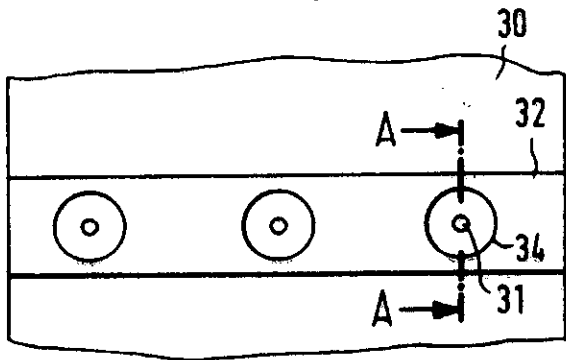

FIG. 3 (b)

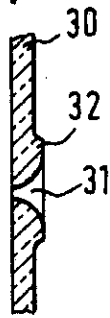

FIG. 4

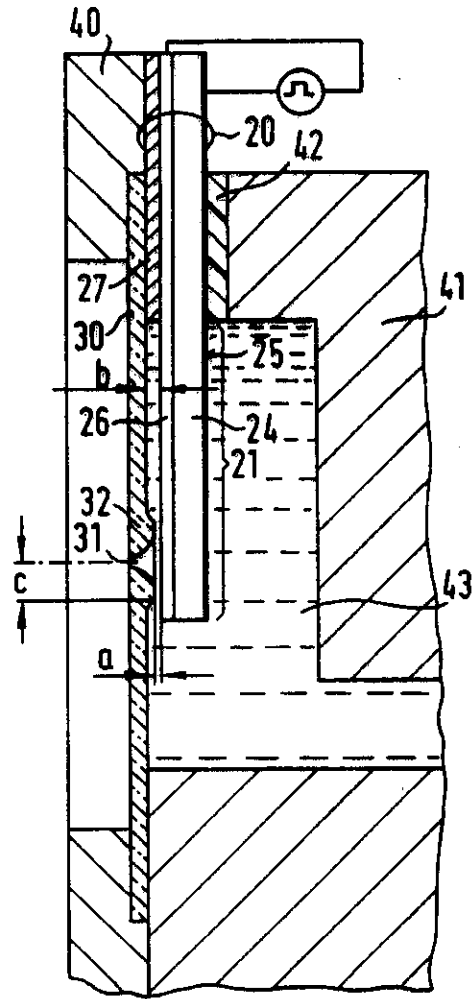

FIG. 5

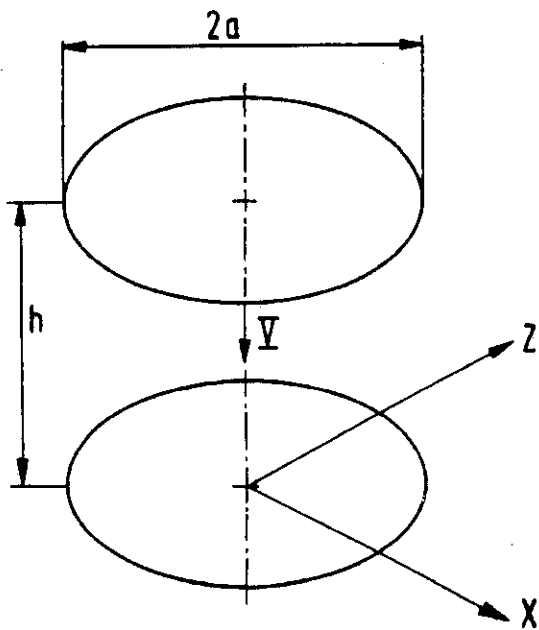

FIG. 6 (a)

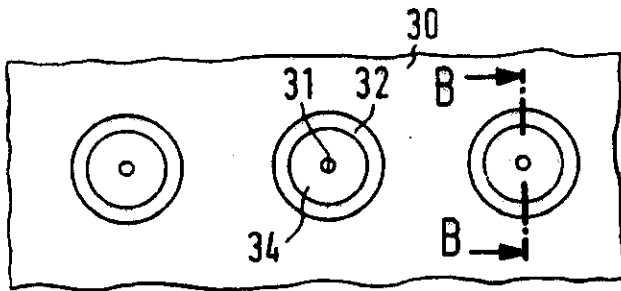

FIG. 6 (b)

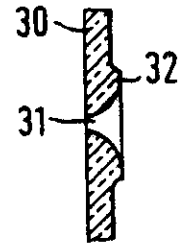

FIG. 7 (a)

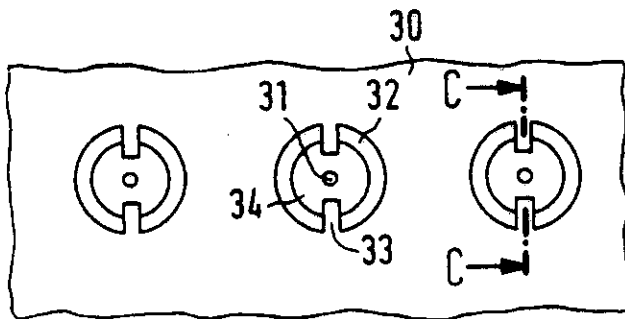

FIG. 7 (b)

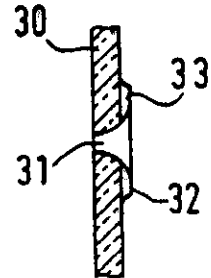

FIG. 8 (a)

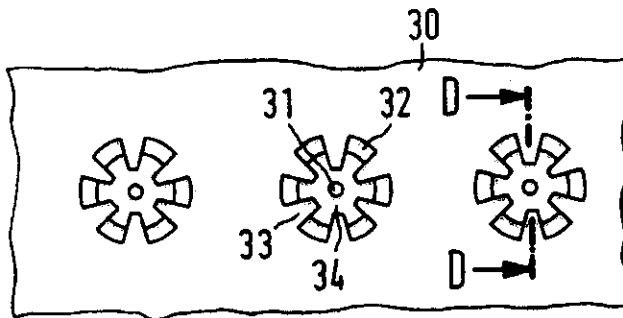

FIG. 8 (b)

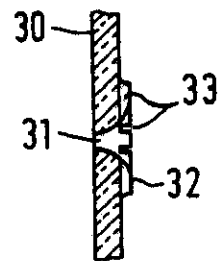

FIG. 9 (a)

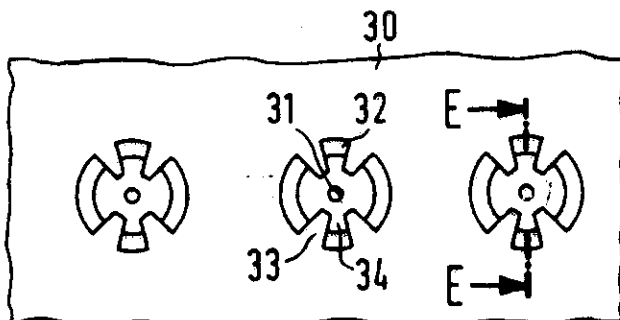

FIG. 9 (b)

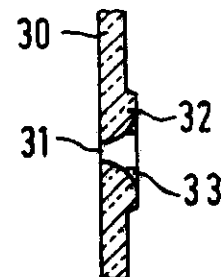

FIG .10

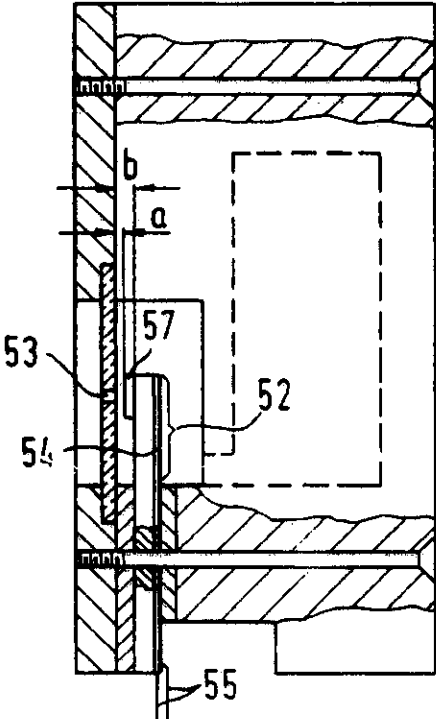

FIG .12

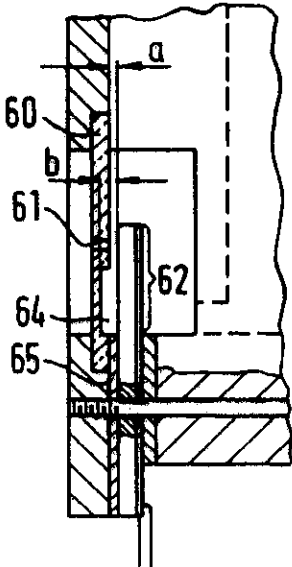

FIG .11

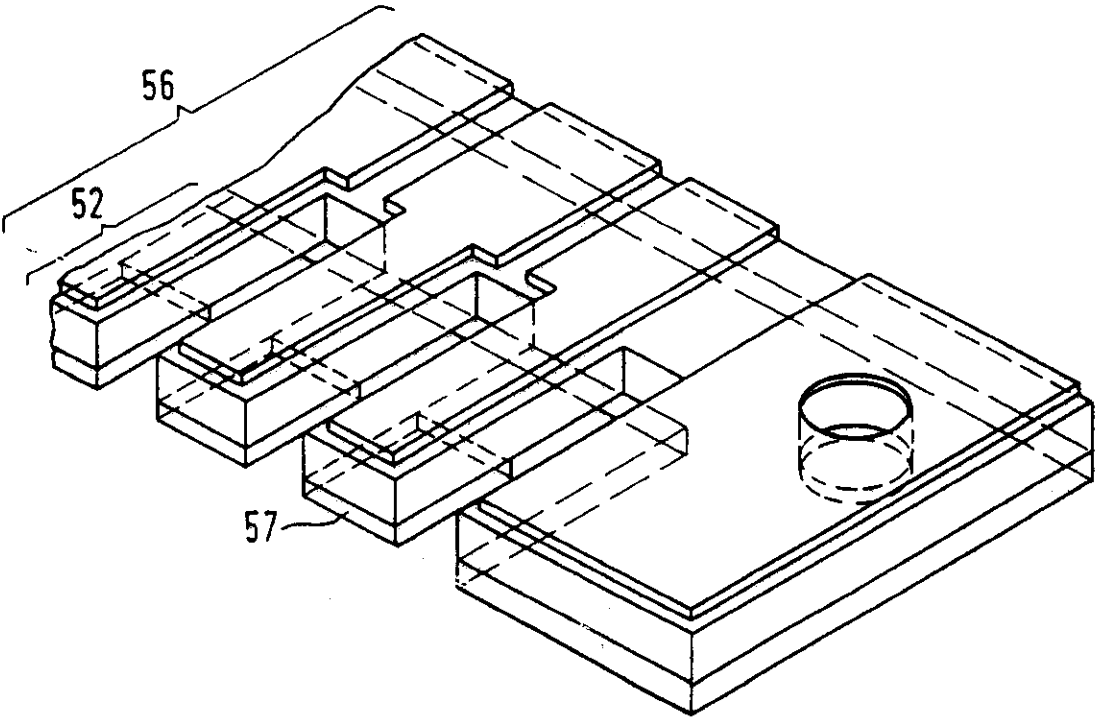

FIG. 13

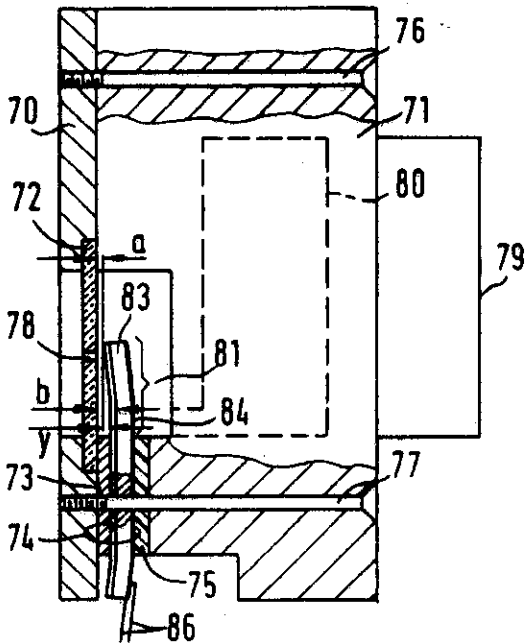

FIG. 15 (a)

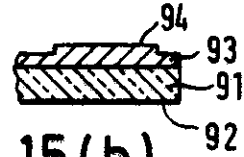
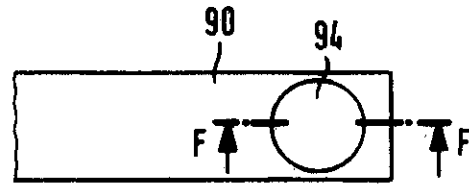

FIG. 15 (b)

FIG. 14

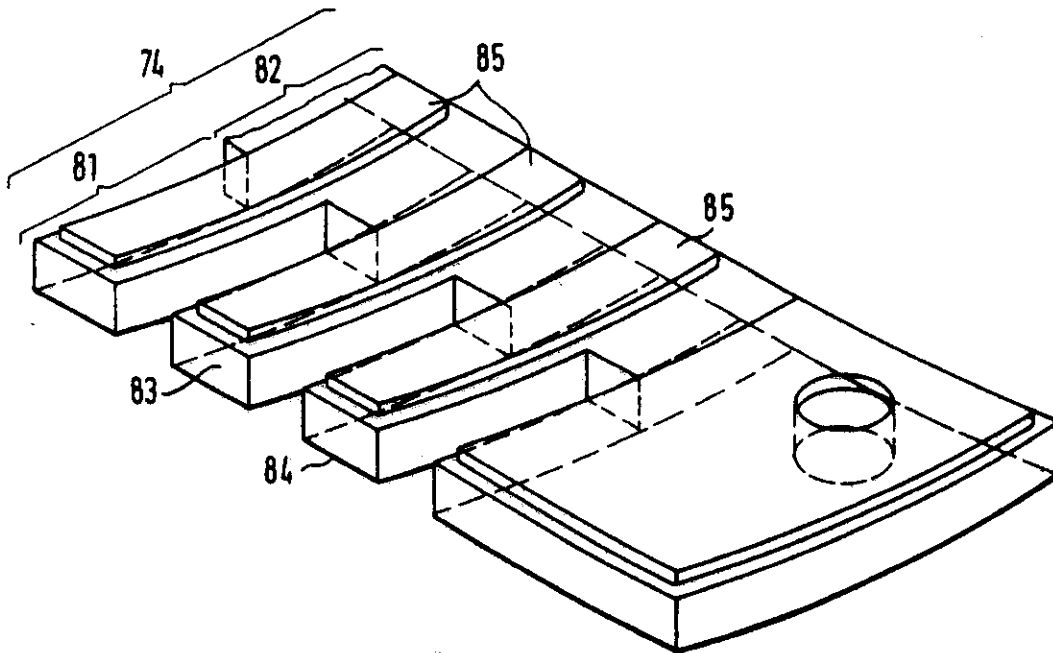

FIG. 16

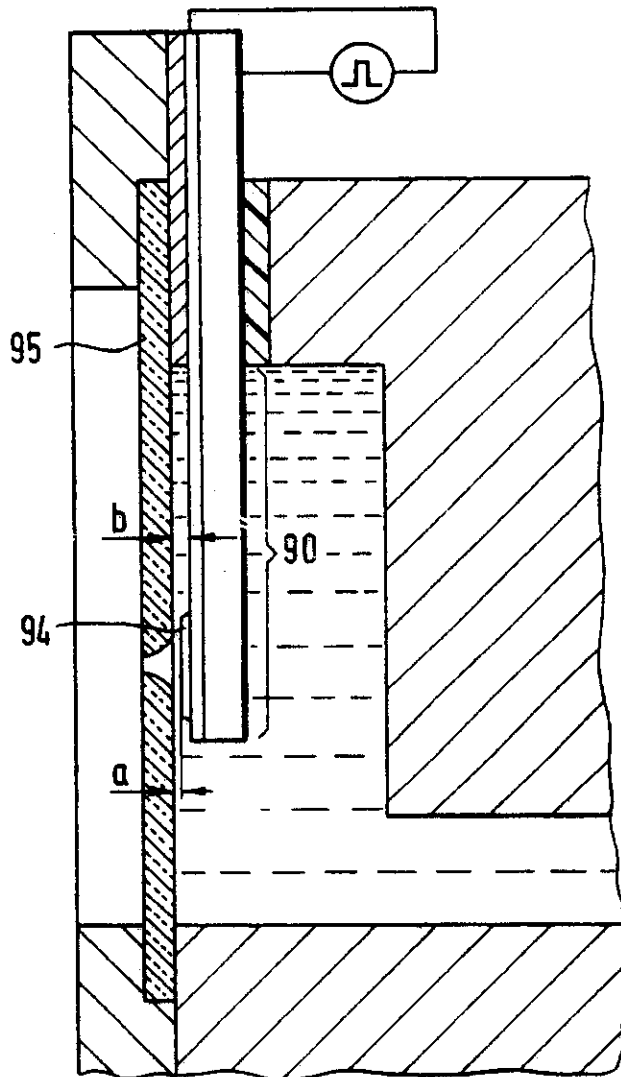

FIG.17(a)

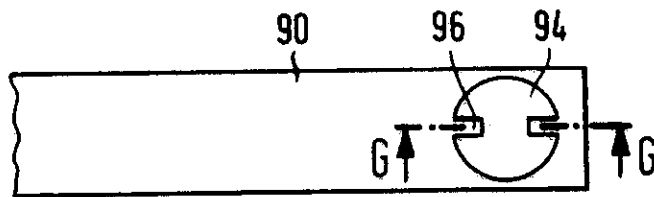

FIG.17(b)



FIG.18(a)

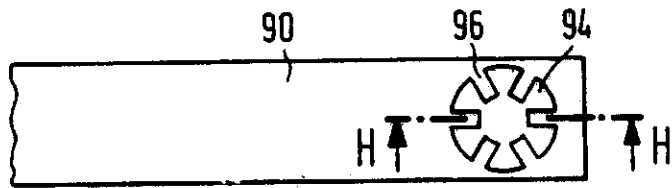

FIG.18(b)



FIG.19(a)

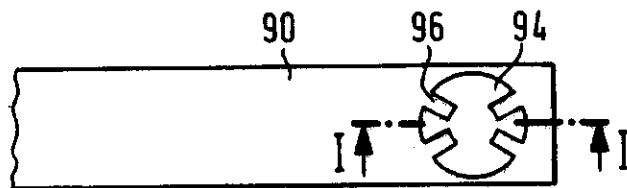

FIG.19(b)



FIG. 20(a)

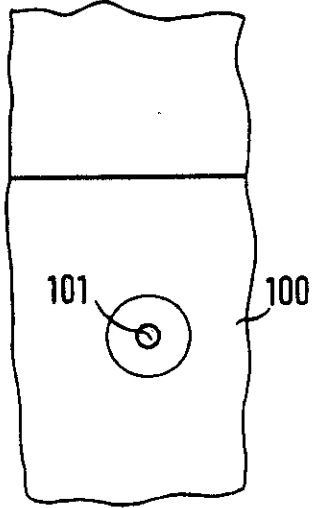

FIG. 20(b)

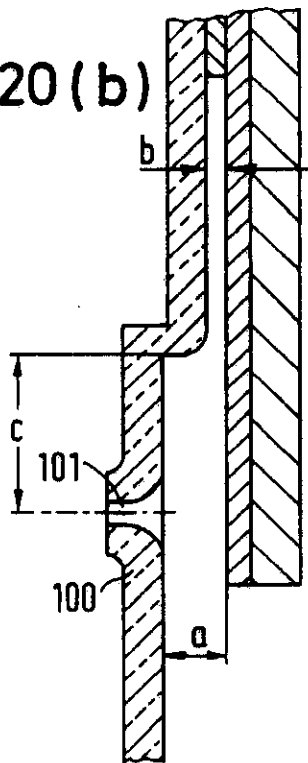

FIG. 21(b)

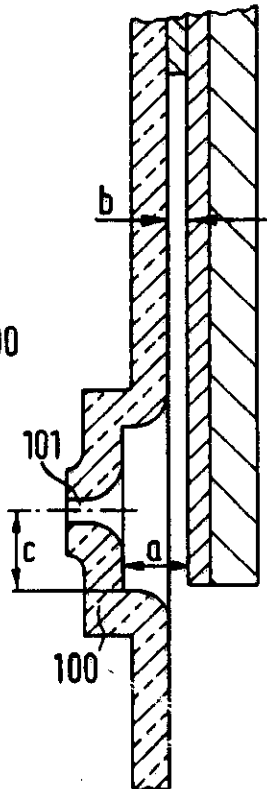

FIG. 21(a)

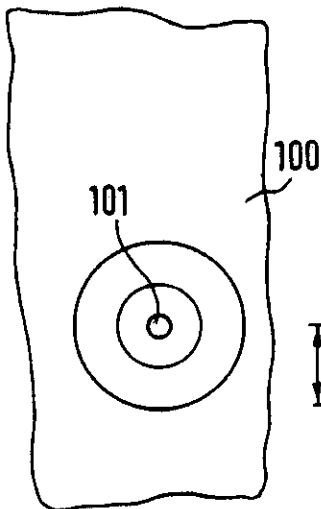
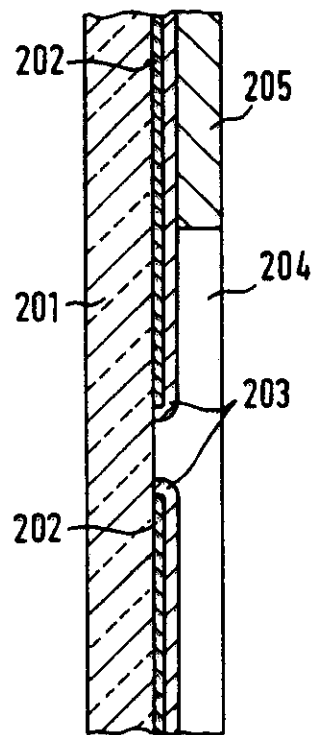

FIG. 22



REGISTER ENTRY FOR EP0337429

European Application No EP89106516.1 filing date 12.04.1989

Priorities claimed:

12.04.1988 in Japan - doc: 63089372
03.06.1988 in Japan - doc: 63137888
23.06.1988 in Japan - doc: 63155891

Designated States DE FR GB

Title INK JET HEAD.

Applicant/Proprietor

SEIKO EPSON CORPORATION, 4-1, Nishishinjuku 2-chome, Shinjuku-ku Tokyo-to,
Japan [ADP No. 50309772001]

Inventors

TSUYOSHI KITAHARA, c/o Seiko Epson Corporation, 3-5, Owa 3-chome, Suwa-shi
Nagano-ken, Japan [ADP No. 56913817001]

SHUJI YONEKUBO, c/o Seiko Epson Corporation, 3-5, Owa 3-chome, Suwa-shi
Nagano-ken, Japan [ADP No. 56913825001]

HIDEKI MOROZUMI, c/o Seiko Epson Corporation, 3-5, Owa 3-chome, Suwa-shi
Nagano-ken, Japan [ADP No. 56913833001]

KOICHI HIGASHIMURA, c/o Seiko Epson Corporation, 3-5, Owa 3-chome,
Suwa-shi Nagano-ken, Japan [ADP No. 56913841001]

MASANAO MATSUZAWA, c/o Seiko Epson Corporation, 3-5, Owa 3-chome, Suwa-shi
Nagano-ken, Japan [ADP No. 56913858001]

Classified to

B41J

Address for Service

JOSEPH MILLER, J. MILLER & CO. 34 Bedford Row, Holborn, London WC1R 4JH,
United Kingdom [ADP No. 50543347001]

EPO Representative

BLUMBACH WESER BERGEN KRAMER ZWIRNER HOFFMANN PATENTANWÄLTE,
Radeckestrasse 43, D-8000 München 60, Federal Republic of Germany
[ADP No. 50114305001]

Publication No EP0337429 dated 18.10.1989

Publication in English

Examination requested 14.08.1990

Patent Granted with effect from 07.07.1993 (Section 25(1)) with title INK JET
HEAD.

23.07.1990 EPO: Search report published on 22.08.1990

Entry Type 25.11 Staff ID.

Auth ID. EPT

17.12.1992 JOSEPH MILLER, J. MILLER & CO. 34 Bedford Row, Holborn, London WC1R
4JH, United Kingdom [ADP No. 50543347001]
registered as address for service

Entry Type 8.11 Staff ID. ER1 Auth ID. AA

17.05.1993 Notification from EPO of change of EPO Representative details from
BLUMBACH WESER BERGEN KRAMER ZWIRNER HOFFMANN PATENTANWÄLTE,
Radeckestrasse 43, D-8000 München 60, Federal Republic of Germany

[ADP No. 50114305001]

to

HOFFMANN, ECKART PATENTANWALT BLUMBACH & PARTNER, Bahnhofstrasse
103, W-8032 Gräfelfing, Federal Republic of Germany

[ADP No. 60914124001]

Entry Type 25.14 Staff ID. RD06 Auth ID. EPT

**** END OF REGISTER ENTRY ****

OA80-01
EP

OPTICS - PATENTS

09/02/95 16:01:14
PAGE: 1

RENEWAL DETAILS

PUBLICATION NUMBER EP0337429

PROPRIETOR(S)

SEIKO EPSON CORPORATION, 4-1, Nishishinjuku 2-chome, Shinjuku-ku
Tokyo-to, Japan

DATE FILED 12.04.1989

DATE GRANTED 07.07.1993

DATE NEXT RENEWAL DUE 12.04.1995

DATE NOT IN FORCE

DATE OF LAST RENEWAL 06.04.1994

YEAR OF LAST RENEWAL 06

STATUS PATENT IN FORCE