



**EUROPEAN PATENT APPLICATION**

Application number : **91309923.0**

Int. Cl.<sup>5</sup> : **H01F 27/34, H01F 27/38**

Date of filing : **28.10.91**

Priority : **29.10.90 US 604549**

Date of publication of application :  
**06.05.92 Bulletin 92/19**

Designated Contracting States :  
**DE FR GB IT**

Applicant : **GENERAL ELECTRIC COMPANY**  
**1 River Road**  
**Schenectady, NY 12345 (US)**

Inventor : **Alley, Robert Philbrick**  
**27 Hemlock Lane**  
**Clifton Park, New York 12065 (US)**  
Inventor : **Steigerwald, Robert Louis**  
**3 Sandstone Drive**  
**Burnt Hills, New York 12027 (US)**  
Inventor : **El-Hamamsy, Sayed-Amr Ahmes**  
**2120 Van Rensselaer Drive**  
**Schenectady, New York 12308 (US)**

Representative : **Pratt, Richard Wilson et al**  
**London Patent Operation G.E. TECHNICAL**  
**SERVICES CO. INC. Burdett House 15/16**  
**Buckingham Street**  
**London WC2N 6DU (GB)**

**High-frequency, high-leakage-reactance transformer.**

A high-frequency, high-leakage-reactance transformer has a section of low-permeability magnetic material disposed between planar primary and secondary windings. The low-permeability section provides a controlled flux path for the leakage flux between the primary and secondary windings. Excessive eddy currents are thus prevented from flowing in the planar windings, and high-efficiency operation is achieved. The high-leakage-reactance transformer can function both as a transformer and an inductor, thereby reducing the size of, for example, a resonant power supply or a discharge lamp ballast.

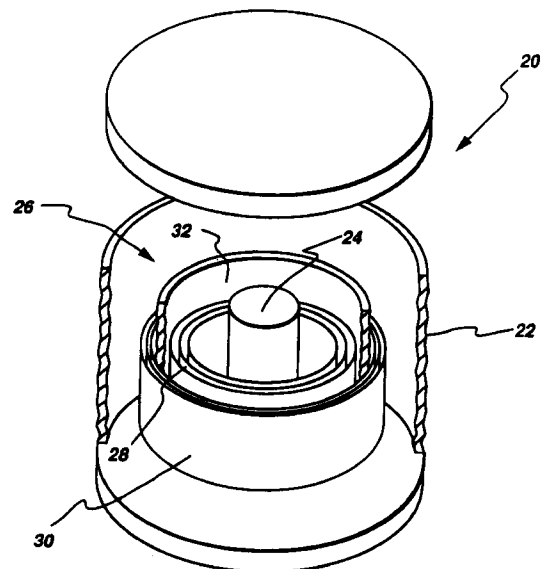

**Fig. 3**

## Field of the Invention

The present invention relates generally to magnetic circuit components. More particularly, the present invention relates to a high-frequency transformer having a high, controllable leakage reactance.

## Background of the Invention

It is well-known that the size of magnetic components can be decreased by increasing the operating frequency thereof. However, as frequency is increased, winding losses increase due to the presence of eddy currents in the conductors. These eddy currents are caused by ac effects which are magnified at high frequencies, such as skin and proximity effects and fringing fields from air gaps.

Conventional windings at low frequencies are generally solenoidal or helical and are made from circular, square, or foil conductors. At high frequencies, however, the ac-to-dc resistance ratio of such conductors increases markedly due to skin and proximity effects. Thus, for effective utilization of a conductor cross-section, it is advantageous to constrain one dimension of the conductor to one or two skin depths. Consequently, and in contrast to the low frequency case, planar windings are often employed which assist in minimizing the overall volume of an electrical component designed to carry a specified current at high frequencies. Disadvantageously, in order to carry high current or to exhibit a low resistance characteristic, the other cross-sectional dimension of the planar winding cannot be so constrained. Therefore, although conductor volume efficiency is improved by using planar windings, eddy currents and their attendant losses still persist, and the reduction of such eddy currents is of high concern.

Conventional magnetic structures, such as inductors, have high-permeability cores with lumped air gaps. A conventional core also has a winding window for containing conductors encased by an insulating material. The air gaps in a core of sufficiently small volume are so large relative to the overall window size that the fringing field flux penetrates the conductors. Such field nonuniformity generates excessive eddy current losses. As a result, the ac resistance is significantly larger than the dc resistance.

It has been proposed that one way to reduce the ac winding losses, without increasing the size of the winding window, is to distribute the air gaps uniformly around the magnetic core, as discussed in the paper entitled "Effects of Air Gaps on Winding Loss in High-Frequency Planar Magnetics" by K.D.T. Ngo and M.H. Kuo, Power Electronics Specialists Conference Proceedings, April 11-14, 1988, pp. 1112-1119, which paper is incorporated by reference herein. This distributed gap effect can be realized by constructing the inductor with a ferrite core having a low, controllable

permeability. The low-permeability core forms a closed-loop structure surrounding the winding window which contains planar copper conductors encased by an insulating material. Although a low-permeability core structure will result in reduced ac winding losses, losses will still be caused by the uneven distribution of current in the conductors resulting from field nonuniformity. Specifically, regions of high field intensity will result from the crowding of flux lines around corners of the core structure as they follow the paths of least reluctance. This high field intensity will produce undesirable eddy current circulation in the outermost conductors of the winding.

Another approach to loss reduction, also discussed in "Effects of Air Gaps on Winding Loss in High-Frequency Planar Magnetics", cited hereinabove, is to employ a multilayer winding in a distributed gap inductor. Use of a multilayer winding not only improves the aspect ratio of the core geometry, but also results in reduced core losses. Further, an inductor having a multi-layer winding of the same current and frequency rating requires a larger winding window than its single-layer counterpart, the use thereof thus alleviating the adverse effects of field nonuniformity. Unfortunately, despite the hereinabove enumerated advantages, the stacking of conductors to form a multi-layer winding causes higher proximity effect losses. The overall result, however, is an inductor having a comparable or a slightly lower ac-to-dc resistance ratio than the single-layer distributed gap inductor.

In commonly assigned U.S. Pat. No. 4,943,793 of K.D.T. Ngo and R.D. Charles, issued July 24, 1990 and incorporated by reference herein, a dual-permeability core structure for use in high-frequency magnetic components is described which exhibits low winding losses and a low ac-to-dc resistance ratio. The dual-permeability core encloses a winding window containing planar windings and comprises high-permeability and low-permeability sections positioned to produce a highly uniform, or uniformly varying, magnetic field on the winding surfaces. A magnetic structure as described in the Ngo and Charles patent is useful for constructing high-efficiency inductors and transformers.

Some high-frequency circuit applications require the use of both an inductor and a transformer. For example, a resonant power supply typically employs a resonant circuit, including an inductor, and an isolation transformer. Another exemplary application is a discharge lamp ballast, such as for a fluorescent lamp. It would be desirable, therefore, to construct a high-frequency, high-leakage-reactance transformer employing planar windings which could function as both the inductor and isolation transformer, thereby decreasing the size and increasing the efficiency of the circuit.

### Objects of the Invention

Accordingly, an object of the present invention is to provide a high-frequency, high-leakage-reactance transformer employing planar windings which exhibits low winding losses.

Another object of the present invention is to provide a high-frequency transformer employing planar windings and having a controlled leakage reactance so that it can function as both a transformer and an inductor, thereby decreasing the number of components and size of the circuit in which the transformer is employed.

### Summary of the Invention

The foregoing and other objects of the present invention are achieved in a new and improved high-frequency, high-leakage-reactance transformer employing a section of low-permeability material between planar primary and secondary windings. The low-permeability section provides a controlled flux path for the leakage flux between the primary and secondary windings. As a result, excessive eddy currents are prevented from flowing in the planar windings, and the electrostatic coupling between the primary and secondary windings is substantially reduced. High-efficiency operation is thus obtained. Moreover, the high-leakage-reactance transformer functions both as a transformer, e.g. for isolation, and an inductor. Such a combination structure advantageously reduces the number of components and size of the circuit.

### Brief Description of the Drawings

The features and advantages of the present invention will become apparent from the following detailed description of the invention when read with the accompanying drawings in which:

Figure 1 is a plot of flux lines in a lumped gap magnetic structure;

Figure 2 is a plot of flux lines in a transformer having a low-permeability section situated between a primary winding and a secondary winding in accordance with the present invention;

Figure 3 is an isometric, cutaway view of one preferred embodiment of a high-frequency, high-leakage-reactance transformer in accordance with the present invention;

Figure 4 is an isometric, cutaway view of another preferred embodiment of a high-frequency, high-leakage-reactance transformer in accordance with the present invention;

Figures 5a and 5b are a front isometric, partially cutaway, cross sectional view and a side, partially cutaway, cross sectional view, respectively, of another preferred embodiment of a high-frequency,

high-leakage-reactance transformer in accordance with the present invention; and Figure 6 is a front isometric, partially cutaway, cross sectional view of still another preferred embodiment of a high-frequency, high-leakage-reactance transformer in accordance with the present invention.

### Detailed Description of the Invention

To illustrate the principles of the present invention, Figures 1 and 2 are, respectively, axial symmetric flux line plots derived by computer simulation for an E-shaped, lumped gap magnetic core 10 and a core 12 employing a low-permeability section 14 in accordance with the present invention. Each core 10 and 12 is shown as having a planar conductor 16, representing a transformer primary winding, carrying a current of 1 ampere passing through the portion of the core representing the winding window 18. In particular, the planar conductors 16 are wound around the respective axes of symmetry, i.e. center legs 17, of the respective cores. Because the effect of a secondary winding (not shown) on each core 10 and 12 would be the same for each case, the flux line plots of Figures 1 and 2 are not extended above the legs of the core. Furthermore, each core 10 and 12 has the same inductance. Specifically, for approximately 579  $\mu\text{J}$  of excitation energy, the inductance of each core 10 and 12 is about 0.1158  $\mu\text{H}$ . From the flux plots, it is clear that the stray flux in the region of the winding window of core 12 is significantly lower than that of core 10. Since eddy currents are approximately proportional to the square of the stray flux, the eddy current losses for core 12 would be significantly less than those of core 10. For the specific example of Figures 1 and 2, the eddy current losses for core 12 would be less than about 36% of those of core 10.

Figure 3 illustrates one preferred embodiment of a high-frequency, high-leakage-reactance transformer 20 in accordance with the present invention. In particular, the transformer of Figure 1 has a pot core structure, including a cylindrical housing 22 and a core post 24 that extends between the opposite ends of the housing and is concentric therewith. The cylindrical housing and the core post are each comprised of a high-permeability material. In the interior of the housing, there is a cylindrical winding window 26 that contains a primary winding 28 and a secondary winding 10 wound about the core post. In the pot core structure, the primary and secondary windings are each preferably comprised of planar or foil conductors. In accordance with the present invention, the primary and secondary windings are separated by a low-permeability section 32 comprising a cylindrical inner wall concentric to the cylindrical peripheral wall of housing 22. The low-permeability section provides a controlled flux path for the leakage flux between the

primary and secondary windings. As a result, excessive eddy currents are prevented from flowing in the planar windings. In addition, electrostatic coupling between the primary and secondary windings is substantially reduced because of the high resistance of the transformer core material in addition to the physical separation of the windings. High-efficiency operation is thus obtained. Moreover, the high-leakage-reactance transformer can function both as a transformer, e.g. for isolation, and an inductor. Such a combination structure advantageously reduces the number of components and size of the circuit.

In an alternative pot core structure, shown in the cutaway view of Figure 4, a primary winding 34 and a secondary winding 36 each comprise a plurality of circular, planar conductors arranged in a stack along the longitudinal direction of the core. Each winding includes a hole for receiving core post 24 during assembly. Suitable windings are described in commonly assigned U.S. Pat. No. 4,959,630 of A.J. Yerman and K.D.T. Ngo, issued September 25, 1990, and in commonly assigned U.S. patent application of A.J. Yerman and K.D.T. Ngo, serial no. 359,063, filed May 30, 1989, which are incorporated by reference herein. In accordance with the present invention, the stack of planar conductors comprising the primary winding and the stack of planar conductors comprising the secondary winding are separated by a low-permeability section 38 disposed within the winding window parallel to the opposite ends of cylindrical housing 22.

A suitable high-permeability material comprises a high-permeability ferrite exhibiting low losses at high frequencies, such as a sintered ferrite of suitable composition, e.g. a manganese-zinc ferrite. A suitable low-permeability material may comprise, for example, a mixture of a ferrite powder and an organic binder or a sintered ferrite. However, any suitable low- and high-permeability magnetic materials may be used. Exemplary high- and low-permeability magnetic materials are described in U.S. Pat. No. 4,943,793, cited hereinabove. Another suitable low-permeability magnetic material is sold under the trademark KB6 by Krystinel Corporation. Methods for manufacturing dual-permeability magnetic structures are described in U.S. Pat. No. 4,943,793, cited hereinabove, and in the commonly assigned divisional patent application thereof, serial no.519,997.

Figures 5a and 5b illustrate another preferred embodiment of a high-frequency, high-leakage-reactance transformer 40 in accordance with the present invention. In particular, the transformer of Figure 5 has a rectangular housing 42 of high-permeability magnetic material. An interior high-permeability section 44 divides a winding window into two portions. A low-permeability section 48a and 48b, respectively, is located within each respective portion of the winding

window, the low-permeability sections 48a and 48b being substantially parallel to the interior high-permeability section 44. A planar primary winding 50 having terminals 51 and 52 is wound about the interior high-permeability section 44. A planar secondary winding 54 having terminals 55 and 56 is then wound about the primary winding 50 with the low-permeability sections 48a and 48b separating the primary and secondary windings. Alternatively, if desired, the positions of the primary and secondary windings may be reversed in the core.

Figure 6 illustrates still another preferred embodiment of a high-frequency, high-leakage-reactance transformer 60 in accordance with the present invention. Transformer 60 has a substantially rectangular housing 62 comprised of a high-permeability magnetic material. A high-permeability section 64 is disposed within a winding window 66 so that it is substantially parallel to the top and bottom of housing 62. A low-permeability section 68 perpendicular to the high-permeability section 64 is also disposed within winding window 66. A primary winding 70 having terminals 71 and 72 and a secondary winding 74 having terminals 75 and 76 are respectively wound about high-permeability section 64 with the low-permeability section 68 disposed therebetween.

The advantages of the transformer of the present invention are obtainable at any operating frequency, i.e. at least in the broad range from 50 Hz to 30 MHz.

While the preferred embodiments of the present invention have been shown and described herein, it will be obvious that such embodiments are provided by way of example only. Numerous variations, changes and substitutions will occur to those of skill in the art without departing from the invention herein. Accordingly, it is intended that the invention be limited only by the spirit and scope of the appended claims.

## Claims

1. A high-leakage-reactance transformer, comprising:
  - a high-permeability housing including therein a winding window;
  - a primary winding contained in said winding window;
  - a secondary winding contained in said winding window; and
  - at least one low-permeability section attached to said housing and disposed in said winding window between said primary and secondary windings so as to provide a path for leakage flux between said primary and secondary windings.
2. The transformer of claim 1 wherein:
  - said housing is of substantially cylindrical

configuration, said housing having a cylindrical peripheral wall and two opposite ends thereof, said housing further including a high-permeability core post concentric with the cylindrical peripheral wall of said housing and extending between the opposite ends thereof; and

said low-permeability section comprises an interior cylindrical wall concentric with said cylindrical peripheral wall.

3. The transformer of claim 2 wherein:

said primary winding comprises a planar winding wound about said core post; and

said secondary winding comprises a planar winding wound about said interior cylindrical wall.

4. The transformer of claim 1 wherein:

said housing is of substantially cylindrical configuration, said housing having a cylindrical peripheral wall and two opposite ends thereof, said housing further including a high-permeability core post concentric with the cylindrical peripheral wall of said housing and extending between the opposite ends thereof;

said low-permeability section divides said winding window into two separate portions, said low-permeability section being substantially parallel to said opposite ends of said housing; and

said primary and secondary windings each comprise a stack of planar conductors including a hole for receiving said core post, said primary and secondary windings each being disposed in one of said separate portions of said housing.

5. The transformer of claim 1 wherein:

said housing comprises a substantially rectangular structure having a top, a bottom, and two opposite sides, said housing further including a high-permeability section substantially parallel to said top and bottom of said housing;

said transformer comprises two low-permeability sections disposed on opposite sides of said high-permeability section and substantially parallel thereto; and

said primary winding comprises a planar winding wound about said high-permeability section, and said secondary winding comprises a planar winding wound about said primary winding with said low-permeability sections separating said windings from each other.

6. The transformer of claim 1 wherein:

said housing comprises a substantially rectangular structure having a top, a bottom, and two opposite sides, said housing further including a high-permeability section substantially parallel to said top and bottom of said housing;

said low-permeability section is substantially perpendicular to said high-permeability section; and

said primary and secondary windings each comprise a planar winding wound about said high-permeability section and each being disposed on an opposite side of said low-permeability section.

7. The transformer of claim 1 wherein said high-permeability housing and said low-permeability section are each comprised of a sintered ferrite.

8. The transformer of claim 1 wherein said high-permeability housing is comprised of a sintered ferrite and said low-permeability section is comprised of a mixture of a ferrite powder and an organic binder.

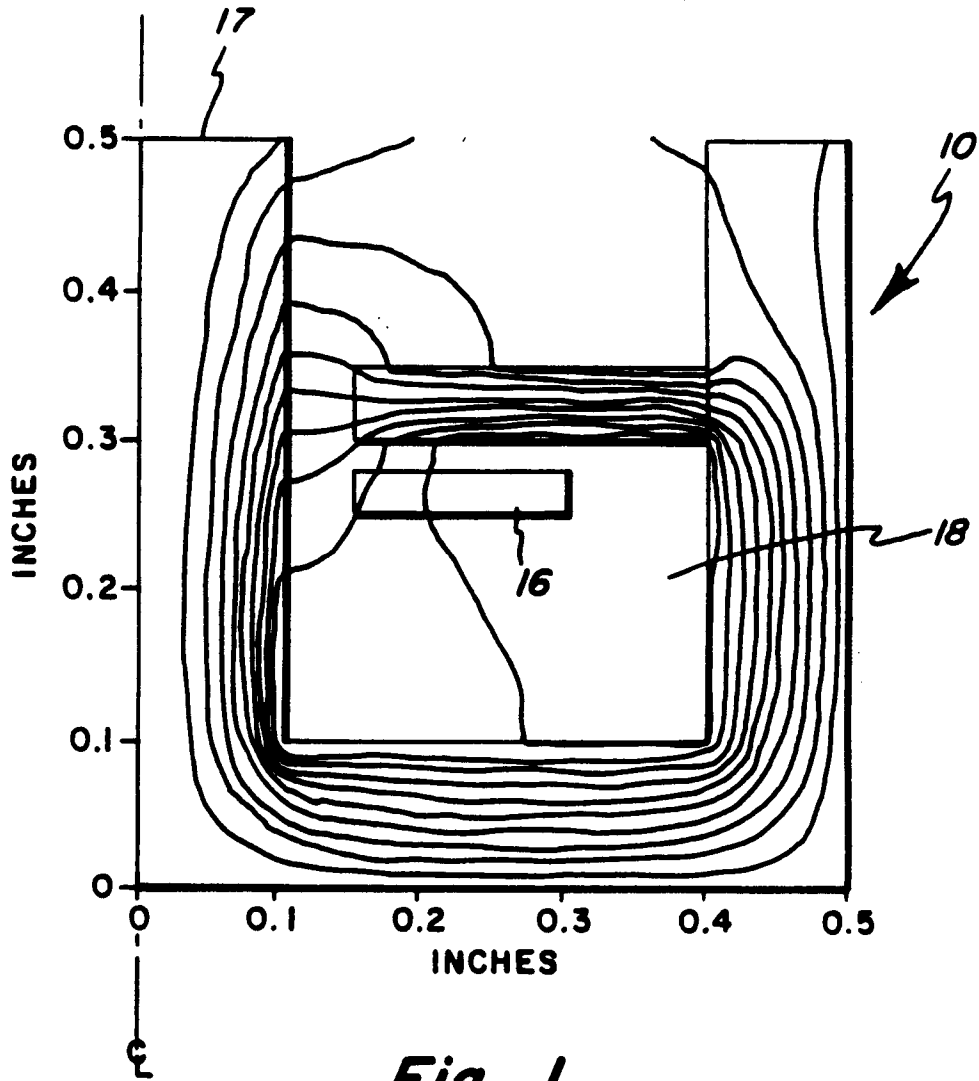

*Fig. 1*

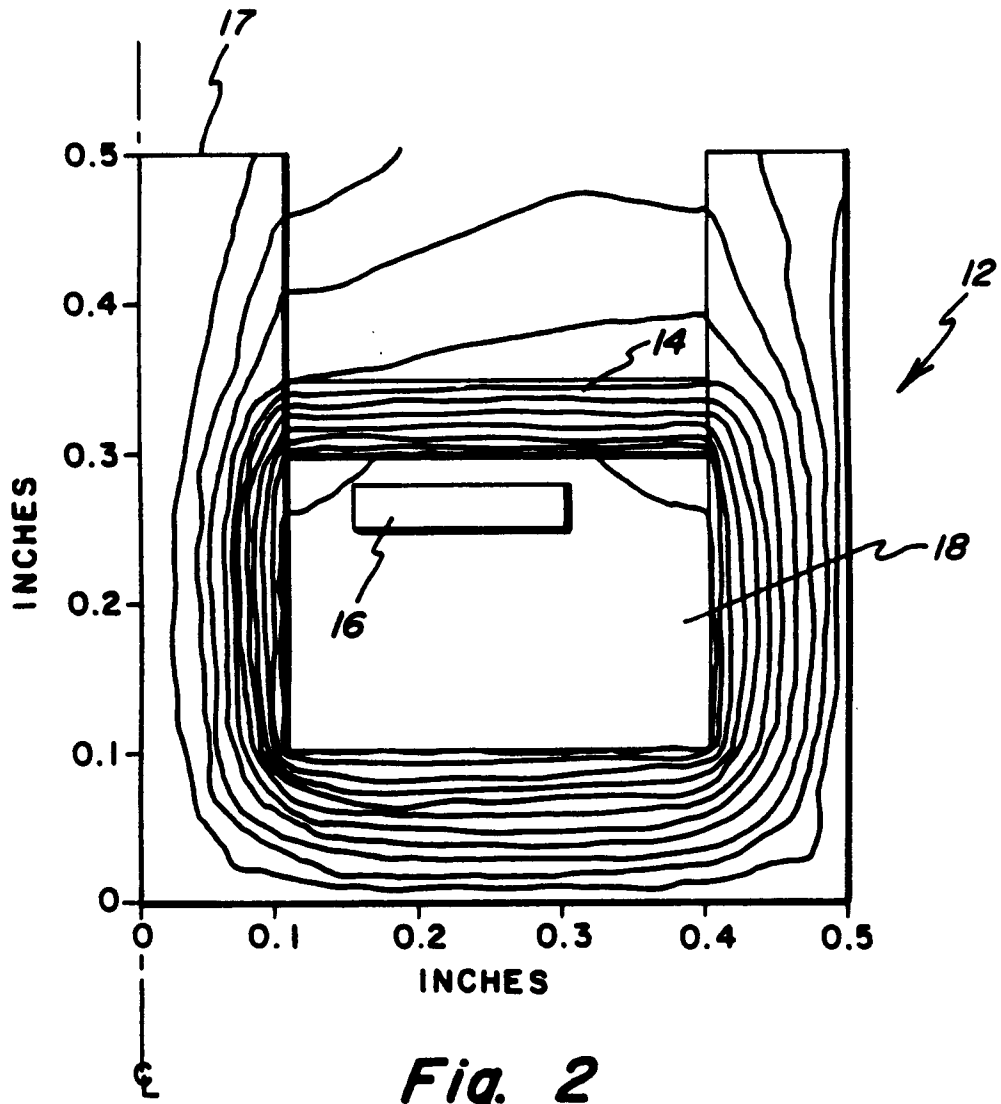

*Fig. 2*

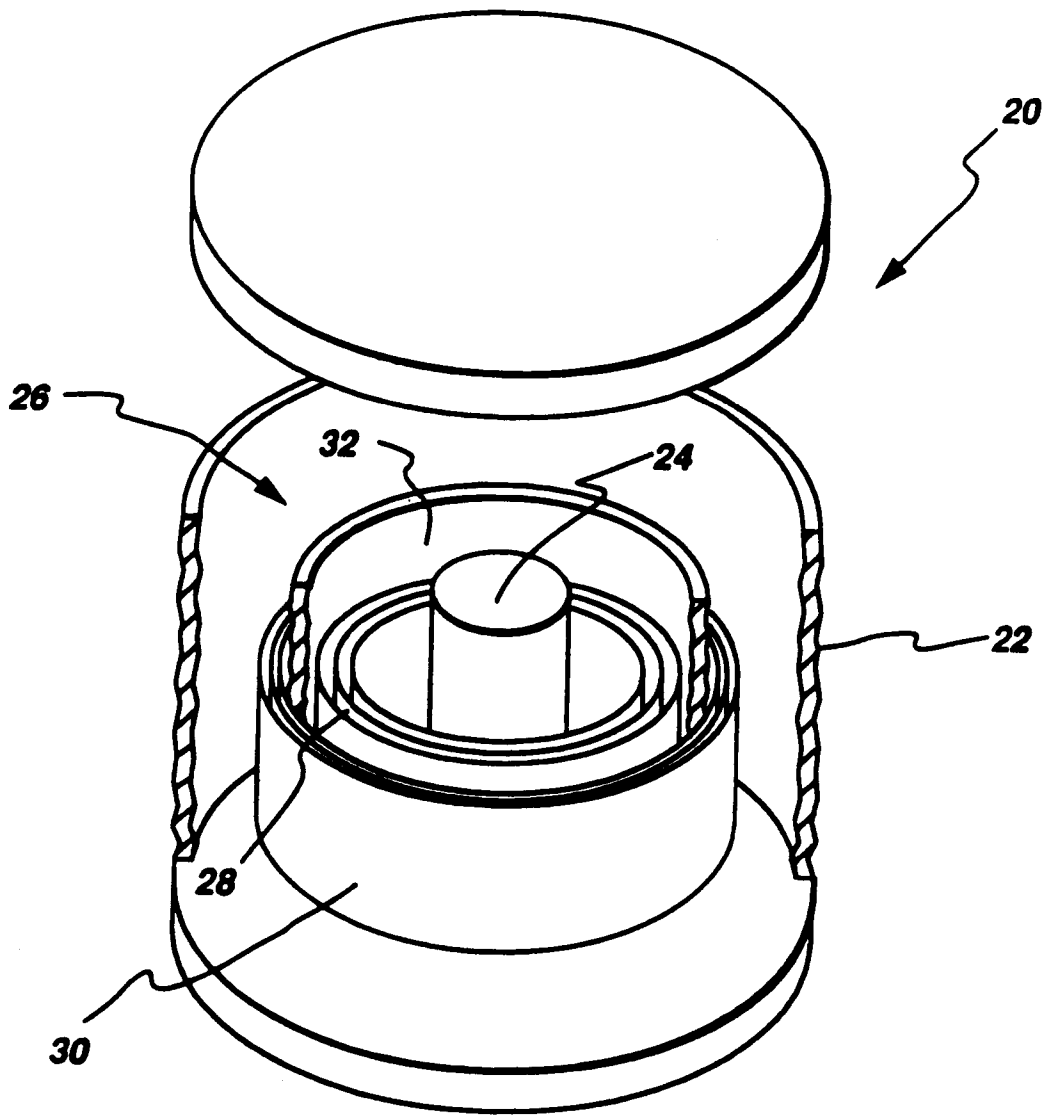

**Fig. 3**

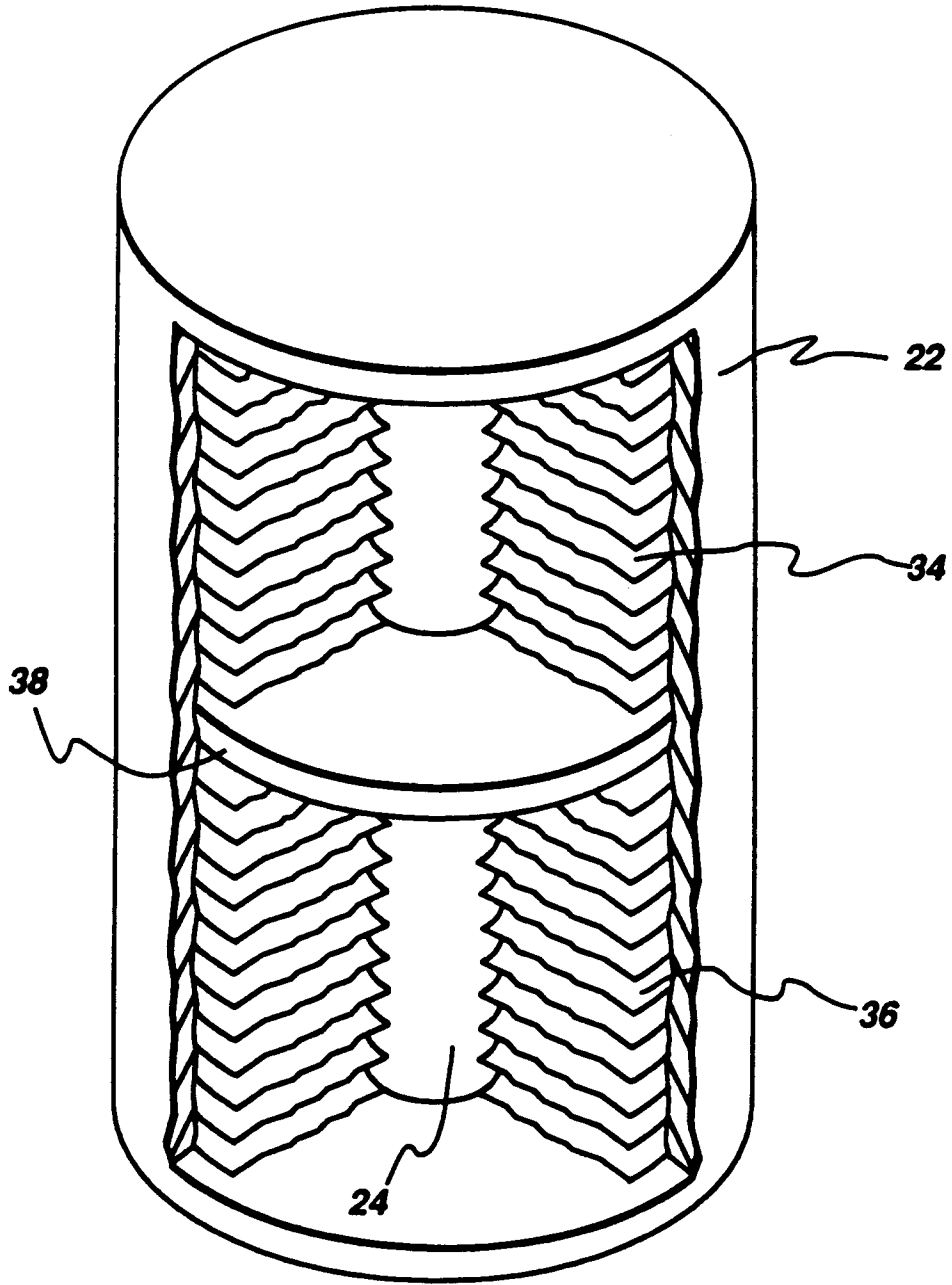

**Fig. 4**

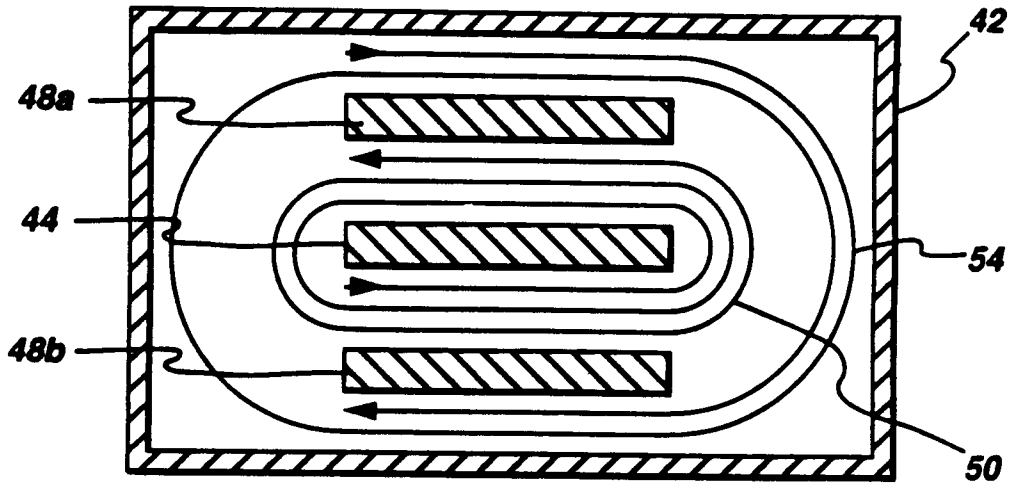

**Fig. 5b**

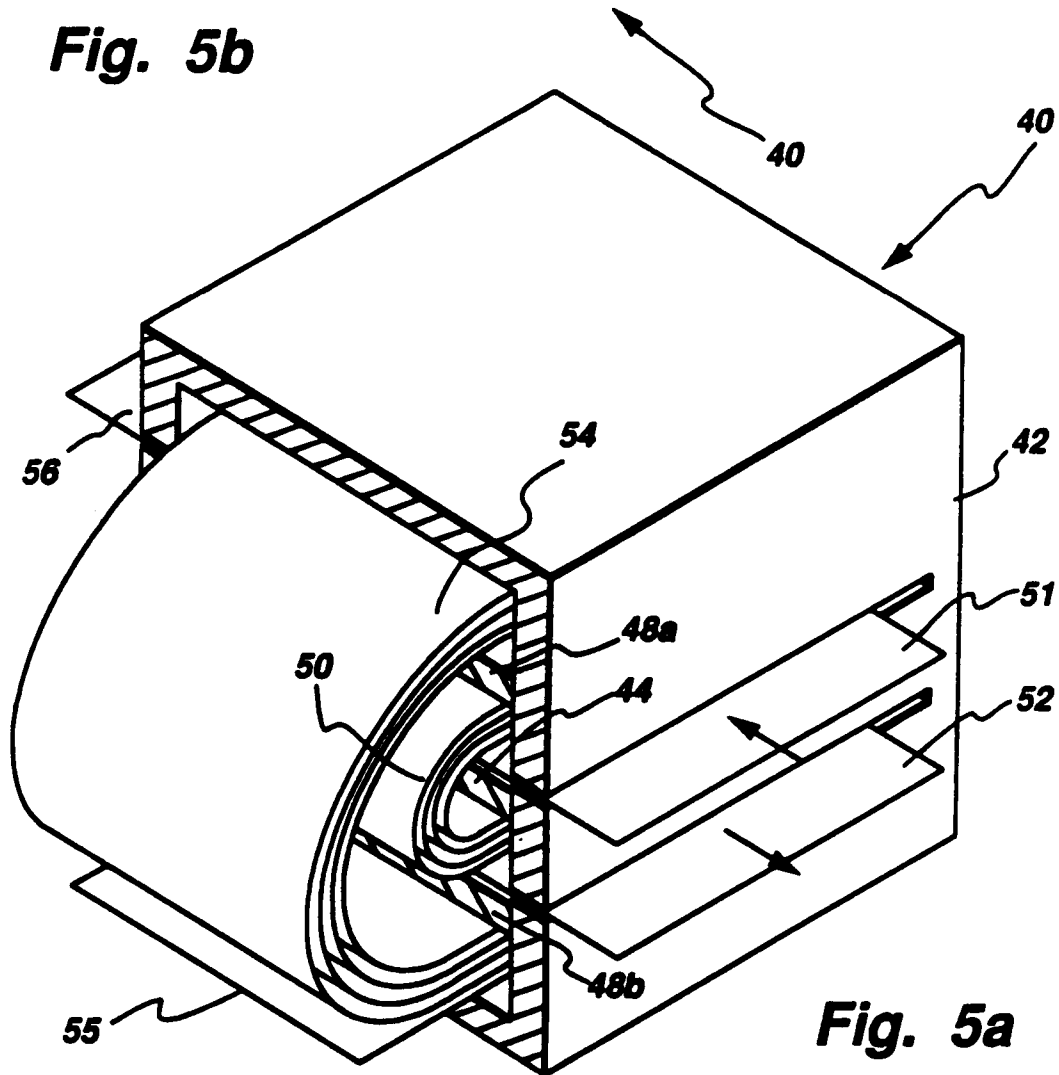

**Fig. 5a**

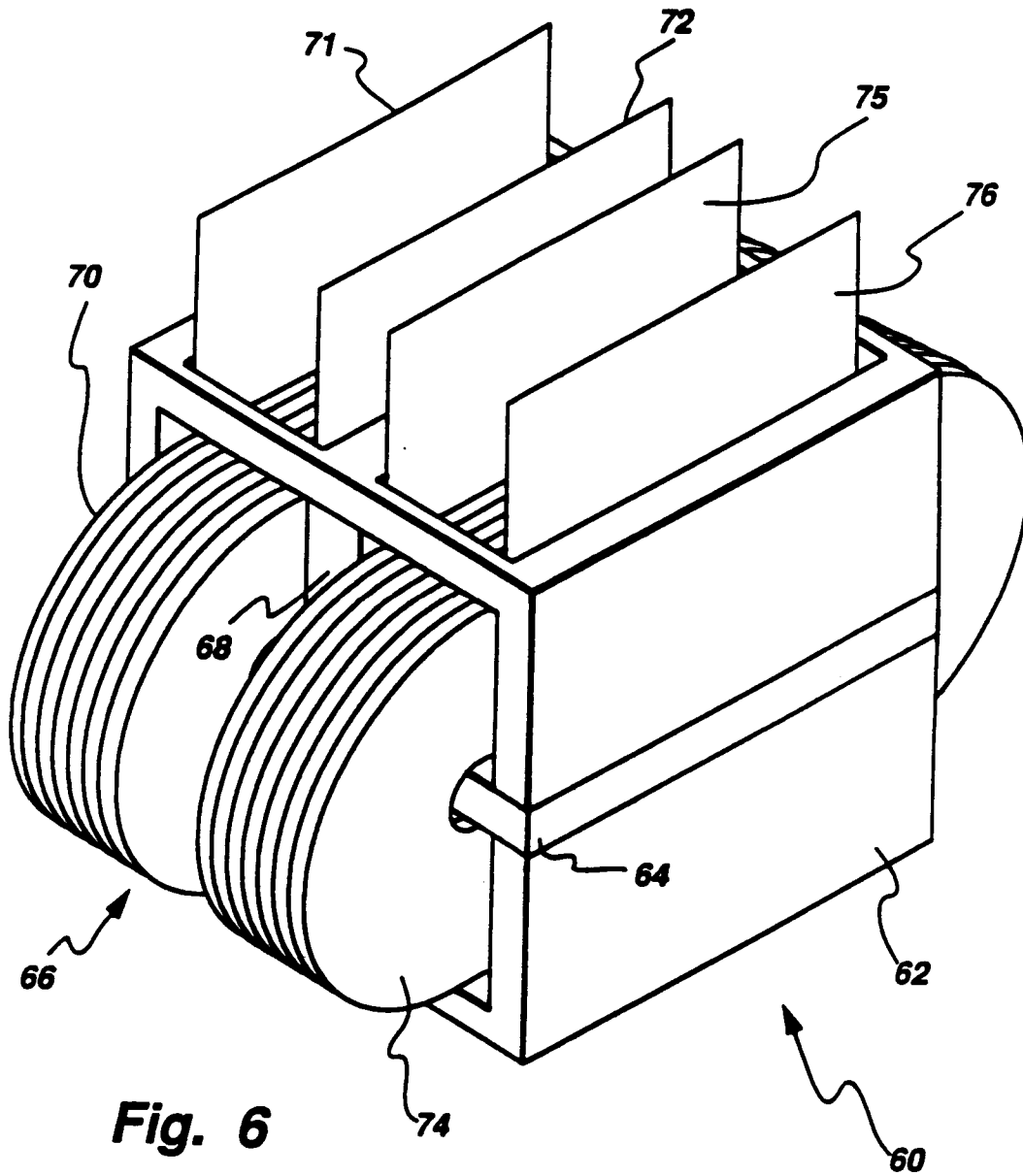

**Fig. 6**