

(No Model.)

T. MORRISON.
EDGING GUIDE FOR ROLLING MILLS.

No. 520,935.

Patented June 5, 1894.

Fig. 2.

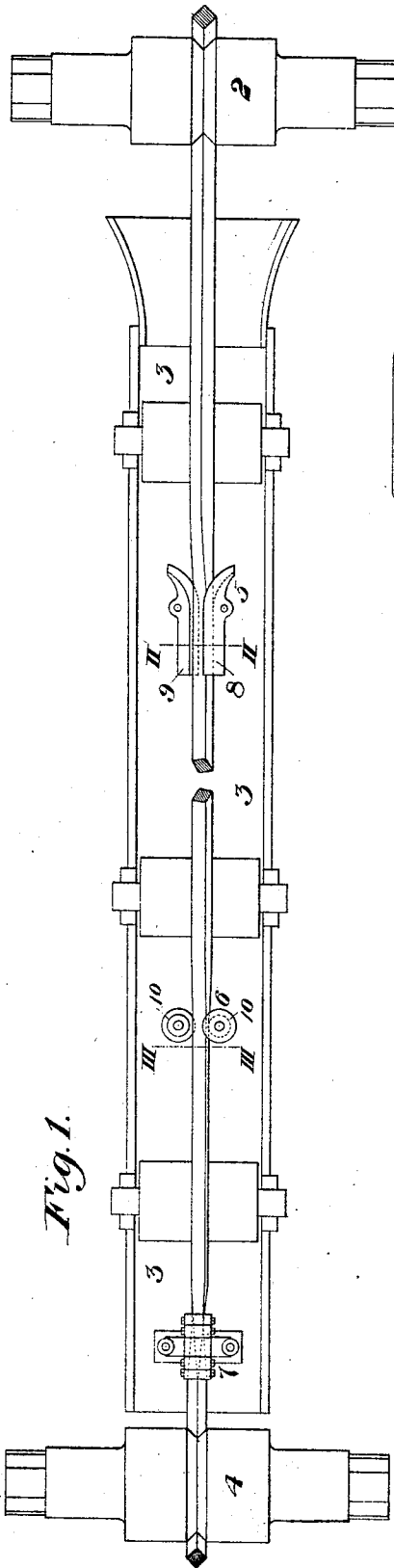
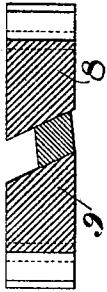

Fig. 1.

Fig. 4.

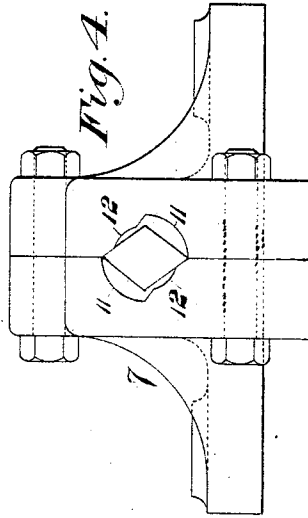
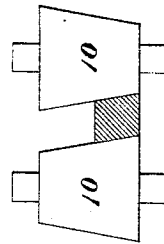

Fig. 5.



WITNESSES

W. B. Cannon
A. Morrison

INVENTOR

Thomas Morrison
by his attorneys
W. B. Cannon & Co.

UNITED STATES PATENT OFFICE.

THOMAS MORRISON, OF DUQUESNE, PENNSYLVANIA.

EDGING-GUIDE FOR ROLLING-MILLS.

SPECIFICATION forming part of Letters Patent No. 520,935, dated June 5, 1894.

Application filed July 1, 1893. Serial No. 479,408. (No model.)

To all whom it may concern:

Be it known that I, THOMAS MORRISON, of Duquesne, in the county of Allegheny and State of Pennsylvania, have invented a new and useful Improvement in Systems of Edging-Guides, of which the following is a full, clear, and exact description, reference being had to the accompanying drawings, forming part of this specification, in which—

Figure 1 is a top plan view of my improved guides located upon a feed-table. Fig. 2 is a cross section on a larger scale on the line II—II of Fig. 1. Fig. 3 is a similar view on the line III—III of Fig. 1; and Fig. 4 is a similar front elevation of the edging guide.

My invention relates to the partial rotation of bars while passing between flattening and edging passes, and it consists in a guide having an aperture provided with converging sides which twist or turn the bar as it passes therethrough, in combination with another guide through which the metal first passes and which gives an initial partial turn thereto.

It also consists in the construction and arrangement of the parts as hereinafter more fully described and set forth in the claims.

In the drawings, 2 represents a set of rolls having a flattening pass therein, and 3 a feed-table extending between these rolls and a second set 4 having an edging pass therein. The passes of the two sets of rolls are in line with each other, and to rotate the bar for insertion into the edging pass I provide the three guides 5, 6 and 7. The guide 5 consists of two separated blocks 8 and 9 rigidly secured to the feed-table, and having substantially parallel inclined faces, as shown in Fig. 2. To direct the metal thereinto and give it a gradual twist, the ends of the blocks are curved outwardly, as shown in Fig. 1, thus insuring the entry of the bar into the guide. The second guide 6 consists of a pair of vertical rolls 10, having faces inclined in the same direction as the blocks, but at a slightly less angle to the vertical, thus giving a further turn to the bar. The third or edging guide is shown in Fig. 4, and its opening has two opposite arc-shaped edges 11, and two

similar arcs 12, having a shorter radius and joined by straight lines to the ends of the first named arcs. From the face of the guide these surfaces converge to the vertical diamond-shape in which the metal enters the rolls, having been turned a quarter revolution by the several guides.

The advantages of my improved system are apparent, since the whole twisting or edging action is done automatically. In practice I have found that a preliminary guide is necessary with the guide having converging faces, as otherwise the metal will stop in this guide, there not being sufficient friction upon the feed-rollers to drive it through the same. The device is easily applied to existing tables, and is positive in its action and not liable to get out of order.

Modifications may be made in the form and arrangement of the several guides without departure from my invention, since what I claim is—

1. The combination with a final guide having converging faces, of a preliminary guide separated therefrom and arranged to give an initial twist to the metal; substantially as described.

2. The combination with the final guide having converging faces, of a preliminary guide consisting of two blocks having inclined substantially parallel faces; substantially as described.

3. The combination with the final guide having converging faces, of a preliminary guide consisting of two rollers having inclined surfaces; substantially as described.

4. The combination with the final guide having converging faces, of preliminary guides one consisting of two blocks having inclined faces, and the other of two rollers having inclined surfaces; substantially as described.

In testimony whereof I have hereunto set my hand.

THOMAS MORRISON.

Witnesses:

H. M. CORWIN,
GEO. B. MOTHERAL.