



INTERNATIONAL APPLICATION PUBLISHED UNDER THE PATENT COOPERATION TREATY (PCT)

(51) International Patent Classification ⁶ : B65D 81/22, A61L 2/18, G02C 13/00	A1	(11) International Publication Number: WO 96/22927 (43) International Publication Date: 1 August 1996 (01.08.96)
(21) International Application Number: PCT/DK96/00036 (22) International Filing Date: 23 January 1996 (23.01.96) (30) Priority Data: 0075/95 23 January 1995 (23.01.95) DK (71)(72) Applicant and Inventor: ANDERSEN, Thorkild [DK/DK]; Siriusvej 13, DK-8370 Hadsten (DK). (74) Agent: HOFMAN-BANG & BOUTARD, LEHMANN & REE A/S; Adelgade 15, DK-1304 Copenhagen K (DK).	(81) Designated States: AL, AM, AT, AU, AZ, BB, BG, BR, BY, CA, CH, CN, CZ, DE, DK, EE, ES, FI, GB, GE, HU, IS, JP, KE, KG, KP, KR, KZ, LK, LR, LS, LT, LU, LV, MD, MG, MK, MN, MW, MX, NO, NZ, PL, PT, RO, RU, SD, SE, SG, SI, SK, TJ, TM, TR, TT, UA, UG, US, UZ, VN, ARIPO patent (KE, LS, MW, SD, SZ, UG), Eurasian patent (AZ, BY, KG, KZ, RU, TJ, TM), European patent (AT, BE, CH, DE, DK, ES, FR, GB, GR, IE, IT, LU, MC, NL, PT, SE), OAPI patent (BF, BJ, CF, CG, CI, CM, GA, GN, ML, MR, NE, SN, TD, TG). Published <i>With international search report.</i> <i>Before the expiration of the time limit for amending the claims and to be republished in the event of the receipt of amendments.</i> <i>In English translation (filed in Danish).</i>	

(54) Title: A DISINFECTION SYSTEM FOR DISINFECTION OF CONTACT LENSES

(57) Abstract

Users of contact lenses daily disinfect the contact lenses to avoid trouble in use. Several disinfection systems are known for the purpose, but all-in-one systems, where the disinfection liquid is used for disinfection as well as for insertion of the lenses, have gradually become the preferred disinfection system. The disinfection agent in these liquids is relatively weak, as, otherwise, it would disturb the environment of the eye. The problem of the all-in-one systems, however, is that the already weak disinfecting effect of these liquids is reduced when left to stand in the containers, in which they are supplied, because of bacterial attacks.

This specification provides a method ensuring that the disinfection liquid (24) maintains its strength until the moment when it is used, as well as a specially adapted lens case (2) to receive a disposable container (20), whose opening is provided with a tear-of seal (22) which is removed immediately before use, said container containing a suitable amount of disinfection liquid (24). The use of the disposable container system also obviates bacterial growth in the container (4) of the lens case.

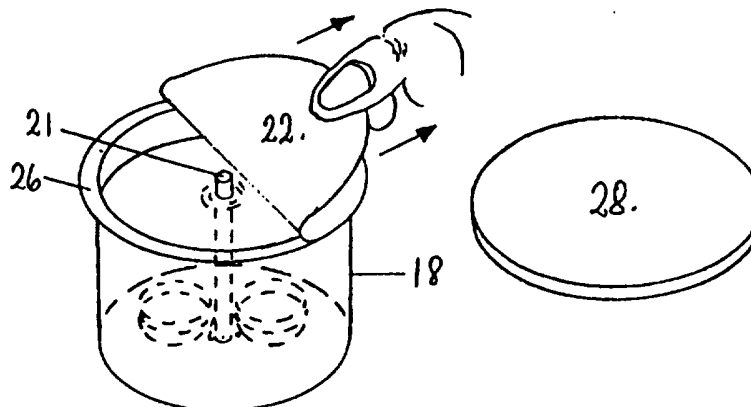

FOR THE PURPOSES OF INFORMATION ONLY

Codes used to identify States party to the PCT on the front pages of pamphlets publishing international applications under the PCT.

AM	Armenia	GB	United Kingdom	MW	Malawi
AT	Austria	GE	Georgia	MX	Mexico
AU	Australia	GN	Guinea	NE	Niger
BB	Barbados	GR	Greece	NL	Netherlands
BE	Belgium	HU	Hungary	NO	Norway
BF	Burkina Faso	IE	Ireland	NZ	New Zealand
BG	Bulgaria	IT	Italy	PL	Poland
BJ	Benin	JP	Japan	PT	Portugal
BR	Brazil	KE	Kenya	RO	Romania
BY	Belarus	KG	Kyrgystan	RU	Russian Federation
CA	Canada	KP	Democratic People's Republic of Korea	SD	Sudan
CF	Central African Republic	KR	Republic of Korea	SE	Sweden
CG	Congo	KZ	Kazakhstan	SG	Singapore
CH	Switzerland	LI	Liechtenstein	SI	Slovenia
CI	Côte d'Ivoire	LK	Sri Lanka	SK	Slovakia
CM	Cameroon	LR	Liberia	SN	Senegal
CN	China	LT	Lithuania	SZ	Swaziland
CS	Czechoslovakia	LU	Luxembourg	TD	Chad
CZ	Czech Republic	LV	Latvia	TG	Togo
DE	Germany	MC	Monaco	TJ	Tajikistan
DK	Denmark	MD	Republic of Moldova	TT	Trinidad and Tobago
EE	Estonia	MG	Madagascar	UA	Ukraine
ES	Spain	ML	Mali	UG	Uganda
FI	Finland	MN	Mongolia	US	United States of America
FR	France	MR	Mauritania	UZ	Uzbekistan
GA	Gabon			VN	Viet Nam

A disinfection system for disinfection of contact lenses

The invention concerns a disinfection system for disinfection of contact lenses and comprising a sealed disposable package containing a suitable amount of disinfection liquid to disinfect a set of contact lenses.

Users of contact lenses are aware that, at best, contact lenses are to be cleaned and disinfected daily to avoid trouble in use.

In practice, disinfection of contact lenses takes place in that a disinfection liquid from a container is poured into a specially designed lens case in which the cleaning process takes place. The lens case consists of a lens holder with a lens basket usually secured to the underside of the lens case lid as well as a container to receive disinfection/neutralization liquid on to which the lid may be screwed. When the contact lenses have been placed in the lens baskets, the lens case lid is screwed on the case, whereby the lens baskets with the contact lenses are immersed into the disinfection liquid in the container and are thereby cleaned.

Various types of liquids are used for cleaning contact lenses, depending on the cleaning system used by the user. One of the systems comprises the use of two liquids, the method comprising first immersing the lenses into hydrogen peroxide (H_2O_2), which is a very strong disinfecting cleaning liquid. After the disinfection, the lenses are immersed into a neutralization liquid, and then the contact lenses are ready for use. Sometimes the users of this system forget how far they have come in the cleaning process, and since the neutralization liquid has the same colour as the hydrogen peroxide solution, the user may easily be mistaken or his memory may be at

fault, and consequently there have been several cases where the user has believed that the lenses had been neutralized and have then inserted them in the eye directly from the hydrogen peroxide solution, which is very painful.

To avoid such unfortunate actions, DK Patent No. 168 746 B1 proposes a cleaning system where the contact lenses are immersed into a two-compartment case with hydrogen peroxide, but where the case contains a third compartment which communicates with the said compartments and in which a soluble tablet containing a neutralization agent (catalase) is placed. The gradual dissolution of the tablet neutralizes the hydrogen peroxide solution so that the contact lenses will be disinfected and neutralized when the tablet has been dissolved completely after a certain period of time. However, a drawback of this disinfection system is that sometimes the user forgets to place the tablet in the case, so that the contact lenses are inserted without having been neutralized. Another risk is that the user inserts the contact lenses before the tablet has been dissolved completely and the hydrogen peroxide solution has not been neutralized completely.

Today, all-in-one liquids have been developed for simultaneous cleaning, disinfection and insertion of contact lenses, the idea being to take the lens directly from the disinfection liquid and to insert it in the eye. The disinfection agent in these liquids is relatively weak, since, otherwise, it would disturb the environment of the eye and cause allergic reactions, because the lenses are not neutralized before being inserted. The all-in-one liquids are supplied in containers/bottles containing up to 360 ml, sufficient for two months' consumption, if the lenses are disinfected daily. In practice, 360 ml are frequently enough for more than two months, as the user

saves or just uses the contact lenses at intervals. Health authorities have generally recommended smaller container sizes, corresponding to one month's consumption, it being desired to reduce the risk of bacterial growth in the container. Frequently, the container is stored at bathrooms with many bacteria and fungi, and the users frequently forget to screw the lid on to the container after use. An American study (Donzis) has shown bacterial growth in 11-66% of the containers.

10

The bacterial growth in the containers reduce the effect of disinfection agent, weak as it is, so that its disinfecting effect is reduced (has been reduced) already before it gets into contact with the contact lenses. The disinfection of the contact lenses will thus be incomplete, whereby the eye will be liable to infection.

15

The conclusion has been that the safest form of package of all-in-one liquids is a disposable bottle, commonly called a unit dose, having a ml content corresponding to precisely one disinfection. Such containers containing 15 ml are known, but are relatively expensive, and their bottle-like shape enables the user to use one half and to save the rest for the next day, which involves a risk of bacterial growth.

25

The previously mentioned lens case is used for disinfecting contact lenses with the all-in-one liquids and is thus a decisive element of the actual disinfection process. Because of the ability of bacteria to form their own protecting biofilm, it is difficult to keep the lens case clean, and today it is therefore recommended to exchange the case as frequently as every month. Exchange every three months is perhaps acceptable, if the user users a strong disinfection agent, e.g. 3% hydrogen peroxide, which, however, requires neutralization of the

30

35

disinfection agent and the lens before the lens is inserted.

5 Studies (Donzis) have shown that bacterial growth in lens cases differs significantly, depending on the disinfection agent used, within 3 weeks' use of a new case. If the hydrogen peroxide system is used, there is no bacterial growth within the first 3 weeks. If, however, all-in-one systems are used, growth occurs in 25% of the cases within the first 21 days. Thus, with bacterial growth in the case, the situation is quite different when using a so-called all-in-one system as the disinfection system.

15 The conclusion of the study is that if an all-in-one disinfection system is used, it is very important to maintain the effect of the disinfection agent during storage in the container at the user's. Further, it is very important to use a sufficient and correct amount of disinfection agent to disinfect the contact lenses. In addition, the lens case is to be exchanged, or sterilized in another manner to avoid reducing the effect of the disinfection agent in relation to the lens with the consequent risk of eye infection.

25

EP A1 381 616, EP A1 401 163 and FR A1 2 674 217 disclose disposable systems for cleaning contact lenses.

30 EP A1 381 616 concerns a disposable system for cleaning contact lenses, which comprises a first container to receive contact lenses and a second container containing sterilization or disinfection agent. The first container has a means to pierce the lid on the second container when the second container is folded over the first container. The container with contact lenses contains a catalyst to degrade the sterilization agent.

35

EP A1 401 163 concerns a disposable system comprising two pairs of containers. The first pair contains a sterilization agent, and the second pair contains a neutralization agent. Contact lenses are cleaned by first placing the lenses in their respective containers with sterilization agent and then transferring the lenses to the containers with neutralization agent. The system may be provided with a lid, if the lenses are to be stored in the system for an extended period of time. Further, the system may be provided with a spoon-like means to handle the lenses.

FR A1 2 674 217 concerns a disposable container containing a cleaning liquid. In use, the lid of the container is removed by breaking a fragile area, and then the lenses are placed in the liquid. The lid may be applied to the container again.

These disposable systems have a number of drawbacks:

- The lenses are to be handled either by the fingers or by a spoon-like means, which makes handling risky and lens damage likely.
- The disposable systems are restricted either to all-in-one liquids or to two-liquid disinfection systems.
- The disposable systems are made of a fragile material, which makes them mechanically unstable during transport (risk of leakage).
- It is likely that the lenses are discarded together with the disposable system, as the lenses are difficult to see when they are present in the liquid.

The object of the invention is to provide a method of disinfecting contact lenses in a lens case filled with a disinfection liquid, where the contact lenses are placed in a lens basket suspended from a case lid and down in the disinfection liquid when the lid is screwed on to the container, obviating the above-mentioned drawbacks, and to ensure that the lens user uses the correct amount of disinfection liquid, and to ensure that the effect of the disinfection liquid is maintained until the moment when it contacts the contact lenses.

This object is achieved by a new distribution principle which radically departs from the traditional principles, where distribution of disinfection liquids to disinfect contact lenses takes place in larger or smaller bottles from which the user pours the disinfection liquid into the container of a lens case in which the disinfection process takes place.

The new distribution principle consist of a new disinfection system to disinfect contact lenses of the stated type, characterized in that the disposable package is formed by a disposable container formed with such a wide mouth as to be suitable for receiving holding means for contact lenses, whereby the disposable container may be used as a disinfection container in connection with disinfection of the contact lenses. Thus, in addition to serving as a distribution unit in the form of a disposable package, the disposable container also serves as a disinfection container/vessel in connection with disinfection of contact lenses. With the new principle, both the disinfection liquid and the disposable container are exchanged after completed disinfection of the contact lenses, thereby eliminating the risk of bacterial growth in the container in which the disinfection takes place, and allowing the disinfection liquid to maintain its op-

timum effect until the moment when the seal on the disposable container is torn off and the lens baskets with the contact lenses are immersed into the disinfection liquid. Another advantage of the new disinfection principle is that when using disposable containers it ensures that the lens user uses the correct amount of disinfection liquid to disinfect the contact lenses.

At its opening, the disposable container is provided with an annular flange on whose upper side a tear-off sheet seal is attached, as stated in claim 2. This attachment method, providing a good contact face between the sheet and the flange, ensures that the disinfection liquid is protected effectively against bacterial attacks during storage until use. The flange moreover has several other functions, which will be mentioned below.

When the disposable container can also accommodate the means stated in claim 3 to receive the contact lenses or holding means for these, it is additionally ensured that the contact lenses may be effectively disinfected, and following disinfection of the contact lenses, it is moreover possible - in addition to exchange of disinfection liquid and the container in which the disinfection process takes place - to exchange the lens baskets more frequently than in the use of the traditional lens cases. The frequent exchange of the lens baskets means that they will not be infected by bacteria before they are exchanged. When the lens baskets are stored in the disposable containers containing disinfection liquid, the lens baskets may be considered to be sterile until the moment when the seal is torn off.

When the means to receive the contact lenses are formed by disposable lens baskets, as stated in claim 4, the use of the disinfection system of the invention ensures that

the contact lenses may always be disinfected in an environment which is not infected by bacteria beforehand.

5 When the means to receive the contact lenses are arranged on a stem whose free end protrudes from the disinfection liquid level, as stated in claim 4, it is ensured that contact between the user's fingers and the disinfection liquid in the disposable container is reduced to a minimum.

10

When the disposable container is additionally provided with a removable lid fitting tightly along the rim thereof, as stated in claim 5, it is moreover ensured that the disinfection takes place in a closed environment, and that it is possible to store the contact lenses
15 in the disposable container for an extended period of time, like with the use of the known lens cases. The difference, however, is that the user can decide that also the lid is just to be used once like the disposable container and the disposable lens baskets. This provides a complete disposable disinfection system which eliminates all the drawbacks of the known all-in-one systems at the same time. The user may freely decide to exchange the lens baskets and the tight-fitting lid after each disin-
20 fection or not, as both lens baskets and lids may be used again. The system is conceivably designed such that disposable containers may be purchased with and without lens baskets, and with and without lids.

30 Also, as stated in claim 6, the disposable container may be constructed such that it may be placed as a disposable insert in a container of a lens case, following which the seal across the opening is torn off prior to the mounting of the lid with the lenses in the lens baskets. The additional advantages of this are that the lens case con-
35 tainer, which usually consists of a cylindrical transpar-

ent container of impact-proof plastics, and which takes more resources to manufacture than the disposable container, does not have to be exchanged with the common frequency, as it does not contact the disinfection liquid and is thus not subjected to bacterial attacks. Further, the lens case container is used for protecting the disposable container.

The disposable container of the invention containing means to receive the contact lenses or holding means (disposable lens basket) for these finds application as an insert in primitive lens cases which do not comprise a lens basket, as stated in claim 7.

Also special lens cases may be constructed, whose shape is adapted for use together with disposable containers of the invention, as stated in claim 8, the container of the lens case being used for receiving a disposable container containing disinfection liquid into which the lens baskets with the contact lenses are immersed when the lid is screwed on to the lens case.

The protruding flange on the disposable container, stated in claim 9, provides a tight connection between the lid of the lens case and the disposable container, so that the container of the lens case is not contaminated by bacteria from the contact lenses, as the interior thereof does not get in contact with the disinfection liquid of the disposable container. The container of the lens case is thus used for securing and protecting the disposable container in the correct position below the lens baskets, as well as an additional protection against bacterial attacks.

The disinfection system of the invention is moreover extremely useful in connection with the use of the system,

comprising a first cleaning in hydrogen peroxide (H_2O_2) and a subsequent neutralization in a neutralization liquid, as the user is always certain of how far he has got in the disinfection process, since the disposable containers are discarded as they are used. Thus, if the contact lenses are being disinfected in H_2O_2 , the disposable container containing the neutralization liquid will be juxtaposed with unbroken seal, thereby enabling it to be observed that the neutralization process has not been completed. A further safeguard against wrong use of disinfection liquid and neutralization liquid may comprise providing the disposable containers for the respective liquids with mutually different colours and/or shapes, as stated in claim 10. This minimizes the risk of inserting non-neutralized contact lenses when using the disposable containers according to the invention.

The containers containing H_2O_2 and neutralization liquid, respectively, may have different shapes and appearances, and the upper sides of the seals thereof may be provided with marks clearly indicating what the containers contain, thereby reducing the risk of mistakes.

Of course, the disposable containers are relatively small, as they are intended to be accommodated in the container part of the lens case. This means that these occupy very little space, and as a result the new distribution system, in addition to the advantages already mentioned, also has the same advantages with respect to space requirement as the known all-in-one disinfection liquids which are supplied in unit dose packages.

The invention will be explained more fully below with reference to the drawing, in which

fig. 1 is a perspective view of an unopened disposable container with a lid,

5 fig. 1A is lateral sectional view of fig. 1, containing disposable lens baskets,

fig. 2 is a perspective view of fig. 1A, with partly removed seal,

10 fig. 3 is an exploded lateral view of fig. 2 during insertion of contact lenses into the disposable lens baskets,

15 fig. 3A shows the disposable container used as an insert in a primitive lens case,

fig. 4 is a lateral sectional view of the disposable container in an assembled state,

20 fig. 5 shows the disposable container during removal of the tear-off sheet,

25 fig. 6 is a lateral sectional view of the disposable container used as an insert in a normal lens case,

fig. 7 is a perspective view of a lens case to receive disposable containers, and fig. 8 is a lateral sectional view of a lens case with inserted disposable container during cleaning of contact lenses.

30

The disinfection system 1 of the invention is shown in fig. 1 in an unopened state and comprises a disposable container 18 with a tear-off sheet seal 22 secured on an annular flange 26 (fig. 2). The disposable container 18
35 is formed with such a wide mouth as to be suitable to re-

ceive holding means 14, 19 for contact lenses 16 during the disinfection process.

As shown in fig. 1A, a removable, tight-fitting lid 28
5 may be provided along the rim of the disposable container above the sheet seal 22. Further, the disposable container 18, in addition to the disinfection liquid 24, may also contain a set of lens baskets 19 secured to a stem 21, whose free end protrudes above the disinfection
10 liquid level.

When the disinfection system 1 is to be used, the lid 28 is removed from the disposable container 18, and then the sheet seal 22 is torn off (fig. 2). Then, the stem 21 is
15 grasped by the finger tips and the lens baskets 19 are lifted out of the disposable container 18. The contact lenses 16 are then placed in the lens baskets 19, as appears from fig. 3, and these are immersed into the disposable container 18 by again grasping the free end of
20 the stem 21 by the finger tips. The lid 28 is applied over the opening of the disposable container (fig. 4), and the disinfection process takes place.

The disposable container 18 may also be used as an insert
25 in a simple lens case 3, without lens basket, as appears from fig. 3A. This embodiment of the disinfection system does not comprise the lid 28, the protruding flange 26 on the disposable container 18 being clamped between the rim of the lens case 5 and a sealing member 13, cooperating
30 with it, in the form of an O-ring seal on the lid 7 of the lens case. Placing of the contact lenses 16 in the lens baskets 19 in connection with the disinfection process takes place as described before.

35 The embodiment of the disinfection system 1 shown in fig. 5 for use together with traditional lens cases, with lens

baskets 14 secured to a stem 15 whose free end is secured in the lens case lid 8, comprises a disposable container 18 with the tear-off sheet seal 22 described before. In use, as disclosed in fig. 6, the disposable container 18 is placed in the container 4 of the lens case, before or after the sheet seal 22 is torn off. The contact lenses 16 are then placed in the lens baskets 14, and the lid 8 is applied to the container 4, whereby the lens baskets 14 containing the contact lenses 16 are immersed into the disinfection liquid 24. Application of the lid 8 causes the protruding annular flange 26 to be clamped between the rim of the container 4 and a sealing member 13, cooperating with it, in this case an O-ring on the lid 8.

A lens case 2 for use together with the disinfection system 1 of the invention is shown in a disassembled state in fig. 7. The lens case 2 consists of two main parts, a container 4 whose external rim has bayonet threads 6 to enable the lid 8 to be screwed on.

As appears from fig. 7, the inner side of the lid 8 has a plurality of gripping flaps 10 intended to engage the bayonet threads 10 on the container 4. An inner side 11 of the bottom of the lid is formed with an annular groove 12 in which a seal 13, in this case an O-ring, of a suitable material is embedded. The O-ring 13 is so positioned in the lid 8 that when the lid is screwed on to the container 4, the O-ring engages the upper edge of the container. As appears from fig. 8, the underside of the lid 8 has two lens baskets 14 carried by a stem 15 which is inserted into the central hole 9 of the lid, said baskets being intended to receive a set of contact lenses 16. When the lid 8 is screwed firmly on to the container 4, the lens baskets 14 extend down into the interior of the container.

Fig. 7 additionally shows two containers 18, 20 in the shape of a cup having an annular flange 26 along the rim. One container 18 has an intact seal in the form of a tear-off sheet 22. The tear-off sheet 22 is removed on
5 the other container 20, which contains disinfection liquid 24. The cups 18, 20 are shaped such that they may be received in the container 4, so that the annular flange 26 engages the upper edge of the container. In the applied position of the case lid 4, the O-ring engages
10 the annular flange 26 on the disposable container 20 (fig. 8), thereby forming a tight connection between the container 20 and the lid 8. In the same position, the lens baskets 14 extend down into the liquid in the container 20.

15

Disinfection of contact lenses 16 takes place by placing these in the lens baskets 14, following which the disposable container 20 is placed in the container 4, and the sheet 22 across the mouth on the disposable container 20
20 is torn off. The lid 8 is then threaded on to the container, thereby causing the lens baskets 14 containing the contact lenses 16 to be immersed into the disinfection liquid 24 which is present in the container 20, and which has maintained its optimum effect till now. After
25 completed treatment, the lid 8 is screwed off the container 4, and the disposable container 20 with the spent liquid is discarded. If a two-liquid disinfection system is used, the container with the neutralization liquid is then inserted into the container 4 after tearing-off of
30 the disposable sheet 22, and the lid 8 is screwed on again, following which the neutralization process takes place.

If the user of the contact lenses is particularly careful
35 with the cleaning of his lenses, the lenses are rubbed before being disinfected. The mechanical action results

in a better cleaning of the bacterial film and of other impurities on the lenses than the disinfection which takes place merely by immersing the lenses into disinfection liquid. A little liquid is necessary for the rubbing, which is performed by a finger. The spent liquid from the preceding disinfection may be used for this purpose, or sterile brine. As the lid and container of the lens case are sealed, it is thus possible to store the liquid after the disinfection until rubbing is to be performed. After rubbing, the disposable container with the spent liquid is discarded, a new one is inserted, and the actual disinfection of the contact lenses takes place.

It is common to the use of the disinfection system 1 of the invention that both the disposable container 18 and the spent disinfection liquid 24 present in the container are discarded after the completion of the disinfection of the contact lenses 16.

If the disinfection system 1 also comprises holding means in the form of lens baskets 19 as well as a cover 28, these parts are discarded together with the container 18 and the spent disinfection liquid 24. If the user does not want to exchange the cover 28 and the lens baskets 19 after each disinfection of contact lenses, these parts may be used again together with the embodiment of the disinfection system which does not comprise these parts. Hereby, precisely the exchange frequency of lens baskets 19 and cover 28 desired by the user, may be achieved.

As an additional safeguard against contamination in connection with the disinfection process, the cover 28 may also be provided with a tear-off film on the side facing the container mouth, said film being removed immediately before the application of the cover on the container.

Thus, the described disinfection system provides a method of ensuring that the correct amount of disinfection liquid is used for the disinfection of contact lenses, thereby eliminating the danger of bacterial growth in the case container.

The use of the method and the lens case of the invention in connection two two-liquid disinfection systems reduces the risk of inserting non-neutralized contact lenses practically to zero, as the user can always observe how far he is in the cleaning process on the basis of the shape and colour of the containers.

If the disposable containers, containing H₂O₂ and neutralization liquid, respectively, are made of a material of different appearance and/or shape, e.g. with different colours, the risk of inserting non-neutralized contact lenses is reduced additionally, as the user, by looking at the disposable container, can see what it contains (e.g. red container contains H₂O₂, and green container contains neutralization liquid). The different container colours are relevant particularly where the user has torn off the seal on both containers at the same time, it being of paramount importance to the user to know which container contains which.

What remains is thus how to keep the lid 8 and the lens baskets 14 free of bacteria in the lens case 2 for use together with the disinfection system 1. However, exchange of the baskets will hardly be necessary, as the disinfection takes place in liquid with unreduced strength. As an additional safeguard, the lid 8, the O-ring 13 and the lens baskets 14 may be made of a material resistant to boiling, thereby allowing these to be boiled, optionally in a weak brine solution, which kills

the bacterial cultures that might have survived the disinfection with the disinfection liquid.

The disposable containers may be made with a quite small
5 thickness in an inexpensive manner, e.g. as vacuum formed
sheet elements, as these will be protected by the container of the lens case in use. Further, they are usually
supplied in multi-unit boxes with a suitable strong package
10 optionally formed as a dispenser, or suitable in such
a one, suspended from a wall or the like.

It is contemplated that the containers 18 of the disinfection system and the lens baskets 19, 14 as well as the
special lens case 2 are made of recyclable plastics materials
15 to the greatest possible extent.

P A T E N T C L A I M S :

1. A disinfection system (1) for disinfection of contact lenses (16) and comprising a sealed disposable package (18) containing a suitable amount of disinfection liquid (24) to disinfect a set of contact lenses, c h a r a c -
t e r i z e d in that the disposable package is formed by a disposable container (18) formed with such a wide mouth as to be suitable for receiving holding means for contact lenses (16), said disposable container (18) being used as a disinfection container in connection with the disinfection of the contact lenses (16).
2. A disinfection system (1) according to claim 1, c h a r a c t e r i z e d in that the disposable container (18), at the opening, has an annular flange (26) on whose upper side a tear-off sheet seal (22) is attached in the unopened state of the disposable container.
3. A disinfection system (1) according to claims 1 and 2, c h a r a c t e r i z e d in that the disposable container (18) also holds means to receive the contact lenses (16) or holding means for these.
4. A disinfection system (1) according to claims 1-3, c h a r a c t e r i z e d in that the means to receive the contact lenses are formed by a set of disposable lens baskets (19) arranged on a stem (21) whose free end protrudes above the disinfection liquid level.
5. A disinfection system (1) according to claims 1-4, c h a r a c t e r i z e d in that a removable cover (28) fitting tightly along the rim of the disposable container is provided above the tear-off sheet seal (22) of the disposable container, said cover (28) being reapplied and

used as a lid during disinfection of the contact lenses (16).

5 6. A disinfection system (1) according to claims 1 and 2 for use together with a lens case (2) comprising a container with a lid (4) with lens baskets (14) extending down into the container when the lid is mounted on the container, c h a r a c t e r i z e d in that the disposable container (18) is formed so as to be useful as an
10 insert in the container (4) of the lens case.

7. A disinfection system (1) according to claims 1-4 for use together with a lens case (3) comprising a container (5) with a tight-fitting lid (7), c h a r a c t e r -
15 i z e d in that the disposable container (18) is formed so as to be useful as an insert in the container (5) of the lens case.

8. A lens case (2) for use together with the disinfection system of claims 1 and 2, comprising a container (4) with a lid (8) with lens baskets (14) which extend down into the container when the lid has been screwed on, c h a r a c t e r i z e d in that the container part (4) of the lens case is formed to receive a disposable container (18) according to claims 1 and 2, and that the lid
20 part (8) of the lens case is formed so that when it is mounted on the container (4), the lens baskets (14) extend down into the disposable container (18).

30 9. A disinfection system (1) according to claims 1, 2, 3, 4, 5, 6, 7 and 8, c h a r a c t e r i z e d in that the protruding flange (26) may be clamped between the rim of a container (4) of a lens case and a sealing member (13) on the lid (8) cooperating therewith.

35

10. A disinfection system (1) according to claims 1-9,

c h a r a c t e r i z e d in that disposable containers containing disinfection liquid (24) and neutralization liquid, respectively, are formed with mutually different colours and/or shapes.

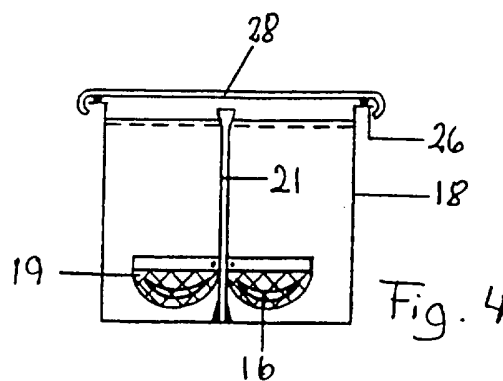
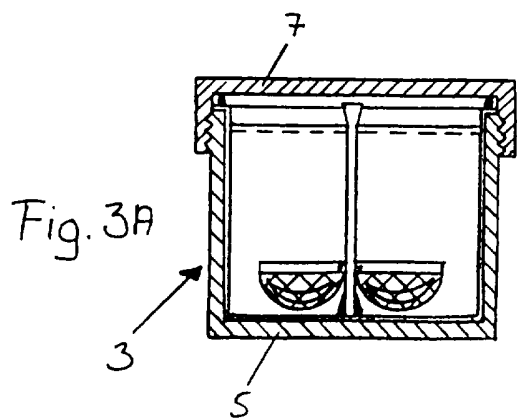
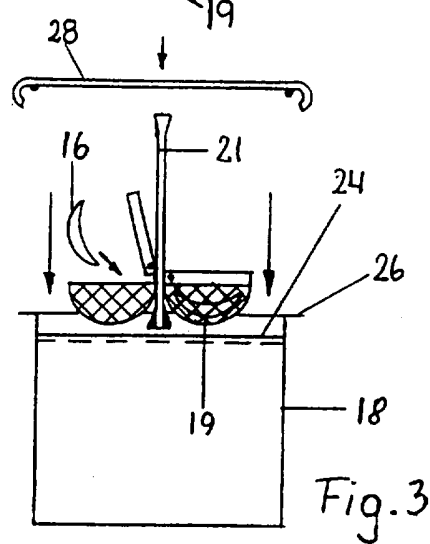
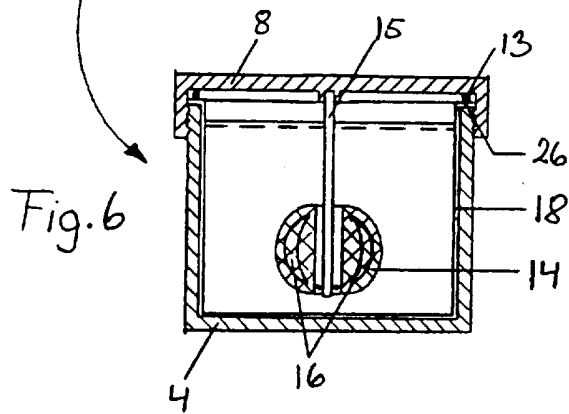
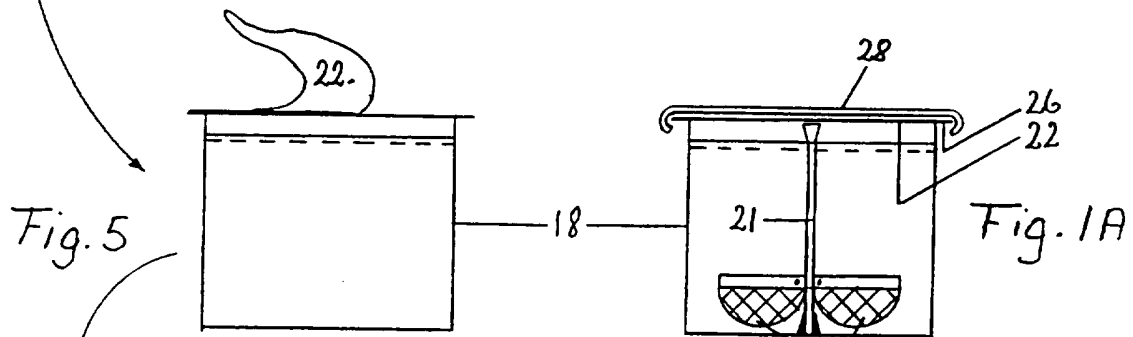
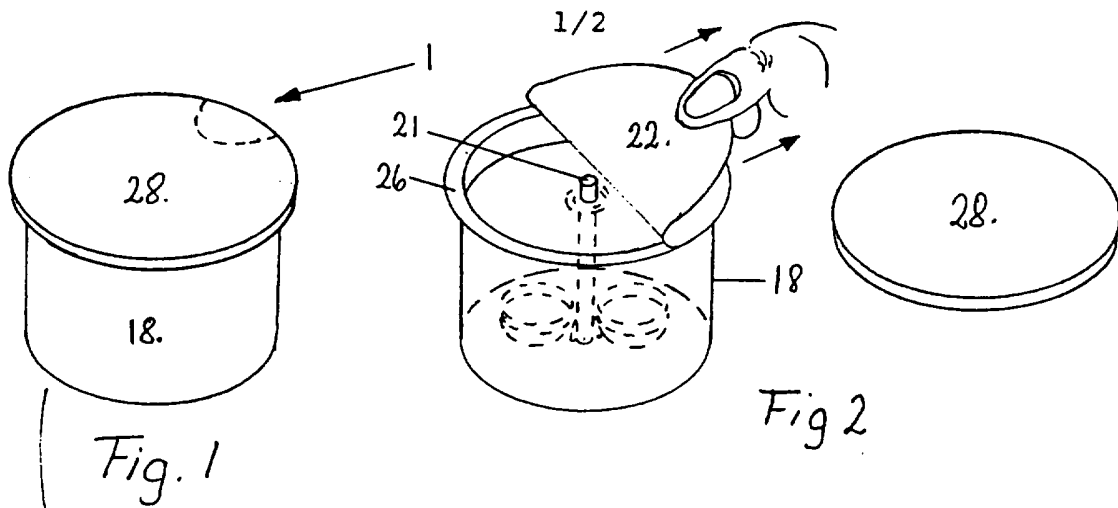

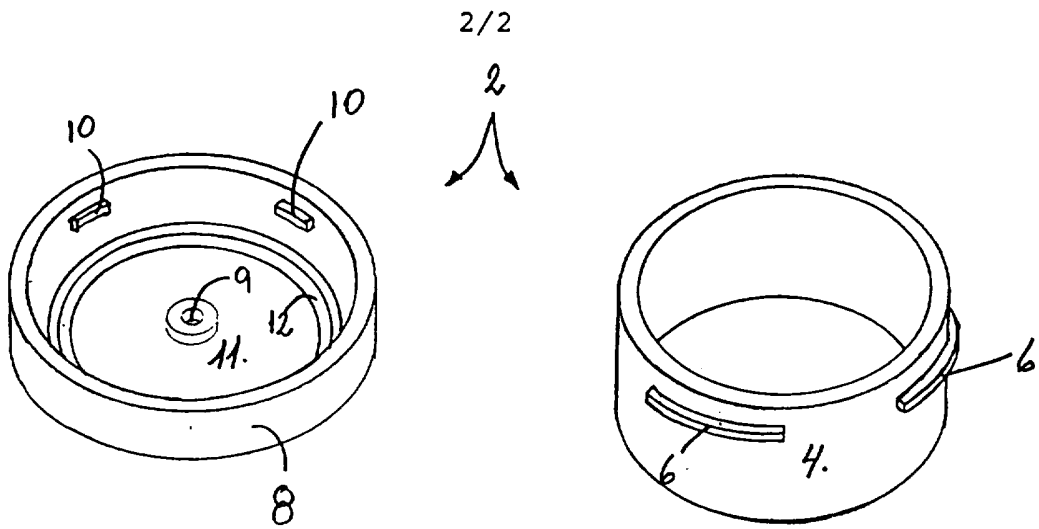

Fig. 7

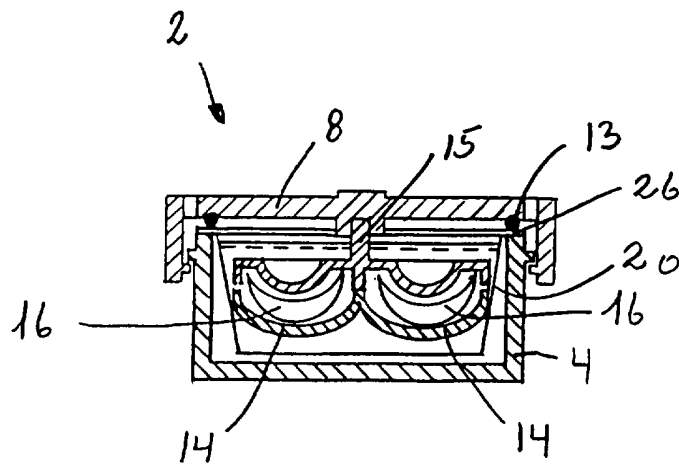
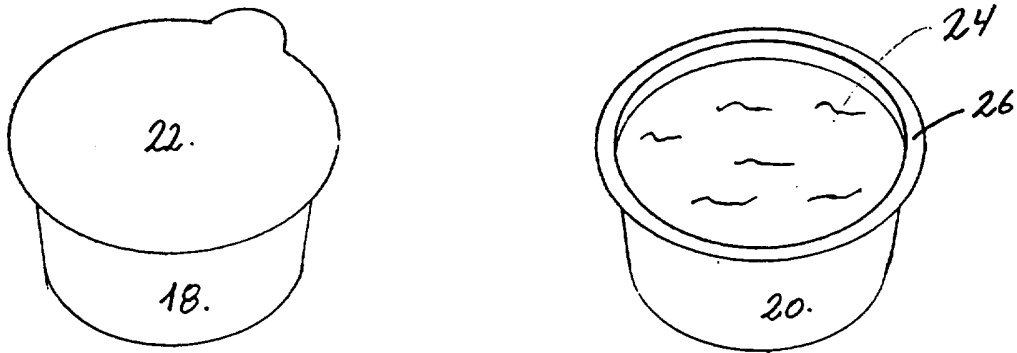

Fig. 8

INTERNATIONAL SEARCH REPORT

International application No.

PCT/DK 96/00036

A. CLASSIFICATION OF SUBJECT MATTER

IPC6: B65D 81/22, A61L 2/18, G02C 13/00

According to International Patent Classification (IPC) or to both national classification and IPC

B. FIELDS SEARCHED

Minimum documentation searched (classification system followed by classification symbols)

IPC6: B65D, A61L, G02C

Documentation searched other than minimum documentation to the extent that such documents are included in the fields searched

SE,DK,FI,NO classes as above

Electronic data base consulted during the international search (name of data base and, where practicable, search terms used)

WPI, CLAIMS

C. DOCUMENTS CONSIDERED TO BE RELEVANT

Category*	Citation of document, with indication, where appropriate, of the relevant passages	Relevant to claim No.
X	US 5375698 A (EWART ET AL), 27 December 1994 (27.12.94), column 2, line 16 - line 45, figures 1, 3,4	1-2
Y	--	3-5
X	EP 0401163 A1 (CIBA-GEIGY AG), 5 December 1990 (05.12.90), figures 1,3, abstract	1-2
X	EP 0381616 A1 (CIBA-GEIGY AG), 8 August 1990 (08.08.90), figure 1, abstract	1-2
	--	

 Further documents are listed in the continuation of Box C. See patent family annex.

* Special categories of cited documents:

"A" document defining the general state of the art which is not considered to be of particular relevance

"E" earlier document but published on or after the international filing date

"L" document which may throw doubts on priority claim(s) or which is cited to establish the publication date of another citation or other special reason (as specified)

"O" document referring to an oral disclosure, use, exhibition or other means

"P" document published prior to the international filing date but later than the priority date claimed

"T" later document published after the international filing date or priority date and not in conflict with the application but cited to understand the principle or theory underlying the invention

"X" document of particular relevance: the claimed invention cannot be considered novel or cannot be considered to involve an inventive step when the document is taken alone

"Y" document of particular relevance: the claimed invention cannot be considered to involve an inventive step when the document is combined with one or more other such documents, such combination being obvious to a person skilled in the art

"&" document member of the same patent family

Date of the actual completion of the international search

6 June 1996

Date of mailing of the international search report

107 -06- 1996

Name and mailing address of the ISA/
Swedish Patent Office
Box 5055, S-102 42 STOCKHOLM
Facsimile No. +46 8 666 02 86

Authorized officer

KERSTIN BRINKMAN

Telephone No. +46 8 782 25 00

INTERNATIONAL SEARCH REPORT

International application No.

PCT/DK 96/00036

C (Continuation). DOCUMENTS CONSIDERED TO BE RELEVANT		
Category*	Citation of document, with indication, where appropriate, of the relevant passages	Relevant to claim No.
Y	US 5181604 A (OHTA ET AL), 26 January 1993 (26.01.93), column 7, line 21 - line 32, figure 4, abstract --	3-5
A	EP 0560728 A1 (CIBA-GEIGY AG), 15 Sept 1993 (15.09.93), figure 17, abstract -- -----	1-10

INTERNATIONAL SEARCH REPORT

Information on patent family members

International application No.

01/04/96

PCT/DK 96/00036

Patent document cited in search report	Publication date	Patent family member(s)	Publication date
US-A- 5375698	27/12/94	AU-A- 6638694	08/11/94
		CA-A- 2160485	27/10/94
		EP-A- 0694017	31/01/96
		WO-A- 9424019	27/10/94
EP-A1- 0401163	05/12/90	AT-T- 118355	15/03/95
		AU-B,B- 624715	18/06/92
		AU-A- 5609590	06/12/90
		CA-A- 2017691	30/11/90
		DE-D- 69016836	00/00/00
		JP-A- 3013913	22/01/91
		US-A- 5054610	08/10/91
		EP-A1- 0381616	08/08/90
AU-B,B- 618656	02/01/92		
AU-A- 4799690	09/08/90		
CA-A- 2008768	31/07/90		
DE-D,T- 69004701	17/03/94		
IE-B- 63089	22/03/95		
JP-A- 2289254	29/11/90		
US-A- 5053208	01/10/91		
US-A- 5181604	26/01/93	DE-D,T- 69112324	29/02/96
		EP-A,A,A 0476937	25/03/92
		JP-A- 3295347	26/12/91
EP-A1- 0560728	15/09/93	AU-A- 3407493	16/09/93
		CA-A- 2091531	14/09/93
		JP-A- 6007414	18/01/94
		US-A- 5468448	21/11/95