



- (51) International Patent Classification:  
*H01R 25/00* (2006.01)      *H01R 13/66* (2006.01)
- (21) International Application Number:  
PCT/US2017/042046
- (22) International Filing Date:  
14 July 2017 (14.07.2017)
- (25) Filing Language: English
- (26) Publication Language: English
- (30) Priority Data:  
62/365,125      21 July 2016 (21.07.2016)      US
- (71) Applicant: CANARY CONNECT, INC. [US/US]; 132 East 43rd Street, Ste. 552, New York, NY 10017 (US).
- (72) Inventors; and  
(71) Applicants: BLAKE, Robert [US/US]; 132 East 43rd Street, Ste. 552, New York, NY 10017 (US). RAO,

Matthew [US/US]; 132 East 43rd Street, Ste. 552, New York, NY 10017 (US). YE, David [US/US]; 132 East 43rd Street, Ste. 552, New York, NY 10017 (US).

(74) Agent: O'SULLIVAN, William, P.; Sheehan Phinney Bass & Green PA, 1000 Elm Street, 17th Floor, Manchester, NH 03101 (US).

(81) Designated States (unless otherwise indicated, for every kind of national protection available): AE, AG, AL, AM, AO, AT, AU, AZ, BA, BB, BG, BH, BN, BR, BW, BY, BZ, CA, CH, CL, CN, CO, CR, CU, CZ, DE, DJ, DK, DM, DO, DZ, EC, EE, EG, ES, FI, GB, GD, GE, GH, GM, GT, HN, HR, HU, ID, IL, IN, IR, IS, JO, JP, KE, KG, KH, KN, KP, KR, KW, KZ, LA, LC, LK, LR, LS, LU, LY, MA, MD, ME, MG, MK, MN, MW, MX, MY, MZ, NA, NG, NI, NO, NZ, OM, PA, PE, PG, PH, PL, PT, QA, RO, RS, RU, RW, SA, SC, SD, SE, SG, SK, SL, SM, ST, SV, SY, TH, TJ, TM, TN, TR, TT, TZ, UA, UG, US, UZ, VC, VN, ZA, ZM, ZW.

(54) Title: REVERSIBLE POWER AND DATA CONNECTOR ASSEMBLY

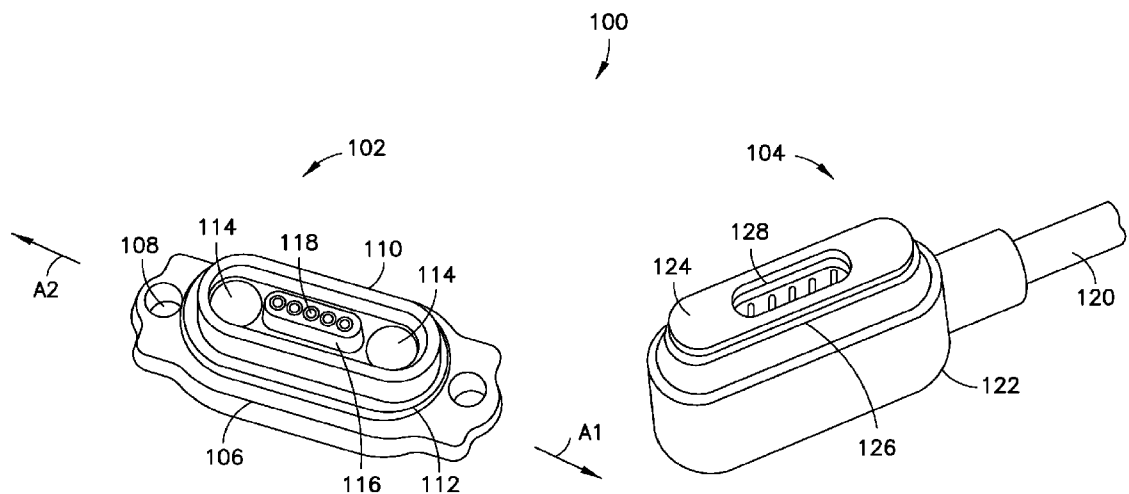

FIG. 1

(57) Abstract: A system includes a first electrical connector and a first multiplexer. The first electrical connector has multiple electrical contacts including at least a first data contact, a second data contact, a first power contact and a second power contact. The first multiplexer has a first data input, a second data input and a selector. The first data input is coupled to the first data contact. The second data input is coupled to the second data contact. The selector is coupled to the first power contact or the second power contact. The first multiplexer is configured to; direct the first data input to a first bus and direct the second data input to a second bus, or direct the first data input to the second bus and direct the second data input to the first bus, depending whether a voltage is present at the selector.



**(84) Designated States** (*unless otherwise indicated, for every kind of regional protection available*): ARIPO (BW, GH, GM, KE, LR, LS, MW, MZ, NA, RW, SD, SL, ST, SZ, TZ, UG, ZM, ZW), Eurasian (AM, AZ, BY, KG, KZ, RU, TJ, TM), European (AL, AT, BE, BG, CH, CY, CZ, DE, DK, EE, ES, FI, FR, GB, GR, HR, HU, IE, IS, IT, LT, LU, LV, MC, MK, MT, NL, NO, PL, PT, RO, RS, SE, SI, SK, SM, TR), OAPI (BF, BJ, CF, CG, CI, CM, GA, GN, GQ, GW, KM, ML, MR, NE, SN, TD, TG).

**Published:**

— *with international search report (Art. 21(3))*

## REVERSIBLE POWER AND DATA CONNECTOR ASSEMBLY

### CROSS-REFERENCE TO RELATED APPLICATIONS

This application claims the benefit of priority to U.S. Provisional Patent Application No. 62/365,125, entitled, *REVERSIBLE POWER AND DATA CONNECTOR ASSEMBLY*, which was  
5 filed on July 21, 2016. The disclosure of the prior application is incorporated by reference herein in its entirety.

### FIELD OF THE INVENTION

This disclosure relates to a power and data connector assembly and, more particularly, relates to a power and data connector assembly that is reversible (i.e., where the two connectors  
10 involved can be connected together in any one of at least two different orientations).

### BACKGROUND

An electrical connector is an electro-mechanical device used to join electrical terminations to create an electrical circuit. Generally speaking, each electrical connection consist  
15 of a male-style connector (e.g., a plug) mated with a female-style connection (e.g., a socket).

There are many different types of electrical connectors and they can be classified or described in a variety of different ways, including, for example, by their pinout design, physical configuration, overall size, contact resistance, insulation between pins, ruggedness, resistance to vibration, resistance to entry of water and/or other contaminants, resistance to pressure,  
20 reliability, number of connect/disconnect operations before failure, ease of connecting and disconnecting, etc.

Electrical connectors can be used in a variety of different applications and locations.

## SUMMARY OF THE INVENTION

In one aspect, a system includes a first electrical connector and a first multiplexer. The first electrical connector has multiple electrical contacts including at least a first data contact, a second data contact, a first power contact, and a second power contact. The first multiplexer has a first data input, a second data input and a selector. The first data input is coupled to the first data contact. The second data input is coupled to the second data contact. The selector is coupled to the first power contact or the second power contact. The first multiplexer is configured to: direct the first data input to a first bus and direct the second data input to a second bus, or direct the first data input to the second bus and direct the second data input to the first bus, depending whether a voltage is present at the selector.

In another aspect, a method includes, directing data signals arriving at an electrical component via a reversible electrical connector assembly in a manner that depends on a position of a voltage signal at one or more of the contacts on the electrical connector assembly.

In some implementations, one or more of the following advantages are present.

For example, a power and data connector assembly is easy to connect because the specific orientation of the two connectors is not critical to proper system operation. This can be particularly advantageous in situations where the connection needs to be made (or unmade) in difficult-to-access places. Additionally, the connector assembly is very robust (e.g., waterproof, or weatherproof). It also holds together well (e.g., because of the use of magnets), but comes apart relatively easily (e.g., due to the spring-loaded, i.e., pogo-style, pin design). Moreover, the connector assembly is able to transfer power and data simultaneously.

Other features and advantages will be apparent from the description and drawings, and from the claims.

## BRIEF DESCRIPTION OF THE DRAWINGS

FIG. 1 is a partial perspective view of an exemplary connector assembly that includes a first electrical connector and a second electrical connector.

5 FIG. 2 is a partial schematic representation of an exemplary electrical component that includes the first electrical connector and internal circuitry.

FIG. 3 is a partial cross-sectional view of an exemplary first electrical connector.

FIG. 4 is a partial cross-sectional view of the exemplary second electrical connector.

10 FIG. 5A and 5B are cross-sectional views showing an exemplary arrangement that includes a first electrical connector mated to a second electrical connector.

FIG. 6A and 6B are perspective views of an exemplary electrical component that includes an exemplary first electrical connector and associated internal circuitry.

Like reference numerals refer to like elements.

## 15 DETAILED DESCRIPTION

This disclosure relates to systems that include a connector assembly having a first electrical connector and a complementary second electrical connector. Each electrical connector has multiple electrical contacts that collectively facilitate the delivery of both power and data through the connector assembly. The arrangement of the electrical contacts and the physical  
20 configuration of each electrical connector allows for the first electrical connector and the second electrical connector to be joined together in any one of at least two different physical orientations.

In a typical implementation, the first electrical connector may be part of an electrical component (e.g., a battery-powered security camera, or the like), and exposed at an external surface of the electrical component. Moreover, in a typical implementation, the second electrical connector may be a connector at the end of cable (e.g., a USB-style cable). This USB-style cable  
5 may be used to plug the electrical component into a USB port of a computer, for example, for charging the electrical component and/or for transferring data into or out of the electrical component.

Generally speaking, the systems disclosed herein are configured so that any power and data that is delivered through the connector assembly (i.e., the first and second electrical  
10 connectors when connected) is automatically routed to an appropriate destination (e.g., within the electrical component) regardless of how the second electrical connector is oriented relative to the first electrical connector when connected. Thus, if data and power may be delivered to different contacts on the first electrical connector depending on the relative orientation of the second electrical connector, the system (e.g., the security camera) will automatically adjust to  
15 ensure that the power and data is appropriately routed inside the camera.

The connector assembly can be waterproof or weatherproof, having integral sealing provisions, and may include one or more magnetic components that facilitate connecting the first and second electrical connectors and/or to help maintain a secure connection between the first and second electrical connectors when connected.

20 The contacts of the connector assembly may be pogo-style contacts. In general, a pogo-style contact is a particular type of spring loaded contact that provides reliable, usually temporary, electrical connection between electrical parts, even in rigorous environments, such as the outdoors.

Advantageously, in a typical implementation, the present disclosure provides for a highly reliable connector assembly for delivery of power and data between electrical parts. Moreover, the connector assembly may be reversible, meaning, for example, that the two parts of the assembly (e.g., a first electrical connector and a second electrical connector) can be connected  
5 together with the parts in any one of more than one physical orientation. The power and data is delivered to appropriate destinations (e.g., within the electrical component) regardless of how the electrical connectors are physically oriented relative to each other when connected.

A typical combination of such features, and various sub-combinations thereof, may be highly desirable in a variety of applications, such as in battery-powered security cameras, or the  
10 like, that may be installed in difficult to reach places and that may need to be at least periodically plugged into a USB-style cable for recharging and/or data transfer purposes. The reversibility of the connectors and the magnetic components help make the electrical connectors easy to connect, which may be particularly important if the connector assembly may be installed in a difficult-to-reach place. The sealed nature of the resulting electrical connection, the magnetic features and  
15 the pogo-style connectors all help ensure a long life and continued proper operation of the connector assembly even in rigorous environments.

FIG. 1 is a partial perspective view of an exemplary connector assembly 100 that includes a first electrical connector 102 and a second electrical connector 104.

Though not shown in FIG. 1, in a typical implementation, the first electrical connector  
20 102 would be physically attached to and exposed at an external surface of an electrical component (e.g., a battery-powered security camera, or the like). The second electrical connector 104, as shown in the illustrated implementation, is attached to the end of a cable 120 (e.g., a USB-style cable).

The connector assembly 100 is reversible, which, according to the illustrated implementation, means that the second electrical connector 104 can be connected to the first electrical connector 102 in any one of multiple orientations: a) with the cable 120 extending in a direction represented by arrow A1, or b) with the cable 120 extending in a direction represented by arrow A2. It should be noted that certain contacts on the second electrical connector 104 will touch different contacts on the first electrical connector 102 depending on which of these orientations is used. Thus, power and/or data may be delivered into different contacts of the first electrical connector 102 depending on the specific orientation of the second electrical connector 104 relative to the first electrical connector 102. As discussed herein, however, the system is generally adapted to ensure that any such power or data is routed to the appropriate destination regardless of the specific orientation used.

The first electrical connector 102 has a base portion 106 with a pair of mounting holes 108 that extend through the base portion 106. The mounting holes 108 are configured to receive mounting screws, or the like, that can be used to secure the first electrical connector 102 to an electrical component.

There is a projection that extends out of the base portion 106 of the first electrical connector 102 to define a wall 110 that is shaped substantially like an obround (or like the cross-section of a capsule). A gasket 112 is provided around the wall 110 where the wall and the base portion 106 meet.

There is a flat surface inside the wall 110 that is recessed relative to the top of the wall 110. There are two magnetic components 114 (e.g., magnets) embedded in this flat surface. In a typical implementation, these magnetic components 114 help make it easy to connect the

second electrical connector 104, which has magnetically attractive parts, to the first electrical connector 102.

There is a contact platform 116, with a plurality of electrical contacts 118 that extends in an upward direction from the center of the flat surface in the first electrical connector 102. The contact platform 116 in the illustrated implementation is shaped substantially like an obround (or like the cross-section of a capsule), too. The electrical contacts 118 are exposed at a top or distal surface of the contact platform 116 for connection to other electrical contacts (e.g., the electrical contacts on the second electrical connector 104).

In the illustrated example, there are five electrical contacts 118 and all five are arranged along a common line and are substantially evenly-spaced. Moreover, in the illustrated implementation, all of the electrical contacts 118 are female pogo-style electrical contacts.

In a typical implementation, each respective one of the electrical contacts 118 is designated for a particular purpose. In one such exemplary implementation, the two outermost electrical contacts are power contacts (either one of which, but typically not both, can be used for the delivery of electrical power to the electrical component), the middle contact 118 is a ground contact, and the two other electrical contacts are data contacts (e.g., to collectively deliver a differential data signal, e.g., from a twisted pair of data lines in a USB-style cable to the electrical component). Thus, the order of electrical contacts in the first electrical connector, from end to end, may be: power, data, ground, data, and power.

Typically, when mounted to the electrical component (not shown in FIG. 1), the base portion 106 of the first electrical connector 102 might sit inside the housing of the electrical component and the wall 110 might extend through an opening in the housing of the electrical component, with the gasket 112 creating a seal against at least an inner surface of the housing.

The second electrical connector 104 is physically attached to the end of a cable 120 (e.g., a USB-style cable). USB, short for Universal Serial Bus, refers to an industry standard that defines the cables, connectors and communications protocols used in a bus for connection, communication, and power supply between computers, electronic devices, for example.

5 Generally speaking, a USB-style cable is any kind of cable that utilizes, is based on, or is similar to USB technology, and that is able to deliver power and data to a destination.

The second electrical connector 104 has a base portion 122 that is shaped substantially like an obround (or like the cross-section of a capsule). A projection portion 124 extends from the base portion 122 and has a similar, but somewhat smaller, shape (also substantially like an  
10 obround, or like the cross-section of a capsule).

A gasket 126 is provided around the projection portion 124 and near a distal end of the projection portion 124. The gasket 126 is configured to seal, when the second electrical connector 104 is attached to the first electrical connector 102, against an inner surface of wall 110 on the first electrical connector 102.

15 There is a flat surface at a distal end of the projection portion 124. In a typical implementation, this flat surface is made of a material that is magnetic and/or attractive to the magnets 114 in the first electrical connector 102.

There is a recess 126 in the flat, distal surface of the projection portion 124. The recess 126 is also shaped substantially like an obround (or like the cross-section of a capsule). There  
20 are multiple electrical contacts 128 exposed within the recess 126 for connection to other electrical contacts (e.g., the electrical contacts on the first electrical connector 102).

In the illustrated example, there are five electrical contacts 128 and all five are arranged along a common line and substantially evenly-spaced. Moreover, in the illustrated implementation, all of the electrical contacts 128 are male pogo-style electrical contacts.

In a typical implementation, each respective one of the electrical contacts 128 in the second electrical connector 104 is designated for a particular purpose. In one such exemplary implementation, at least one of the two outermost electrical contacts is a power contact (and can be used to deliver electrical power), the middle contact is a ground contact, and the two other electrical contacts are data contacts (and can be used to deliver a differential data signal from a twisted pair of data lines in the USB-style cable 120, for example). Thus, the order of electrical contacts, from end to end in the illustrated example, is: power (possibly), data, ground, data, and power (possibly).

The first electrical connector 102 and the second electrical connector 104 are configured so that, when connected to one another, the extension portion 124 of the second electrical connector 104 extends into the space defined by the wall 110 of the first electrical connector 102, the electrical contacts 128 on the second electrical connector 104 engage the contacts 118 on the first electrical connector 102, and the gasket 126 forms a seal between the outer surface of the extension portion 124 and the inner surface of the wall 110.

FIG. 2 is a partial schematic representation of an exemplary electrical component 230 (e.g., a battery-powered security camera) that includes the first electrical connector 102 of FIG. 1 and various internal circuitry. The internal circuitry in the illustrated implementation includes a power multiplexer 232, a USB multiplexer 234, a power supply 240, a central processing unit (CPU) 236, and a microcontroller unit (MCU) 238. As mentioned above, the first electrical connector 102 is generally configured to accommodate the second electrical connector 104 in

any one of two possible orientations. Moreover, depending on the specific orientation, certain contacts from the second electrical connector 104 will touch different contacts on the first electrical connector 102. For example, in the different orientations, the data contacts may be swapped (e.g., between contacts 2 and 4), and power may be delivered to contact 1 or contact 5, but generally not both.

Generally speaking, the internal circuitry is adapted to ensure that electrical power and data are routed appropriately to ensure proper operation of the electrical component 230 regardless of how the second electrical connector might be oriented when it is connected to the first electrical connector 102.

The first electrical connector 102 in the illustrated implementation has five electrical contacts 118. These electrical contacts are numbered 1-5 and respectively correspond to each of the five contacts 118 shown in FIG. 1 in one order from end to end. In the illustrated example, the two outermost electrical contacts 1 and 5 are power (voltage) contacts (either one of which, but generally not both, may be used to deliver electrical power into the electrical component 230). The middle contact 3 is a ground contact. Contacts 2 and 4 are differential data contacts and are configured to receive differential data (e.g., from a twisted pair of data lines in a USB-style cable).

In the illustrated implementation, contact 1 is connected to a first internal power bus USB\_VBUS0, contact 2 is connected to a first internal data bus USB\_DP\_DM, contact 3 is connected to an internal ground bus GND, and contact 4 is connected to a second internal data bus USB\_DM\_DP, and contact 5 is connected to a second internal power bus USB\_VBUS1. Generally speaking, in operation, voltage will appear at either the first internal

power bus USB\_VBUS0 or the second internal power bus USB\_VBUS1, but not both, depending on the specific orientation of a connected second electrical connector.

The power multiplexer 232 can be virtually any kind of electronic circuitry that is configured to select one of several input signals and forward the selected input signal to a single  
5 output, for example. In the illustrated implementation, the power multiplexer 232 is a two-input, one-output power multiplexer.

The power multiplexer 232 has a first input terminal IN1, a second input terminal IN2, a select terminal (SEL), and an output terminal OUT. The first input terminal IN1 is connected to the second internal power bus USB\_VBUS1, and the second input terminal IN2 is connected to  
10 the first internal power bus USB\_VBUS0. The select terminal (SEL) can be connected to either the first internal power bus USB\_VBUS0 or the second internal power bus USB\_VBUS1. The output terminal OUT is connected to a power supply/CPU power bus V\_USB.

The power supply 240 can be virtually any kind of electronic device that is able to supply electrical energy to an electric load (e.g., represented by other sub-components of 230, not shown  
15 in FIG. 1). The primary function of the power supply is to convert one form of electrical energy (i.e., the voltage it receives) to another that is usable by the various sub-components of component 230. The illustrated power supply 240 has a voltage input terminal  $V_{IN}$ .

In the illustrated implementation, the voltage input terminal  $V_{IN}$  of the power supply 240 is connected to the power supply/CPU power bus V\_USB.

20 The USB data multiplexer 234 can be virtually any kind of electronic circuitry that is configured to select one, or more, of several input signals and forward the selected input signal(s) to the outputs, for example. In a simple example, the USB data multiplexer 234 may include internal switches (e.g., normally open or normally closed switches) that can switch based

on the presence or absence of specified voltage(s) at one or more select terminals. The USB data multiplexer 234, in the illustrated implementation, is a low power, dual, single pole, double throw two-port high speed switch.

The USB data multiplexer 234 has a first input terminal COM1, a second input  
5 terminal COM2, a select terminal SEL, a first output terminal NC1, a second output terminal  
NO2, a third output terminal NC2, and a fourth output terminal NO1.

At the input side of the USB multiplexer 234, input terminal COM1 is connected to the  
first data bus USB\_DP\_DM, and input terminal COM2 is connected to the second data bus  
USB\_DM\_DP. The select terminal SEL is connected to the second internal power bus  
10 USB\_VBUS1.

At the output side of the USB multiplexer 234, the first output terminal NC1 and the  
second output terminal NO2 are connected together and connected to a first CPU data bus  
USB\_DP. Also at the output side of the USB multiplexer 234, the third output terminal NC2 and  
the fourth output terminal NO1 are connected together and connected to a second CPU data bus  
15 USB\_DM.

The CPU 236 can be virtually any kind of CPU. Generally speaking, a CPU is  
electronic circuitry that carries out instructions of a computer program by performing various  
operations specified by the instructions. The CPU in the illustrated implementation has a power  
terminal VBUS\_DET, a positive data terminal USB\_D+, and a negative data terminal USB\_D-.

20 The power terminal VBUS\_DET of the CPU 236 is connected to the power  
supply/CPU power bus V\_USB. The positive data terminal USB\_D+ of the CPU 236 is  
connected to the first CPU data bus USB\_DP. The negative data terminal USB\_D- of the CPU  
236 is connected to the second CPU data bus USB\_DP.

The microcontroller unit (MCU) 238 can be virtually any kind of MCU. Generally speaking, an MCU is a small computer on a single integrated circuit containing a processor core, memory, and programmable input/output peripherals. Program memory is often included on chip, as well as a typically small amount of random access memory (RAM). Microcontrollers  
5 are generally designed for embedded applications, and may be used in automatically controlled products and devices.

The illustrated MCU 238 has a first terminal ADC1 and a second terminal ADC2. The first terminal ADC1 on the MCU 238 is connected to the first internal power bus USB\_VBUS0, and the second terminal ADC2 on the MCU 238 is connected to the second internal power bus  
10 USB\_VBUS1.

As discussed below, regardless of second electrical connectors orientation (and regardless, therefore, of whether voltage is being delivered to USB\_VBUS0 or USB\_VBUS1 – generally, it will not be both), voltage will be delivered to both the input terminal  $V_{IN}$  of the power supply 240 and to the VBUS\_DET terminal on the CPU 236. In this regard, the power  
15 multiplexer 232 is operationally configured to output automatically the voltage at input terminal IN1 or the voltage at input terminal IN2. In a typical implementation, the power multiplexer would output either the IN1 voltage or the IN2 voltage depending, for example, on whether a voltage is present at the power multiplexer's select terminal (SEL). Moreover, in a typical implementation, regardless of whether voltage is being delivered to USB\_VBUS0 or  
20 USB\_VBUS1, voltage will be output to the power supply/CPU power bus  $V_{USB}$  and reach both the input terminal  $V_{IN}$  on the power supply and the VBUS\_DET terminal on the CPU.

Additionally, and perhaps more significantly, regardless of second electrical connectors orientation (and regardless, therefore, of the specific orientation of the differential

data signals being delivered to internal data bus USB\_DP\_DM and internal data bus  
USB\_DM\_DP), the differential data signal is appropriately routed, to the correct terminals  
(USB\_D+ and USB\_D- on the CPU 236) with the correct polarity. In this regard, the USB  
multiplexer 234 essentially uses the presence (or absence) of voltage at a particular one of the  
5 power contacts at the first electrical connector 102 (or bus USB\_VBUS1), as sensed at selector  
terminal SEL, to implicitly determine the orientation of the second electrical connector 104  
relative to the first electrical connector 102. From that, the USB multiplexer 234 can effectively  
reverse the polarity of the differential data signals, if needed, for delivery to the CPU, or not.

If, for example, the second electrical conductor were connected to the first electrical  
10 connector 102 in a manner that did not require the multiplexer to reverse data polarity (i.e., so  
that the input intended for the positive data input terminal USB\_D+ of the CPU ends up at  
contact 2 of the first electrical connector 102 and the input intended for the negative data input  
terminal USB\_D- of the CPU ends up at contact 4 of the first electrical connector 102), then  
there would be a voltage at contact 1 of the first electrical connector 102, but no voltage at  
15 contact 5 of the first electrical contact 102.

In this example, the select terminal SEL of the USB multiplexer 234 would not receive a  
voltage signal (because it is electrically connected to contact 5, which, in this example, has no  
voltage). The internal switches of the USB multiplexer 234 would remain in their respective  
normal (i.e., no voltage at the selector terminal SEL) positions – that is, the normally open  
20 switches would remain open and the normally closed switches would remain closed. As such,  
the data presented at the input terminals COM1, COM2 would pass through the normally closed  
internal switches of the USB multiplexer 234 to the output terminals NC1, NC2,  
respectively. Furthermore, that data would continue to pass, along buses USB\_DP and

USB\_DM, respectively, into the data terminals USB\_D+ and USB\_D-, respectively, at the CPU 236, with appropriate polarity.

If, on the other hand, the second electrical conductor were connected to the first electrical connector 102 in a manner that did require the multiplexer to reverse polarity (i.e., so that the input intended for the positive data input terminal USB\_D+ of the CPU ends up at contact 4 of the first electrical connector 102 and the input intended for the negative data input terminal USB\_D- of the CPU ends up at contact 2 of the first electrical connector 102), then there would be a voltage at contact 5 of the first electrical connector 102, but no voltage at contact 1 of the first electrical contact 102.

In this example, the select terminal SEL of the USB multiplexer 234 would receive a voltage signal (because it is electrically connected to contact 5, which, in this example, has voltage). The internal switches of the USB multiplexer 234, therefore, would switch out of their respective normal (i.e., no voltage at the selector terminal SEL) positions – that is, the normally open switches would switch to being closed and the normally closed switches would switch to being open. As such, the data presented at the input terminals COM1, COM2 would pass through the normally open (but now closed) internal switches of the USB multiplexer 234 to the output terminals NC2, NC1, respectively. Furthermore, that data would continue to pass, along buses USB\_DP and USB\_DM, respectively, into the data terminals USB\_D+ and USB\_D-, respectively, at the CPU 236, with appropriate polarity.

Additionally, in the illustrated implementation, voltage would flow from whichever contact (1 or 5) on the first electrical connector 102 that ends up being connected to a voltage source, onto internal power bus USB\_VBUS0 or USB\_VBUS1, and into either ADC1 or ADC2 on the MCU 238.

FIG. 3 is a partial cross-sectional view of the exemplary first electrical connector 102 in FIG. 1.

The first electrical connector 102 has a base portion 106 with a pair of mounting holes 108 that extend through the base portion 106. There is a projection that extends out of the base portion 106 of the first electrical connector 102 to define a wall 110. A gasket 112 is provided around the wall 110 where the wall and the base portion 106 meet. There is a flat surface inside the wall 110 that is recessed relative to the top of the wall 110. There are two magnetic components 114 (e.g., magnets) embedded in this flat surface. There is a contact platform 116 that extends in an upward direction from the flat surface. There are five, in-line, evenly-spaced, female, pogo-style electrical contacts 118 exposed at a top (distal) surface of the contact platform 116. The contact platform 116 in the illustrated implementation is shaped substantially like an obround (or like the cross-section of a capsule), too. The electrical contacts 118 are exposed at a top or distal surface of the contact platform 116 for connection to other electrical contacts (e.g., the electrical contacts on the second electrical connector 104).

FIG. 4 is a partial cross-sectional view of the exemplary second electrical connector 104 in FIG. 1.

The second electrical connector 104 is physically attached to the end of a cable 120 (e.g., a USB-style cable). An overmold 444 made of rubber, or the like, is provided at the interface of the cable 120 and the second electrical connector 104 and essentially creates a water tight seal at that interface. The second electrical connector 104 has a base portion 122 and a projection portion 124 that extends from the base portion 122. A gasket 126 is provided around the projection portion 124 and near a distal end of the projection portion 124. There is a flat surface at a distal (top) end of the projection portion 124. This flat surface is made of a material that is

magnetic and/or attractive to the magnets 114 in the first electrical connector 102. There is a recess 126 in the flat, distal surface of the projection portion 124. There are five, evenly-spaced, in-line, male, pogo-style electrical contacts 128 exposed within the recess 126.

FIG. 5A and 5B are cross-sectional views showing an exemplary arrangement of a first  
5 electrical connector 102 connected to a second electrical connector.

In the illustrated implementation, the first electrical connector 102 is inside and mounted to a housing 542 of an electrical component (e.g., a battery powered security camera, or the like). A portion of the first electrical connector 102 (including the contacts 118 and the magnets 114) are exposed through an opening in the housing for connection to the second electrical connector  
10 104.

The gasket 112 that extends around the wall 110 of the first electrical connector 102 is pressed and creates a seal against an inner surface of the housing 342.

Additionally, the gasket 126 that extends around the projection portion 124 of the second electrical connector 104 is pressed and creates a seal against an inner surface of the wall 110 of  
15 the first electrical connector 110.

The pogo-style electrical contacts 118 and 128 on the first and second electrical connectors 102, 104 are engaged to one another.

The magnets 114 on the first electrical connector 102 are positioned close to (or in contact with), and is attracting, the flat surface 124 of the second electrical connector 104.

FIG. 6A and 6B are perspective views of an exemplary electrical component 642 that  
20 includes an exemplary first electrical connector and associated internal circuitry.

The electrical component in the illustrated example is a battery-operated security camera 642 with an internal, rechargeable battery.

The security camera 642 has a housing 644 that is substantially oblong and capsule-shaped with a flat front surface. There are optical elements exposed at the flat front surface of the housing 644 and an audio element at the top of the housing 644. In a typical implementation, the upper optical element 646 is a camera lens (for an internal camera), the lower optical element  
5 648 is a lens (for an internal motion sensor), and at least one of the middle optical elements 650 is a lens (for an internal ambient light sensor). In a typical implementation, the audio element at the top of the housing is a speaker 652.

There is a button 654 at rear surface of the security monitoring device 102 opposite the flat front surface. The button 654 may be pressed by a user, for example, to prompt start-up of  
10 the device or to prompt the device to take some kind of action. In a typical implementation, this single, simple button may be the only type of user interface component on the security camera 642.

Generally speaking, the security camera is configured to collect data (e.g., images, video and/or sound) from a monitored physical location (i.e., wherever the security monitoring device  
15 ends up being located). In some implementations, the security monitoring device is Bluetooth®-enabled and/or Wi-Fi enabled.

The first electrical connector 102 is shown exposed at the rear surface of the security camera (in FIG. 6B). The first electrical connector 102 in the illustrated example, may be used to charge the device and to pass along device-related data. It also may be used in connection  
20 with manufacturing, programming and/or initial set-up, or troubleshooting. And so, diagnostic data, for example, may come through the first electrical connector 102 as well.

A number of embodiments of the invention have been described. Nevertheless, it will be understood that various modifications may be made without departing from the spirit and scope of the invention.

For example, the precise physical configuration of the first and second electrical  
5 connectors can vary considerably, as long as they are able to be connected to each other in more than one orientation.

The precise pin out (or configuration of contacts) in each of the first and second electrical connectors can vary as well. For example, some implementations can include more than one pair of data contacts and, in those implementations, there may be more than five contacts (e.g., there  
10 may be seven, nine, or more). Also, there may, of course, be an even number of contacts. Additionally, the precise order of contacts from end to end in each of the first and second electrical contacts can vary as well. For example, if there are five contacts, the order of contact-types (from one end to the other) may be: 1) data, power, ground, power data, or 2) power, data, ground, data, power, and 3) a variety of other possibilities.

15 The buses, or other electrical connections or couplings, disclosed herein can be virtually any kind of direct, or indirect conductive path (e.g., wires, traces, contacts, vias, etc.) that allows the flow of electrical energy, whether power voltage or data. Additionally, the concept of coupling or being connected, as used herein, should be construed broadly to include any kind of connection or coupling, whether directly or indirectly (e.g., via other circuit components, etc.).

20 The contacts disclosed herein are arranged in line (i.e., along a common line. However, in some implementations, the contacts may be arranged in other ways (e.g., in an array) and there may be more than two different ways (orientations) that the connectors can be connected in. In

those implementations, the position (i.e., contact) where the voltage arrives may be used (e.g., by one or more multiplexers) to route the data signals appropriately.

Certain terminals, buses and the like have been described herein as input or output buses. This terminology was used for convenience only and should not be construed as limiting.

5 Indeed, in many instances an input terminal or bus may be used for input or output. Similarly, an output terminal or bus may be used for output or input.

The magnets and/or magnetic materials can take on a variety of different configurations. Indeed, in some instances only one magnet may be present. In other implementations, more than two magnets may be present. In some implementations, any magnet(s) may be in the second  
10 electrical connector and not the first. In some implementations, there may be one or more magnets in each of the first and second electrical connectors. In some implementations, the magnets may be omitted entirely.

The seals can be created in a variety of different ways and, in some implementations, may be omitted entirely.

15 The specific type of pins or contacts may be pogo-style pins (as described herein), or virtually any kind of electrical contacts.

The CPU 236 and the MCU 238 have been described as different components. However, they and/or their respective functionalities can be combined or incorporated into one single component.

20 USB cables are mentioned herein throughout as examples of a cable type that may be coupled to the connector described herein. Of course, the connector described herein could be connected to virtually any kind of cable that is able to carry both power and data.

It should be understood that any relative terminology used herein, such as “ upper”, “ lower”, “ above”, “ below”, “ front”, “ rear,” etc. is solely for the purposes of clarity in describing particular implementations and is not intended to limit the scope of what is described here to require particular positions and/or orientations. Accordingly, such relative terminology  
5 should not be construed to limit the scope of the present application.

In various embodiments, some of the subject matter disclosed herein can be implemented in digital electronic circuitry, or in computer-based software, firmware, or hardware, including the structures disclosed in this specification and/or their structural equivalents, and/or in combinations thereof. In some embodiments, some of the subject matter disclosed herein can be  
10 implemented in one or more computer programs, that is, one or more modules of computer program instructions, encoded on computer storage medium for execution by, or to control the operation of, one or more data processing apparatuses (e.g., processors).

Some of the operations described in this specification can be implemented as operations performed by a data processing apparatus (e.g., a processor) using data stored on one or more  
15 computer-readable storage devices or received from other sources. The term “processor” encompasses all kinds of apparatus, devices, and machines for processing data, including by way of example a programmable processor, a computer, a system on a chip, or multiple ones, or combinations, of the foregoing. The apparatus can include special purpose logic circuitry, e.g., an FPGA (field programmable gate array) or an ASIC (application specific integrated  
20 circuit). The apparatus can also include, in addition to hardware, code that creates an execution environment for the computer program in question, for example, code that constitutes processor firmware, a protocol stack, a database management system, an operating system, a cross-platform runtime environment, a virtual machine, or a combination of one or more of them. The

apparatus and execution environment can realize various different computing model infrastructures, such as web services, distributed computing and grid computing infrastructures.

While this specification contains many specific implementation details, these should not be construed as limitations on the scope of any inventions or of what may be claimed, but rather  
5 as descriptions of features specific to particular embodiments of particular inventions. Certain features that are described in this specification in the context of separate embodiments can also be implemented in combination in a single embodiment. Conversely, various features that are described in the context of a single embodiment can also be implemented in multiple  
10 embodiments separately or in any suitable subcombination. Moreover, although features may be described above as acting in certain combinations and even initially claimed as such, one or more features from a claimed combination can in some cases be excised from the combination, and the claimed combination may be directed to a subcombination or variation of a subcombination.

Similarly, while operations are depicted in the drawings and described herein as occurring in a particular order, this should not be understood as requiring that such operations be  
15 performed in the particular order shown or in sequential order, or that all illustrated operations be performed, to achieve desirable results. In certain circumstances, multitasking may be advantageous. Moreover, the separation of various system components in the embodiments described above should not be understood as requiring such separation in all embodiments, and it should be understood that the described components and systems can generally be integrated  
20 together in a single product or component or packaged into multiple different products or components.

Finally, the concepts disclosed herein can be implemented in connection with a wide variety of electrical components, especially ones in which it may be desirable to form a

temporary connection to another component (e.g., a computer or the like for charging and/or data transfer). Some examples of these types of components include: battery-powered cameras, security or safety monitors, sensors of any one or more of the following: light, power, temperature, RF signals, scheduling, time, sound, vibration, motion, pressure, voice, proximity, 5 occupancy, location, velocity, safety, security, fire, smoke, messages, medical conditions, identification signals, humidity, barometric pressure, weight, traffic patterns, power quality, operating costs, power factor, storage capacity, distributed generation capacity, UPS capacity, battery life, inertia, glass breaking, flooding, carbon dioxide, carbon monoxide, ultrasound, infra- red, microwave, radiation, microbes, bacteria, viruses, germs, disease, poison, toxic materials, air 10 quality, lasers, loads, load controls, etc.

Other implementations are within the scope of the claims.

What is claimed is:

1. A system comprising:

a first electrical connector comprising a plurality of electrical contacts including at least a first data contact, a second data contact, a first power contact, and a second power contact;

5 and

a first multiplexer comprising a first data input coupled to the first data contact, a second data input coupled to the second data contact, and a selector coupled to the first power contact or the second power contact;

10 wherein the first multiplexer is configured to: direct the first data input to a first bus and direct the second data input to a second bus, or direct the first data input to the second bus and direct the second data input to the first bus, depending whether a voltage is present at the selector.

2. The system of claim 1, further comprising:

15 a first processor comprising a first data terminal and a second data terminal, wherein the first data terminal is coupled to the first output of the multiplexer, and wherein the second data terminal is coupled to the second output of the multiplexer.

3. The system of claim 1, wherein the first multiplexer further comprises:

20 a first data output (NC1) that is normally closed relative to the first data input;  
a second data output (NO1) that is normally open relative to the first data input;  
a third data output (NC2) that is normally closed relative to the second data input; and  
a fourth data output (NO2) that is normally open relative to the second data input.

4. The system of claim 3, wherein the first data output (NC1) and the fourth data output (NO1) are connected together and form the first output of the multiplexer, and

Wherein the second data output (NO1) and the third data output (NC2) are connected together are form the second output of the multiplexer.

5

5. The system of claim 3, wherein the multiplexer is configured to:

close a connection between the second data output (NO1) and the first data input;

close a connection between the fourth data output (NO2) and the second data input;

10

open a connection between the first data output (NC1) and the first data input; and

open a connection between the third data output (NC2) and the second data input,

in response to a voltage being present at the selector.

6. The system of claim 1, further comprising:

15

a second multiplexer comprising:

a first power input terminal, and

a second power input terminal,

wherein the first power input terminal of the second multiplexer is coupled to the first power contact of the first electrical connector, and

20

wherein the second power input terminal of the second multiplexer is coupled to the second power contact of the first electrical connector.

7. The system of claim 6, wherein the second multiplexer further comprises an output terminal, and

wherein the second multiplexer is operable such that a voltage at either one of the first or second power input terminals passes to the output terminal.

5

8. The system of claim 7, further comprising:

a first processor comprising a power terminal,

wherein the power terminal of the first processor is coupled to the output terminal of the second multiplexer.

10

9. The system of claim 1, further comprising:

a second electrical connector comprising a plurality of electrical contacts including at least a first data contact, a second data contact, a first power contact, and a second power contact,

wherein the first electrical connector is configured to accommodate the second electrical connector in any one of two different physical orientations.

15

10. The system of claim 9, wherein the electrical contacts on each of the first and second electrical connectors is arranged along a line.

20 11. The system of claim 9, wherein there are five electrical contacts on each of the first and second electrical connectors.

12. The system of claim 11, wherein the electrical contacts on each of the first and second electrical connectors includes: two data contact, two power contacts and a ground contact.

13. The system of claim 9, wherein the electrical contacts on the first and second electrical  
5 connectors are spring loaded electrical contacts.

14. The system of claim 13, further comprising:

a magnet to facilitate connecting the first and second electrical connectors and/or to help  
maintain a secure connection between the first and second electrical connectors when connected.

10

15. The system of claim 13, further comprising:

a gasket to form a seal between the first electrical connector and the second electrical  
connector when connected.

15

20

1/6

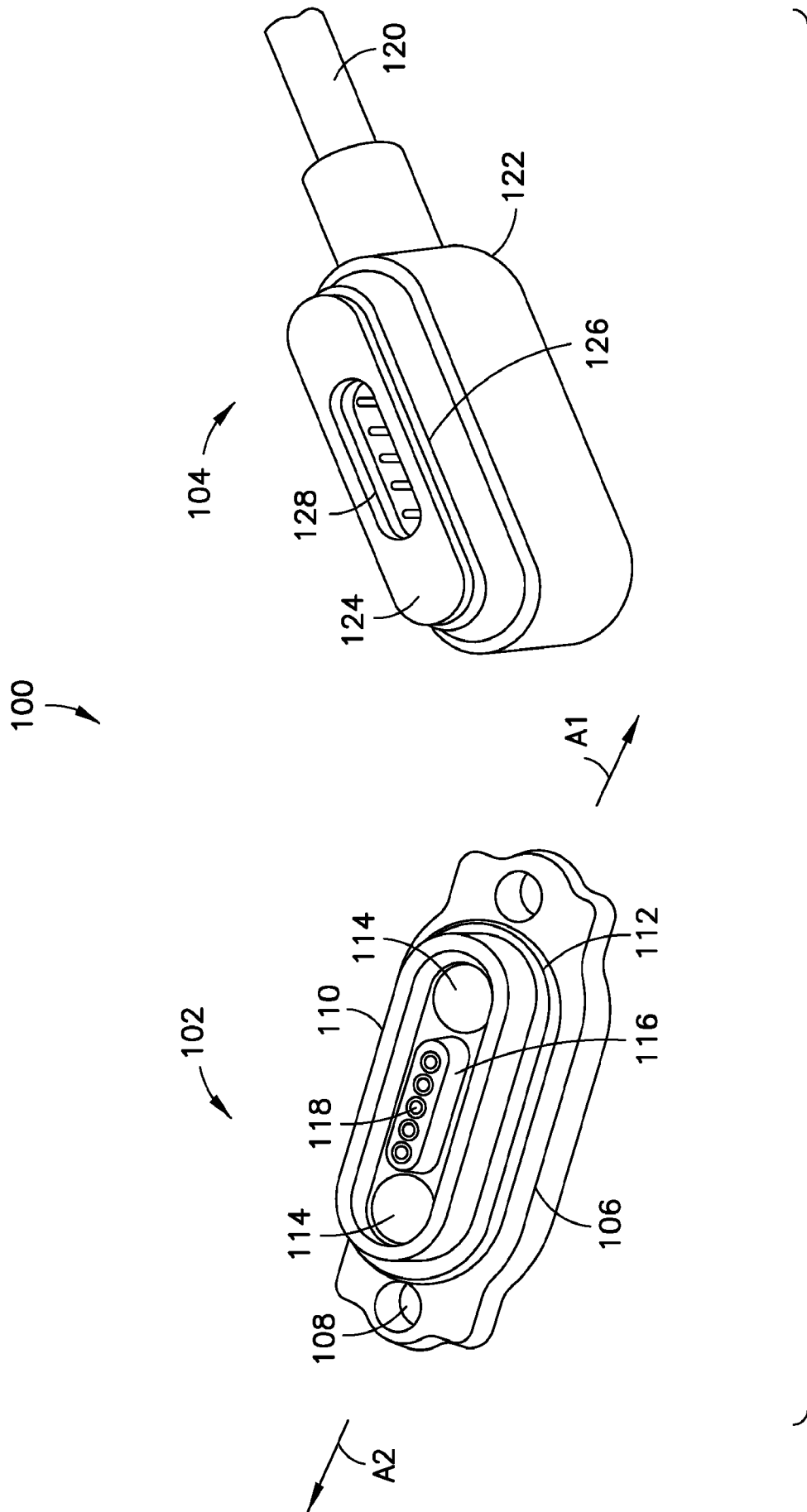

FIG.1

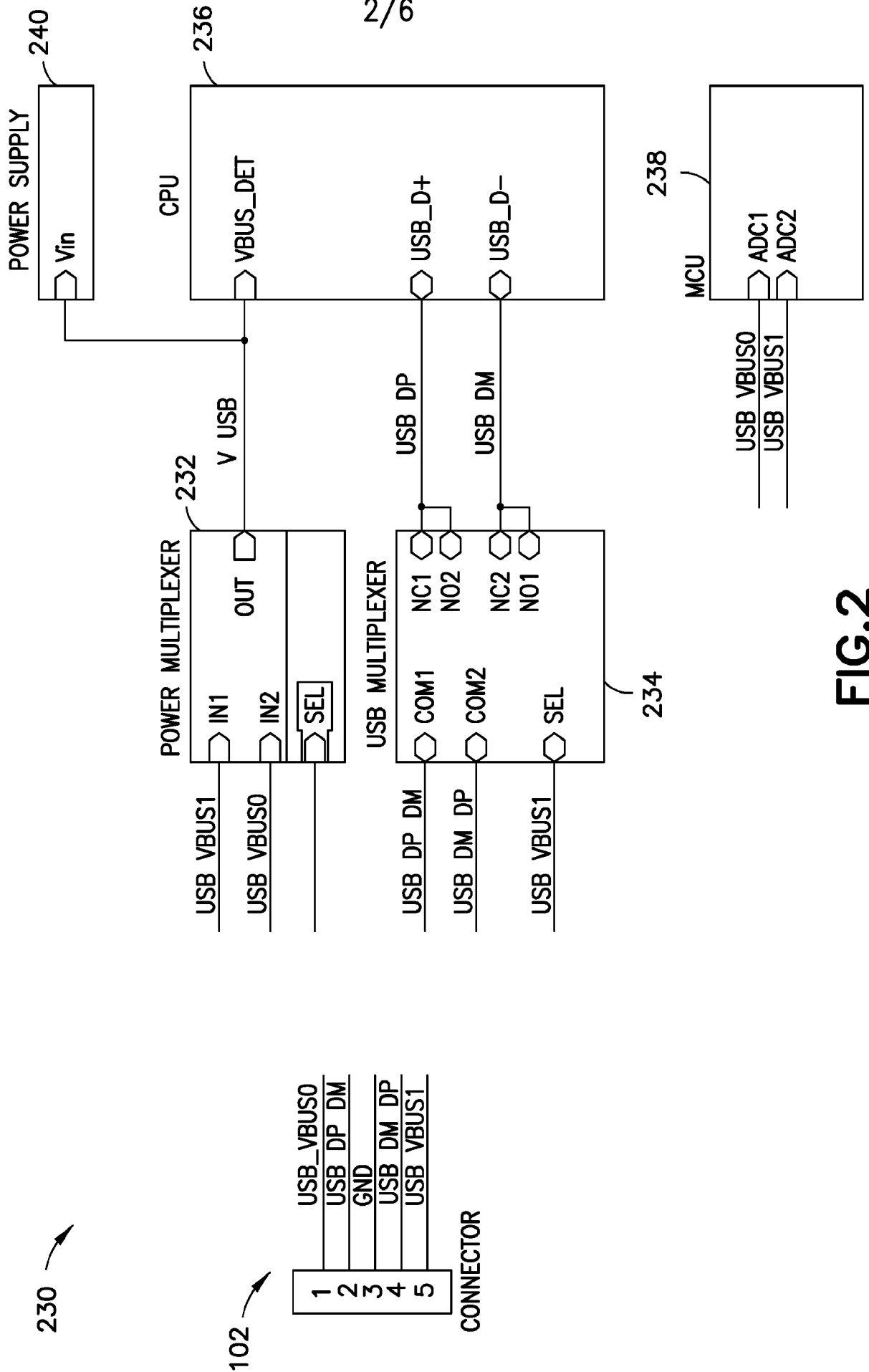

FIG. 2

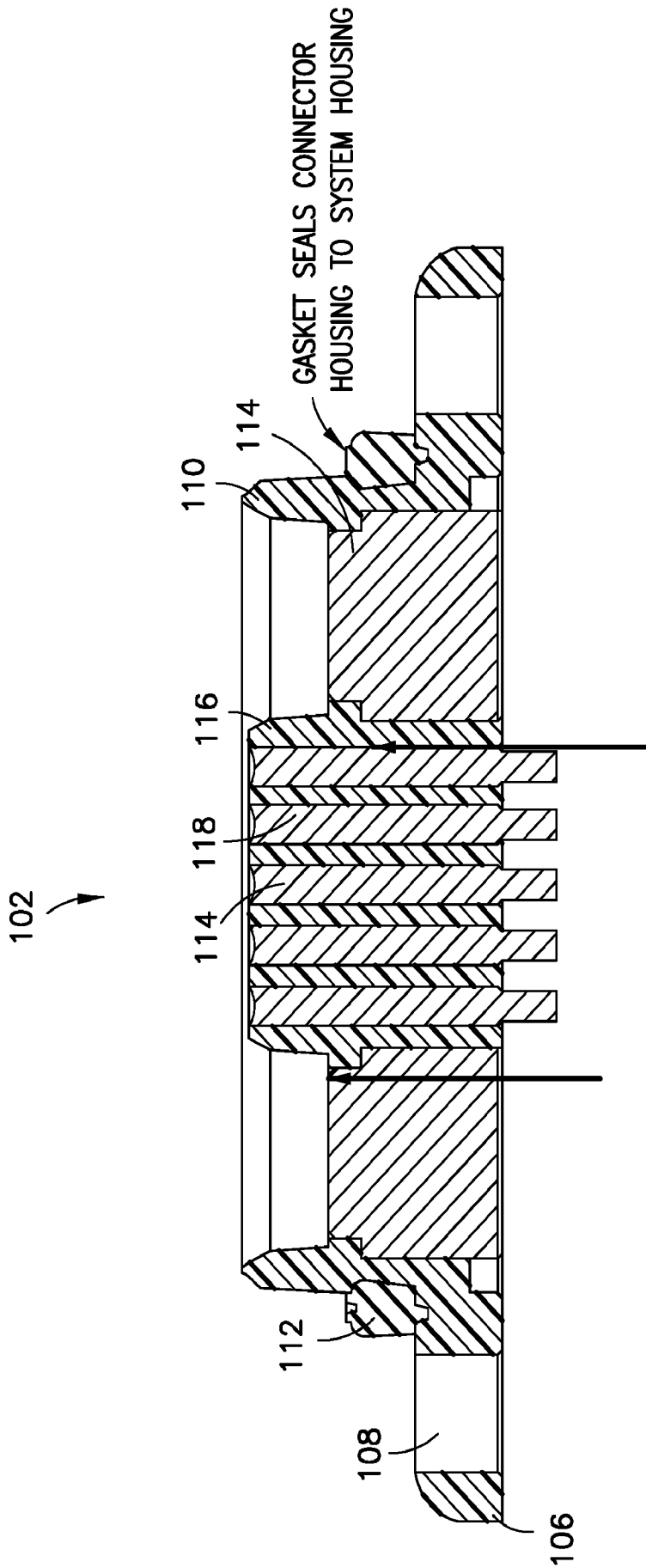

FIG.3

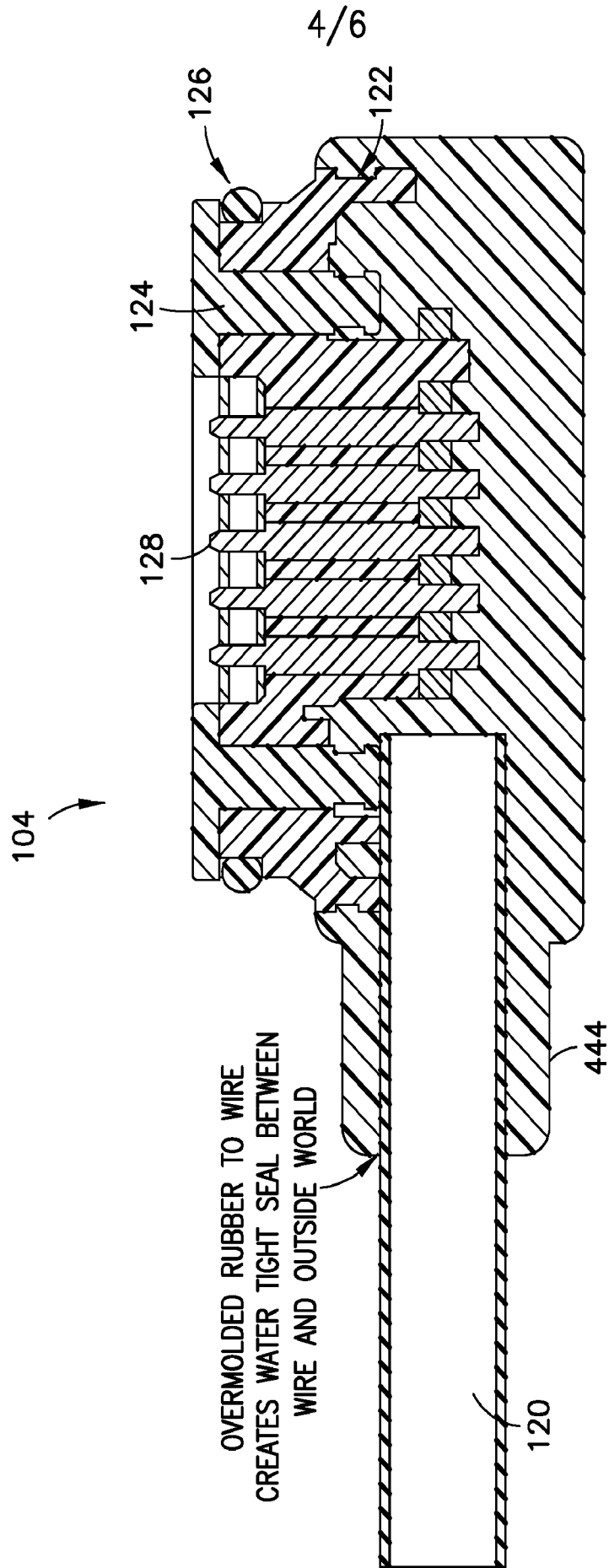

FIG.4

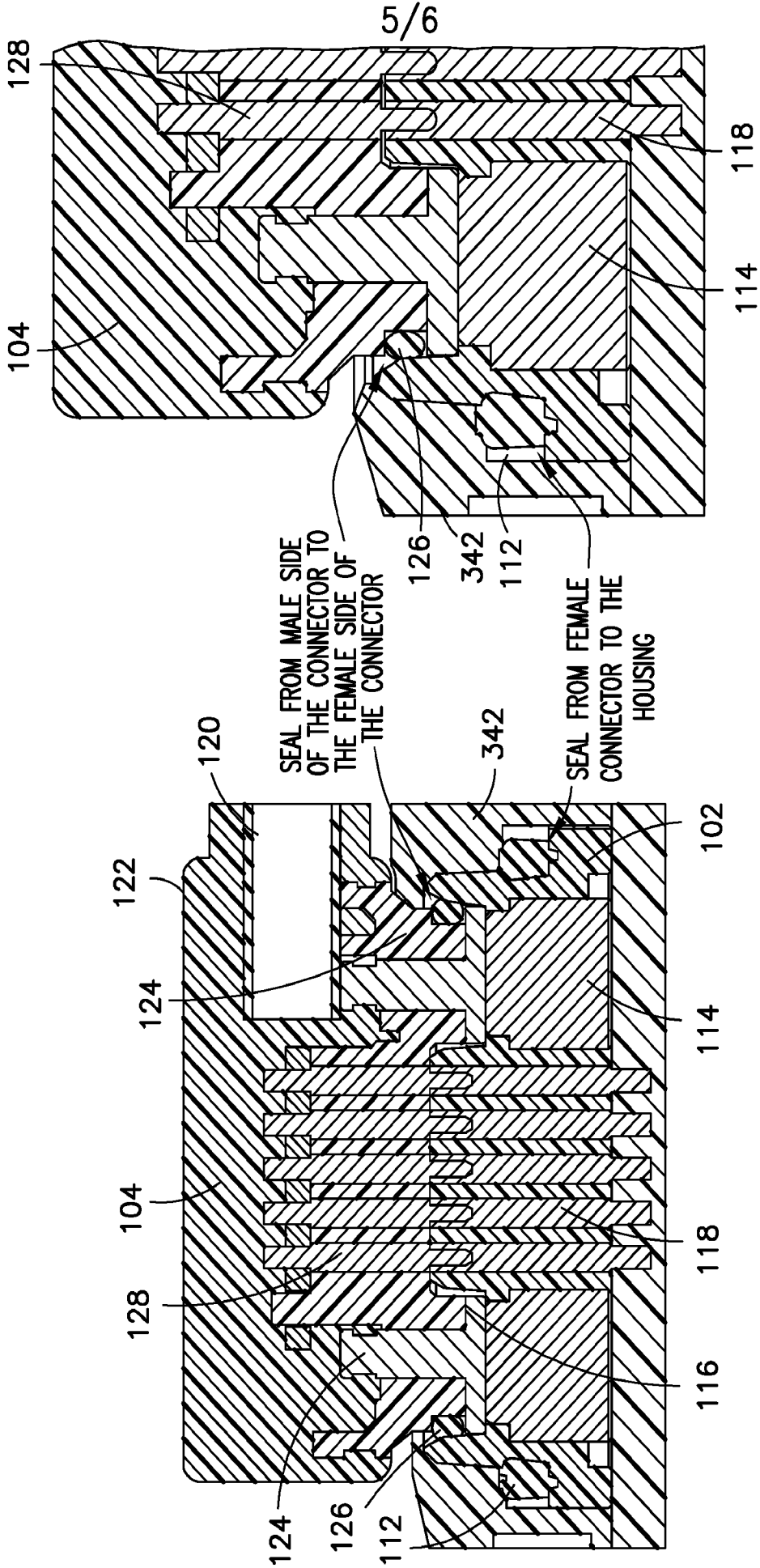

FIG. 5A

FIG. 5B

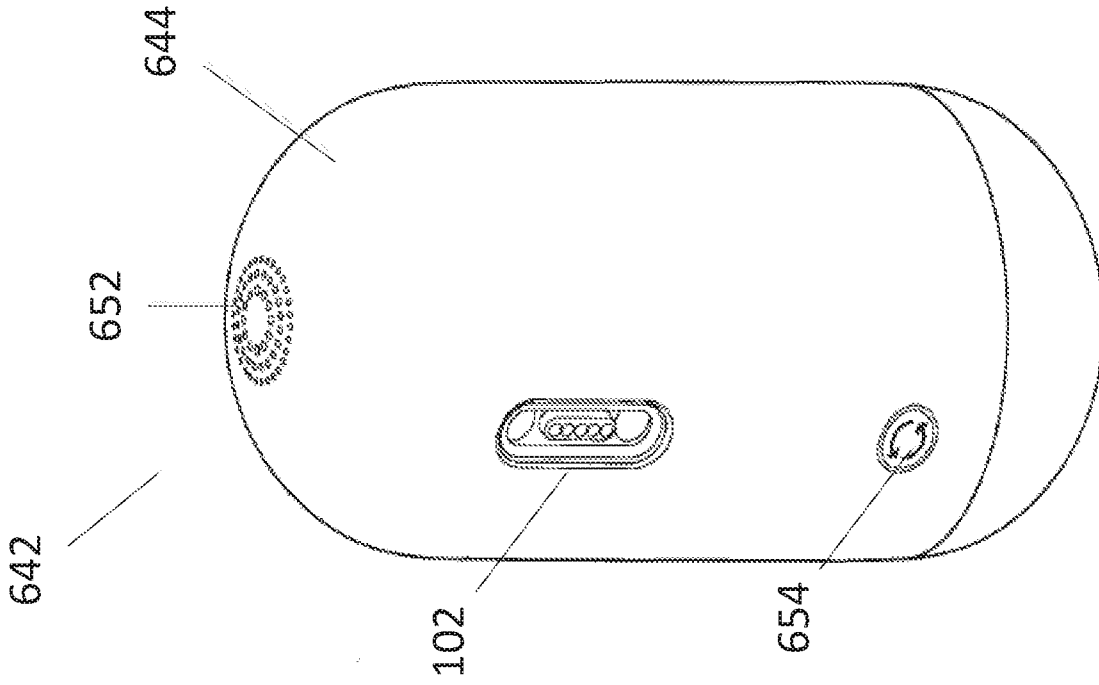

FIG. 6B

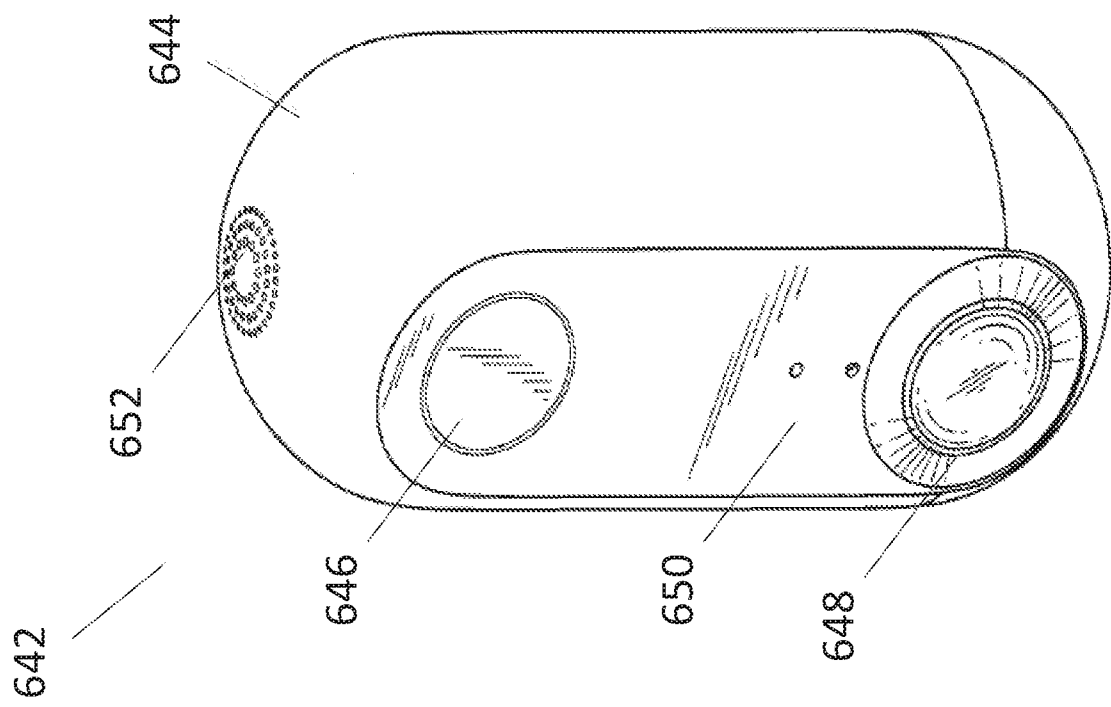

FIG. 6A

## INTERNATIONAL SEARCH REPORT

International application No.

PCT/US 2017/042046

A. CLASSIFICATION OF SUBJECT MATTER		
<i>H01R 25/00 (2006.01)</i> <i>H01R 13/66 (2006.01)</i>		
According to International Patent Classification (IPC) or to both national classification and IPC		
B. FIELDS SEARCHED		
Minimum documentation searched (classification system followed by classification symbols)		
G01R 31/00, 31/02, 31/04, H01R 11/00, 11/11, 11/30, 13/00, 13/02, 13/46, 13/52, 13/62, 13/66, 13/70, 13/703, 13/707, 13/71, 25/00, G02B 6/00, 6/24, 6/36		
Documentation searched other than minimum documentation to the extent that such documents are included in the fields searched		
Electronic data base consulted during the international search (name of data base and, where practicable, search terms used)		
PatSearch (RUPTO internal), USPTO, PAJ, Esp@cenet, Information Retrieval System of FIPS		
C. DOCUMENTS CONSIDERED TO BE RELEVANT		
Category*	Citation of document, with indication, where appropriate, of the relevant passages	Relevant to claim No.
X Y	US 2009/0267613 A1 (APPLE INC.) 29.10.2009, fig. 6, paragraphs [0009], [0031],[0047], [0052]-[0055]	1-9 10-15
Y	US 2012/0148195 A1 (MICROSOFT CORPORATION) 14.06.2012, fig. 1, paragraphs [0017], [0019]-[0021]	10-14
Y	US 2016/0111811 A1 (OTTER PRODUCTS, LLC) 21.04.2016, fig. 1,3, paragraphs [0034], [0040]	15
<input type="checkbox"/> Further documents are listed in the continuation of Box C. <input type="checkbox"/> See patent family annex.		
* Special categories of cited documents:		
“A”	document defining the general state of the art which is not considered to be of particular relevance	“T” later document published after the international filing date or priority date and not in conflict with the application but cited to understand the principle or theory underlying the invention
“E”	earlier document but published on or after the international filing date	“X” document of particular relevance; the claimed invention cannot be considered novel or cannot be considered to involve an inventive step when the document is taken alone
“L”	document which may throw doubts on priority claim(s) or which is cited to establish the publication date of another citation or other special reason (as specified)	“Y” document of particular relevance; the claimed invention cannot be considered to involve an inventive step when the document is combined with one or more other such documents, such combination being obvious to a person skilled in the art
“O”	document referring to an oral disclosure, use, exhibition or other means	“&” document member of the same patent family
“P”	document published prior to the international filing date but later than the priority date claimed	
Date of the actual completion of the international search		Date of mailing of the international search report
25 September 2017 (25.09.2017)		05 October 2017 (05.10.2017)
Name and mailing address of the ISA/RU: Federal Institute of Industrial Property, Berezhkovskaya nab., 30-1, Moscow, G-59, GSP-3, Russia, 125993 Facsimile No: (8-495) 531-63-18, (8-499) 243-33-37		Authorized officer  O. Tsykanovskaya  Telephone No. (495) 531-64-81