

H. G. FISKE.

Machine for Making Sheet Iron Moldings.

No. 106,803.

Patented Aug. 30, 1870.

Fig. 1.

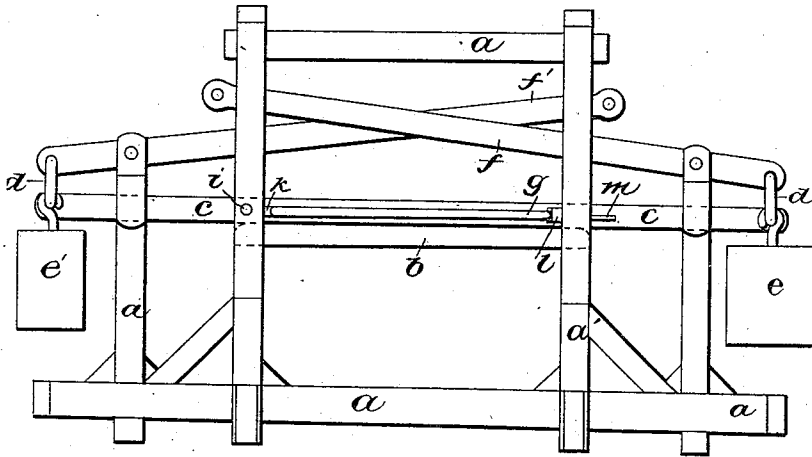
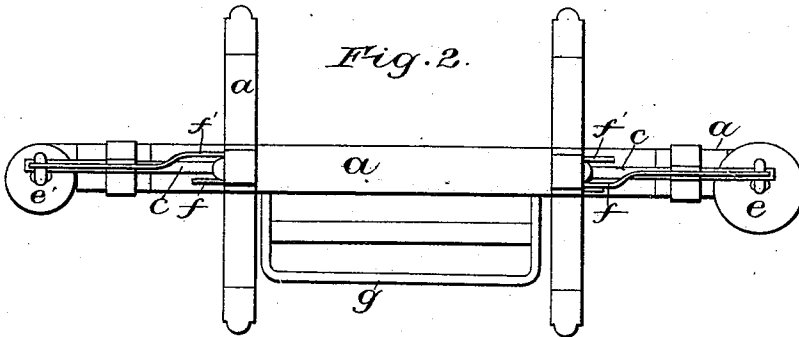

Fig. 2.



Witnesses:

W. D. Garland
David A. Smith

Inventor:

Henry G. Fiske
By C. W. Smith
his Atty.

H. G. FISKE.

Machine for Making Sheet Iron Moldings.

No. 106,803.

Patented Aug. 30, 1870.

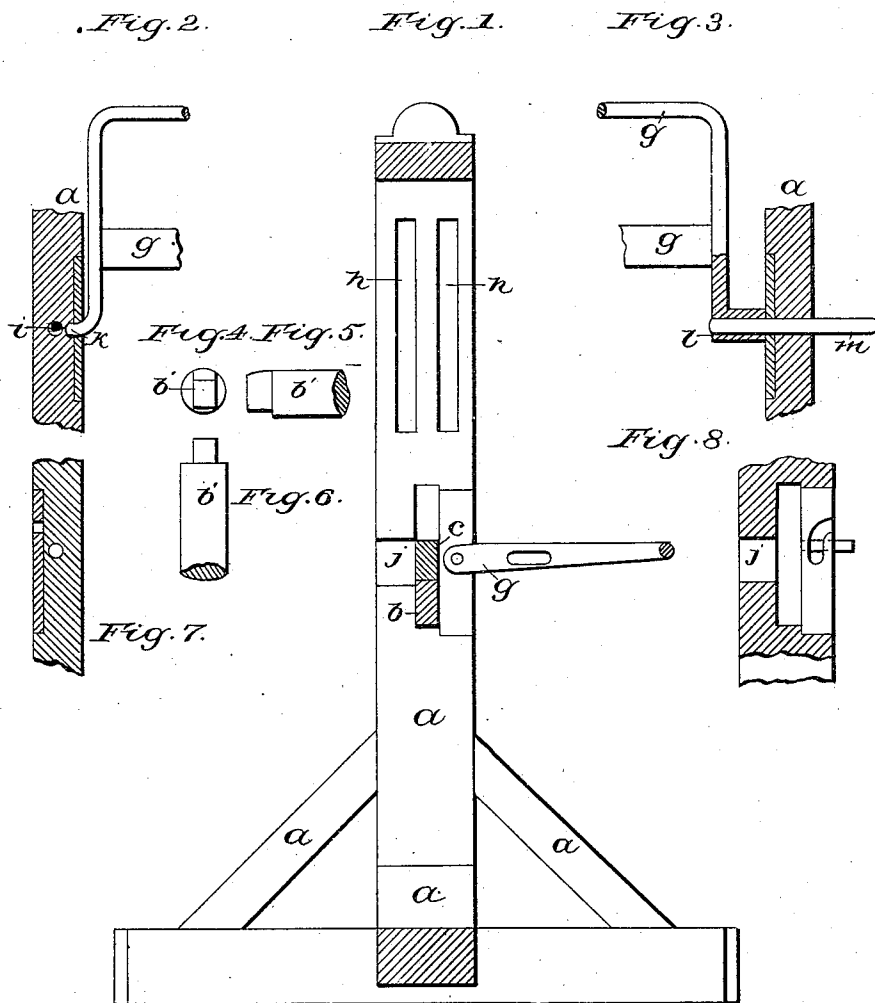

Witnesses:

Wm D Garland
David B Smith

Inventor:

Henry G Fiske
By Wm Smith
his Atty

United States Patent Office.

HENRY G. FISKE, OF SAN FRANCISCO, CALIFORNIA.

Letters Patent No. 106,803, dated August 30, 1870.

IMPROVEMENT IN MACHINE FOR FORMING SHEET-METAL MOLDINGS.

The Schedule referred to in these Letters Patent and making part of the same

To all whom it may concern:

Be it known that I, HENRY G. FISKE, of the city and county of San Francisco, State of California, have invented an Improved Machine for Forming "Sheet-iron Moldings;" and I do hereby declare that the following is a full, clear, and exact description of the same, reference being had to the accompanying drawings and to the letters marked thereon.

My invention relates to a device for holding and bending sheet-iron, and forming it into moldings for architectural purposes, by which the operation is greatly facilitated, and consists of certain details of construction hereinafter set forth.

In the drawing—

Figure 1, sheet 1, is a front elevation of my invention.

Figure 2, sheet 1, a plan of same.

Figure 1, sheet 2, is a transverse vertical section of the same, with certain parts removed.

Figures 2, 3, 4, 5, and 6, sheet 2, are details.

Figures 7 and 8, a device not actually forming a part of the machine, but having relation to it, as hereinafter described.

Like letters refer to like parts.

To enable others skilled in the art or science to which it most nearly appertains to make and use my invention, I will proceed to fully describe its construction and operation.

a represents a frame, consisting of certain sills, posts, and braces, as shown.

b is a rectangular iron bar, resting in mortises in the inner posts.

c, a strong rectangular bar resting upon the bar *b*, and extending through mortises in all the posts, perforated at each end, and provided with open links or double hooks, *d d*, to which the weights *e e* and the levers *f f* are attached.

g is a purchase-frame, hinged to the inner posts in front of the bars *b* and *c*.

The levers *f f* pass through and are guided by mortises *h*, in the inner posts, and have their fulcrum on the top of the outer posts, as shown.

The operation is as follows:

The operator, being in front of the machine, first grasps the long arm of the lever *f* in his hand, and, bringing it down, causes the weight *e* to rise, and with it the corresponding end of the bar *c*, and, consequently, causes the weight *e'* to descend, and with it the other end of the bar *c*, and, the bar being thus caused to roll or tilt over the rounded end of the bar *b*, an open space is thus formed between the two bars, widest at that end of the bar *b* nearest the weight *e*, and terminating in nothing at the point of contact of the two bars. Into this space the operator proceeds to insert the sheet of iron, that has been previously

marked on the upper side, to show the line upon which it is to be bent, by first resting the sheet on the lower bar, then moving it along toward the point of contact of the two bars, until the left-hand edge of the sheet becomes pinched at the proper point, and then swinging the sheet horizontally around that point, as a center, until the whole line coincides with the forward edge or face of the bar, and then, by releasing the lever *f*, the bar *c* will resume a horizontal position, resting entirely upon the sheet of iron, and thus, with the bar *b*, forming a clamp that securely holds the sheet for the operation of bending, which can be readily performed by hand if the iron is light. But, if the material is thick and strong, the aid of the purchase-frame *g* becomes necessary, and which, if forced downward from the position shown in the drawing, will, in its revolution, carry the projecting part of the sheet with it, causing it to bend in the required manner, after which, by again bringing down the lever *f*, the sheet will be released, and the operation can be repeated.

It will be seen that, in the operation already described, the clamping force is equal to the combined weight of the bar *c* and the two weights *e e'*; but only that part of the weight *e* that is unbalanced by the weight *e'* requires power to raise it by the lever *f*. Also, that the same operation could be performed with the same facility and result if the lever *f* was removed, and a pin, *i*, to prevent end motion, inserted in the hole *i*, fitting loosely, in a hole provided for that purpose, in the bar *c*; or an effective clamp is also secured by inserting a closely-fitting pin, *i*, in the same hole *i*, and removing the weight *e'* altogether; but in that case the entire gravity of the weight *e* must be overcome by the operator through the lever *f*, and in that case, also, the upper surface of the bar *b*, or any bar replacing it, of any other form, must have its upper surface always at the same height, or adjustable to that height by pieces provided for that purpose, placed under the ends of those bars. But the complete machine, as shown in sheet 1, adjusts itself to any inequality in the depth or height of the bar used.

A large number of cylindrical or other shaped formers or bars, *b'*, of different sizes and diameters, may be used for this purpose, to enable the operator to produce the different curves required in moldings.

Figs. 4, 5, and 6, sheet 2, show the manner of forming the ends to fit the mortises in the posts, but, on account of the shoulders produced on each end of those cylindrical bars, they are made shorter than the bar *b*, and are passed into position through passages *j* cut in the posts for that purpose. One of these passages is shown in fig. 1, sheet 2. In order to change and insert these bars, both the levers *f f'* are

brought down simultaneously, and the bar *c* and weights *e e'* are thus all raised together, without tilting the bar *c* to a sufficient height to allow of changing the lower bars.

When only thin or light material is being operated upon, it is desirable to remove the purchase-frame to get it out of the way, and, consequently, it is essential that it shall be so constructed that it can be removed or replaced with facility.

Figs. 2 and 3, sheet 2, are sectional views of the two inner posts and purchase-frame, from an examination of which it will be evident that, by means of the journal or end *K*, and the hollow wrist *l*, and the pin *m*, this operation can be very easily effected.

Two views are also given, figs. 7 and 8, in which it is shown how the operation can be effected when both journals of the purchase-frame are formed like the journal *K* in fig. 2.

By this construction it is evident that the axis about which the purchase-frame turns may be made to coincide with the axis of the bar *b'*, if required, but as it is not necessary that it should, it is, for various manifest reasons, more convenient to locate that axis at or near the position shown in the drawing.

In the use of this machine, great economy of labor

and time is had, and a consequent reduction in the price of the moldings produced.

Having thus described my invention,

What I claim, and desire to secure by Letters Patent, is—

1. The bar *c*, in combination with the bars *b b'*, the weights *e*, lever *f*, and pin *i*, with or without the purchase-frame *g*, substantially as and for the purpose described.

2. The bar *c*, in combination with the bars *b b'*, the weights *e e'*, and the lever *f*, with or without the pin *i*, and with or without the purchase-frame *g*, substantially as and for the purpose set forth.

3. The frame *a*, the bar *c*, with the bars *b b'*, the weights *e e'*, the levers *f f'*, the open links *d*, with or without the pin *i*, and with or without the purchase-frame *g*, the whole constructed and arranged to operate substantially as described.

In testimony whereof I have hereunto set my hand and seal.

HENRY G. FISKE. [L. s.]

Witnesses:

O. W. M. SMITH,
H. S. TIBBEY.