



⑫ **EUROPEAN PATENT SPECIFICATION**

④⑤ Date of publication of patent specification :
25.11.92 Bulletin 92/48

⑤① Int. Cl.⁵ : **E01F 9/04**

②① Application number : **90302123.6**

②② Date of filing : **28.02.90**

⑤④ **High-brightness all-weather type pavement marking sheet material.**

③⑩ Priority : **01.03.89 JP 49363/89**

⑦③ Proprietor : **Atom Chemical Paint Co., Ltd.**
9-2, Funado 3-chome, Itabashi-ku
Tokyo 174 (JP)

④③ Date of publication of application :
05.09.90 Bulletin 90/36

⑦② Inventor : **Kobayashi, Sadao**
2-1314, Inage-cho
Chiba-shi, Chiba-ken (JP)
Inventor : **Ijichi, Kouichi**
53, Yoneyama Minami-cho
Sano-shi, Tochigi-ken (JP)
Inventor : **Ishihara, Yuji**
1869-16, Inubushi Kami-cho
Sano-shi, Tochigi-ken (JP)

④⑤ Publication of the grant of the patent :
25.11.92 Bulletin 92/48

⑧④ Designated Contracting States :
AT BE CH DE ES FR GB IT LI LU NL SE

⑦④ Representative : **Votier, Sidney David et al**
CARPMAELS & RANSFORD 43, Bloomsbury
Square
London WC1A 2RA (GB)

⑤⑥ References cited :
EP-A- 0 237 315
EP-A- 0 299 744
EP-A- 0 304 405
CH-A- 665 665
DE-A- 3 022 300
FR-A- 1 049 818
FR-A- 2 558 185
GB-A- 2 165 773

EP 0 385 746 B1

Note : Within nine months from the publication of the mention of the grant of the European patent, any person may give notice to the European Patent Office of opposition to the European patent granted. Notice of opposition shall be filed in a written reasoned statement. It shall not be deemed to have been filed until the opposition fee has been paid (Art. 99(1) European patent convention).

Description

This invention relates to a pavement marking sheet material and, more particularly, to an all-weather type pavement marking sheet material having a high brightness in reflection against light incident at a large angle of incidence and even during night when it is raining.

There are various prior art pavement marking sheet materials having a light reflex-reflecting function which are used for pavement marking purposes such as providing marking lines and road marks on the roads. Pavement marking sheet material which are presently used for pavement marking purposes all have glass microspheres as reflex-reflecting element dispersed on the surface thereof or mixed in the material for affording visibility during night. These pavement marking sheet materials have the common disadvantage that, when the surface of the marking material is covered with a film of water when it is raining, upper hemisphere portions of the glass microspheres exposed in air above the surface of the marking material and performing a light reflecting function are mostly submerged in the film of water with a result that the light reflecting function is impaired and visibility during night when it is raining becomes extremely poor.

For improving visibility of the pavement marking sheet materials during night when it is raining, some proposals have been made in the past. For example, some publications such as U.S. Patent No. 4,388,359 intend to improve the visibility during night when it is raining by providing a multitude of projections and depressions on the surface of a sheet material in which glass microspheres are embedded. For another example, Japanese Patent Application Laid-open No. 211403/1987 discloses forming, at intervals in the longitudinal direction of the base sheet or continuously in the longitudinal direction of the base sheet in a part of the base sheet as viewed in the transverse direction of the base sheet, of an area in which glass microspheres having refractive index of 2.0 - 2.4 which relatively do not lose the light reflecting function during night when it is raining are embedded in the base sheet.

These prior art all-weather type pavement marking sheet materials have the expected visibility when light from head lamps of vehicles running during night is incident at a relatively small angle of incidence with respect to the pavement marking sheet materials. Light from head lamps of a vehicle, however, is usually incident at a very large angle of incidence of 60 - 80 degrees with respect to the pavement marking sheet materials and, at such large angle of incidence, brightness in reflection of the pavement marking sheet materials is reduced. The brightness in reflection is reduced particularly when it is raining due to a film of water covering the pavement marking sheet materials. Reduction in the brightness in reflection of a pavement marking sheet material during night when it is raining is very dangerous and it has therefore been desired to improve the brightness in reflection of a pavement marking sheet material against light which is incident at such a large angle of incidence.

FR-A-1049818 describes a high-brightness all-weather type pavement marking sheet material comprising: a reflex-reflecting sheet comprising a layer of glass microspheres which are at least partially exposed in air and bonded to one another by a transparent resin and a reflecting layer consisting of a metallized film provided behind the transparent resin layer; and a base sheet bonded to the lower surface of the reflex-reflecting sheet.

CH-A-665665 describes a pavement marking glass material in which partially exposed relatively large glass microspheres together with relatively small microspheres are embedded in a single transparent layer.

It is, therefore, an object of the invention to provide an all-weather type pavement marking sheet material having a sufficient brightness in reflection against light which is incident at an incident angle of 60 degrees or over at which a pavement marking sheet material is usually used and also having a high brightness in reflection during night when it is raining.

Accordingly, the invention provides a high-brightness all-weather type pavement marking sheet material comprising a reflex-reflecting sheet comprising a layer of glass microspheres of a relatively large diameter which are at least partially exposed in air and bonded to one another by a transparent resin, a reflecting layer consisting of a metallized film provided behind said transparent resin layer and a base sheet bonded to the lower surface of the reflex-reflecting sheet, characterized in that a layer of glass microspheres of a relatively small diameter are buried and fixed in a transparent resin layer between the layer of glass microspheres of a relatively large diameter and the reflecting layer, there being an interval between the glass microspheres of a large diameter and the glass microspheres of a small diameter and in that the base sheet is made of rubber of synthetic resin.

According to the invention, light incident at a large angle of incidence of 60 degrees or over is incident upon the glass microspheres of a relatively small diameter in the reflex-reflecting sheet through the glass microspheres of a relatively large diameter and the transparent resin, is reflected by the reflecting layer and is reflex-reflected passing through the glass microspheres of a relatively small diameter, the transparent resin and the glass microspheres of a relatively large diameter. Accordingly, by suitably selecting and combining the refractive indexes of the glass microspheres of a relatively large diameter, the glass microspheres of a relatively small

diameter and the transparent resin, the diameters of the glass microspheres of a relatively large diameter and the glass microspheres of a relatively small diameter, and the interval between the glass microspheres of a relatively large diameter and the glass microspheres of a relatively small diameter, a sufficiently high reflex-reflecting characteristic can be obtained at an angle of incidence of 60 degrees or over.

5 Moreover, it has been found that, by adopting the above described structure according to the invention, the brightness in reflection is not substantially reduced but is rather increased compared with a dry state (i.e., a state corresponding to night when it is fine) even when the exposed portions of the glass microspheres of a relatively large diameter are covered with a film of water.

10 Since the glass microspheres of a relatively large diameter are at least partially exposed in air, the amount of light received by the glass microspheres is large even if the angle of incidence is large so that a relatively large amount of light reaches the reflecting layer provided at a lower layer.

Since the base sheet made of unvulcanized rubber, for example, is provided behind the reflex-reflecting sheet, shock applied on the glass microspheres provided on the surface by a passing vehicle is mitigated and the likelihood of coming off of these glass microspheres is reduced.

15 The invention will be described more fully below with reference to the accompanying drawings.

In the accompanying drawings,

Fig. 1 is a sectional view of the high-brightness all-weather type pavement marking sheet material according to the invention;

20 Fig. 2 is an enlarged sectional view of a lower layer section of the reflex-reflecting sheet in the pavement marking sheet material;

Fig. 3 is a graph showing brightness in reflection of an embodiment of the invention in comparison with that of a prior art pavement marking sheet material; and

Fig. 4 is a graph showing relationship between the thickness of the focus adjusting resin layer and the brightness in reflection according to the invention.

25 Referring first to Fig. 1, resin 3 of a reflex-reflecting sheet 1 is required to have transparency and have a sufficient strength to hold glass microspheres 4 of a relatively large diameter. Further, since the pavement marking sheet material is used on the road, the resin 3 must be selected taking account of resistances to wear, staining and color change. As resins satisfying these requirements, acrylic polymers, aliphatic urethanes and cross-linked polyester are preferably used. Thermoplastic resins such as vinyl polymers and cellulose acetate butylate may also be used.

30 Since the pavement marking sheet material of the invention is so constructed that the glass microspheres 4 of a relatively large diameter are at least partially exposed in air to receive a large amount of light even if light is incident at a large angle of incidence so that the reflecting layer provided as a lower layer can receive a large amount of light, the larger the diameter of the glass microspheres 4, the greater is this effect for reflecting light incident at a large angle of incidence. However, in view of the fact that the glass microspheres 4 are used on the road, use of glass microspheres of a diameter exceeding 2mm is problematical since they will come off easily. If, on the other hand, the diameter of the glass microspheres is less than 0.25 mm, the brightness in reflection is insufficient for achieving the object of the invention. It is therefore necessary to select glass microspheres of a diameter within the range of 0.25 mm - 2 mm as the glass microspheres 4. Glass microspheres of a diameter of 0.25 mm - 0.5 mm are found particularly preferable.

35 As the glass microspheres 4, glass microspheres of a refractive index within a range of 1.75 - 2.2 are preferable. If the refractive index is less than 1.75, a sufficient brightness in reflection cannot be attained whereas if the refractive index exceeds 2.2, it is difficult to manufacture such glass microspheres so that the cost of manufacture becomes extremely high.

45 The glass microspheres 4 of a relatively large diameter are dispersed substantially uniformly over the resin so that they will cover about 30 - 60% of the entire surface area of the reflex-reflecting sheet 1 and the glass microspheres 4 form a layer.

In the reflex-reflecting sheet 1, glass microspheres 5 of a relatively small diameter are buried and fixed in a transparent resin layer behind the glass microspheres 4 of a relatively large diameter with an interval between the glass microspheres 4 and the glass microspheres 5 form a layer. In the rear portion of a transparent resin layer behind the glass microspheres 5 of a relatively small diameter is provided a reflecting layer 8 consisting of a metallized film or the like material. As the glass microspheres 5 of a relatively small diameter, glass microspheres of a diameter within a range of 53 μ m - 63 μ m and a refractive index within a range of 2.0 - 2.2 are preferable. The reflecting layer 8 can be formed by forming a metallized film such as an aluminum film by a known method such as a vacuum deposition in the rear portion of a focus adjusting resin layer 7 provided behind the glass microspheres 5 and performing a function of adjusting the position of the reflecting layer 8 so that it coincides with the focus of the glass microspheres 5.

Further description will be made about an example in which a lower layer portion is shown in the enlarged

sectional view in Fig. 2 is produced first and then an upper layer portion b is provided on the lower layer portion a.

The lower layer portion a comprises a glass microsphere holding resin layer 6 holding the glass microspheres 5, a focus adjusting resin layer 7 adjusting the thickness of the film of resin in accordance with the focus of the glass microspheres 5 and a reflecting layer 8 made of a metallized film or the like material and having curved surfaces concentric with the glass microspheres 5. If necessary, the lower layer portion a may comprise further a surface resin layer 9 for reinforcing the glass microsphere holding resin layer 6. Reference numeral 10 denotes an adhesive layer made of acrylic resin or the like adhesive material. The glass microspheres 5 are embedded in about 20% - 30% of their diameter in the glass microsphere holding resin layer 6. In case the surface resin layer 9 is provided, thickness of about 10 μm - 30 μm is sufficient as the thickness of this layer 9.

The upper layer portion b comprises a transparent resin layer 3 formed on the lower layer portion a by suitable means such as coating and this transparent resin layer 3 holds the glass microspheres 4 of a relatively large diameter. As the thickness of this transparent resin layer 3 for fixing the glass microspheres 4, a minimum thickness of 20 μm will be sufficient. In view of the necessity for holding the glass microspheres 4 on the roads, however, a thickness of at least 70 μm will be necessary. The film thickness of the resin layer 3 has correlation with the diameter of the glass microspheres 4 and a preferable film thickness is half or less of the diameter of the glass microspheres 4. The film thickness of the resin layer 3 therefore can be within a range of 20 μm - 100 μm and preferably 70 μm - 100 μm . If the film thickness is less than 20 μm , the strength of the resin layer 3 for holding the glass microspheres 4 is insufficient whereas if the film thickness exceeds 100 μm , the brightness in reflection is reduced.

The method for manufacturing the reflex-reflecting sheet 1 is of course not limited to the above described one but the reflex-reflecting sheet 1 may be manufactured by other method such as making it in sequence from the side of the glass microspheres 4 of a relatively large diameter.

A base sheet 2 bonded at the back of the reflex-reflecting sheet 1 requires to be made of a material having excellent conformability to the irregular pavement surface and durability to various mechanical forces. The base sheet 2 therefore comprises, as its main ingredient, unvulcanized synthetic rubber such, for example, as acrylonitrile-butadiene rubber (NBR), isobutylene-isoprene rubber (IIR), chloroprene rubber (CR), chlorosulphonyl-polyethylene, a urethane rubber or a synthetic resin such, for example, as polyvinyl chloride. The base sheet 2 may comprise, if necessary, additives including a filler such as calcium carbonate powder and a pigment for providing color to the base sheet. The mixture of these ingredients is formed into a sheet with a thickness of 5 mm or less by passing it through pressure rolls or by other convenient methods.

An adhesive layer 11 of a suitable thickness of 50 μm or more, preferably about 100 μm - 200 μm , is provided under the lower surface of the base sheet 2. A release paper 12 is normally attached to the lower surface of the adhesive of the adhesive layer 11 but it may be omitted depending upon the type of the adhesive employed in the adhesive layer 11.

For making the base sheet, the unvulcanized synthetic rubber or synthetic resin which is an ingredient of the base sheet 2 is added with desired amount of the filler, pigment and other materials if required. The mixture is blended and is formed into a sheet of a thickness of 5 mm or less through heated pressure rolls and then is wound into a roll. If necessary, the roll of the base sheet is unwound and an adhesive coated on a release paper in a thickness of 50 μm or more is superposed on the lower surface of the base sheet and then the base sheet is wound again.

The base sheet 2 may be composed of two layers, i.e., a base layer made of the above described ingredients and a thin colored layer provided on the base layer. In this two layered structure, the thickness of the base layer preferably is about 1.0 mm - 1.6 mm and the thickness of the colored layer on the base layer preferably is about 20 - 25 μm . The thickness of the thin colored layer on the base layer is required to have the same features as those of the base layer described above, to be adhered integrally to the base layer and to be colored in a desired color for the pavement marking purpose so that the same material as, or a material which is different but has the same properties as, the unvulcanized synthetic rubber used for the base layer added with a suitable coloring agent is preferably employed.

For forming the colored layer on the base layer, the base layer which has once been wound into a roll is unwound and the colored layer is formed thereon by coating a liquidized material prepared by dissolving an unvulcanized synthetic rubber material in a solvent and adding a coloring agent affording a desired color there to on the upper surface of the base layer by an amount sufficient for giving a desired thickness to the coated film after drying.

The base sheet 2 may be a double layer structure composed of an upper layer of a relatively hard material having excellent durability to various mechanical forces and a lower layer of a relatively soft material having an excellent conformability to an irregular pavement surface. If the lower layer is made of a material having

JIS K6301 hardness of 30° - 75° and restoration rate of 50% or less, the base sheet 2 has an excellent conformability to the pavement surface and is hardly separated once it has been adhered to the pavement surface.

In the case of making the base sheet 2 in such double layer structure, the above described hardness and restoration rate can be obtained by, for example, adding a relatively large amount of plastic material in the ingredients of the lower layer. The amount of addition of such plastic material required in the ingredients of the lower layer is 2 parts by weight or more. Suitable plastic materials for this purpose include elastomer, plasticizers (D.O.P. chlorinated paraffin, epoxy etc.) and liquid rubber. The two layers comprise, as their main ingredients, unvulcanized synthetic rubber such, for example, as acrylonitrile-butadiene rubber (NBR), isobutylene-isoprene rubber (IIR) and chloroprene rubber (CR) or a synthetic resin such, for example, as chlorosulphonyl-polyethylene, chlorinated polyethylene and polyvinyl chloride or other material known in the field of the pavement marking sheet material. The two layers may comprise, if necessary, additives including a filler such as calcium carbonate powder and a pigment for providing color to these layers. The mixture of these ingredients is formed into a sheet with a thickness of 2 mm or less by passing it through pressure rolls or by other conventional methods. An adhesive layer of a suitable thickness of a 50 μm or more, preferably 100 μm - 200 μm, is provided under the lower surface of the lower layer. The adhesive layer can be formed by coating adhesive on a release paper in a desired thickness and superposing it on the lower surface of the lower layer.

For making the base sheet 2 of this double layer structure, the unvulcanized synthetic rubber or synthetic resin which is an ingredient of the upper layer and the lower layer is added with desired amounts of the filler, pigment and other materials if required. A desired amount of plastic materials is further added to the material for forming the lower layer. The respective mixtures are blended and are formed into sheets of a thickness of 2 mm or less through heated pressure rolls and the sheets constitute the upper layer and the lower layer. If necessary, an adhesive coated on a release paper in a thickness of 50 μm or more is superposed on the lower surface of the lower layer.

After preparing the upper layer and the lower layer in the foregoing manner, the upper layer and the lower layer are adhered to each other by either coating adhesive on the upper surface of the lower layer or softening the upper surface portion of the lower layer by heating and thereafter superposing the upper layer on the lower layer. Alternatively, a previously formed upper layer may be superposed upon a lower layer which has just been extruded from an extrusion sheet forming device and thereupon the two layers may be bonded together by applying pressure by pressure rolls.

Instead of making the upper layer and the lower layer as separate sheets and superposing one upon the other and bonding them together, the upper layer and the lower layer may be formed as a single base sheet from the beginning by employing the same ingredients as the lower layer and the upper layer may be formed by irradiating electron beam on the upper half portion of the single base sheet and thereby hardening the upper half portion whereas the lower half portion of the base sheet which is not irradiated with electron beam may constitute the lower layer.

The pavement marking sheet material according to the invention may be obtained by, for example, laminating, under heat and pressure, the reflex-reflecting sheet 1 made in the above described manner with the base sheet 2 which is separately made in the above described manner.

An example of the pavement marking sheet material according to the invention will be described below.

(1) Forming of the lower layer portion a of the reflex-reflecting sheet 1

As the resin constituting the surface resin layer 9, a resin which is a mixture of 100 parts of a modified acrylic resin and 10 parts of melamine resin or isocyanate as a crosslinker was coated on a carrier film (polyester film) with a thickness of 10 μm - 30 μm and was dried and cured to form the surface resin layer 9.

Then, as the resin constituting the glass microsphere holding layer 6, a resin which is a mixture of 100 parts of a modified acrylic resin and 15 parts of a crosslinker is coated on the surface resin layer 9 with a thickness of 10 μm - 40 μm. In a half-cured state, glass microspheres 5 having a diameter within the range of 53 μm - 63 μm and a refractive index of 2.2 were uniformly dispersed over the resin and the resin was dried and cured to fix the glass microspheres 5 and form the glass microsphere holding layer 6.

Nextly, as the resin constituting the focus adjusting resin layer 7, a resin obtained by dissolving a mixture of 100 parts of a modified acrylic resin and 5 - 10 parts of a crosslinker in a solvent which is a mixture of MIBK and toluene is coated on the side of the glass microspheres 5 of the glass microsphere holding layer 6 in a coating amount of 30g/m² as state after volatilizing the solvent and was dried and cured to form the focus adjusting resin layer 7.

The reflecting layer 8 was formed by depositing an aluminum reflecting film on the exposed surface of the focus adjusting resin layer 7 by the vacuum deposition method. An acrylic adhesive was coated on a release paper and laminated on the aluminum deposited surface and thereafter the carrier film on the surface resin

layer 9 was removed to complete the lower layer portion a of the reflex-reflecting sheet 1. The refractive index of the resin constituting the lower layer portion a of the reflex-reflecting sheet 1 was 1.52.

(2) Forming of the upper layer portion b of the reflex-reflecting sheet 1

5

As the resin constituting the upper layer portion b on the lower layer portion a of the reflex-reflecting sheet 1, a resin which is a mixture of 100 parts of a modified acrylic resin and 15 parts of a crosslinker was coated on the surface of the lower layer portion a of the reflex-reflecting sheet 1 with a thickness of about 75 μm . In a half dried state, glass microspheres 4 having diameters of 350 μm - 500 μm and refractive index within the range of 1.90 - 1.92 were dispersed uniformly over the resin so that these glass microspheres 4 will occupy 32% of the entire surface of the resin. Then the resin was dried and cured to form the upper layer portion b. The refractive index of the resin constituting the upper layer portion b was 1.52.

10

(3) Forming of the base sheet 2

15

As the base sheet 2, the double layer structure consisting of the upper layer made of a relatively hard material having excellent durability to various mechanical forces and the lower layer made of a relatively soft material having an excellent conformability to the irregular pavement surface was adopted.

For producing the upper layer, 30 parts of NBR, 5 parts of BR, 15 parts of petroleum resin, 30 parts of TiO_2 and 140 parts of CaCO_3 were blended and formed into a sheet having a thickness of 0.7 mm and a width of 1,000 mm through an extrusion process at a processing temperature of 90° C. For producing the lower layer, 30 parts of NBR, 5 parts of BR, 15 parts of petroleum resin, 30 parts of TiO_2 , 140 parts of CaCO_3 , 5 parts of liquid rubber, 7 parts of chlorinated polyethylene and 5 parts of D.O.P. were blended and formed into a sheet having a thickness of 0.7 mm and a width of 1,000 mm through an extrusion process at a processing temperature of 90° C in the same manner as in producing the upper layer.

20

25

An adhesive layer 11 was formed by superposing a release paper coated with a pressure sensitive adhesive to a thickness of 100 μm on the lower surface of the lower layer. Then, a pressure sensitive adhesive was coated on the upper surface of the lower layer and then the upper layer was superposed on the lower layer and the two layers were bonded together. A release paper coated with a pressure sensitive adhesive was superposed on the upper surface of the upper layer whereby the base sheet 2 was completed.

30

(4) Completion of the pavement marking sheet material

The release paper laminated on the lower surface of the reflex-reflecting sheet 1 and the release paper laminated on the upper surface of the upper layer of the base sheet 2 were removed. The reflex-reflecting sheet 1 and the base sheet 2 were laminated to each other on their sides on which the adhesive was coated by pressing them together under heat whereby the high-brightness all-weather type pavement marking sheet material according to the invention was completed.

35

(5) Measurement of the brightness in reflection

40

The brightness in reflection of the pavement marking sheet material of the above described example was measured with respect to each of a dry state and a wet state of the glass microspheres with the angle of incidence being varied between 60° and 80°. For comparison, the brightness in reflection of the pavement marking sheet material of the type described in the above mentioned U.S. Patent No. 4,388,359 (hereinafter referred to as "prior art A") and the pavement marking sheet material of the type described in the above mentioned Japanese Patent Application Laid-open No. 211403/1987 (hereinafter referred to as "prior art B") was measured under the same measuring conditions as the example of the present invention. The brightness in reflection was measured by the brightness measuring method according to JISZ9117. As to the brightness in the state in which the glass microspheres are wet with water, measurement was made in a state in which the product was completely wet by filling a vessel made of an acrylic plate with water and thereafter reduction in the brightness due to the acrylic plate was adjusted. Results of the measurement of the respective pavement marking sheet materials are shown in the following Table 1 and Fig. 3

45

50

55

5

Table 1

Brightness in reflection of respective sheet materials (cd/ft²)

10

15

20

25

Sheet type	Present invention		Prior art A		Prior art B	
Angle of incidence	Dry state	Wet state	Dry state	Wet State	Dry state	Wet state
60°	7.3	9.4	1.00	0.726	1.45	0.967
70°	2.69	3.69	0.622	0.553	0.933	0.726
75°	1.38	1.90	0.484	0.450	0.691	0.587
80°	0.657	0.796	0.380	0.380	0.484	0.450

30

35

40

45

50

55

From the above results of measurement, it will be understood that the pavement marking sheet material according to the invention has a higher brightness in reflection than the prior art products at a large angle of incidence of 60° - 80°. The results of measurement show also that the brightness in reflection of the prior art products is lower when the glass microspheres are wet than when they are dry whereas the brightness in reflection of the pavement marking sheet material according to the present invention is higher when the glass microspheres are wet than when they are dry.

For examining the influence of the film thickness of the focus adjusting resin layer 7 of the reflex-reflecting sheet 1 over the brightness in reflection in the example of the present invention, the brightness in reflection when the amount of coating of the resin constituting the focus adjusting resin layer 7 is varied was measured by employing the same measuring method as was employed in the measurement described above. Results of measurement are shown in the following Table 2 and Fig. 4 in which a specimen in which the coating amount was 23.49 g/m² is designated as Sample A, a specimen in which the coating amount was 29.77 g/m² as Sample B, a specimen in which the coating amount was 35.38 g/m² as Sample C respectively.

5

Table 2

10

Relation between the film thickness of the focus adjusting resin layer and brightness in reflection (cd/fc/ft²)

15

Sheet sample	A (23.49g/m ²)		B (29.77g/m ²)		C (35.38g/m ²)	
Angle of incidence	Dry state	Wet state	Dry state	Wet state	Dry state	Wet state
60°	2.64	3.79	6.05	7.69	4.14	5.56
70°	1.04	1.56	2.09	2.83	1.46	2.02
75°	0.591	0.869	1.01	1.39	0.80	1.08
80°	0.347	0.416	0.489	0.628	0.452	0.521

20

25

30

35

From the above results of measurement, it will be understood that, in the pavement marking sheet material according to the invention, the highest brightness in reflection is obtained in the case where the film thickness of the focus adjusting resin layer 7 is that of the Sample B. The results of measurement show also that, in all of the Samples A, B and C, a higher brightness in reflection can be obtained when the glass microspheres are wet than when they are dry.

40

Claims

45

50

55

1. A high-brightness all-weather type pavement marking sheet material comprising a reflex-reflecting sheet comprising a layer of glass microspheres of a relatively large diameter (4) which are at least partially exposed in air and bonded to one another by a transparent resin (3), a reflecting layer (8) consisting of a metallized film provided behind said transparent resin layer (3) and a base sheet (2) bonded to the lower surface of the reflex-reflecting sheet, characterized in that a layer of glass microspheres of a relatively small diameter (5) are buried and fixed in a transparent resin layer (6, 7, 9) between the layer of glass microspheres of a relatively large diameter (4) and the reflecting layer (8), there being an interval between the glass microspheres of a large diameter and the glass microspheres of a small diameter and in that the base sheet (2) is made of rubber or synthetic resin.
2. A high-brightness all-weather type pavement marking sheet material as defined in claim 1 wherein said glass microspheres of a relatively large diameter have a diameter of 0.25 mm - 2 mm.
3. A high-brightness all-weather type pavement marking sheet material as defined in claim 1 or claim 2 wherein said glass microspheres of a relatively large diameter have refractive index of 1.78 - 2.2.
4. A high-brightness all-weather type pavement marking sheet material as defined in any one of claims 1-3 wherein said transparent resin layer by which said glass microspheres of a relatively large diameter are

bonded together has a film thickness of 20 µm - 100 µm.

Patentansprüche

5

1. Allwettertaugliche Strassenmarkierungsmaterialbahn mit hoher Sichtbarkeit
 - mit einer retroreflektierenden Bahn aus einer Schicht aus Mikrogaskugeln eines relativ großen Durchmessers (4), die wenigstens teilweise an der Luft offen liegen und aneinander durch ein transparentes Harz (3) gebunden sind,
 - 10 - einer reflektierenden Schicht (8) aus einem metallisierten Film, der hinter dieser transparenten Harzschicht (3) sitzt und
 - einer Trägerbahn (2), die an die untere Oberfläche der retroreflektierenden Schicht gebunden ist, dadurch gekennzeichnet, daß eine Schicht aus Mikrogaskugeln eines relativ kleinen Durchmessers (5) in einer transparenten Harzschicht (6, 7, 9) zwischen der Schicht der Mikrogaskugeln eines relativ großen Durchmessers (4) und der reflektierenden Schicht (8) verlegt und fixiert ist, wobei ein Abstand zwischen den Mikrogaskugeln eines großen Durchmessers und den Mikrogaskugeln eines kleinen Durchmessers vorhanden ist und daß die Trägerbahn (2) aus Kautschuk aus synthetischem Harz hergestellt ist.
- 20 2. Allwettertaugliche Strassenmarkierungsmaterialbahn mit hoher Sichtbarkeit wie in Anspruch 1 definiert ist, bei der diese Mikrogaskugeln eines relativ großen Durchmessers einen Durchmesser von 0,25 mm - 2 mm aufweisen.
3. Allwettertaugliche Strassenmarkierungsmaterialbahn mit hoher Sichtbarkeit wie in Anspruch 1 oder Anspruch 2 definiert ist, bei der diese Mikrogaskugeln eines relativ großen Durchmessers einen Brechungsindex von 1,78 - 2,2 aufweisen.
- 25 4. Allwettertaugliche Strassenmarkierungsmaterialbahn mit hoher Sichtbarkeit wie in irgendeinem der Ansprüche 1-3 definiert ist, bei der diese transparente Harzschicht, durch die diese Mikrogaskugeln eines relativ großen Durchmessers miteinander verbunden sind, eine Filmdicke von 20 µm - 100 µm aufweist.

30

Revendications

35

1. Matériau de marquage en feuille à haute brillance pour signalisation routière par tous temps comprenant une feuille rétroreflectrice comprenant une couche de microsphères de verre d'un diamètre relativement grand (4) qui sont au moins partiellement exposées à l'air et liées les unes aux autres par une résine transparente (3), une couche réfléchissante (8) constituée d'un film métallisé disposé derrière la couche de résine transparente (3) précitée et une feuille de base (2) liée à la surface inférieure de la feuille rétroreflectrice, caractérisé en ce qu'une couche de microsphères de verre de diamètre relativement petit (5) est noyée et fixée dans une couche de résine transparente (6, 7, 9) entre la couche de microsphères de verre de diamètre relativement grand (4) et la couche réfléchissante (8), un intervalle subsistant entre les microsphères de verre de grand diamètre et les microsphères de petit diamètre, et en ce que la feuille de base (2) est constituée de caoutchouc de résine synthétique.
- 40 2. Matériau de marquage en feuille de haute brillance pour signalisation routière par tous temps selon la revendication 1, dans lequel les microsphères de verre de diamètre relativement grand précitées ont un diamètre de 0,25 à 2 mm.
3. Matériau de marquage en feuille de haute brillance pour signalisation routière par tous temps selon la revendication 1 ou 2, dans lequel les microsphères de verre de diamètre relativement grand précitées ont un indice de réfraction de 1,78 à 2,2.
- 45 4. Matériau de marquage en feuille de haute brillance pour signalisation routière par tous temps selon l'une quelconque des revendications 1-3, dans lequel la couche de résine transparente précitée qui lie ensemble les microsphères de diamètre relativement grand a une épaisseur de 20 à 100 micromètres.

55

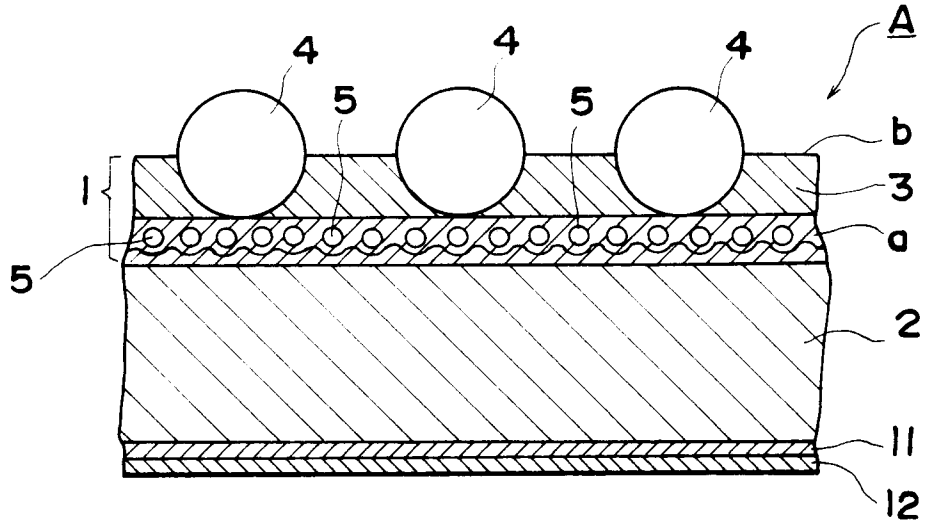

FIG. 1

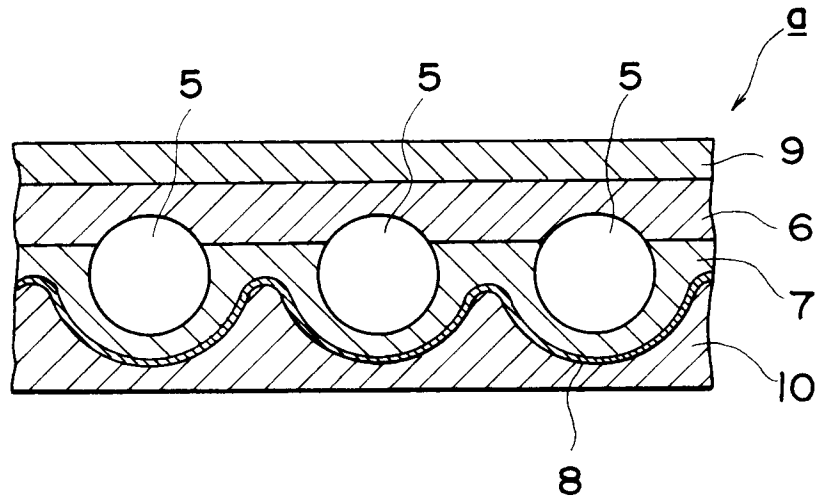

FIG. 2

COMPARISON OF BRIGHTNESS
BETWEEN PRESENT INVENTION
AND PRIOR ART

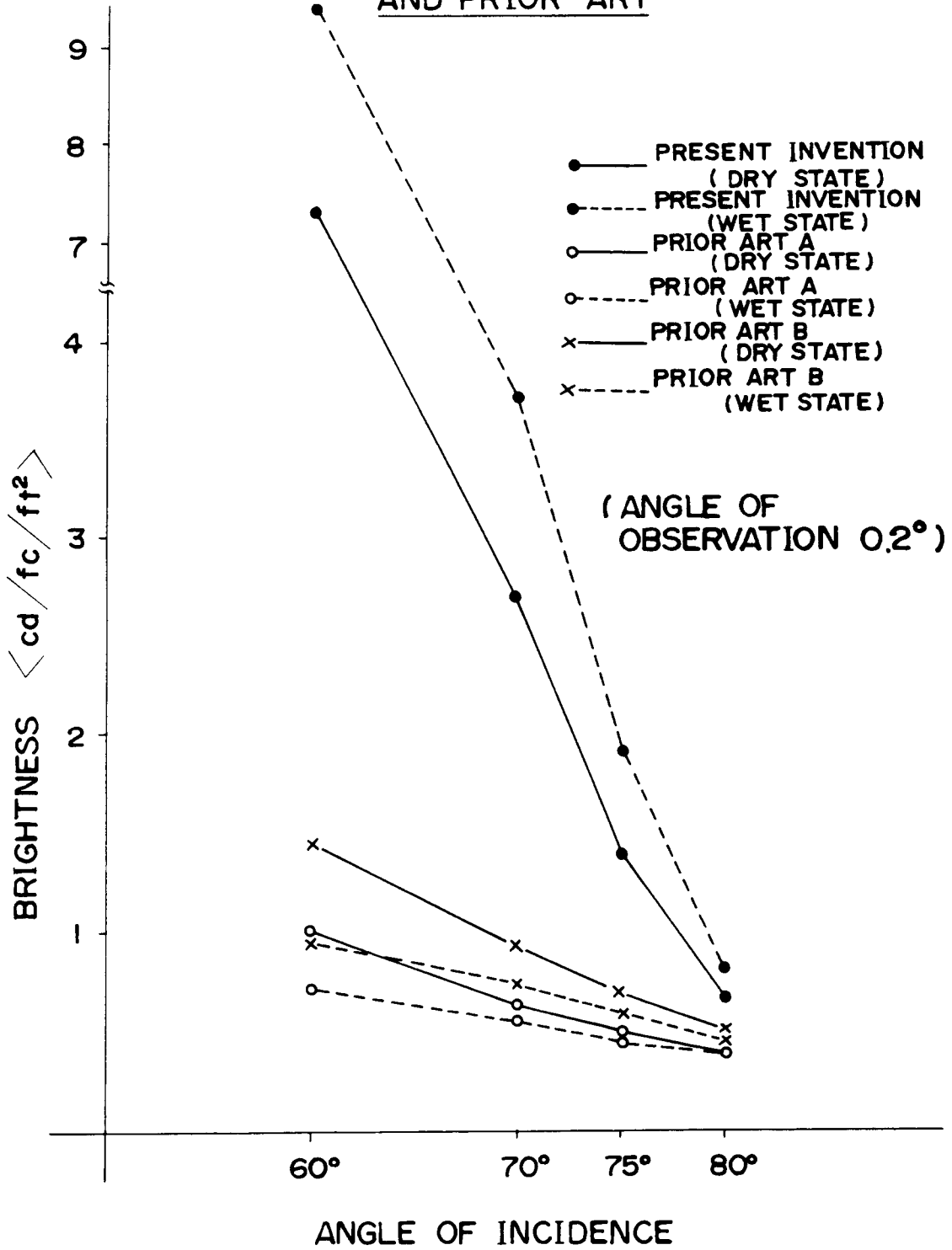

FIG. 3

RELATION BETWEEN FILM THICKNESS
OF FOCUS ADJUSTING RESIN LAYER
AND BRIGHTNESS IN REFLECTION

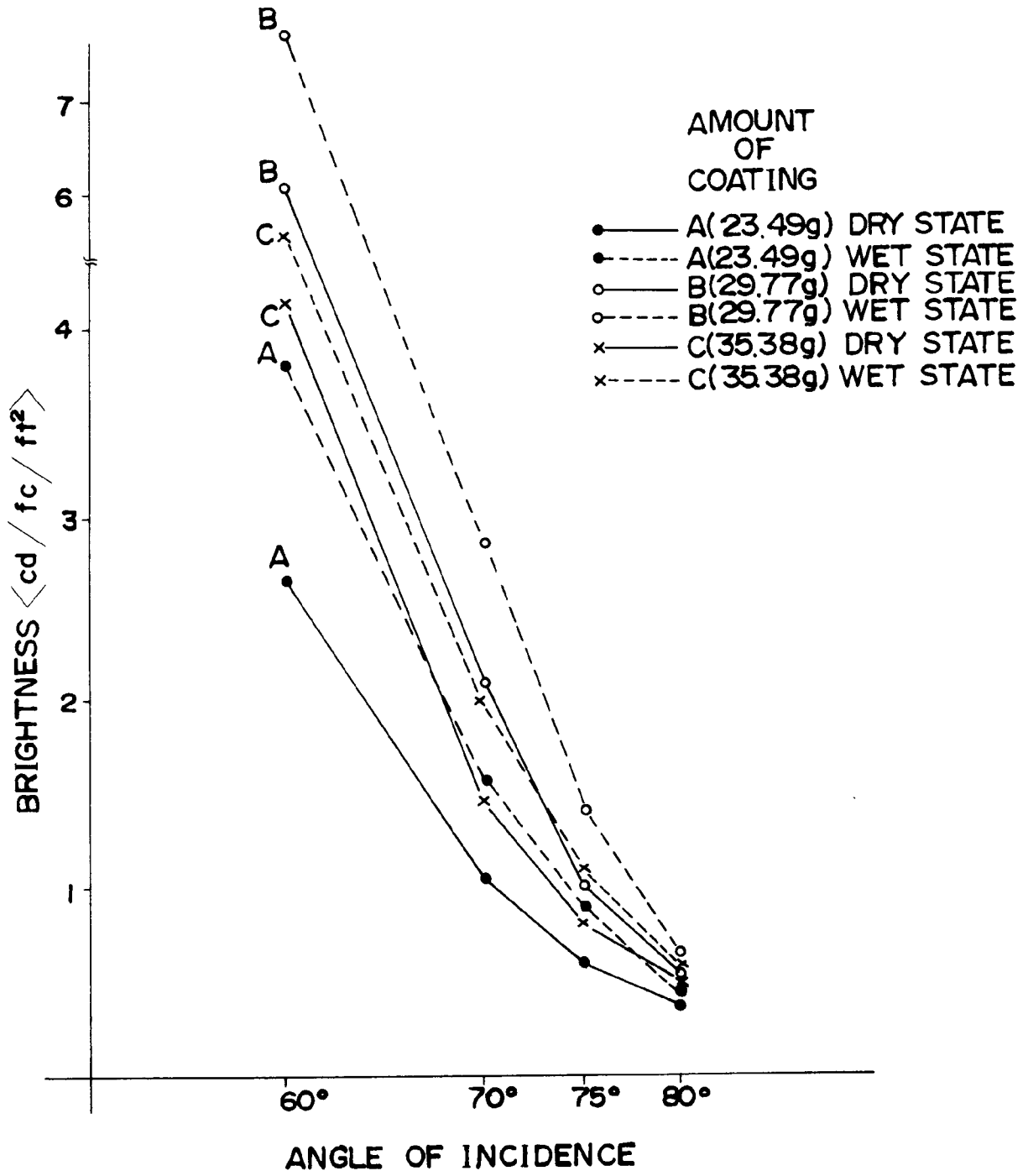

FIG. 4