

64 17 29

FORM 1

SPRUSON & FERGUSON

COMMONWEALTH OF AUSTRALIA
PATENTS ACT 1952
APPLICATION FOR A STANDARD PATENT

NEC Corporation, incorporated in Japan, of 7-1, Shiba 5-chome, Minato-ku, Tokyo, JAPAN, hereby apply for the grant of a standard patent for an invention entitled:

Power Source Control System For Automobile Telephone
which is described in the accompanying complete specification.

Details of basic application(s):-

<u>Basic Applic. No:</u>	<u>Country:</u>	<u>Application Date:</u>
2-47264	JP	1 March 1990

The address for service is:-

Spruson & Ferguson
Patent Attorneys
Level 33 St Martins Tower
31 Market Street
Sydney New South Wales Australia

DATED this FIRST day of MARCH 1991

NEC Corporation

By:



Registered Patent Attorney

TO: THE COMMISSIONER OF PATENTS
OUR REF: 156746
S&F CODE: 56179

6020273 01/03/91

5845/3

DECLARATION IN SUPPORT OF A CONVENTION APPLICATION FOR A PATENT

In support of the Convention Application made for a patent for an invention entitled:

Title of Invention "POWER SOURCE CONTROL SYSTEM FOR AUTOMOBILE TELEPHONE"

Full name(s) and address(es) of Declarant(s) I/We Susumu Uchihara

~~of~~ c/o NEC Corporation of 7-1, Shiba 5-chome, Minato-ku, Tokyo, Japan

do solemnly and sincerely declare as follows:-

Full name(s) of Applicant(s) 1. I am/We are the applicant(s) for the patent-

(or, in the case of an application by a body corporate)

1. I am/We are authorised by NEC Corporation

the applicant(s) for the patent to make this declaration on its/their behalf.

2. The basic application(s) as defined by Section 41 of the Act was/were made

Basic Country(ies) in Japan

Priority Date(s) on the 1st March, 1990

Basic Applicant(s) by NEC Corporation and NEC Saitama, Ltd.

~~3. I am/We are the actual inventor(s) of the invention referred to in the basic application(s)~~
(or where a person other than the inventor is the applicant)

3. Ikio YOSHIDA and Masanori ISHIGAMI

~~of~~ c/o NEC Corporation of 7-1, Shiba 5-chome, Minato-ku, Tokyo, Japan and c/o NEC Saitama, Ltd. of 300-18, Aza Toyohara, Oaza Motohara, Kamikawamachi, Kodama-gun, Saitama, Japan (respectively)

is/are the actual inventor(s) of the invention and the facts upon which the applicant(s) is/are entitled to make the application are as follows:

NEC Corporation was entitled to make the basic application by Contract of Employment between the inventor Ikio YOSHIDA as employee and NEC Corporation as employer to all rights in the invention of this employee and NEC Saitama, Ltd. was entitled to make the basic application by Contract of Employment between the inventor Masahiro ISHIGAMI as employee and NEC Saitama, Ltd. as employer to all rights in the invention of this employee and by a Contract between NEC Corporation and NEC Saitama, Ltd. the rights to apply in Australia resides solely in NEC Corporation.

4. The basic application(s) referred to in paragraph 2 of this Declaration was/were the first application(s) made in a Convention country in respect of the invention the subject of the application.

Declared at Tokyo, Japan this 17th day of January 1991.
NEC Corporation

Susumu Uchihara
Signature of Declarant(s)

Susumu Uchihara
General Manager, Patents Division



AU9172042

(12) PATENT ABRIDGMENT (11) Document No. **AU-B-72042/91**
(19) AUSTRALIAN PATENT OFFICE (10) Acceptance No. **641729**

- (54) Title
POWER SOURCE CONTROL SYSTEM FOR AUTOMOBILE TELEPHONE
- International Patent Classification(s)
(51)⁵ **H04M 019/08 B60R 016/02 B60R 016/04 H04B 001/16**
H04Q 007/04
- (21) Application No. : **72042/91** (22) Application Date : **01.03.91**
- (30) Priority Data
- (31) Number (32) Date (33) Country
2-47264 01.03.90 JP JAPAN
- (43) Publication Date : **05.09.91**
- (44) Publication Date of Accepted Application : **30.09.93**
- (71) Applicant(s)
NEC CORPORATION
- (72) Inventor(s)
IKIO YOSHIDA; MASAHIRO ISHIGAMI
- (74) Attorney or Agent
SPRUSON & FERGUSON , GPO Box 3898, SYDNEY NSW 2001
- (56) Prior Art Documents
AU 70121/91 H04Q 7/4 H04B 1/16
EP 343571
EP 370759
- (57) Claim

1. In a power source control system for a telephone mounted to an automobile and supplied with power from a power source of said automobile, a method of controlling the supply of power from said power source to said telephone by switch means comprising the steps of: controlling the switch means by control means to supply or remove the supply of power to the telephone on the basis of an ON or OFF state respectively of a power switch of said telephone, and, for a change to the OFF state of the power switch, also subject to whether or not a conversation is under way on said telephone, and with no regard to an ON/OFF state of an ignition of said automobile.

64 17 29

S & F Ref: 156746

FORM 10

COMMONWEALTH OF AUSTRALIA

PATENTS ACT 1952

COMPLETE SPECIFICATION

(ORIGINAL)

FOR OFFICE USE:

Class Int Class

Complete Specification Lodged:
Accepted:
Published:

Priority:

Related Art:

Name and Address
of Applicant: NEC Corporation
7-1, Shiba 5-chome
Minato-ku
Tokyo
JAPAN

Address for Service: Spruson & Ferguson, Patent Attorneys
Level 33 St Martins Tower, 31 Market Street
Sydney, New South Wales, 2000, Australia

Complete Specification for the invention entitled:

Power Source Control System For Automobile Telephone

The following statement is a full description of this invention, including the best method of performing it known to me/us

ABSTRACT OF THE DISCLOSURE

A power source control system for an automobile telephone.
The system allows the telephone to be used even when the engine
of an automobile carrying it thereon is in a halt, with no regard
5 to the kind of the ignition switch, i. e., whether the ignition
switch has an accessory position or not.

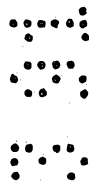
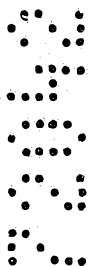

POWER SOURCE CONTROL SYSTEM FOR AUTOMOBILE TELEPHONE

BACKGROUND OF THE INVENTION

5 The present invention relates to a power source control system for an on-board telephone for automobile use and, more particularly, to a power source control system which allows such an on-board telephone to be used even when the engine of an automobile carrying it therewith is ^{stopped} ~~in a halt~~, with no regard to the configuration of an ignition switch.

10 A telephone mounted on an automobile and powered by a power source, or battery, of the automobile belongs to a family of mobile radio telephones which are extensively used today. An automobile has an ignition switch which is operated by a key inserted in a key slot. Ignition switches may generally classified into two types, i. e., a four-position type ignition switch having engine OFF, accessory, engine ON and engine start positions, and a three-position type ignition switch having engine OFF, 15 engine ON and engine start positions. When the ignition switch is brought to the engine start position, the engine of the automobile starts ^{running} ~~operating~~. The accessory position allows an on-board stereo, telephone and other accessories to be used while the engine is ^{stopped} ~~in a halt~~. The accessory position has to be 20



used with care since it causes the accessories to consume ~~the~~ power fed from the power source, or battery, of the vehicle.

5 Assume that a conventional automobile telephone is mounted on an automobile of the type having the four-position ignition switch which includes the accessory position. Then, to use the on-board telephone, the key, ~~may~~^{must} be operated to actuate the ignition switch to the accessory position or to the engine ON position or to actuate it to the engine start position to start the engine and then ^{return} to the engine ON position. When the power switch of the telephone is turned on or is held in an ON state, 10 power is fed from the battery to the telephone. When the power switch of the telephone is turned off or when the key is operated to bring the ignition switch to the engine OFF position, the supply of power to the telephone is interrupted.

15 On the other hand, assume that the automobile on which the conventional vehicle telephone is mounted has the three-position ignition switch which lacks the accessory position. In this case, the telephone is usable only when the key is operated to bring the ignition switch to the engine start position to start the engine and then to the engine ON position. In this condition, when the power switch of the telephone is turned on or held in an ON state, power is fed from the battery to the telephone. When the power switch is turned off or when the key of the automobile is operated to bring the ignition switch to the engine OFF position, 20 the power supply to the telephone is interrupted.

25



As stated above, the drawback with the conventional power source control system for an automobile telephone is that when the vehicle carrying the telephone therewith has the three-position ignition switch, power cannot be fed to the telephone when the ignition of the automobile is in an OFF state. Stated another way, the on-board telephone cannot be used unless the ignition switch is brought to the engine start position to start the engine each time.

SUMMARY OF THE INVENTION

It is therefore an object of the present invention to provide a power source control system for an automobile telephone which, whether the ignition switch of an automobile carrying the telephone therewith has an accessory position or not, allows the telephone to be used even when the engine of the automobile is not running.

It is another preferred object of the present invention to provide a generally improved power source control system for an automobile telephone.

The invention discloses, in a power source control system for a telephone mounted to an automobile and supplied with power from a power source of said automobile, a method of controlling the supply of power from said power source to said telephone by switch means comprising the steps of: controlling the switch means by control means to supply or remove the supply of power to the telephone on the basis of an ON or OFF state respectively of a power switch of said telephone, and, for a change to the OFF state of the power switch, also subject to whether or not a conversation is under way on said telephone, and with no regard to an ON/OFF state of an ignition of said automobile.



BFD/264K

BRIEF DESCRIPTION OF THE DRAWINGS

A preferred embodiment of the invention will now be described with reference to the accompanying drawings, in which:

5 Fig. 1 is a block diagram schematically showing a power source control section of an automobile vehicle telephone and devices associated therewith to which a power source control system embodying the present invention is applied; and

Fig. 2 is a flowchart demonstrating a specific operation of a CPU included in the power source control section.

10 DESCRIPTION OF THE PREFERRED EMBODIMENT

Referring to Fig. 1 of the drawings, a power source control section included in an automobile telephone and implemented with a preferred embodiment of the present invention is shown together with devices associated therewith. The power source control section, 15 generally 10, is connected to an ignition line 12, a power switch 14, and a relay 16. The state of an ignition of a vehicle to which the telephone is mounted is represented by a signal which is fed to the control section 10 over the ignition line 12. The relay 16 connects a power source or battery (not shown) mounted on the vehicle to the 20 telephone via terminals 18 and 20 which are connected to the battery and the telephone, respectively. The control section 10 sends a control signal CONT to the relay 16 to instruct it whether or not to connect the power source and battery terminals 18 and 20, as will be described later specifically. When the control signal CONT is in a 25 high level, the relay 16 closes the contact to connect the terminals 18 and 20 to feed power to the on-board telephone. As the control



8FD/264K

signal CONT goes low, the relay 16 opens the contact to disconnect the terminals 18 and 20 from each other. The ignition line 12 is connected to the ignition key of the vehicle. Usually, when the ignition key is brought to the accessory position or the engine start position, a
5 voltage is applied to the ignition line 12; in the ignition OFF position, the line 12 becomes open. The power switch 14 is a push switch to be manipulated by the operator and which toggles between an ON and OFF state every time it is pressed. For example, the power switch 14 supplies power when pressed once in the power OFF state or
10 interrupts power supply when pressed once in the power ON state. It should be noted that the ON/OFF state of the power supply as selected by the power switch 14 is limited by whether or not a conversation is under way, as will be described specifically later.

The power source control section 10 has a CPU or similar
15 processor 22 and peripheral circuitry associated therewith. The CPU 22 may be implemented by μ PD70008 or μ PD70108 available

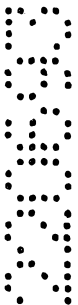

from NEC. The peripheral circuitry is constantly powered by the automobile power source 18 while the CPU 22 is powered through the terminal 20. More specifically, the CPU 22 starts operating on the connection of the telephone power source terminal 20 to the battery terminal 18.

5

The peripheral circuitry includes an inverter gate 24 whose input is connected to the ignition line 12. A NAND gate 26 is connected at one input thereof to the output of the inverter gate 24. An inverter gate 28 is connected to the output of the NAND gate 26. An inverter gate 30 is connected at the input thereof to the power switch 14 and at the output thereof to a clock input CK of a D flip-flop 32. The D flip-flop 32 has an inverting output \bar{Q} thereof connected to one input of a NAND gate 34. The NAND gate 34 feeds an output thereof to the relay 16 as a control signal CONT. The inverting output \bar{Q} of the flip-flop 32 is also connected to a data input D of the flip-flop 32. An n-p-n transistor 36 has a base connected to the output of the inverter gate 24, a collector connector to the CPU 22, and an emitter connected to ground. An n-p-n transistor 38 has a base connected to the non-inverting output Q of the D flip-flop 32, a collector connected to the CPU 22, and an emitter connected to ground. Further, an n-p-n transistor 40 has a base connected to the CPU 22, a collector connected to the other inputs of the NAND gates 26 and 34, and emitter connected to ground. The input of the inverter gate 30 is connected to the automobile

10

15

20

25

battery terminal 18 via a pull-up resistor 42. The reset input R of the D flip-flop 32 is connected to ground via a resistor 44 and to the output of the inverter gate 28 via a capacitor 46. The set input S of the D flip-flop 32 is connected to ground via a resistor 48 and to the output of the NAND gate 26 via a capacitor 50. The collector of the transistor 40 is also connected to the automobile power source 18 via a pull-up resistor 52. The collectors of the transistors 36 and 38 are connected to the telephone power source terminal 20 via pull-up resistors 54 and 56, respectively.

The CPU 22 feeds a signal to the base of the transistor 40 on the basis of the states of the collectors of the transistors 36 and 38 and whether or not the telephone is in use, according to a specific procedure shown in Fig. 2.

The operation of the power source control circuit 10 will be described with reference also made to Fig. 2.

First, how the telephone is turned on and off by the power switch 14 with no regard to the state of the ignition will be described. Assume that the telephone is in an OFF state, i. e., the terminal 20 is ^{disconnected from} ~~connected to~~ the battery terminal 18, and the ignition line 12 is in a high level. Then, as the power switch 14 is pushed once, one high-level pulse is fed to the clock input CK of the D flip-flop 32 via the inverter gate 30. In response, the inverting output \bar{Q} of the D flip-flop 32 goes low despite that the data input D of the flip-flop 32 is in a high level. The low level



on the inverting output \bar{Q} of the flip-flop 32 causes the NAND gate 34 to feed a high-level signal to the relay 16 as a control signal CONT, whereby the telephone power source terminal 20 is connected to the battery terminal 18 and, therefore, the CPU 22 ^{is} ~~are~~ activated. In response, the CPU 22 executes steps S1 to S4 shown in Fig. 2 and then an iterative loop of steps S5 to S7. In the step S4, the CPU 22 feeds a low-level signal to the base of the transistor 40.

When the power switch 14 is pushed again, the inverting output \bar{Q} of the D flip-flop 32 is inverted to a high level. As a result, the NAND gate 34 delivers a low-level signal to the relay 16 as a control signal CONT and thereby turns off the telephone.

Assume that the telephone is in an OFF state, and the ignition line 12 is in a low level. When the power switch 14 is pushed once, a high-level control signal CONT is fed to the relay 16 to thereby turn on the telephone. This in turn causes the CPU 22 to start operating. In this case, the CPU 22 executes the steps S1 to S3 and then an iterative loop of steps S13 to S15 by way of a step S12. In the step S12, the CPU 22 feeds a high-level signal to the base of the transistor 40 with the result that the collector of the transistor 40 goes low. Consequently, the output of the NAND gate 26 turns from low to high to thereby charge the capacitor 50 via the resistor 48. At this instant, one high-level pulse is fed to the set input S of the D flip-flop 32. However, the state of the D flip-flop 32 does not



change because the inverting output \overline{Q} of the flip-flop 32 has already gone low.

When the power switch 14 is pushed again, the inverting output \overline{Q} of the flip-flop is inverted to a high level. However, since the collector of the transistor 40 is in a low level, the output of the NAND gate 34 remains in a high level. In the step S14, the CPU 22 detects the change of the collector of the transistor 38 from a low level to a high level. Then, in a step S23, the CPU 22 causes the base of the transistor 40 into a low level and thereby the output of the NAND gate 34 into a low level. As a result, the telephone is turned off.

The telephone is also turned on and off in response to the change of the ignition from OFF to ON and from ON to OFF, as follows.

Assume that the ignition line 12 has gone high while the telephone remains in an OFF state. Then, the output of the inverter gate 28 goes low with the result that one high-level pulse is fed to the reset input R of the D flip-flop 32. This pulse causes the inverting output \overline{Q} of the D flip-flop 32 into a low level and thereby connects the telephone power source terminal 20 to the battery terminal 18, whereby the CPU 22 is powered. In response, the CPU 22 executes the loop of steps S5 to S7 by way of the steps S1 to S4. A low level is fed to the base of the transistor 40, so that the state of the D flip-flop 32 does not change. On the change of the ignition line 12 from a high level

to a low level, the output of the NAND gate 26 goes low. This causes the output of the inverter gate 28 to turn from low to high to thereby charge the capacitor 46 via the resistor 44. At this instant, one high-level pulse is fed to the reset input R of the D flip-flop 32. In response, the inverting output \bar{Q} of the D flip-flop 32 goes high to turn off the telephone.

When the state of the ignition changes from ON to OFF while a conversation is under way on the on-board telephone, the embodiment holds the telephone in the ON state until the conversation ends, as follows.

Assume that the ignition line 12 is in a high level with the telephone being held in an ON state. Then, since a conversation is held, the CPU 22 has already entered an iterative loop of steps S9 to S11 by way of a step S8. The inverting output \bar{Q} of the D flip-flop 32 is in a low level. In the step S3, the CPU 22 feeds a high-level signal to the base of the transistor 40. In this condition, when the ignition line 12 goes low, the output of the NAND gate 26 remains in a high level since the collector of the transistor 40 is in a low level. On the other hand, the collector of the transistor 36 goes low with the result that the CPU 22 executes a step S25 on the basis of the result of decision in the step S9 and then enters a loop of steps S16 to S18. This loop is repetitively executed so long as the power switch 14 is not pushed during conversation. When the conversation is ended, the CPU 22 advances to a step S26 by way of the step S18 and a

step S19, i. e., it feeds a low level signal to the base of the transistor 40. As a result, the output of the NAND gate 26 goes low to turn the output of the inverter gate 28 from low to high to thereby feed one high-level pulse to the reset input R of the D flip-flop 32, whereby the telephone is turned off.

When it is desired to turn off the telephone by the power switch 14 while a conversation is under way, the telephone is turned off after end-of-conversation processing, as follows.

Assume that the telephone is in an ON state, and that the ignition line 12 is in a high level. In such a condition, the CPU 22 is executing the iterative loop of steps S9 to S11. When the power switch 14 is pushed once, the inverting output \bar{Q} of the D flip-flop 32 goes high. However, since the collector of the transistor 40 is in a low level, the CPU 22 executes a step S20, i. e., end-of-conversation processing on the basis of the result of decision in the step S10. Subsequently, the CPU 22 changes the base of the transistor 40 from a high level to a low level, step S20. As a result, the output of the NAND gate 34 goes low to turn off the telephone. On the other hand, assume that the ignition line 12 is in a low level and, therefore, the CPU 12 is executing the loop of steps 16 to 18. When the power switch 14 is pushed once, the inverting output \bar{Q} of the D flip-flop 32 goes high. However, since the collector of the transistor 40 is in a low level, the output of the NAND gate 34 remains in a high level. Since the collector of the transistor 38 goes high, the CPU

22 executes the end-of-conversation processing, step S20, and then causes the base of the transistor 40 into a low level. As a result, the output of the NAND gate 34 goes low and thereby turns off the telephone.

5 In summary, it will be seen that the present invention provides a power source control system for an automobile telephone which controls the supply of power to the telephone by a power switch with no regard to the state of an ignition of an automobile on which the telephone is mounted. Therefore, whether the ignition switch has an accessory
10 position or not, the telephone can be used even when the engine of the automobile is stopped and, therefore, achieves unprecedented freedom. Further, the supply of power to the telephone is automatically set up on the change of the ignition from OFF to ON and is automatically interrupted on the change thereof from ON to OFF if there is no
15 conversation underway. The user of the telephone, therefore, does not have to turn the power switch on and off each time.

Various modifications, as will be apparent to those skilled in the art, are to be considered within the scope of the present invention.

2
3
4

5
6
7
8
9



The claims defining the invention are as follows:

1. In a power source control system for a telephone mounted to an automobile and supplied with power from a power source of said automobile, a method of controlling the supply of power from said power source to said telephone by switch means comprising the steps of: controlling the switch means by control means to supply or remove the supply of power to the telephone on the basis of an ON or OFF state respectively of a power switch of said telephone, and, for a change to the OFF state of the power switch, also subject to whether or not a conversation is under way on said telephone, and with no regard to an ON/OFF state of an ignition of said automobile.

2. A method as claimed in claim 1, wherein, when said ignition changes from an ON state to an OFF state while a conversation is under way on said telephone, performing the further step of continuously connecting said power source and said telephone whereby the supply of power to said telephone is continued until the conversation ends.

3. A method as claimed in claim 1, wherein, when said ignition is in either an ON state or an OFF state while a conversation is under way on said telephone, performing the further step of interrupting the supply of power to said telephone as soon as said power switch is operated to end the conversation.

4. A method as claimed in claim 1, wherein, when said ignition changes from an OFF state to an ON state, performing the further step of connecting said power source of said automobile to said telephone to effect the supply of power.

5. A power supply control system for a telephone which is mounted to an automobile and having a power switch to which power is supplied from a power source of said automobile, comprising:
switch means for electrically connecting said telephone with said power source of said automobile; and
control means for controlling the supply or removal of power from said automobile to said power source by driving said switch means on the basis of an ON/OFF state of said power switch, and for the OFF state of the power switch, dependant whether or not a conversation is under way on said telephone, and with no regard to an ON/OFF state of said ignition.

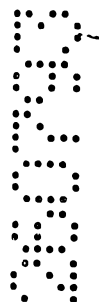
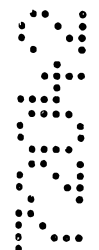

6. A system as claimed in claim 5, wherein said control means controls said switch means such that said ignition changes from an ON state to an OFF state while a conversation is under way on said telephone, said power source of said automobile is continuously supplied to said telephone until the conversation ends.

7. A system as claimed in claim 5, wherein said control means controls said switch means such that, when said ignition is in an ON state or an OFF state while a conversation is under way on said telephone, the supply of power to said telephone is interrupted as soon as said power switch is operated to end the conversation.

DATED this TWENTY-FIRST day of JUNE 1993

NEC Corporation

Patent Attorneys for the Applicant
SPRUSON & FERGUSON

2
2
2
2

2
2
2
2



Fig. 2A

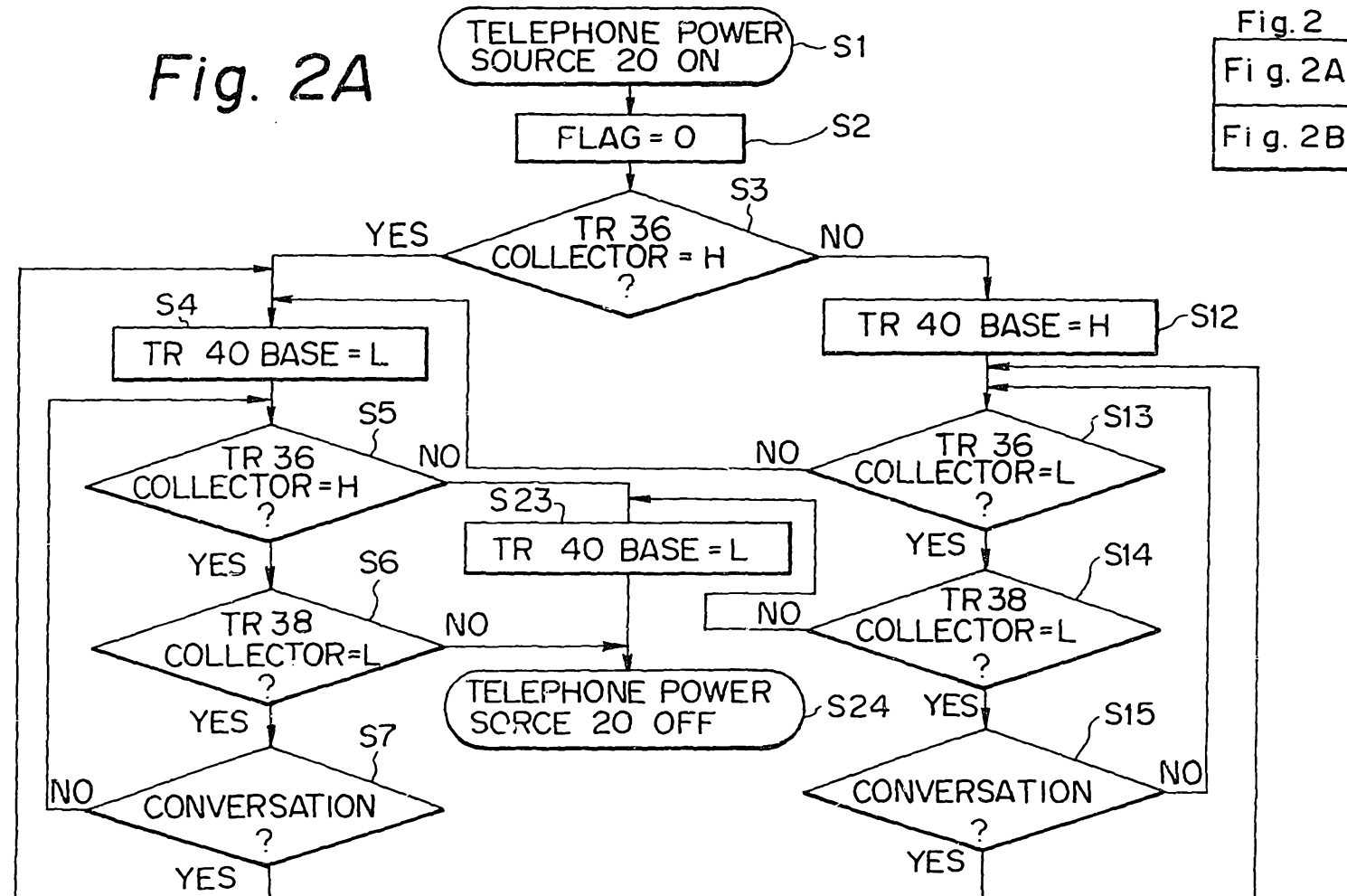

Fig. 2
Fig. 2A
Fig. 2B

Fig. 2B

