



- (51) **International Patent Classification:**
A61F 2/06 (2013.01) *A61F 2/958* (2013.01)
- (21) **International Application Number:**
PCT/IB2013/000217
- (22) **International Filing Date:**
31 January 2013 (31.01.2013)
- (25) **Filing Language:** English
- (26) **Publication Language:** English
- (30) **Priority Data:**
61/593,704 1 February 2012 (01.02.2012) US
- (72) **Inventor; and**
- (71) **Applicant : FELD, Tanhum** [IL/IL]; 19105 Moshav Merhavaya (IL).
- (72) **Inventor: KONSTANTINO, Eitan**; 29 Meadow Park Court, Orinda, CA 94563 (US).
- (74) **Agent: REINHOLD COHN AND PARTNERS**; P.O.Box 13239, 6113102 Tel-Aviv (IL).
- (81) **Designated States** (unless otherwise indicated, for every kind of national protection available): AE, AG, AL, AM, AO, AT, AU, AZ, BA, BB, BG, BH, BN, BR, BW, BY, BZ, CA, CH, CL, CN, CO, CR, CU, CZ, DE, DK, DM,

DO, DZ, EC, EE, EG, ES, FI, GB, GD, GE, GH, GM, GT, HN, HR, HU, ID, IL, IN, IS, JP, KE, KG, KM, KN, KP, KR, KZ, LA, LC, LK, LR, LS, LT, LU, LY, MA, MD, ME, MG, MK, MN, MW, MX, MY, MZ, NA, NG, NI, NO, NZ, OM, PA, PE, PG, PH, PL, PT, QA, RO, RS, RU, RW, SC, SD, SE, SG, SK, SL, SM, ST, SV, SY, TH, TJ, TM, TN, TR, TT, TZ, UA, UG, US, UZ, VC, VN, ZA, ZM, ZW.

- (84) **Designated States** (unless otherwise indicated, for every kind of regional protection available): ARIPO (BW, GH, GM, KE, LR, LS, MW, MZ, NA, RW, SD, SL, SZ, TZ, UG, ZM, ZW), Eurasian (AM, AZ, BY, KG, KZ, RU, TJ, TM), European (AL, AT, BE, BG, CH, CY, CZ, DE, DK, EE, ES, FI, FR, GB, GR, HR, HU, IE, IS, IT, LT, LU, LV, MC, MK, MT, NL, NO, PL, PT, RO, RS, SE, SI, SK, SM, TR), OAPI (BF, BJ, CF, CG, CI, CM, GA, GN, GQ, GW, ML, MR, NE, SN, TD, TG).

Published:

- with international search report (Art. 21(3))
- before the expiration of the time limit for amending the claims and to be republished in the event of receipt of amendments (Rule 48.2(h))

(54) **Title:** DEVICE FOR COMPARTMENTAL DILATATION OF BLOOD VESSELS

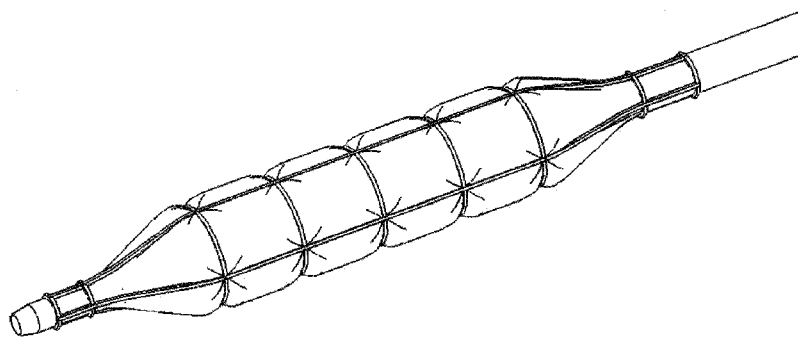

FIG. 2A

(57) **Abstract:** A constraining structure for use with a balloon catheter includes multiple longitudinal struts and multiple expandable radial rings. The constraining structure can expand radially but may not expand substantially in the longitudinal direction. The constraining structure can have multiple compartments configured to expand independently of one another. Inflating the balloon catheter within the constraining structure can allow for dilation of the blood vessel in a pre determined topography.



DEVICE FOR COMPARTMENTAL DILATATION OF BLOOD VESSELS

INCORPORATION BY REFERENCE

[0001] All publications, patents, and patent applications mentioned in this specification are herein incorporated by reference to the same extent as if each individual publication, patent, or patent application was specifically and individually indicated to be incorporated by reference.

BACKGROUND OF THE INVENTION

Field of the Invention

[0002] The present invention relates to the field of medical methods and devices, specifically to medical dilatation balloon catheters and devices intended to treat blood vessel obstructions and/or deliver active substance to body tissue.

[0003] Angioplasty balloons are one of the most commonly used tools for treatment of narrowed and occluded blood vessels. These balloons are typically cylindrical when inflated and are manufactured in various dimensions (length and diameter) to conform to different vessel size. Balloons are located at the distal end of flexible catheters and delivered to a target site/lesion where they are inflated, normally between 8-20 atmospheres, in order to overcome the resistance of the lesion and achieve luminal expansion. Such high pressure angioplasty is often associated with trauma to the vessel walls with a resulting high frequency of vessel dissection (30%-40%), abrupt closure of the treated vessel (5%-12%), and restenosis. When conventional angioplasty is used as a primary treatment for occluded vessels, restenosis can occur in about 50% of the cases. Therefore in the vast majority of coronary treatments, angioplasty is used as an initial treatment followed by placement of a stent. Frequently the stents are coated with drug and polymer requiring the patient to take anti platelet therapy for extended periods, possibly lifelong, to limit the risk of stent thrombosis or blood clots.

necessary to apply more and more pressure until the stenosis gives way. This is an abrupt and forceful process that may result in severe trauma to the vessel wall that in the best case further delays the healing of the lesion and in the worst and not uncommon case result in dissections, abrupt closure and restenosis.

[0005] Dissections in the treated blood vessel due to balloon dilation are very common. The dissection rate is estimated as high as 30% of the cases. Some of these are severe and may require urgent surgery or placement of additional stents. In addition, dissection may contribute to poor long term clinical results and restenosis even if a stent is placed in the treated lesion. Dissections are attributed to several mechanisms occurring during balloon inflation including the shear forces applied on the vessel walls as the balloon pleats unfold and uneven inflation of the balloon due to inconsistency of the disease in the vessel. During inflation, while the balloon diameter increases in the radial direction, the folded balloon is unwrapped and applies tangential forces (See Fig 1A, 1B and 1C). Attempts have been made to resolve this problem by providing fully elastic or stretchable balloons that open radially without unfolding. However, those balloons, made of elastic materials could not provide sufficient dilatation forces since the materials are soft and compliant not capable of high pressure inflation.

[0006] The disease is not uniform and the inner diameter of the vessel can be characterized as anisotropic. Standards angioplasty balloons are commonly elastic or semi-compliant, and are designed to increase their diameter, and therefore apply force on the surrounding area in a uniform way. When inflated against an inconsistent resistance (eccentric lesions, focal plaque) it will be necessary to apply increased pressure until the plaque gives way and the balloon is fully inflated. This abrupt and uncontrolled process causes increased trauma to the area. Furthermore, at the initial stage of the elastic nature of a balloon cause its diameter to increase more at the elastic (and less diseased) areas of the vessel causing further trauma and delayed healing.

[0007] Long lesions (typical of peripheral lesions) create additional challenges. These lesions often require repeated inflation/deflations while progressing through the occluded vessel. This requires a consistency in the quality of performance that is not typical

cause further damage to non-diseased areas. Since the lengthening of the balloon is relative to its length, this is especially pronounced in treating long lesions.

[0008] Dissections, elastic recoil and abrupt closure are all mechanisms associated with current angioplasty balloons having a high level of injury and trauma to the treated vessel.

[0009] Therefore, it would be desirable to provide improved balloons and inflation structures for angioplasty balloons used in vascular treatments. In particular, a balloon that has less tendency to cause trauma and dissection to the blood vessel wall by modulating the inflation characteristics of the balloon and providing segmental compartmental dilation with local areas of compliance. Furthermore a controlled inflation that allows for a slow plaque remodeling and modification process can prove to be less traumatic and promote faster healing of the lesion.

[0010] It would be further desirable if the reduced dissections could also reduce the risk of elastic recoil and abrupt re-closure which are associated with current angioplasty balloons and their use. It would be further desired if such improved angioplasty balloon structures were compatible with each of stents, drug-eluting stents, and drug coated balloons. These advantages would preferably be obtained without loss of the ability of the catheters to increase the luminal size and restore blood vessel in the patient being treated. At least some of these objectives will be met by the invention as described hereinafter.

SUMMARY OF THE INVENTION

[0011] This invention discloses a device for angioplasty or dilatation of stenotic vessels and optionally for the delivery of active substance to the vessel wall. The balloon catheter disclosed here is designed to support a controlled and regulated plaque remodeling process promoting faster healing of the diseased area. This is achieved by modulation of the inflation characteristic resulting in less trauma to vessel wall during inflation.

[0012] This balloon catheter consists of a balloon catheter and a Constraining Structure (CS) located on the balloon portion of the catheter. The Constraining Structure (CS) serves to control and limit balloon inflation by modifying balloon topography and creating

topography helps to promote plaque remodeling during inflation and allow for a controlled inflation with minimized trauma to vessel wall. The CS also inhibits transfer of shear forces to the lesion and vessel wall as the balloon inflates.

[0013] As the balloon inflates both balloon and CS structure increase in diameter however the CS maximal diameter is smaller than the balloon diameter. The balloon continues to inflate through the CS creating a topography of hills (pillows) and valleys (CS locations). The CS and balloon are capable of expanding due to inflation force applied by balloon dilation. The CS expansion is limited by its geometrical design. The CS is designed to limit balloon diameter, to eliminate transfer of tangential forces to vessel wall and to allow a plaque remodeling process that minimizes trauma and promotes faster healing.

[0014] A conventional balloon is compliant or semi-compliant and has a smooth even surface. During inflation the balloon will expand more easily in areas of less resistance, such as the less diseased areas (see Image 4A to 4C). In order to successfully open the lesion it is necessary to apply more pressure then when pressure is high enough the lesion will “give in” and open abruptly. This inflation process is fast and aggressive and may cause severe trauma. The device described in this invention is designed to allow a slow process of plaque remodeling where the plaque is able to flow and reshape itself due to the topography created by the CS. It creates a series of cushions where the CS is located at valleys between them (see Fig 3). The CS channels between the cushions prevent high pressure buildup in the plaque and over expansion of the dilated vessel thus minimizing trauma caused to vessel walls during inflation. Thus the inflation process is controlled resulting in less trauma to the vessel and faster healing of the area.

[0015] The CS is situated over the deflated and folded balloon and attached to the catheter near the distal end of the balloon or near the proximal end of the balloon or preferably both. It also can be placed over the balloon without attachment. Upon balloon inflation the CS expands and allows the dilatation of the vessel by the balloon in a pre determined topography. During balloon dilation both the balloon and the CS structure increase in diameter while length of the device does not change. This further modulates the mechanics of inflation by minimizing the creation of axial tension forces on the vessel wall.

inflation the CS structure and balloon effective length do not change. When balloon length is maintained throughout the inflation process it allows predictability and more control of the inflation mechanism, and the healthy areas of the vessel are not exposed to inflation and tension forces exposing them to further damage.

BRIEF DESCRIPTION OF THE DRAWINGS

[0016] The novel features of the invention are set forth with particularity in the appended claims. A better understanding of the features and advantages of the present invention will be obtained by reference to the following detailed description that sets forth illustrative embodiments, in which the principles of the invention are utilized, and the accompanying drawings of which:

[0017] Fig 1A to 1 C show a cross-section of the stages of unwrapping of conventional balloon inflation in a stenotic blood vessel.

[0018] Fig 2A and 2B show this invention where a Constraining Structure is located on the balloon creating a controlled topography of hills and valleys during inflation.

[0019] Figs 3A to 3C show a cross-section of the dilatation device in this invention during 3 different stages of inflation while unwrapping occur within the constraining device.

[0020] Figs 4 A to 4C show 3 inflation stages of a conventional balloon.

DETAILED DESCRIPTION OF THE PREFERRED EMBODIMENT

[0021] This invention discusses a device for treating of diseased, blocked, occluded or stenotic lumens in the body, typically blood vessels including both arteries and veins, and more typically coronary and peripheral arteries. This device dilates occluded vessels while causing minimal trauma to the lesion thus minimizing the risk of dissections, total occlusion, abrupt closure and restenosis, and promotes faster healing.

[0022] A Constraining Structure (CS) is placed over a balloon catheter where upon inflation both the balloon and the CS increase in diameter and during deflation the CS returns to its original dimensions. The CS can have multiple designs intended to expand to a diameter smaller than the maximal inflated diameter of the balloon. The CS can be connected to the balloon either on the distal side or the proximal side or both. It can also float over the

maintain its length during expansion and therefore there is no relative axial movement between the CS and the balloon. It can be made from various materials, processes and designs. It can be made from metal, preferable a very elastic metal such as Nitinol and it can be made from variety of polymers (e.g. Nylon). It can be constructed from wires or laser cut from a tube, sheath or other forms of materials.

[0023] In a preferred embodiment of this invention the CS is over the balloon. During inflation the CS expands allowing the balloon to expand under it. The maximum CS diameter is smaller than that of the inflated balloon, thus the balloon protrudes and expands through the CS creating a topography of hills and valleys. The CS structure creates a combination of a designed topography and controlled, slower inflation promoting a process of plaque remodeling. The plaque in the diseased area of the vessel is able to flow through the valleys in the designed topography, and re-distribute in the vessel allowing a gradual inflation without the need to apply added pressure.

[0024] Referring to Figures 4A to 4C, in a conventional balloon during inflation, due to balloon compliance, the balloon will expand toward areas of less resistance (healthy areas or areas with less plaque buildup -see Fig 4B). In order to successfully dilate the lesion additional pressure should be applied until the lesion areas with more severe blockage yields and the balloon can inflate entirely (see Fig 4C). This process is abrupt and aggressive exposing vessel wall (healthy or diseased areas) to severe trauma and may result in dissection, restenosis and a slower healing process. The topography created by the CS allows for the plaque to gradually re-disperse and flow through the CS valleys (see Fig 2A and 2B) while the catheter expands and the inflation is gradual and controlled. The design of the CS allows for plaque remodeling creating less trauma and promotes faster healing.

[0025] In one embodiment of this invention, the CS is attached to both ends of the balloon and is capable of maintaining a constant length during inflation and deflation processes. During inflation the CS structure expands to a pre-designed diameter that is smaller than the balloon inflated diameter. The balloon continues to expand beyond the CS but is restricted in length by the CS structure. Referring to Figure 2B, the balloon inflates through the CS structure and is restricted in length by the CS design, thus allowing the device

or eliminating axial forces applied on vessel wall and minimizing trauma to vessel. Furthermore this allows more predictability in inflation process. This is especially effective in long balloons (commonly used in peripheral arteries).

[0026] In one embodiment of this invention the CS is constructed of radial rings connecting by axial wires. Upon inflation the CS expands radially without any axial lengthening. This structure allows a compartmental inflation process where the rings create separate inflation zones within the vessel. Therefore the pressure to the vessel wall is controlled and is applied in the radial direction without any strain in the axial direction reducing trauma and possible dissections.

[0027] The present invention can be utilized to deliver various agents or active substances particularly (but not limited to) those suitable for treating vascular and other luminal conditions such as antiproliferative and antimitotic agents (such as paclitaxel and sirolimus) other substances can include antibiotics, antiplatelet agents hormones and more.

[0028] The active substance can be placed in various designs or techniques such as directly coated on the balloon surface, the CS or both. It can be embedded in a matrix/carrier placed on the balloon or the CS or both. The combination of low trauma dilatation with release of active agent can be superior to drug eluting stents for some portions of the population by minimizing the need for a permanent implant yet providing good long term results.

[0029] In one embodiment the balloon surface is coated with drug. Upon balloon inflation, the 'pillows'/hills formed in the balloon external surface coated with drug engage the vessel wall and compress the drug into the wall to facilitate efficient drug delivery to the treated site.

[0030] Drug delivery can be facilitated using many different design methods including but not limited to coating the balloon, coating the CS structure or both. Coating with a drug directly or using a carrier in a form of a matrix or microcapsules.

1. A balloon catheter, the balloon catheter comprising an expandable balloon carried on the catheter; and a radially expandable constraining structure disposed on the balloon, wherein the constraining structure comprises an expanded diameter smaller than an inflated diameter of the balloon, and wherein the constraining structure comprises a plurality of compartments configured to define a plurality of portions of the balloon to expand independently of each other.
2. The balloon catheter of claim 1, wherein at least one of the constraining structure and the balloon catheter comprises an active substance delivery mechanism.
3. The balloon catheter of claim 2, wherein the delivery mechanism comprises a carrier and/or coating.
4. A constraining structure for constraining expansion of an inflatable balloon, the constraining structure comprising one or more expandable radial rings; and one or more longitudinal struts connecting the constraining rings, wherein the constraining structure is configured to be non deployably positioned over a balloon catheter.
5. The constraining structure of claim 4, wherein the constraining structure comprises at least one of a metal or a polymer.
6. The constraining structure of claim 4, wherein the constraining structure is formed from wires or is laser cut from a tube.
7. The constraining structure of claim 4, wherein the longitudinal struts are substantially non-expandable.
8. The constraining structure of claim 4, wherein the radial rings are configured to expand independently of each other.
9. A method for deploying a balloon catheter, the method comprising Providing a balloon catheter having a constraining structure mounted over the balloon;

inflating the balloon thereby causing dilation of the vessel in a pre determined non-cylindrical topography.

10. The method of claim 9, wherein inflating the balloon causes the constraining structure to expand.

11. The method of claim 10, wherein a length of the balloon and the constraining structure remains substantially constant while causing the constraining structure to expand.

12. The method of claim 9, wherein inflating the balloon causes the balloon to protrude and expand through windows in the constraining structure.

13. The method of claim 9, wherein inflating the balloon creates a topography of hills and valleys.

14. The method of claim 9, wherein inflating the balloon comprises gradually inflating the balloon.

15. The method of claim 9, further comprising delivering an active substance to the vessel.

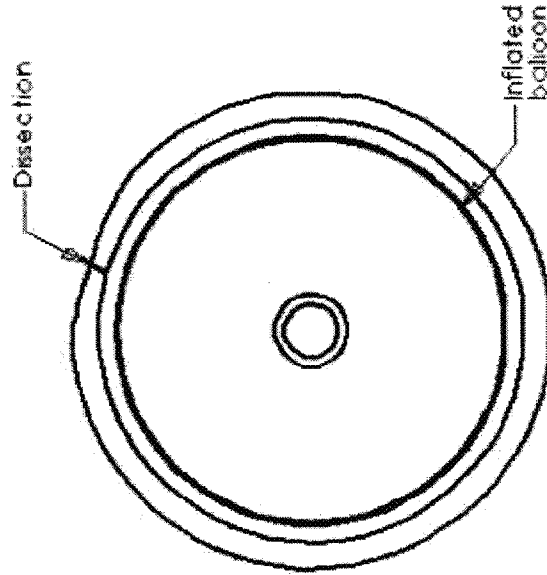

Figure 1C
End of inflation

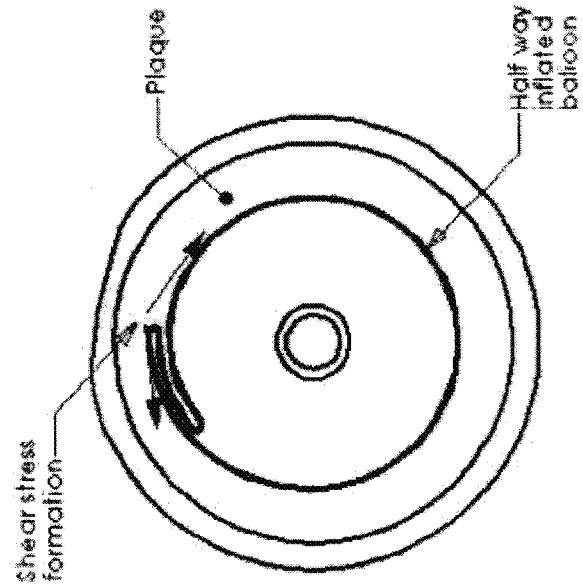

Figure 1B
During inflation

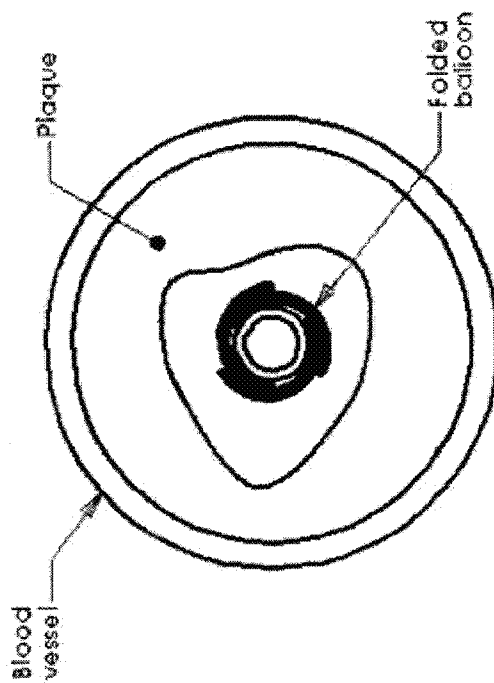

Figure 1A
Pre - inflation

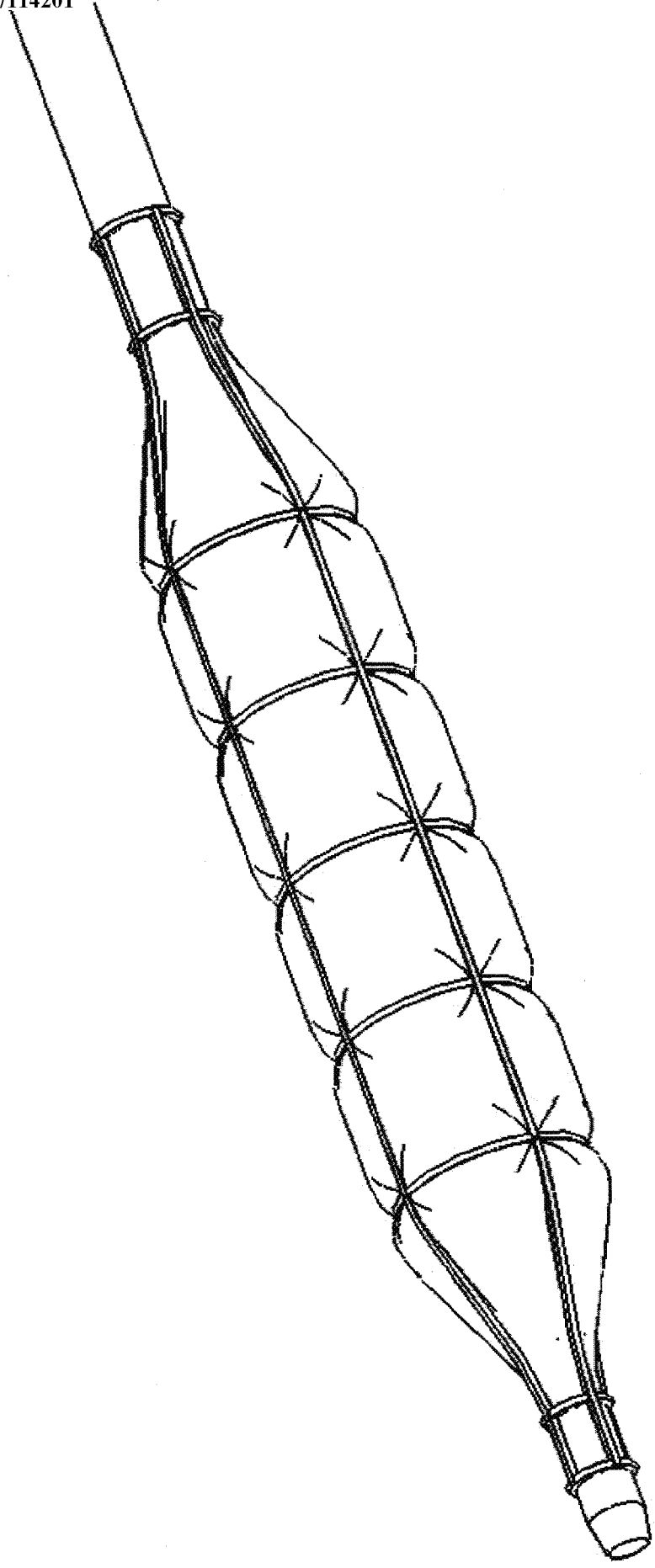

FIG. 2A

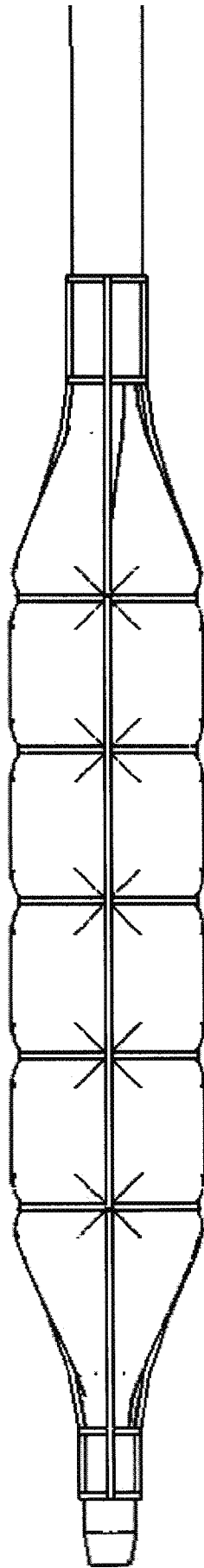
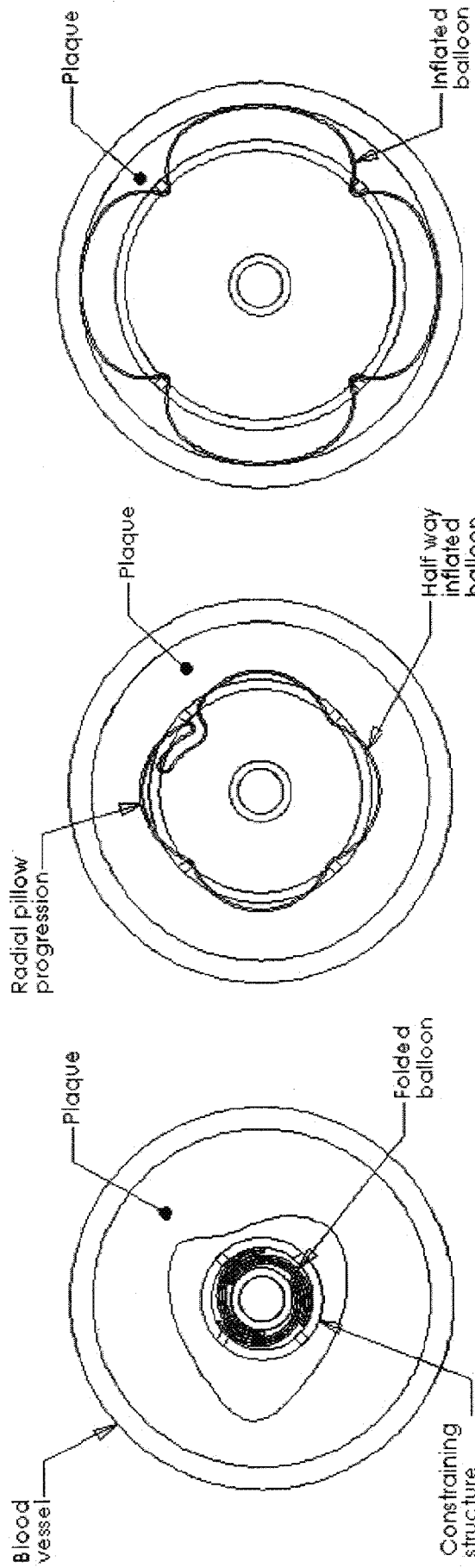

FIG. 2B



End of inflation

FIG. 3C

During inflation

FIG. 3B

Pre - inflation

FIG. 3A

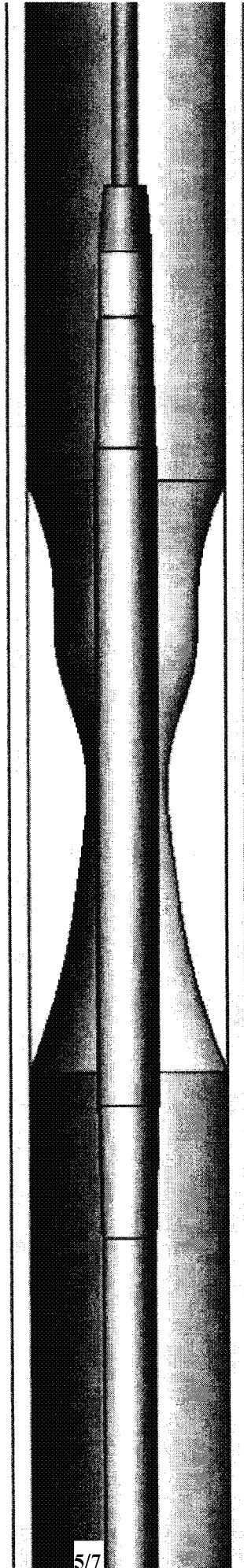

FIG. 4A

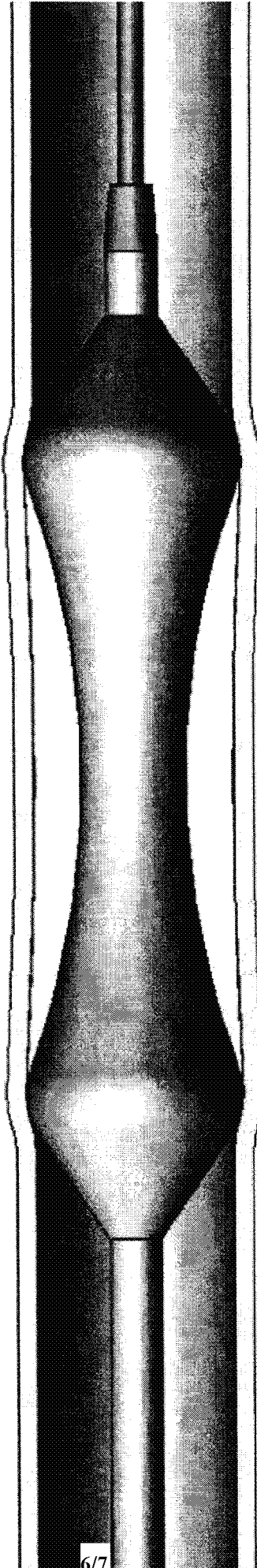

FIG. 4B

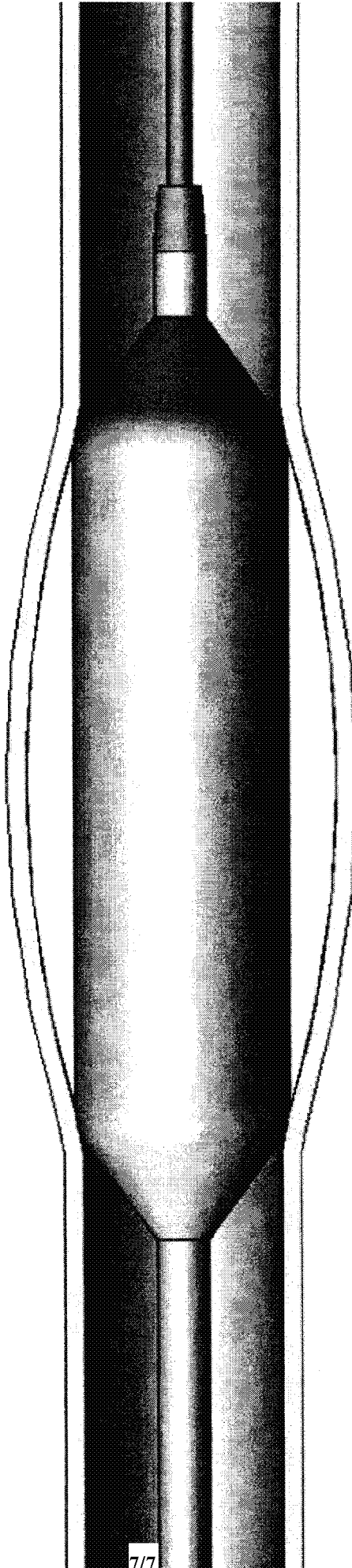

FIG. 4C

INTERNATIONAL SEARCH REPORT

International application No.

PCT/IB13/00217

<p>A. CLASSIFICATION OF SUBJECT MATTER IPC(8) - A61F 2/06, 2/958 (2013.01) USPC - 623/1.1, 1.11, 1.12, 1.15, 1.16, 1.17 According to International Patent Classification (IPC) or to both national classification and IPC</p>											
<p>B. FIELDS SEARCHED</p> <p>Minimum documentation searched (classification system followed by classification symbols) IPC(8): A61F 2/06, 2/958 (2013.01) USPC: 623/1.1, 1.11, 1.12, 1.15, 1.16, 1.17</p> <p>Documentation searched other than minimum documentation to the extent that such documents are included in the fields searched</p> <p>Electronic data base consulted during the international search (name of data base and, where practicable, search terms used) MicroPatent (US-G, US-A, EP-A, EP-B, WO, JP-bib, DE-C,B, DE-A, DE-T, DE-U, GB-A, FR-A); DialogPRO; Google; Google Scholar; Elsevier/Pubmed: balloon, inflatable, catheter, tube, line, pipe, selectable, choose, pick, indicate, decide, inflatable, expand, fill, increase, swell, distend, bloat, portion, fraction, percentage, part, segment, section, division</p>											
<p>C. DOCUMENTS CONSIDERED TO BE RELEVANT</p> <table border="1"> <thead> <tr> <th>Category*</th> <th>Citation of document, with indication, where appropriate, of the relevant passages</th> <th>Relevant to claim No.</th> </tr> </thead> <tbody> <tr> <td>X — Y</td> <td>WO 2011/112863 A1 (KONSTANTINO, E et al.) September 15, 2011; figures 2B2, 3B, 4A, 4B; paragraphs [0008], [0025]-[0026], [0028]-[0030], [0033], [0035], [0038]</td> <td>1-6, 8-15 ----- 7</td> </tr> <tr> <td>Y</td> <td>US 2011/0071616 A1 (CLARKE, G et al.) March 24, 2011; figure 5; paragraph [0037]</td> <td>7</td> </tr> </tbody> </table>			Category*	Citation of document, with indication, where appropriate, of the relevant passages	Relevant to claim No.	X — Y	WO 2011/112863 A1 (KONSTANTINO, E et al.) September 15, 2011; figures 2B2, 3B, 4A, 4B; paragraphs [0008], [0025]-[0026], [0028]-[0030], [0033], [0035], [0038]	1-6, 8-15 ----- 7	Y	US 2011/0071616 A1 (CLARKE, G et al.) March 24, 2011; figure 5; paragraph [0037]	7
Category*	Citation of document, with indication, where appropriate, of the relevant passages	Relevant to claim No.									
X — Y	WO 2011/112863 A1 (KONSTANTINO, E et al.) September 15, 2011; figures 2B2, 3B, 4A, 4B; paragraphs [0008], [0025]-[0026], [0028]-[0030], [0033], [0035], [0038]	1-6, 8-15 ----- 7									
Y	US 2011/0071616 A1 (CLARKE, G et al.) March 24, 2011; figure 5; paragraph [0037]	7									
<p><input type="checkbox"/> Further documents are listed in the continuation of Box C. <input type="checkbox"/></p>											
<p>* Special categories of cited documents:</p> <p>"A" document defining the general state of the art which is not considered to be of particular relevance</p> <p>"E" earlier application or patent but published on or after the international filing date</p> <p>"L" document which may throw doubts on priority claim(s) or which is cited to establish the publication date of another citation or other special reason (as specified)</p> <p>"O" document referring to an oral disclosure, use, exhibition or other means</p> <p>"P" document published prior to the international filing date but later than the priority date claimed</p> <p>"T" later document published after the international filing date or priority date and not in conflict with the application but cited to understand the principle or theory underlying the invention</p> <p>"X" document of particular relevance; the claimed invention cannot be considered novel or cannot be considered to involve an inventive step when the document is taken alone</p> <p>"Y" document of particular relevance; the claimed invention cannot be considered to involve an inventive step when the document is combined with one or more other such documents, such combination being obvious to a person skilled in the art</p> <p>"&" document member of the same patent family</p>											
<p>Date of the actual completion of the international search</p> <p>28 May 2013 (28.05.2013)</p>		<p>Date of mailing of the international search report</p> <p>14 JUN 2013</p>									
<p>Name and mailing address of the ISA/US</p> <p>Mail Stop PCT, Attn: ISA/US, Commissioner for Patents P.O. Box 1450, Alexandria, Virginia 22313-1450 Facsimile No. 571-273-3201</p>		<p>Authorized officer:</p> <p>Shane Thomas</p> <p>PCT Helpdesk: 571-272-4300 PCT OSP: 571-272-7774</p>									