



US006616932B2

(12) **United States Patent**
Chrai et al.

(10) **Patent No.:** **US 6,616,932 B2**
(45) **Date of Patent:** ***Sep. 9, 2003**

(54) **LIQUID PHARMACEUTICAL FOR ORAL DELIVERY**

(75) Inventors: **Suggy S. Chrai**, Cranbury, NJ (US);
Ramaswamy Murari, Hillsborough, NJ (US)

(73) Assignee: **Delsys Pharmaceutical Corporation**,
Monmouth Junction, NJ (US)

(*) Notice: This patent issued on a continued prosecution application filed under 37 CFR 1.53(d), and is subject to the twenty year patent term provisions of 35 U.S.C. 154(a)(2).

Subject to any disclaimer, the term of this patent is extended or adjusted under 35 U.S.C. 154(b) by 0 days.

4,650,669 A	*	3/1987	Alexander et al.	424/44
4,786,503 A	*	11/1988	Edgren et al.	424/443
4,832,956 A	*	5/1989	Gergely et al.	424/466
4,942,039 A	*	7/1990	Duvall et al.	424/466
5,055,306 A	*	10/1991	Barry et al.	424/482
5,296,236 A	*	3/1994	Santus et al.	424/490
5,714,007 A		2/1998	Pletcher et al.	118/629
5,780,057 A	*	7/1998	Conte et al.	424/468
5,783,212 A		7/1998	Fassih et al.	424/472
6,258,823 B1	*	7/2001	Holt et al.	514/291

FOREIGN PATENT DOCUMENTS

EP	281200	9/1988
EP	584594	3/1994
EP	667115	8/1995
GB	1075470	7/1967
WO	WO 94/06416	* 3/1994

* cited by examiner

(21) Appl. No.: **09/404,412**

(22) Filed: **Sep. 23, 1999**

(65) **Prior Publication Data**

US 2003/0108601 A1 Jun. 12, 2003

Related U.S. Application Data

(60) Provisional application No. 60/101,897, filed on Sep. 25, 1998.

(51) **Int. Cl.**⁷ **A61K 9/00**; A61K 9/24

(52) **U.S. Cl.** **424/400**; 424/472

(58) **Field of Search** 424/400, 472

(56) **References Cited**

U.S. PATENT DOCUMENTS

4,128,445 A 12/1978 Sturzenegger et al. 156/64

Primary Examiner—Thurman K. Page

Assistant Examiner—Todd D Ware

(74) *Attorney, Agent, or Firm*—Elliot M. Olstein; Raymond J. Lillie

(57) **ABSTRACT**

A liquid pharmaceutical for oral delivery wherein at the time of use, a solid unit dosage form is added to the liquid wherein the unit dosage form is comprised of a substrate soluble in the liquid and a particulate pharmaceutically active material in a pharmaceutically effective amount. At the time of use, the unit dosage form is added to the liquid, without requiring measurement of the liquid, and the entire liquid is consumed to provide for oral delivery of the pharmaceutically effective amount of material.

7 Claims, 11 Drawing Sheets

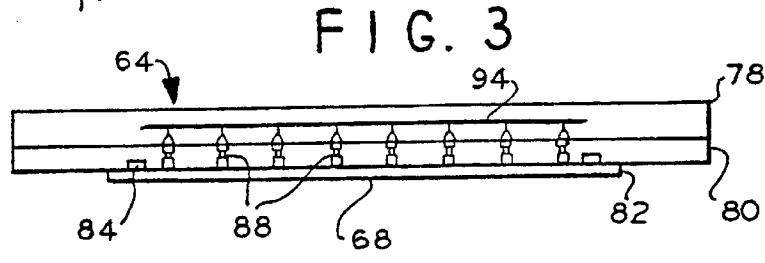
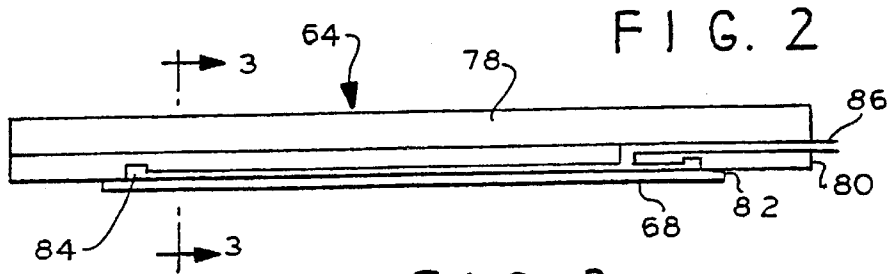

FIG. 4

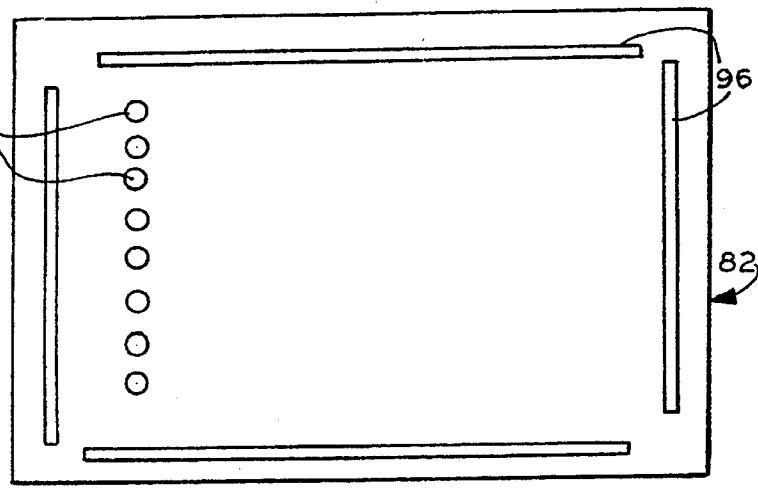

FIG. 3B

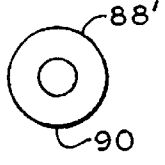

FIG. 3A

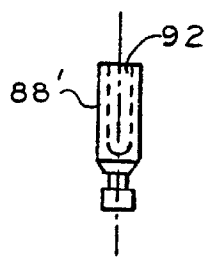

FIG. 5

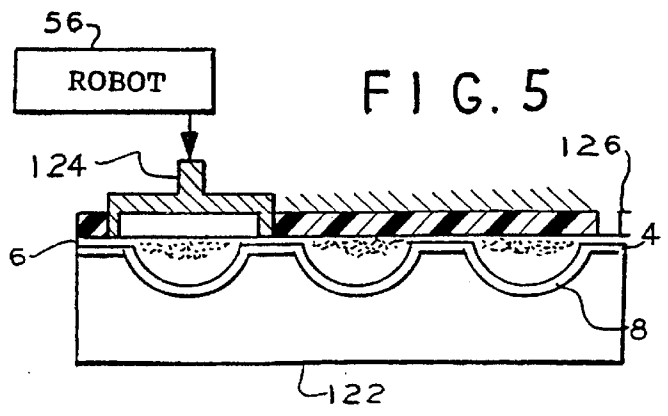

FIG. 6

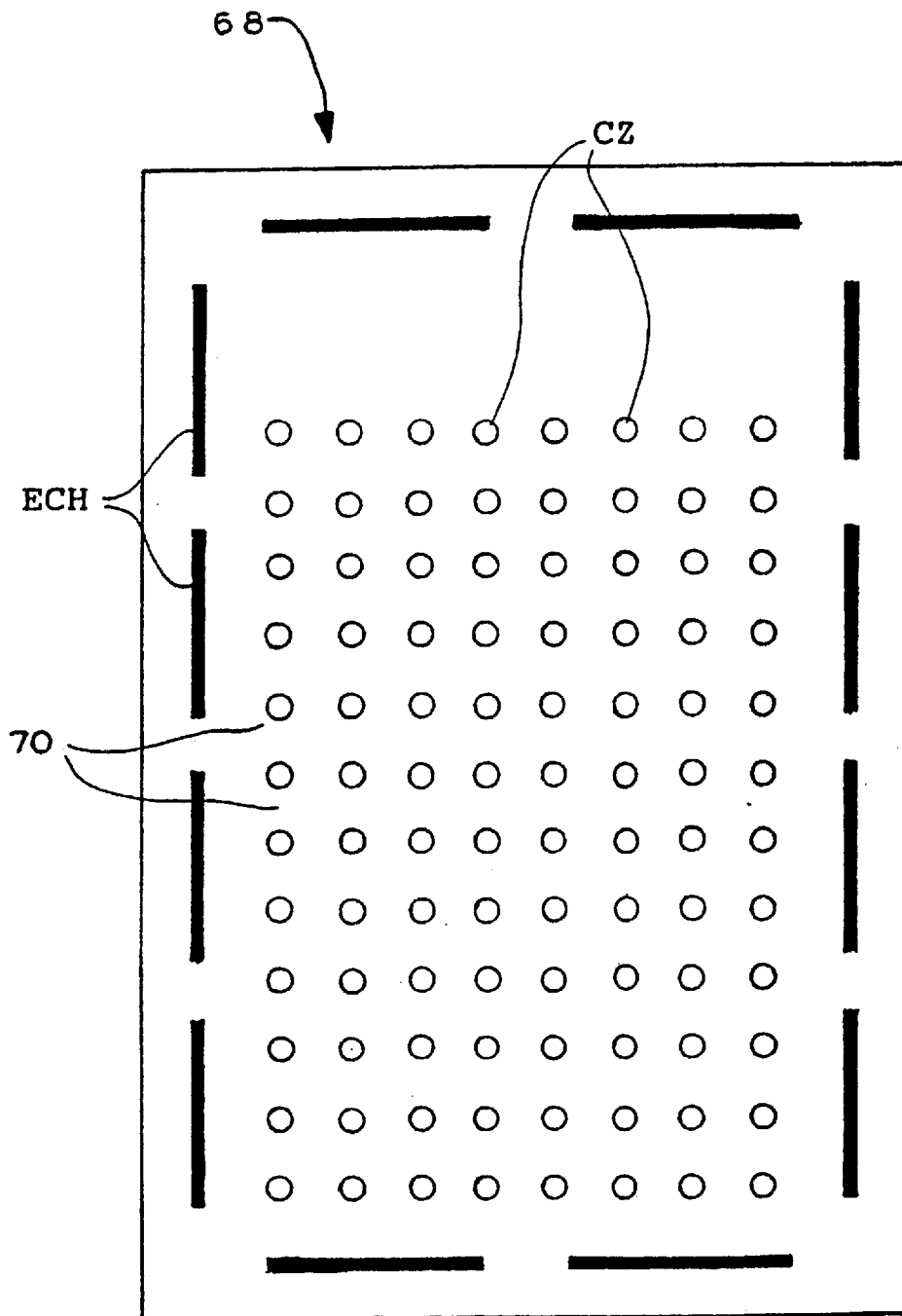
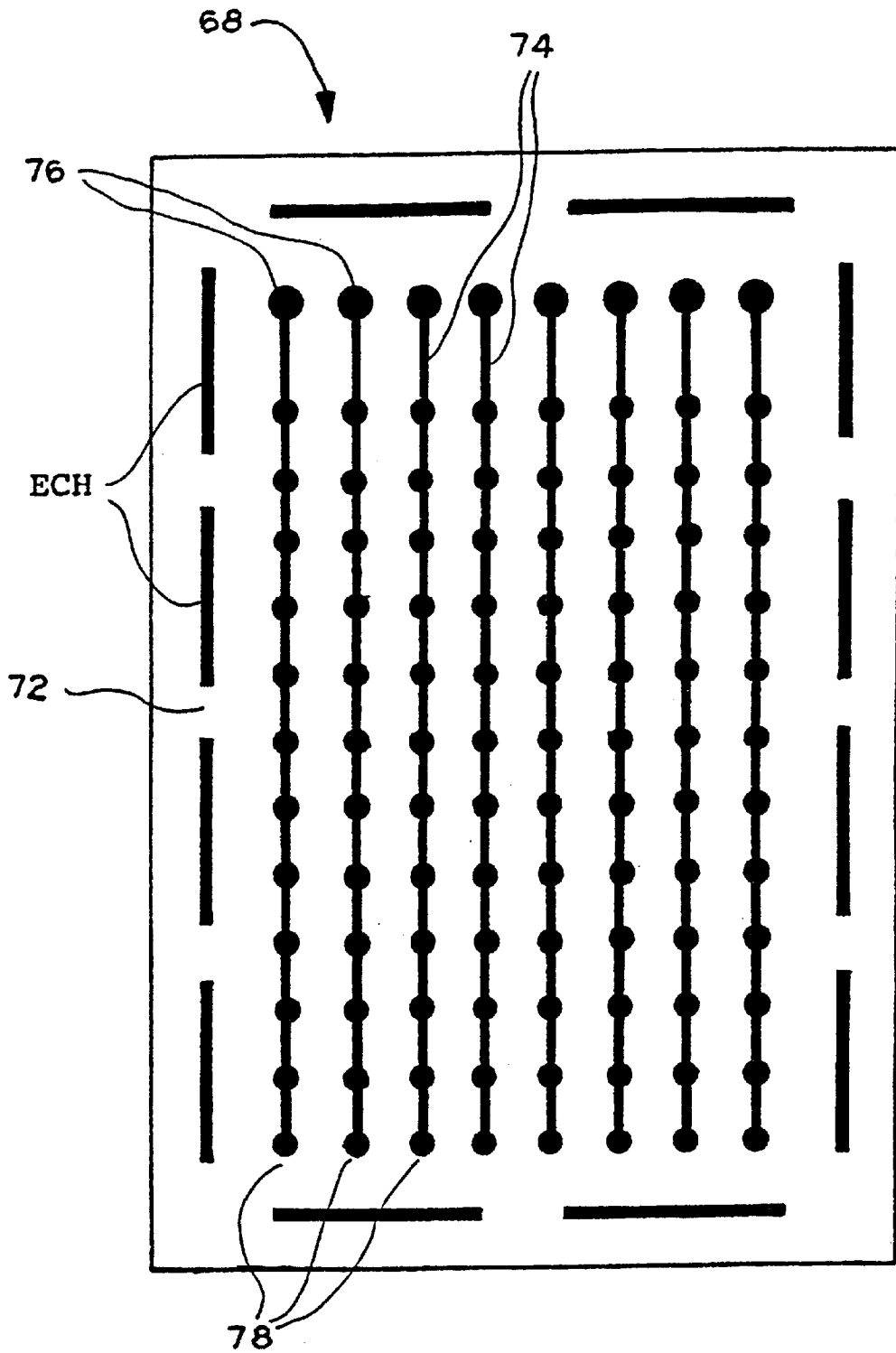

FIG. 7



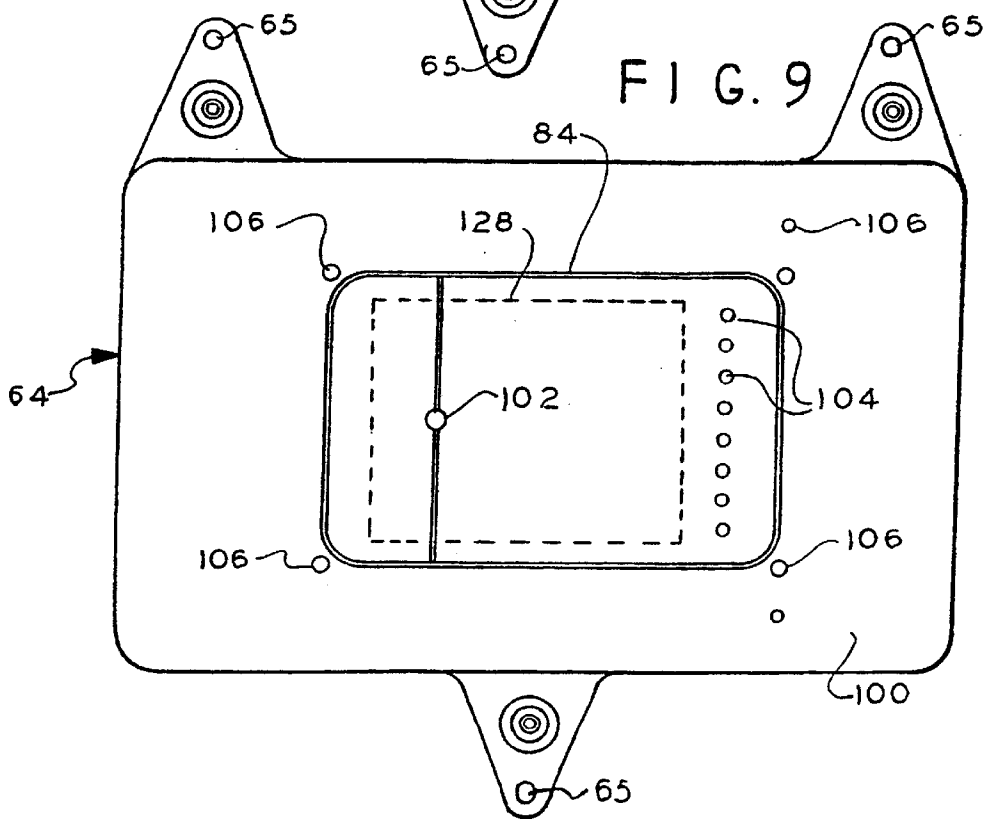
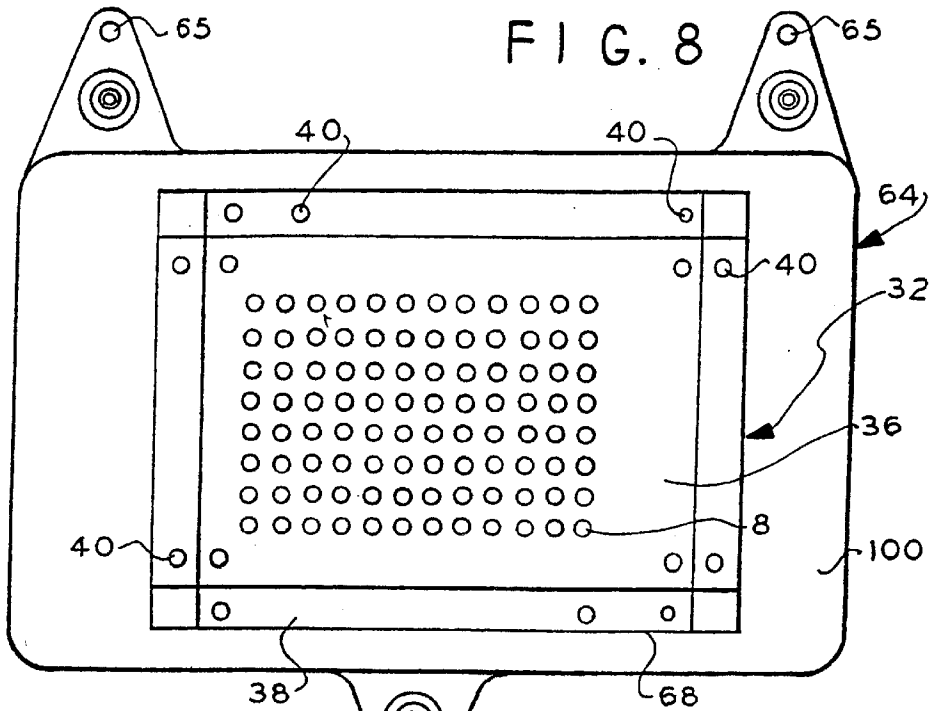

FIG. 10A

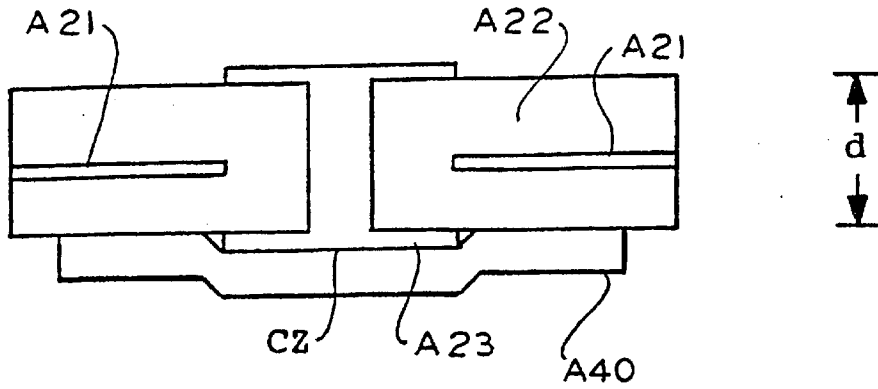

FIG. 10B

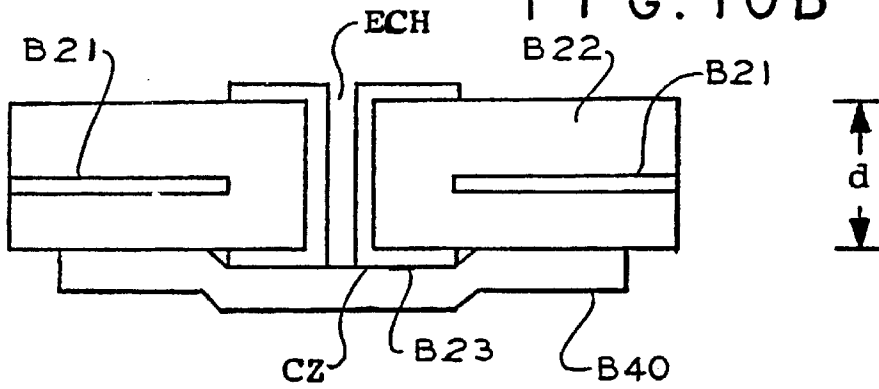

FIG. 10C

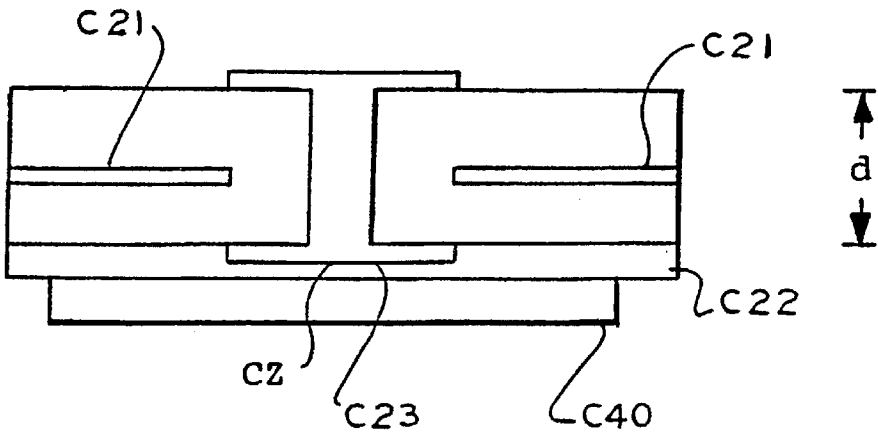

FIG. 11A

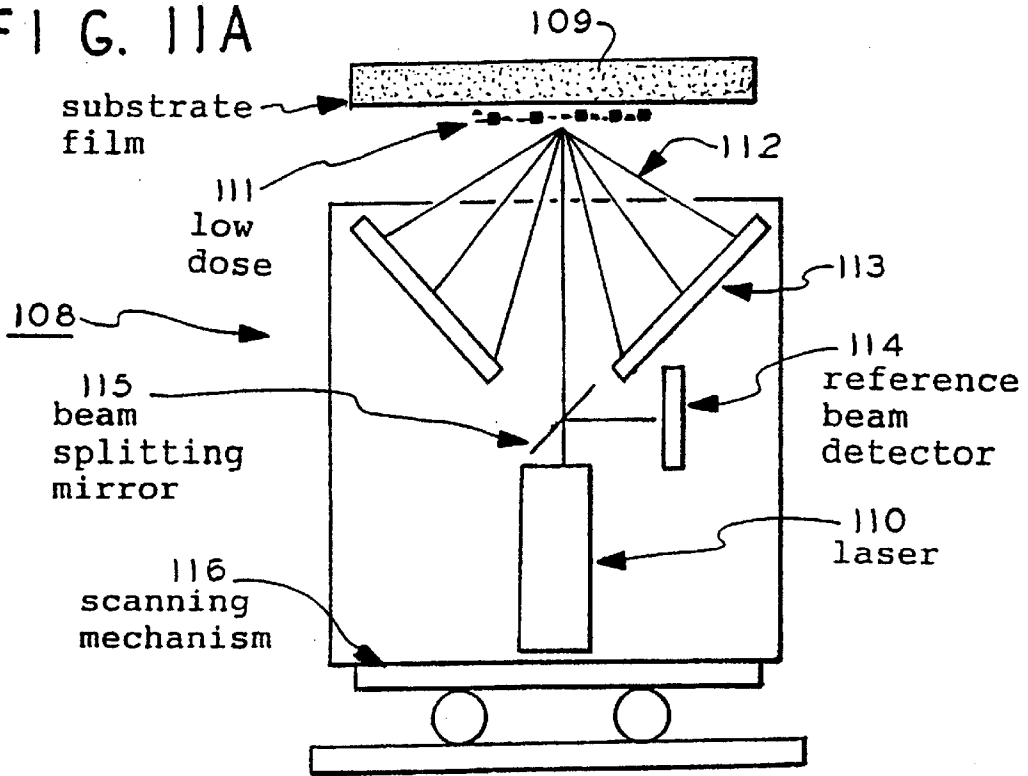

FIG. 11B

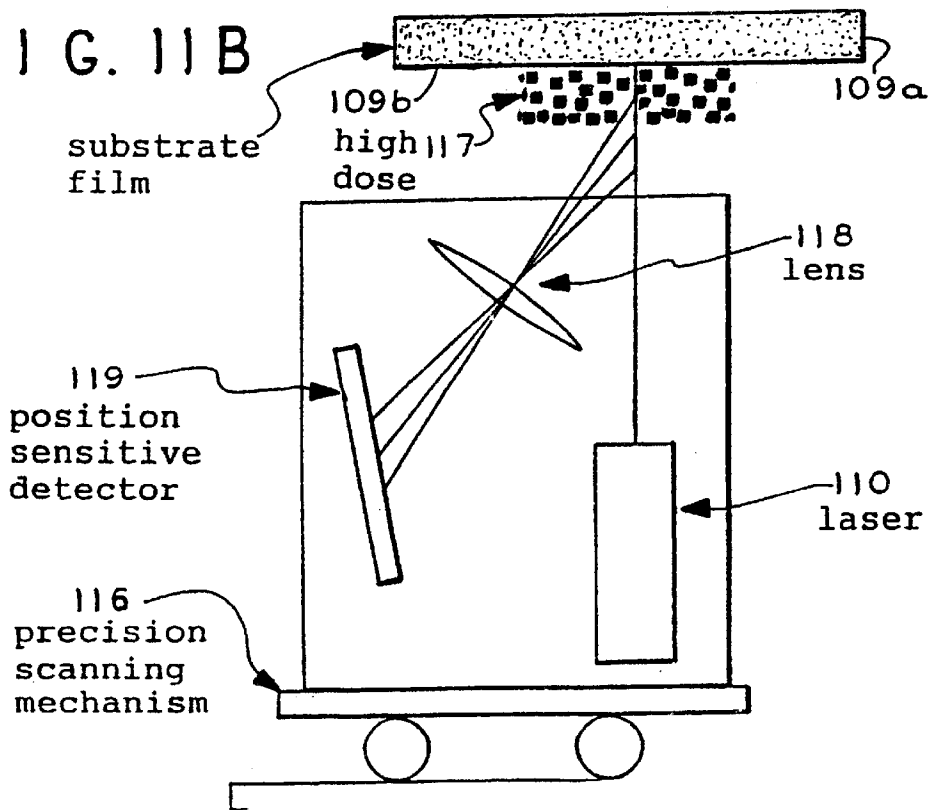

FIG. 12

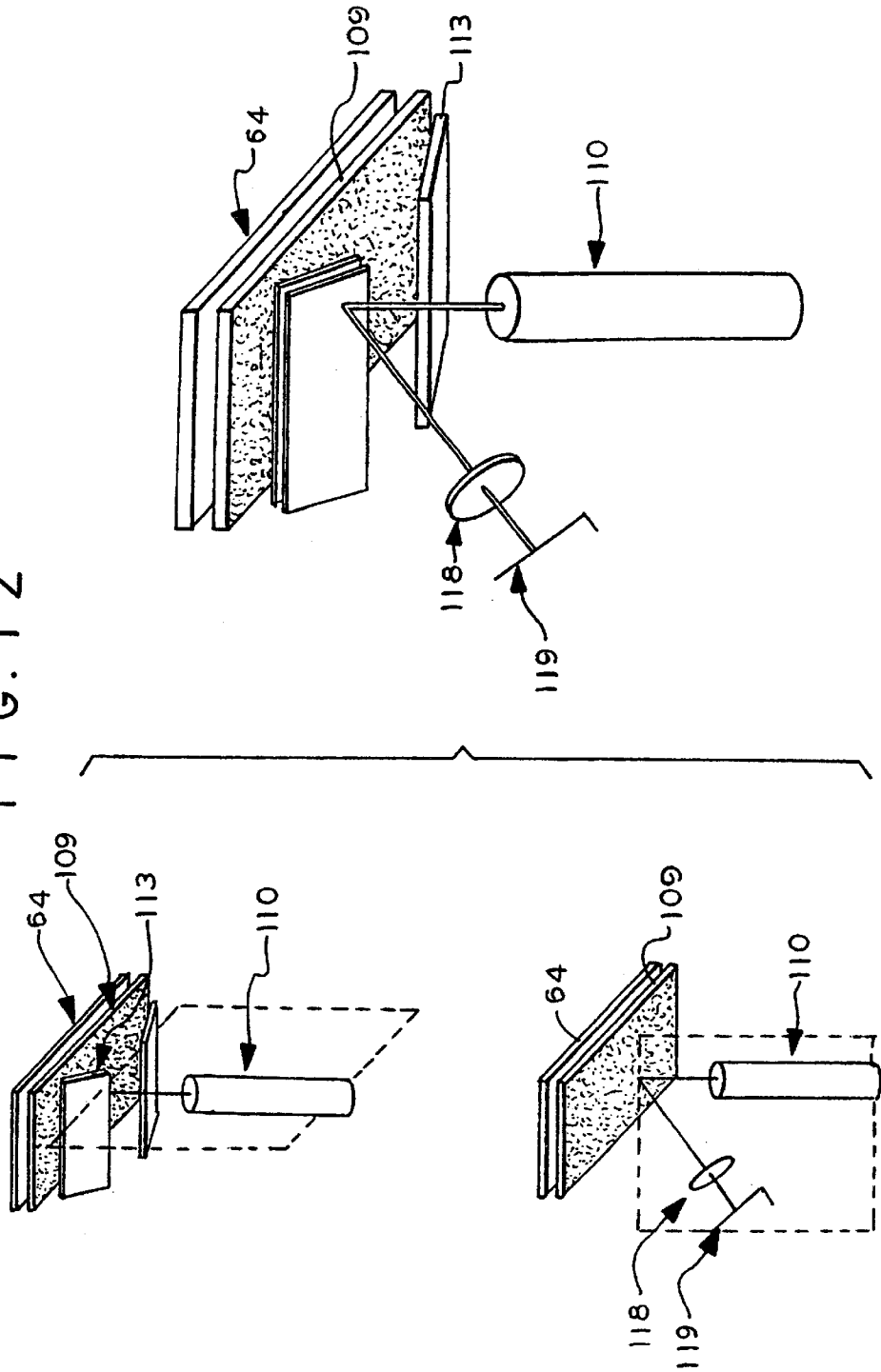

FIG. 13

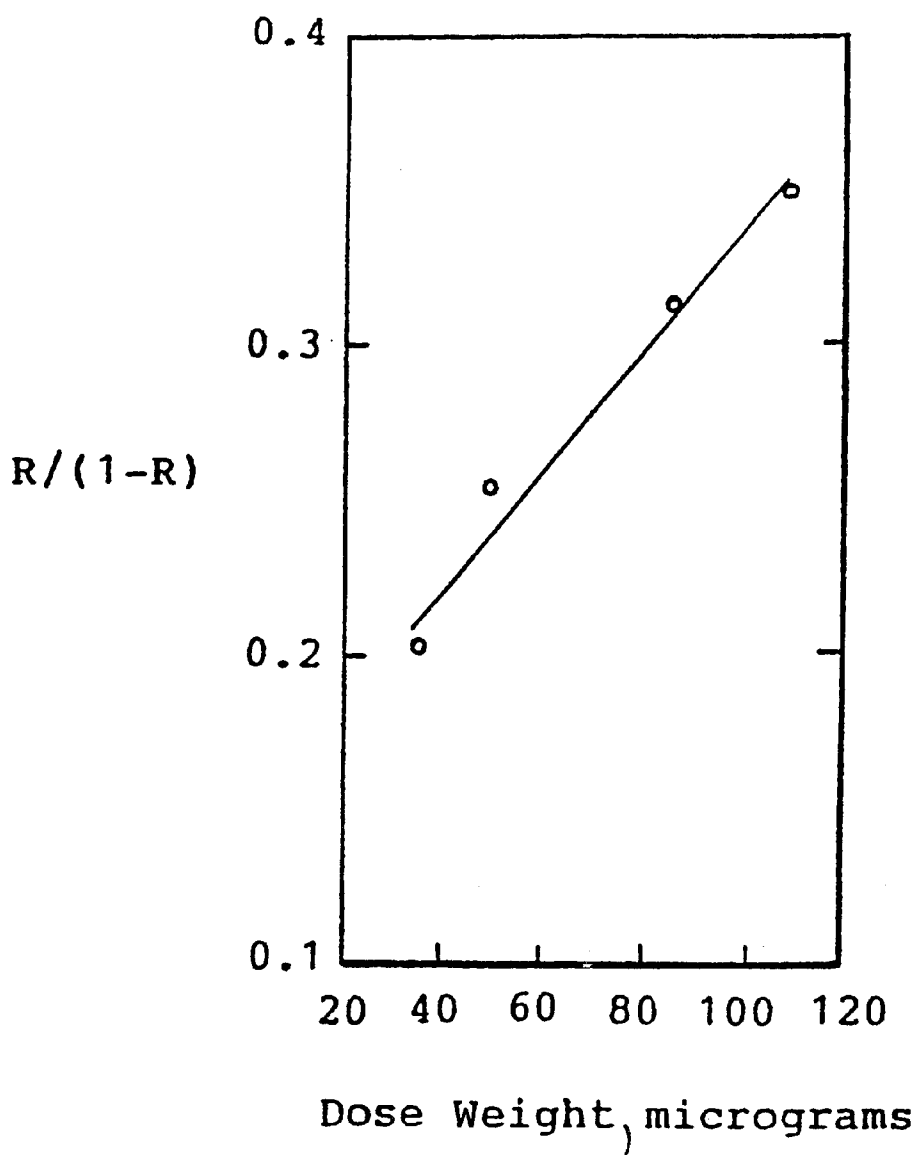

FIG. 16

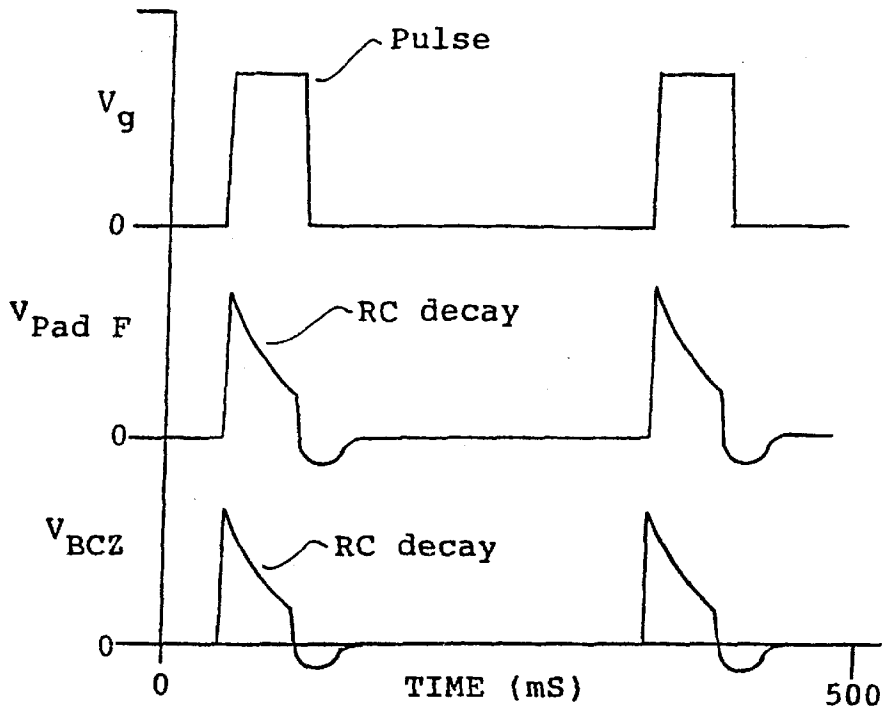
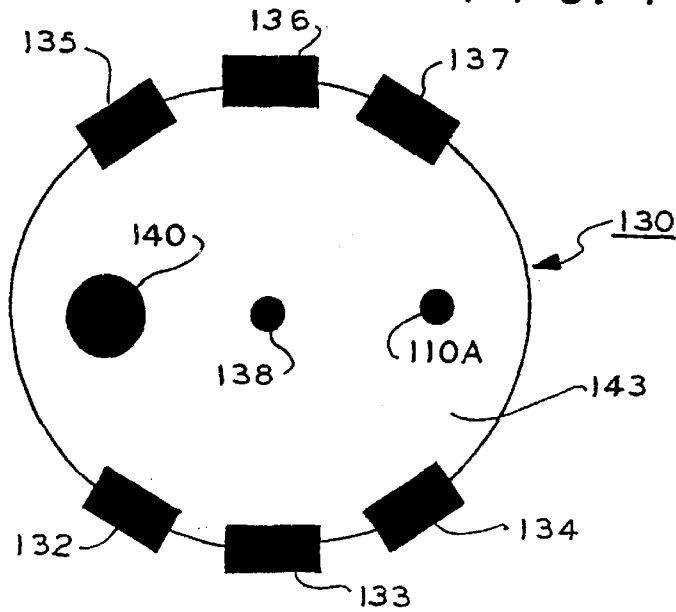
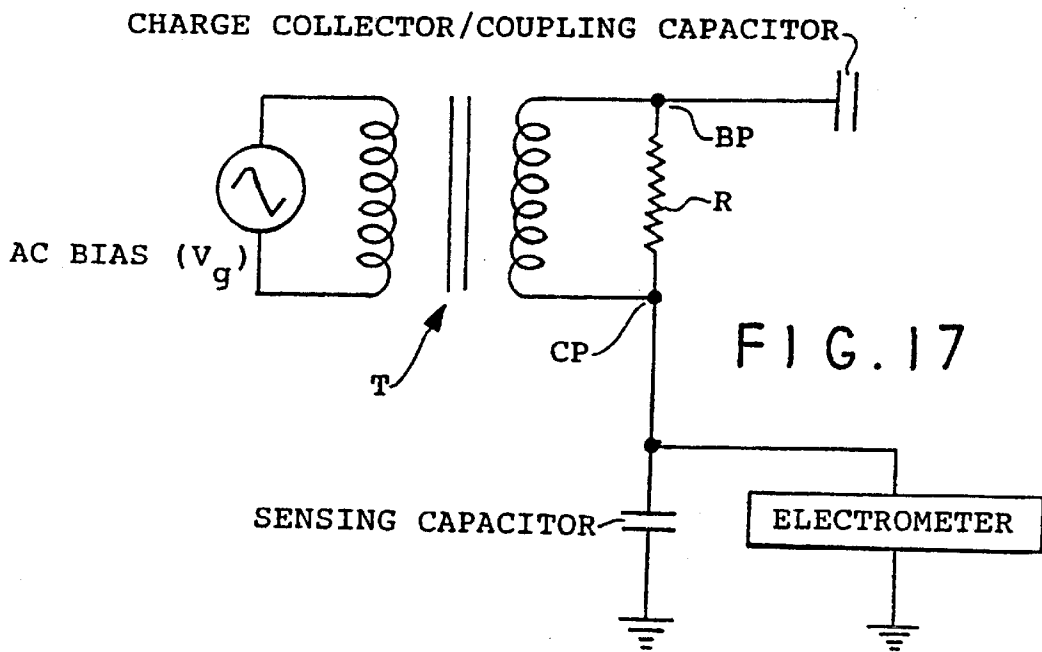
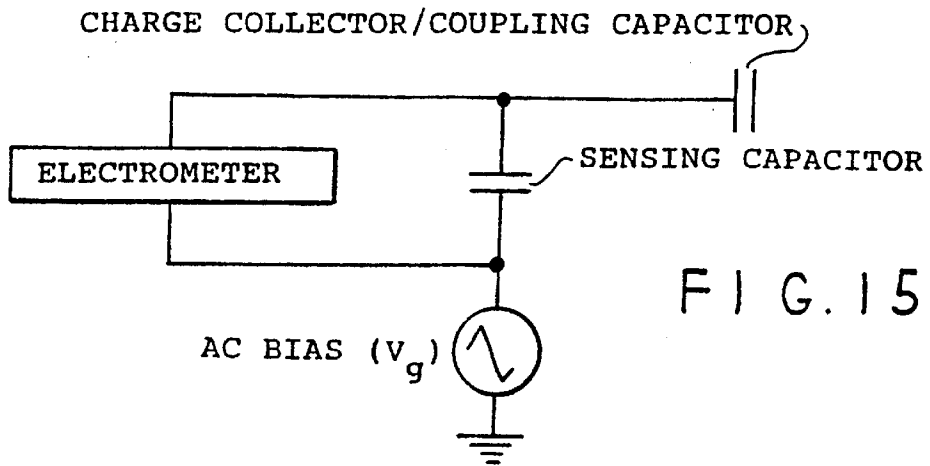

FIG. 14





LIQUID PHARMACEUTICAL FOR ORAL DELIVERY

This application claims the priority of provisional application Ser. No. 60/101,897, filed Sep. 25, 1998.

This invention relates to a liquid pharmaceutical preparation for oral delivery and to the preparation and use thereof. This invention further relates to liquid pharmaceutical preparations for oral delivery to children.

In many cases, it is desirable and/or necessary to deliver a pharmaceutical in liquid form. In general, in using such liquid pharmaceutical preparations, the pharmacist initially prepares a suspension of the pharmaceutically active material in a liquid carrier, and the suspension is placed into an appropriate container. At the time of use, the person using the preparation dispenses the liquid from the container into a spoon or dropper, which "measures" the amount of the liquid suspension for oral delivery of the suspension in the proper dosage. For example, in the case of antibiotics for oral delivery as a liquid, the antibiotic is prepared as a dry mix. When called upon to constitute and dispense such product, the pharmacist generally loosens the powder at the bottom of the container by lightly tapping it against the hard surface. However, if this is not done correctly, drug will remain as a cake at the bottom of the container, which will cause a sub-potent dose of drug to be administered to the patient. Once the drug is loosened in the container, the pharmacist proceeds to add the label designated amount to purified water. It is important that the pharmacist add the exact amount of purified water to the powder if the proper drug concentration per unit dose is to be achieved. Typically, purified water is needed to constitute current commercial dry pharmaceutical powders for oral suspension because of stability issues with tap water. In addition liquid suspension of a pharmaceutical may not be stable. This instability may occur over the typical 7-14 day shelf life of current constituted suspensions.

The thus prepared suspension contains a plurality of unit dosages, and, therefore, when being used, the person who is to take the pharmaceutical dispenses a specified amount of the liquid suspension from the container. In general, the container specifies that the unit dosage form that is to be used is a convenient measure such as 5 milliliters or one teaspoonful. However, teaspoons typically vary in volume, and to the extent that the volume of a teaspoon is inaccurate, the person dispensing or taking the liquid usually does not precisely dispense a teaspoonful.

As a result, there is a variation in the amount of drug that a patient receives that may result from the pharmacist preparing the liquid suspension or the patient dispensing an incorrect amount of the liquid suspension.

In accordance with an aspect of the present invention, there is provided a pharmaceutical composition, as well as a process for preparing a pharmaceutical composition for oral delivery in a liquid carrier that permits the formulation and dispensing of more accurate dosages of a pharmaceutically active agent or material for oral delivery in a liquid carrier.

In accordance with an embodiment of the invention, there is provided a solid unit dosage form, which at the time of use is added to a pharmaceutically acceptable liquid, such as water wherein the unit dosage form is comprised of a substrate and a particulate pharmaceutically active material deposited on such substrate with the pharmaceutically active material being present on the substrate in a pharmaceutically effective amount. The substrate is one that disintegrates rapidly in the liquid to form a solution or suspension suitable

for oral delivery in the liquid. In this manner, at the time of use, the solid unit dosage form, is added to a liquid, and the pharmaceutically active material can be orally delivered in a pharmaceutically effective dosage without measuring the quantity of liquid carrier at the time of use. Thus, the solid unit dosage form contains the required amount of pharmaceutically active material, and when it is added to liquid, the substrate disintegrates rapidly, and the particulate pharmaceutically active material is dissolved or suspended in the liquid. The liquid may include a syrup or other sweetener in order to improve the palatability of the liquid and pharmaceutically active material. The entire amount of liquid is then swallowed and since the solid dosage form contains the required amount of pharmaceutically active material, there is no need to measure the quantity of liquid in order to prepare the proper dosage. The pharmaceutically active material may be comprised of one or more pharmaceutically active agents.

In a preferred embodiment, the solid unit dosage form is one in which the pharmaceutically active agent(s) or material(s) is deposited on the substrate as a layer separate and distinct from the substrate. In a particularly preferred embodiment, the pharmaceutically active agent(s) or material(s) is deposited as a separate and distinct layer on the substrate without being blended with non-pharmaceutically active material. Thus, the pharmaceutically active agent(s) or material(s), in the solid unit dosage form, is not blended with other materials.

In another embodiment, a small quantity of one or more taste modifiers may be deposited on the substrate with pharmaceutically active agent.

The substrate is preferably soluble in a pharmaceutically acceptable liquid such as water and, more preferably, rapidly dissolves therein. As representative examples of substrates that may be used in the present invention, there may be mentioned: gelatin, hydroxypropylmethylcellulose, hydroxypropylcellulose, polyvinyl alcohol, polyethylene oxide, polyvinylpyrrolidone, sodium alginate, carboxymethylcellulose, and agar. It is to be understood, however, that the scope of the invention is not limited to such substrates.

Thus, in accordance with an aspect of the present invention, there is provided a pharmaceutical composition that is a solid unit dosage form that is comprised of a substrate rapidly soluble in a pharmaceutically acceptable liquid such as water and a particulate pharmaceutically active material deposited on the substrate as a separate and distinct layer, wherein the pharmaceutically active material is present in a desired unit dosage amount, whereby the unit dosage form can be added to liquid, at the time of use, for oral delivery of the pharmaceutically active material in a liquid carrier.

In accordance with another aspect, the pharmaceutical composition is one which is for administration to children patients; i.e., patients no older than twelve years, wherein the amount of pharmaceutically active material present in the solid unit dosage form is both a pharmaceutically effective unit dosage amount and an amount suitable for administration to children.

In accordance with another aspect, the pharmaceutical composition is one which is for administration to geriatric patients; i.e., patients older than seventy years, wherein the amount of pharmaceutically active material present in the solid unit dosage form is both a pharmaceutically effective unit dosage amount and an amount suitable for administration to geriatric patients.

The invention is particularly applicable to the delivery of antibiotic and/or anti-viral and/or anti-fungal and/or anti-

infective agents; however, the scope of the invention is not limited thereto. In a particularly preferred embodiment, the invention is directed to delivery of an antibiotic to children, wherein the unit dosage form contains a pharmaceutically effective amount of the antibiotic that is suitable for administration to children.

In accordance with a preferred embodiment of the present invention, a solid unit dosage form, which is to be added to a pharmaceutically acceptable liquid, such as water, for oral delivery in accordance with the present invention is preferably prepared by a process wherein the active ingredient is directly deposited onto an appropriate substrate, preferably by electrostatic deposition. Thus, for example, the pharmaceutically active material is electrostatically deposited onto substrate, which preferably dissolves rapidly in a pharmaceutically acceptable liquid such as water. In a preferred embodiment, a cover sheet of material identical or similar to the substrate may be placed over the pharmaceutical reagent on the substrate and sealed to the substrate. In an alternative embodiment, if a cover sheet is not used, the substrate can be rolled into a final dosage form.

The drug or pharmaceutical deposited onto the substrate may be further processed to yield a finished dosage form of a given shape or size.

At the time of use, the solid unit dosage form is added to a liquid, such as water, and in view of the fact that the solid unit dosage form contains the required amount of pharmaceutically active material(s), the patient receives an accurate dosage provided that all of the liquid to which the material is added is consumed, and such accurate dosage is obtained without necessitating the measurement of a controlled amount of liquid for forming the liquid pharmaceutical preparation. In accordance with an embodiment of the invention, a plurality of solid unit dosage forms are placed in an appropriate package; for example, a container, blister pack, etc., along with instructions that at the time of use, the unit dosage form is to be added to a liquid, such as water, and the contents swallowed.

In accordance with a preferred embodiment of the present invention, the solid unit dosage forms of the present invention are included in a package that contains a plurality of such unit dosage forms, and each of the unit dosage forms does not vary from a predetermined amount by more than about 5%.

As hereinabove indicated, in accordance with a preferred embodiment, the solid unit dosage forms that are to be packaged for subsequent addition to a pharmaceutically acceptable liquid, such as water, for oral delivery are produced by an electrostatic deposition process wherein the pharmaceutically active ingredient, as a powder, is applied to a suitable substrate. A preferred embodiment for producing such unit dosage form is illustrated in the accompanying drawings wherein:

BRIEF DESCRIPTION OF THE DRAWINGS

FIG. 1 is a plan schematic view of a system for making a product according to one embodiment of the present invention;

FIG. 2 is a schematic side elevation sectional view of a robotically operated electrostatic chuck for carrying a substrate forming the unit forms of an embodiment of the present invention;

FIG. 3 is a side elevation sectional view of the chuck of FIG. 2 taken along lines 2—2;

FIG. 4 is a plan view of a gasket employed in the embodiment of FIGS. 2 and 3;

FIG. 5 is a side elevation sectional schematic view of the formation of a package of the present invention at a lamination station;

FIG. 6 is a plan view of a front surface the electrostatic chuck of FIG. 2 without the gasket in place showing the surface of the chuck showing through holes and collection zones for active powder/grains;

FIG. 7 is a plan view of a rear surface of the chuck of FIG. 6 showing addressing electrodes coupled to drive electronics (not shown) for driving powder collection electrodes;

FIG. 8 is a plan view of the underside of the chuck attached to a robotically operated receiving head;

FIG. 9 is a plan view of the receiving head without the chuck installed;

FIGS. 10a, 10b and 10c are schematic sectional elevation views of different embodiments of powder/grain attracting electrodes that may be employed in the electrostatic chuck embodiment of FIGS. 2, 3, 6, 7 and 8;

FIG. 11A is a schematic illustration of a diffuse reflection system for characterizing the amount of deposited dry powders;

FIG. 11B is a schematic illustration of an optical profilometry system for characterizing the amount of deposited dry powder/grains;

FIG. 12 illustrates a substrate that can be measured with both the optical profilometry and diffusion reflection systems of FIGS. 11B and 11A respectively;

FIG. 13 is a graph useful for explaining the principles of the present invention;

FIG. 14 is schematic plan view of a detection array at the measurement station of the embodiment of FIG. 1;

FIG. 15 is a schematic circuit diagram for providing an AC bias charge and deposition sensing for a floating pad electrode;

FIG. 16 is a waveform diagram useful for explaining the principles of the diagram of FIG. 15; and

FIG. 17 is a schematic circuit diagram for providing an alternative AC bias charge and deposition sensing.

Referring to the drawings, in FIG. 1, system 24 for fabricating the unit pharmaceutical or diagnostic dosage forms 5 comprises a robotic platform 26 in which the product forms 5 are created in which dry powder/grains are deposited on the substrates. The platform 26 is in an environmental enclosure comprising thermoplastic, e.g., acrylic, sheet walls 28 and including a ceiling (not shown). The platform 26 comprises substrate input/output stations 30a, 30b and 30c at which framed substrate assemblies 32 and 34 are stored for later use or processing. The platform 26 includes alignment station 44, measurement station 48 employing dose measurement apparatus 50, deposition station 52, and lamination station 54.

The framed substrate assembly 32 at stations 30b and 30c comprises a rectangular cover substrate 36 having an eight by twelve array of depressions 8, for example. Assembly 32 includes a metal frame (not shown), e.g., sheet aluminum, to which the substrate is secured. The frame includes guide holes (not shown). The guide holes mate with guide pins (not shown) at the input/output stations 30b and 30c, FIG. 1a, the robot head (not shown) of robot 56 at lamination station 54. The substrates 36 form the cover 4, FIG. 1.

The substrates 34 at station 30a each form the base 6 FIG. 1. The substrate of assembly 34 differs from the substrate 36 in that no depressions are formed in the substrate of assembly 34. The substrate of assembly 34 is also attached to a

frame such as frame 38. The frames via their guide holes mate in guide pins (not shown) at the input/output station 30a and the alignment station 44 which aligns the frames 38 to the robot head of robot 46 at the measurement station 48.

Alignment station 44 aligns the substrate assembly 34 to its mating pick up robot 46 located at measurement station 48 for providing accurate processing of the deposition powder/grains on the substrate of assembly 34. Measurement station 48 includes a dose measurement apparatus 50 having a measurement window (e.g., glass-not shown). The platform 26 includes a powder/grain deposition station 52 and a lamination station 54 at which is located a second robot 56. The robot 46 picks up and transports the base 6 substrate assemblies 34 and the robot 56 picks up and transports the cover 4 substrate assemblies 32 from the corresponding input/output stations.

Charged powder/grains are delivered to the robotic platform deposition station 52 from powder/grain feed apparatus 60, which also is in an environmentally controlled enclosure. Environment control 62 controls the environment of the platform 25 and apparatus 60 by controlling temperature, pressure and humidity. Computer and controller 62 operates the powder/grain feed apparatus, the robots of the platform 26 and the measurements made at station 48 by apparatus 50.

The deposition station 52 includes a deposition gasket 67 surrounding a deposition chamber 69 having an opening through which charged powder/grains are forced to flow during deposition onto the overlying substrate of assembly 34.

The robots of platform 26 can be based, for example, on a Yaskawa RobotWorld linear Motor Robot. The robots are linked to rails (not shown) for providing x-y movement via x-y linear stepper motors (not shown). Each robot has telescoping components under servo control (not shown) for moving a substrate receiver attached to its head (not shown) in the z axis normal to the x-y plane. Robot 46 has a receiver head 64, FIGS. 2, 3, 8 and 9 to which an electrostatic chuck 68, FIGS. 2 and 3, is attached. Robot 56 has an ultrasonic weld unit attached to its head for laminating the cover 4 and base 6 substrates at the lamination station 54.

Also, the robots 46 and 56 have control components to provide servo control to rotate the respective robotic head and receiver, such as receiver 64 in the x-y plane. Compressed air or other gases at a flow rate of 8 SCFM at 80 psi operate the robotic heads.

Receiver 64 is mounted with an electrostatic-vacuum chuck 68 as described, by way of example, in the aforementioned application "Apparatus for Clamping a Planar Substrate", Ser. No. 09/095,321. Vacuum lines, power lines and sensor monitoring lines (not shown) are mounted to the receiver 64 to provide operating resources for the chuck. Where substantial number of lines are to be fixed to the receiver 64, the robots are selected or modified to accommodate the additional weight.

The platform 26 is framed by supports 66 to which the walls 28 are secured. The atmosphere within the platform 26 may be air or an inert gas.

The receiver 64 has circuitry which controls and operates the chuck 68. FIG. 6 shows the upper surface of electrostatic chuck 68 with through spaced holes ECH that are either slots or linear arrays of small apertures that mimic a slot. The holes ECH extend about the periphery of the chuck 68 in spaced arrays as shown. Other configurations for the through holes ECH are illustrated in the aforementioned application Ser. No. 09/095,321. Powder/grain collection zones CZ

formed by electrodes are located on surface 70 otherwise composed of dielectric material.

FIG. 7 illustrates a rear surface 72 of the chuck 68 which has addressing electrodes 74 through which each row of the electrodes forming the collection zones CZ can be connected by driving electronics (not shown). Electrical contact pads 76 provide contact points for connections to voltage sources for controlling the amount of powder/grains deposited at each collection zone CZ.

The pads 76 and collection zones CZ (FIG. 6) connected by the electrodes 74 are arranged in eight columns 78 of 12 collection zones each, for example, each collection zone corresponding to a deposition location on the base substrate 6 (FIG. 1). Each contact 76 can receive a voltage independently of the voltage of the other contacts to separately control the amount of powder/grains deposited on the collection zones of a given column. The addressing electrodes can be arranged in different patterns to allow different control patterns. The voltage on each contact creates an electrostatic field at the corresponding electrodes at the collection zones CZ. This field attracts the powder/grains of active ingredient to the associated base substrate 6 and also holds the substrate 6 flat against the chuck.

FIGS. 10A-10C illustrate features of electrostatic chucks at a collection zone CZ that can be employed in the present invention. In FIG. 10A, a shield electrode A21 (also termed a "ground electrode" based on a preferred bias) is layered with a dielectric A22 which dielectric can comprise, for example, Kapton, a registered trademark of DuPont de Nemours for a polyamide film. Kapton material can be etched, punched and laser drilled and used to form multi-layer polyamide film laminates.

The powder/grain-attracting electrode A23 projects out at the surface that attracts the planar substrate A40, for example 0.001 inches thick (0.0254 mm), and can project out at the opposing side where electrical contacts are formed. The width d of the film dielectric A22 forming the chuck can be 0.01 inches (0.254 mm) for example. This makes the chuck 68 relatively flexible. The planar substrate A40 wraps over the outwardly projecting powder/grain-attracting electrode A23 in relatively close fitting relationship. This is most effective when a vacuum chuck is used in conjunction with the electrostatic chuck. That is, a vacuum is applied directly to the substrate via apertures (not shown) in the chuck to hold the substrate flat against the chuck. As described, the grain attracting electrodes play a role in adhering the planar substrate to the chuck. Tight adherence of the planar substrate to the electrostatic chuck increases the reliability of powder/grain deposition at the collection zones.

FIG. 10B illustrates an embodiment where the through holes ECH are formed at the powder/grain-attracting electrode A23. FIG. 10C illustrates an embodiment where an additional layer of dielectric C22 separates the powder/grain-attracting electrode C23 from the planar substrate C40. The chuck of FIG. 10C can be termed a "Pad Indent Chuck" which is useful, for example, for depositions of less than about 100 mg per collection zone CZ (assuming a collection zone of about 4 mm diameter). The electrostatic chuck provided by the configuration of FIG. 10A can be termed a "Pad Forward Chuck" which is useful, for example, for deposition so more than about 20 mg per collection zone CZ, assuming a collection zone of about 4 mm diameter, but which is more useful for higher dose depositions than the Pad indent Chuck.

In FIG. 2, the receiver 64 preferably comprises an electronics housing 78, a vacuum manifold housing 80, and a

gasket 82. The chuck 68 is preferably aligned with the receiver 64 with locating pins and alignment holes. The vacuum manifold housing 80 has passageways 84 which convey reduced pressure to the through holes ECH (FIG. 11) in chuck 68. Reduced pressure is applied to the passageways 84 via inlet fitting 86, and via passageway outlet (not shown). Because the chuck 68 is flexible, and therefore, susceptible to deformation, and because it can be important to deposit powder/grains on a flat surface, a mechanism is provided to couple the powder/grain attracting electrodes to a voltage source without applying significant distortion pressure to the chuck 68.

Coupled pins 88 provide this mechanism. Lower pin assemblies 88', FIG. 3a, of the coupled pins 88 are inserted through holes in electronic housing 78, the vacuum manifold housing 80, and gasket 82, with a conductive adhesive, such as silver epoxy, on the lower part of the lower pin assemblies 88', FIG. 3a. The lower pin assemblies 88' have a notch 90, FIG. 3b, to allow excess adhesive to relocate in the holes. The adhesive adheres the lower pin assemblies 88' to the electrical contact pads 76, FIG. 7. The upper parts of the coupled pins 88 are standard circuit board pins, which couple with slots (not shown) on pin connector board 94, FIG. 3.

Gasket 82, FIG. 4, has slot holes 96 which allow reduced pressure (e.g., vacuum) to be transmitted to the electrostatic chuck 68 through holes ECH, FIG. 6. Another set of conduit holes 98 allow the coupled pins 88 to be inserted through the gasket 82. The gasket 82 insulates preferably at least about 2000–2500 volts and in one embodiment is coated on both sides with an adhesive. A graphics art paper meeting these requirements, which is of 0.004 inches thickness (0.1 mm) and coated on both sides with an aggressive rubber-based adhesive is available from Cello-Tak, Island Park, N.Y.

The receiver 64 may be manufactured from a durable non-conductive material such as a Noryl polymer (A registered trademark of GE). Noryl engineered plastics are modified polyphenylene oxide, or polyphenylene oxide and polyphenylene ether, resins. The material is modified by blending with a second polymer such as polystyrene or polystyrene/butadiene. A variety of grades are produced by varying the blend ratio and other additives. The material exhibits strong intermolecular attraction with extreme stiffness and lack of mobility. The Noryl based support provides firm support for maintaining a flat surface collection zone CZ containing surface of the electrostatic chuck 68 while the low weight reduces the burden on the robotic heads of robots 46 and 56 (FIG. 1a). The surface of the receiver 64 on which the electrostatic chuck 68 is mounted is preferably flat to +/-0.001 inches for example.

The frame 38, FIG. 8, for the substrate is employed for securing the substrate aligned to the various stations and robotic heads of the system. The frame is also used to hold the substrate to the chuck 68 via the chuck vacuum holes ECH, FIG. 6. The vacuum releasably secures the frame 38 to the chuck by the applied vacuum from the receiver 64. The frame 38 is preferably aluminum. The frame may be about 200 mm by 300 mm with sides having 12.7 mm width. Vacuum cup receiving fixtures on the frame 38, height adjustable vacuum cups (not shown) and vacuum fittings (not shown) on the receiver 64 may also be employed to hold the frame to the chuck.

FIG. 8 shows the chuck 68 adhered to the underside 100 of the receiver 64. Electrostatic chuck 68 has alignment mechanisms 40 which may comprise pins or holes for aligning the chuck to the receiver 64 with mating pins or

holes. In FIG. 9, receiver underside 100 is shown without the chuck 68, showing passageways 84 and outlet 102 along with pin 88 conduits 104. Alignment mechanisms 106 are shown and can be pins or holes which mate with holes or pins in the chuck 68.

Electronic control is integrated in the dry powder/grain deposition apparatus 60. This control is coupled to a processor board (not shown) in the receiver which functions as a communication board. This board receives commands from the central processor in controller 62 (FIG. 1) and relays these commands to an addressing circuit board (not shown) in the receiver 64. Also, in some embodiments, an embedded processor circuit board (not shown) in the receiver 64 receives data from sensors positioned on or adjacent to the electrostatic chuck 68 and interprets locally any adjustments to the voltages applied to the powder/grain attracting electrodes A23–C23 (FIGS. 10A–10C) that are appropriate in view of this data. These sensors are described below.

The addressing board, after receiving signals from an on-board processor board (not shown) on the receiver 64) sends bias control signals, DC or AC, e.g., about 2000 V at low current, for controlling the voltage at the electrodes 76, FIG. 7. This thus applies the voltage to the powder/grain-attracting electrodes A23–C23, FIGS. 10A–10C, in individual columns 78 or rows of electrodes or individual rows of electrodes according to a given implementation. In FIG. 7, the addressing electrodes 74 allow control individual columns of powder/grain-attracting electrodes at the collection zones CZ, FIG. 6.

The bias signals from the addressing board can be used to separate columns or rows of powder/grain attracting electrodes, or to individual powder/grain attracting electrodes. Such adjustment can be made, for example, where sensors as described below, or data from the dose measurement station 50 based on a previous deposition, indicate that an uneven distribution of deposition amounts is occurring. As a result, the voltages at the collection zones CZ may be advantageously increased or decreased accordingly.

The chuck 68 of FIGS. 6 and 7 has addressing electrodes 76 that allow control of individual columns of powder/grain attracting electrodes A23–C23 (FIGS. 10A–10C). Electrical signals manifesting control patterns that control regions or individual collection zones CZ can also be used.

The addressing board preferably has multiple channels of synchronized output signals, e.g., square wave or DC. These signals may be encoded with square wave pulses of varying magnitudes to identify the powder/grain-attracting electrodes or group of electrodes together with the appropriate voltage to be applied for controlling the amount of powder/grains to be deposited. The bias control signals are sent via a high voltage board (not shown) in the receiver 64 which has multiple channels of high voltage converters (transformers or HV DC-to-DC converters) for creating the deposition control voltages, such as 200 V or 2,500 V or 3,000 V (of either polarity), for operating the powder/grain-attracting electrodes. By forming the higher voltages within the receiver 64, these high voltages can be isolated from other systems.

The central processor unit controller 62, FIG. 1, receives performance input from multiple sources. This input provides data on the rate of particle flux into and through the deposition engine comprising feed apparatus 60 (FIG. 1) and deposition station 52, how evenly particles are being deposited at the chuck 68 and how well previous depositions have met the required thickness values. Various parameters of the

system may be adjusted in view of this data, including voltages at various locations on the chuck to improve performance. The on-board electronics at the receiver 64 provides the means to make these adjustments on-the-fly to be conveyed to the powder/grain attracting electrodes 74, FIG. 7.

A charge sensor 128, FIG. 9, is on the receiver 64 for sensing the amount of charge on the powder/grains attracted to the electrodes A23–C23. The sensor 128, which is schematically represented by the dashed lines, monitors the amount of powder/grains deposited, and is described in detail in the copending application Ser. No. 09/095,425 noted in the introductory portion. This application describes the use of pulsed (AC) electrical potential waveforms for biasing an electrostatic chuck to collect powder/grains such as on a substrate. This biasing overcomes the problem of collecting the powder/grains on a conductive substrate, where the powder/grain-attracting field can decay rapidly after any given application of a bias potential to the electrostatic chuck.

The use of AC bias waveforms for the powder/grain attracting electrodes also solves another long-standing problem during deposition sensing. During deposition sensing, one or more collection zones are closely monitored for powder/grain accumulation to allow regulation of the deposition process, to produce, for example, precise pharmaceutical dosage or diagnostic dosage unit amounts. This monitoring can be done optically or by measuring accumulated charge using an “on-board” charge sensor at a sensor associated collection zone, which can be correlated to actual charged grain deposition by empirical data collection. In dry powder/grain deposition, for example, dose monitoring is often a difficult task, particularly for dosages below one milligram.

The difficulty is not that measuring devices are not available—modern solid state devices, although costly, can make measurements so precise that noise levels are on the order of the voltage generated by the charge of a few hundred electrons. Rather, the difficulty lies with various practical and environmental factors that deteriorate charge sensing sensitivity by two or three orders of magnitude. For quasi-static DC biased bead (deposited powder/grains) transporter chucks, on board charge sensing is particularly difficult. Data obtained by depositing on a polypropylene film substrate with different potentials indicates that the deposited dose is linearly related to the bias potential if that potential is above a certain threshold potential. Data indicates that threshold potential is about 100–200 volts DC, at least for certain transporter chucks.

In FIG. 15, one possible equivalent circuit diagram for the circuit provided by the electrostatic chuck and substrate is illustrated. The chuck and substrate corresponding to this equivalent circuit includes a planar bead electrode that is used to provide a bead attracting field. Affixed to the bottom face of the bead electrode is a planar first dielectric layer. The dielectric layer is applied to or affixed to the bead electrode in parallel using any known techniques such as laminating, powder deposition or thin film deposition. Dielectrics may include Pyrex 7740 glass (Corning Inc.) or polyamide resin of 10–20 mils thickness. A planar shield electrode is affixed to the other face of the first dielectric layer. The latter shield electrode comprises an aperture to accommodate a floating pad electrode, coplanar with and surrounded by the latter shield electrode.

The equivalent circuit provides AC biased charge and deposition sensing for at least one of the collection zones,

which zone has a floating pad electrode. The floating pad electrode is an isolated conductor which is capacitively coupled to a powder/grain attracting electrode, such that the bias to the attracting electrode indirectly creates a powder/grain attracting field emanating from the floating pad electrode. One or more collection zones are typically dedicated solely for sensing or are in general use, but closely monitored. By measuring the lowering of the attracting potential V_{cz} that occurs as charged powder/grains collect on the collection zone, a measure of deposited charge can be obtained. By knowing the average charge/mass ratio q/m of the powder/grains, the accumulated deposition mass can be measured. V_{cz} can be measured directly across a charge collector electrode, but is often preferable to measure the potential across a coupling capacitor, such as the floating pad electrode discussed above.

The coupling capacitor as embodied by a floating pad electrode described above will provide reasonably high fidelity reproduction of the potential at the collection zone CZ on the powder/grain contact surface, and in FIG. 16, the waveforms for V_{cz} and V_{Pad} show this. In either case, whether a charge collector or charge coupling capacitor is electrically connected to a separate sensing capacitor, the voltage generated across the sensing capacitor can be a reliable indicator of the potential V_{cz} .

The voltage across the sensing capacitor is measured with an electrometer, such as a Keithly model no. 614, 6512, 617, 642, 6512, or 6517A electrometer as schematically shown in the figure. Generally, the coupling capacitor is any electrode that is capacitively coupled to a collection zone on the contact surface.

A problem is that DC biasing can cause a steady drift in the reading of the potential across the sensing capacitor. This drift comes from many sources, mostly from natural leakage across the dielectric material in the sensing capacitor, and because of charge leakage in the substrate or grain composition accumulated on the chuck. Drift can also be induced by noise factors such as shot noise, Johnson (1/f) white noise, thermal noise, Galvanic noise, triboelectric noise, piezoelectric noise, amplifier noise, and electromagnetically induced noise. See ref. *The Art of Electronics*, by Paul Horowitz, Winfield Hill, 2nd Edition, Cambridge University Press, 1989, ISBN 0521370957.

If this drift is too large compared to the actual charge collected at the collection zone, the accuracy of the charge sensor as a dose or deposition measurement tool can be unacceptably low. Using AC biased waveforms as disclosed herein will minimize the creation of drift, in a manner similar to that used above for avoiding the “drift” of charge dissipation on the collection zone, allowing precise measurement of charge collected.

In FIG. 15, an AC bias source may be the same source as discussed above, with the AC bias potential applied or administered via the powder/grain attracting electrode. This in turn electrically couples to the floating pad electrode or to the collection zone, if it is connected directly to the sensing capacitor as shown.

For example, if the sensing capacitor is chosen to be 0.1 μF and the q/m of the powder/grains is 10 $\mu\text{C/g}$, a 100 Mv signal change on the charge collector/coupling capacitor corresponds to 3 mg of powder/grain in the actual deposition dose, then a 99 mg actual dose will have a detectable potential change of 3.3 Mv. With a 5% error tolerance, the corresponding background unpredictable noise contribution cannot exceed 160 μV . This is achievable with careful shielding and grounding. Preferably the charge collector is integrated with the chuck to assure a consistent correlation.

In effect, the same benefits gained by using the AC bias waveforms for V_g to avoid charge dissipation in the substrate can be used to greatly reduce drift in the charge sensing circuit

In FIG. 17, a further possible equivalent circuit provides AC biased charge and deposition sensing. This circuit reduces noise by separating the AC bias source from the electrometer, the sensing capacitor or the charge collector/coupling capacitor. All of these components have a sensitivity to noise that is critical. The AC bias source is connected to the primary of a transformer T. In this manner, only the periodic magnetic field generated by V_g (not V_o itself) is introduced into the sensitive components on the right side of the figure. The secondary winding of transformer T is connected across a stabilizing bleed resistor R, with one pole, biasing pole BP connected to the charge collector/coupling capacitor, and the other pole, at the sensing capacitor, is connected to ground. The electrometer can then measure the voltage change on the sensing capacitor with respect to ground, as shown.

These two grounding points can be combined to reduce electromagnetic noise further. The transformer can be a step-up transformer as discussed so that complex AC bias waveforms supplied here and to the grain attracting electrode can be generated at low cost.

For example, the step-up ratio can be 50. This greatly reduces drift and makes accumulated charge sensing more accurate, where previously the coupling current of 100 pico-Amperes or less made drift and noise a problem.

If desired, transformer T can be an isolation transformer, where the primary and secondary windings are separated by a Faraday cage. This can prevent coupling between the primary and secondary windings, where the primary winding acts as one capacitor plate, and the secondary as the other capacitor plate.

With this improved signal to drift ratio, the amount of charge sensed can decrease substantially. Measurements can be made using a 1000 picoF capacitor as the sensing capacitor instead of the 0.1 μ F value used previously. Also, the AC bias source, FIGS. 15 and 17, can be separate from the AC waveform bias V_g on the chuck, by delivering a separate AC bias to the charge collector/coupling capacitor directly, via a dedicated wire, electrode, bus, etc. This separate AC bias can be frequency matched or detuned with respect to V_g to insure consistent correlation of the behavior of the charge collector/coupling capacitor to actual depositions.

Overall, too, these techniques allow V_g biasing with voltage peaks much higher than previously possible. Using 8000 molecular weight polyethylene glycol as a substrate, bias peaks of 2 kV have been used. It is important also to keep in mind that any kind of powder/grain (bead) transporter chuck can be used, including those that operate with bias electrodes directly exposed to the powder/grain (bead) contact surface.

The substrate of assembly 34 must be kept flat during deposition. To do this electrostatic forces may be applied to the dielectric layer A22, for example, FIG. 10A, of the chuck to hold the substrate layer against a reference surface on the chuck. In the alternative, vacuum ports, not shown, may be used to hold the substrate dielectric layer flat. See the aforementioned application Ser. No. 09/095,321, for example. This flatness of the layer A22 is important in order to control the thickness, and thus the volume, of the deposited powder/grains to the desired range.

It is important for example, that the deposited powder/grains at collection zones CZ, FIG. 6, do not vary from a

predetermined amount by more than about 5%. While this value may vary somewhat depending upon the drug or diagnostic agent being deposited, generally the value of about 5% variation from a predetermined amount of deposited powder/grains is sufficient for most applications. While such variation might be exceeded in the actual deposition of the powder/grains, the measurement station provides non-destructive actual measurements of the amount (i.e., the thickness over an area) of the powder/grain layers deposited at each of the collection zones CZ.

These values are stored in memory and displayed (display not shown) so that any unit dosage or diagnostic forms that exceed or are less than the desired range can be selectively discarded. In the present embodiment, a particular column of deposited powder/grains would be identified and discarded at a later processing step if any of the zones of that column are out of the desired range.

The deposition engine may be any known process for depositing the powder/grains. The engine disclosed in the aforementioned application Ser. No. 09/095,246 is preferred. However, the deposition processes of the aforementioned US patents and applications may also be used. The deposition in the former feeds powder/grains through an induction tube to which a bias is applied. This bias provides a charge of the desired polarity on the powder/grains. The tube is of a length sufficient to charge all of the expected powder/grain particles flowing therethrough to the deposition station 52. The particles flow into the chamber 69 via a nozzle (not shown).

The particles pass through an electrified metal control grid (not shown) that has a polarity of the charge on the powder/grains to repel the powder/grains. The grid is about 0.5 to 1.0 inches below the target, and biased about 500 volts per 1/2 inch at the polarity of the powder/grains. This action collimates the powder/grains as they are propelled upwardly toward the overlying chuck by the electrostatic forces on the chuck and toward the attached substrate 6 then receiving the powder/grains.

The grid also attracts the powder/grains with the wrong polarity. The grid may be parallel wires formed of a zig-zagging switchback of one wire or a grid of wires (not shown). The rate of powder/grain cloud of powder/grain flux can be monitored by measuring light attenuation between a light emitter (not shown), e.g., a laser, and a light detector (not shown). This value is transmitted to the controller 62, FIG. 1a.

A rotating baffle (not shown) is coupled to the nozzle (not shown) outlet in the deposition station 69 to disperse the powder/grains prior to the grid to more uniformly apply the powder/grains to the substrate 6. The baffle may comprise three equally spaced radially extending rotating planar baffle supports (not shown) on which rests a horizontal baffle disk (not shown) through which are a plurality of powder/grain aperture outlets. The powder/grains are fed to the nozzle with a gas at about 20 psi and about 2.5 liters per minute. The gas is preferably substantially free of water, oil and other impurities, and is preferably chemically inert such as nitrogen or helium.

The baffle should be preferably about 1/4 inch to about 1/2 inch above the outlet of the powder/grain charging feed tube nozzle such as 1/2 inch cross section where a 1/4 inch powder/grain charge feed tube nozzle is used. Rotating the baffle at about 5 to 25 revolutions per minute increases the uniformity of the powder/grain cloud reaching the target.

The powder/grains may be fed by an auger (not shown) rotating, e.g., 10 to about 80 RPM, to feed the powder/grains

to a Venturi feed valve (not shown). The auger is supplemented by the powder/grain Venturi feed tube which pulls the powder/grain from the auger and at the same time pushes the powder/grains through the feed tube to the nozzle at the chamber 69. A modified Venturi feeder valve with a Venturi well that delivers grains in a substantially straight line from the vertical auger feed to the powder/grain charging feed tube avoids compaction of the powder/grains falling to the bottom of the Venturi well. A simple gas source may be used in place of the Venturi to propel the powder/grains. A gas jet directs gas pressure toward the outlet of the mechanical device that feeds the powder/grains, the gas jet being adjusted to deagglomerate the powder/grains at the outlet.

Nitrogen may be used to feed the powder/grain particles via the venturi. The auger and feed tube connected to the auger through a venturi valve are vertically aligned. A vibrator (not shown) coupled to the feeding apparatus is preferable to keep the particles flowing. Other grain feed arrangements may also be used such as a gear wheel apparatus (not shown) or a jet mill (not shown) for dosages of about 2 μg to about 50 μg –100 μg applied to an area of about 3 to 4 mm diameter.

Induction induced charge may be applied to the jet mill by applying a potential to the mill such as with a 1,800 V potential. A suitable mill may be a TROST Air impact Pulverizer jet mill marketed by Plastomer Products Division of Coltec Industrial Products, Inc. This mill utilizes directly opposing streams of compressed gas and operates at a flow rate of about 2.0 to 2.2 liters/minute.

The powder/grains may be charged by triboelectric charging, the charge to the powder/grains colliding with the sides of its feed tube as the powder/grains transit the tube. Teflon, perfluorinated polymer may be used to impart a positive charge to the powder/grains and Nylon, amide based polymer, is used to impart negative charges. To minimize charge build up on the tube, the tube may be wrapped in metal foil or coated with conductive material such as graphite.

In the induction charging, a portion of the feed tube is stainless steel biased by one pole of a power supply with the opposite pole grounded. With an appropriate bias, an electric field is created in the stainless steel tube such that powder/grains passing through it pick up a charge. The length of the induction-charging tube is set to a sufficient length to assure the amount of charging desired. In one embodiment, induction charging is used in conjunction with tribocharging.

The charge relieved by the grounding procedures outlined above can be monitored to provide a measure of powder/grain flux the charging feed tube (not shown). This data can be sent to the controller 62 (FIG. 1a) to modify various parameters of the deposition apparatus. For example, a capacitor (not shown) can be put in series with the powder/grain charging feed tube to lower the potential generated by the charges collected in the charging feed tube. A 1 μF capacitor will build up 1 V for a 1 μC charge. The other pole of the capacitor is connected to ground potential. An electrometer (not shown) connected to the capacitor provides an accurate measure of collected charge.

Powder/grains not utilized at the deposition station are returned via a pressure differential through a powder/grain evacuation tubes (not shown) to a powder/grain trap (not shown). The trap utilizes biased baffles biased at for example either +2000 V or –2000 V. Grains not charged are charged by impact with a baffle of one polarity and collected by an oppositely charged baffle.

Shutdown of the deposition process for example as a result of the feedback data such as from the charge sensor or

pursuant to a timing schedule involves reducing the voltage (or the amplitude in the case of a pulsed voltage profile) directed to the powder/grain attracting electrodes, preferably to about 400 V from 2000 V, and shutting down the powder/grain feed apparatus. The amount of voltage reduction appropriate will vary depending upon such factors as the substrate, the powder/grains and the level of the powder/grains applied. The voltage is generally selected to maintain substrate adherence to the chuck and grain adherence to the substrate without attracting further grain accumulations.

The dose measurement station 48 includes apparatus 50 for measuring the thickness, i.e., the amount of powder/grains deposited on the substrate 109. Two optical measurement methods may be employed: diffuse reflection and optical profilometry. Diffuse reflection has been used to characterize powder/grains using light sources that emit in a range that is absorbed by the powders. A theory has been developed for using non-absorbing radiation which derived a term for the thickness of a powder/grain layer. It is believed that no commercial development has been made from this latter theory. Applicants have discovered that this measurement gives a strong correlation with the deposited amount, at least up to a certain amount, which varies with the character of the powder/grain/grains and are believed to correspond to amounts past which light penetration into lower layers is prevented.

Diffuse reflection is based on the reflection or scattering of a laser beam or a probe light beam off of the powder/grain surface into directions that are not parallel to the specular reflection direction. This scattered light is generally uniformly distributed in all directions. Dose depositions which exhibit this property are said to be "Lambert radiators," an important property for dose weight measurements.

In addition, the relation between the Lambertian scattering and the optical properties of powder/grains is defined by the scattering model of Kubelka and Munk. Non-absorbing radiation is used to create diffuse reflection. Typical radiation is the visible red lines provided by common gas and diode lasers such as 732.8, 635 and 670 nm. When non-absorbing radiation is used and when the dose deposition is of a finite thickness, d , the Kubelka-Munk model provides a known relation as disclosed in the aforementioned application Ser. No. 09/095,246.

In FIG. 11a, a diff-use reflection measurement apparatus 108 includes a laser 110. When a low energy beam from laser 110 impinges on deposited particles 111, the particles scatter LHT in all directions. To have a coherent laser, it is desirable that the laser be focused through beam splitting mirror 115. a reference beam detector 114 assists in determining the quality and intensity of the focused beam. The scattered light LHT is captured by an array of two or more detector zones 113. There can be for example 2 to 6 or more such zones. Amplifiers (not shown) may be used with the detectors. The detector zone outputs is connected to a commercial A/D converter (not shown). The resulting signal is scanned by using a computer controlled scanning mechanism 116, which is in communication with the central electronic processor of controller 62, to generate powder/grain thickness profile and thus the dose weight measurements of the depositions. Other methods for determining the amount of material deposited on a substrate may be employed and are within the skill of the art from the teachings herein.

It is preferred the powder/grains be deposited on a substrate that has a specular surface and the substrate be absorptive so that the measurement will not be sensitive to

diffuse reflections off of its back surface or off of the surface of the receiver **64**.

Diffuse reflection in non-absorbing regions provides a good accuracy in measuring dose deposition amounts ranging from $50\mu\text{400}\ \mu\text{g}$ or as high as $750\ \mu\text{g}$ to 1 mg. for a 3 or 4 mm diameter powder/grain deposited dot depending upon powder/grain characteristics. The powder/grain dots may have a diameter of about 4–7 mm in this embodiment. This method can detect substantially less than a monolayer of powder/grain.

If the deposit is more than a monolayer, accurate measurement requires that the probe light beam partially penetrate the upper layers so that it can be affected by the reflection off of the lower layers. However, to exhibit Lambertian characteristics, there tends to be a practical limit to suitable thickness, depending on the powder/grain. The diffuse reflection is also a measure of the physical uniformity of the dose deposits at the above ranging.

Optical profilometry is useful for the implementation of high dose measurements beyond the ranges that can be measured by the diffusion reflection method. In FIG. **11b**, a laser beam is focused on a high dose deposition **117** on substrate **109a**. The light is deflected with an angle of deflection indicative of the height of the deposition layer, which can be calculated by triangulation. The coherence of deflected light, which may be somewhat scattered, can be assisted by a lens **118** before the scattered light is captured by one or more position sensitive detectors **119**. The output data from the detector is scanned by using a scanning mechanism **116** to generate a profile of the powder/grain surface.

The profilometer can be, for example, a confocal profilometer, meaning light is directed to the substrate through a lens system, and returned light passes at least in part through the same focusing system, though typically the returned light is reflected to a detection site. In one suitable confocal profilometer, a Model LT8105, Keyence Corp., Japan, or Keyence Corporation of America, Woodcliff Lake, N.J. focuses source light through a pinhole, and a similar focusing through a pinhole of the return light helps establish focus. A source of back and forth dithering movement applied to one of the lenses helps establish oscillations in the focus which help identify the optimal focus point.

In one embodiment, a slit can be used in place of a pinhole and a spatially resolvable light detector, such as a charge-coupled device (CCD), is used to simultaneously retrieve data for multiple points along a linear area of the substrate. In some embodiments, there can be an issue of the powder/grain attracting electrode or some other feature of the receiver creating strong reflections that could overwhelm efforts to establish the baseline surface of the substrate. However, since the substrate is preferably uniform, these issues can be normalized away. Once material is deposited on the substrate, or where the substrate is sufficiently opaque, clean reflections can be obtained.

To obtain accuracy by optical profilometry, a pre-dose measurement of the substrate **109a** is preferred. The beam is scanned across the surface and the height of the surface from a reference location is established by triangulation. The difference in height from the reference before and after the deposition is calculated. This difference is attributable to the dose weight.

This difference is calculated for each column of collection zones CZ, FIG. **6**, and for each collection zone CZ. The controller **62** stores these values in memory and displays the difference as a measure of the dosage amount for each

dosage unit. When any of the individual unit dosage amounts is beyond the predetermined amount by the preferred 5% value, those units can be later identified and selectively discarded for each substrate that is produced and measured providing 100% inspection with non-destructive testing of the actual amounts of each unit.

Since dry powders/grains are generally good diffuse reflectors, it is convenient to use an optical triangulation system that is optimized for diffuse reflection. To determine the pre-dose surface profile, and to establish the height of the substrate at issue during the post-dose measurement, it is preferred that the substrate surface **109b** be also diffuse. The surface should also be absorptive so that the triangulation system not be confused by reflections from the back surface of the substrate or from the receiving system.

For purposes of illustration, only a single laser **110** is shown. However, more than one laser can be used to impinge on the powder/grain particles in different areas of a deposition site. The scattered light is captured by different detection zones which ultimately are scanned for the desired characterization.

In some embodiments, the deposition sites are excited in succession and the powder/grain profile is characterized after each light source excitation through the scanning mechanism **116** by moving the scanner, for example, from a first site to a second site and so on until all of the deposition sites are characterized.

In other embodiments, more than one deposition site is laser excited at a time and data is obtained by scanning the sites simultaneously. In such situations, it is desirable to optimize conditions for reducing the interference from nearby sites that are being characterized simultaneously. This can be accomplished by, for example, optimizing the spacing between deposition sites or by alternating the excitations of different sites.

It is desirable that the laser be movable in different directions. An industrial process grade (x,y) stage can assist the laser to move in the x,y directions. A solid state laser suitable for industrial applications such as, for example, LAS-200-635-5 from LaserMax Inc. can be used as a laser source. the detectors can be any suitable device, preferably, silicon, detector such as those sold by UDT Sensors, Inc. (Hawthorne, Calif.). alternatively, large area solar cells can also be used.

It is often desirable to combine both of the dose measurement systems into a single system so that both the low dose and high dose measurements can be made and the range of the dose measurement is not limited by any single method used.

In FIG. **12**, substrate **109** is striated and is useful for both the profile and diffuse reflection systems. Striated substrate **109** has surface striations running in only one direction. The surface profile measurements are made by positioning the triangulation system with incident and reflected beams in a plane perpendicular to the striation direction. The striations thus act like a diffuse surface for this measurement. The diffuse reflection measurements are made in a plane that contains the striations.

Ideally, striations do not scatter light in a direction parallel to themselves, so that any scattered light is attributable to the powder/grain on the surface. For both measurements, the substrate can also be dyed so that reflections from the substrate's back surface or from the receiving system's surface do not interfere with the measurement of either the profile or of the diffuse reflection. The system of FIG. **12** combines two modes of measurement with the use of just

one light source, while the system of FIG. 14, discussed below, shows a system where measurement modes each have a separate light source.

In embodiments that do not use frames or another mechanism for alignment of the substrate at the deposition station and the measurement station are the same, the dose measurement system is arranged to identify the positions of the depositions. Such a mechanism could be a video camera that collects data, for example, in a charge-coupled device (CCD) and electronics to analyze the contents of the CCD to determine the boundaries of the depositions.

It should be understood that the unit pharmaceutical or diagnostic dosage powder/grains deposited at a collection zone CZ are measured both in area and thickness to provide a volume measure manifesting the amount of powder/grains deposited in a deposited collected powder/grain dot at each zone. The above diffuse and profilometer measurements while described in terms of thickness are also measured in conjunction with areas that are determined by the scanning beams.

Adjacent scan beams are closely spaced, for example 1 mm apart, so that the transverse region occupied by a collection zone CZ is also measured and considered in the calculations of the amount of powder/grains present at each deposited location. The beams are about 6 μ (microns) in diameter in this embodiment. For a deposition zone of about 4–7 mm, each deposited powder/grain dot will be scanned with four to seven scans, respectively. These scans are then used to calculate the amount of dosage at each collection zone CZ. The system remembers the calculations for each zone for future selective screening of out of specification of pharmaceutical or diagnostic unit dosage forms.

Polyethylene glycol (PEG) powder, by way of example, in a about 3 mm diameter dot has been deposited onto a Mylar substrate. The diffuse reflectance data was obtained using a laser (670 nm) based Keyence instrument (Keyence Corp. of America) operating in the intensity mode. Data was obtained using different, usually larger, fractions of the diffusely scattered light. The analytical properties of the measurement did not appear to be very sensitive to the fraction of collected light, i.e., the measurement is, in this context, unusually robust and ideal for use as an industrial measurement process.

The data set forth in Table I below which was obtained using diffuse reflection method was the basis for the graph of FIG. 13, for the four points of the data set. The first three points were highly correlated and the least squares fit gave an R value, a measure of correlation, of 0.999. Perfect correlation gave a maximum value of R which is 1 and, with less correlation, the value is correspondingly less than 1. The fourth point show variation and the least squares fit for the data set as a whole gave an R value of 0.98. Both R values were well within accepted norms for analytical procedures to determine dry powder/grain dose weights.

TABLE I

Experimental diffuse reflectance and dose weight data	
PEG Dose Weight, Micrograms, by Assay	Calculated R/(1-R)
108.6	0.35
86.6	0.312
50.6	0.254
36.6	0.201

Subsequent measurements had shown that a high degree of correlation existed for the diffuse reflection and dose

weight for various types of dose samples. Based on these data, the degree of correlation is thought to be closely related to the structure of the dose, specifically whether the structure exhibits Lambertian characteristics.

In FIG. 14, a detection array 130 is mounted on a support (not shown) in the measurement station. The support is positioned on a detection platform (not shown) at the measurement station. The detection array 130 includes a diffuse reflectance system comprising a diffuse reflectance light source 110A and detection zones 132–137, inclusive.

A profilometry system comprises profilometry light source lens 138. Lens 138 is part of a confocal system so that returned light passes through the same lens. The diffuse reflectance light source 110A is, for example, offset from the center point (where lens 138 is located) so that specular reflections, as opposed to diffuse reflections will be centered in an area 140 and away from the detector zones 132–137. These zones 132–137 include detectors that are preferably angled and arranged to accept only light from an appropriate direction.

After the dose unit measurement step, the robot 46 moves the electrostatic chuck 68 and the attached substrate 6 and frame assembly with the deposited powder/grains to the lamination station 54, FIG. 1. During this period the reduced 400 V. holding signal is applied to the chuck electrodes at the collection zones CZ to hold the powder/grains to the chuck and the substrate flat against the chuck. The frame is continuously held to the chuck by the vacuum through the holes ECH, FIG. 6.

During deposition, a relatively high voltage, e.g., 2000 V as mentioned above, is used to create a deposition charge at each collection zone. This charge also holds the substrate flat against the electrostatic chuck during deposition. The charge also holds the dots of deposited powder/grains to the substrate which is in inverted orientation with the powder/grains beneath the substrate. After the desired deposition value has been sensed by the charge sensor circuit, the deposition voltage value is reduced sufficiently to stop the deposition of powder/grains. However, a charge is maintained at the reduced voltage sufficient to hold the base substrate 6 flat against the electrostatic chuck 68 and to hold the deposited powder/grains to the chuck as the chuck 68 is displaced to the measurement and lamination stations.

Just prior to this time, the substrate cover 4 is transported to the lamination station 54 by robot 56 from an input/output station 32. The cover 4 is placed on fixture 122. The depressions 8 of the cover 4 are placed in aligned mating depressions in the fixture 122. Alignment devices, e.g., pins and holes, on the frames of the substrate assemblies 32 and 34 and at the lamination station fixture 122 assure that the locations with the deposited powder/grains on the base substrate 6 are matched with the depressions 8 in the cover substrate 4, FIG. 5.

The robot 46 then transports the base substrate 6 and frame assembly 34 from the measurement station 48 measuring apparatus 50 over the fixture 122 and places the substrate 6 with the deposited dosages on the cover substrate 4, FIG. 5. At this time the deposited dosages are no longer held in place by charges.

The robot 56 at the lamination station has vacuum cups (not shown) and an ultrasonic welding head 124. After the head of robot 46 moves away from the station 54, the robot 56 returns to perform the welding operation. The robot 56 head has a pad 126, FIG. 5, that holds the two substrates in intimate tight contact prior to the start of the welds. Once the other robot 46 releases the substrate 6, the electrostatic

charge on the chuck 68 holding the deposited dosages in place is removed. The powder/grains are thus free to move about at this time. The pad 126 compresses the base substrate 6 against the cover substrate 4 to lock the powder/grains in place in the depressions 8 during the weld operation.

The weld head 124 then commences welding the substrates to form each unit form whether of dosage or diagnostic active ingredients. The welds may be made one form at a time or preferably by one or more weld heads simultaneously for all of the dosage forms on the substrates on the fixture 122. When the welds are complete, the robot 56 displaces to its idle position and the final package of dosage forms is removed for final processing.

It will be appreciated that other sealing methods may be employed such as thermal or adhesive lamination. The illustrated bonding method is useful when one desires to keep the deposited powder/grains free of admixture with other components such as film polymers, though it will be recognized that this can be achieved in other ways.

In operation, covering frames and substrate assemblies 32 are stored at stations 30b and 30c, FIG. 1. The frames are located by holes in the frames mating with pins in the stations. The base frames and substrate assemblies 34 are stored at station 30a and are also located by mating pins and holes. The robot 46, moves the receiver 64 to the station 30a. Alignment mechanisms in the receiver comprising alignment holes 65 and pins 67, FIGS. 8 and 9, mate with pins and holes at the input/output and alignment stations for aligning the robot receiver, and chuck 68 to the stored frame and substrate assemblies. Similar alignment mechanisms are located on the cover and welding robot 56.

In the profilometer process, robot 46 picks up the assembly 34 and carries it to the alignment station 44. Here the substrate assembly 34 is aligned to the electrostatic chuck via the alignment mechanisms 40, FIG. 8, on the chuck to assist in the alignment of the chuck to the substrate.

The assembly 34 is then transported from the alignment station 44 to the measurement station and aligned with the measurement apparatus 50. The apparatus 50 then scans the substrate 6 and records its distances at each of the collection zones CZ, FIG. 6, to the reference location as discussed above.

The robot 46 then transports the measured empty substrate 6 and frame assembly 34 to the deposition station 52. The frame is during this time secured to the chuck via the vacuum ports slot holes ECH. At the deposition station, the frame is placed on gasket 67 in a sealing relation therewith. Then the powder/grain deposition engine is turned on and the powder/grains deposited as described.

At the end of the deposition, the deposition voltage is reduced to stop the deposition, but maintained at the reduced value to hold the deposited powder/grains and substrate to the chuck. The robot 46 returns the substrate 6 and deposited powder/grains to the measuring station 48 to measure the distance to the deposited layers of powder/grains of active pharmaceutical ingredients or diagnostic ingredients at each zone CZ. The distances are measured and the volume amounts of deposited powder/grains calculated for each dosage or diagnostic collection zone. After measurement, if the calculated amount is outside the desired range from a predetermined amount, the information is displayed. The operator can then make adjustments to the voltages on the receiver to correct the deposition values.

In the alternative, automatic feed back can be provided to automatically adjust the voltages for a given set of collection

zones. The system remembers which zones are defective and the operator or automated system can then remove and discard the out of specification unit dosage or diagnostic forms.

In an automated system, the laminated unit forms may be automatically transferred to a packaging station for screening out of specification unit forms and for packing the unit forms in the desired packaging.

It will occur to one of ordinary skill that various modifications may be made to the disclosed embodiments. Such modifications may include testing each unit dosage form by techniques other than laser scanning, for example.

Further, feedback may be provided based on the measured thickness of active ingredient for automatically adjustment such that the thickness of the deposited pharmaceutically active ingredient is reset during the measuring of the active ingredients of the next preceding formed plurality of unit dosage forms.

Further, while an induction device is preferred for inducing charges on the active ingredient particles, other known techniques may be used to charge these particles.

It is intended that the invention be defined by the appended claims and not by the disclosed embodiments, which are given by way of illustration, and not limitation.

The present invention is particularly applicable to pharmaceuticals that are presently administered in liquid form, as solutions or suspensions. It is to be understood, however, that the pharmaceutical may also be one that may be administered in a solid dosage form. As representative but not limiting examples of such pharmaceutical solutions and suspensions, there may be mentioned:

EXAMPLES OF OFFICIAL ORAL SOLUTIONS AND ORAL SUSPENSIONS

Official Oral Solutions

Abacavir
Acetaminophen
Aminophylline
Chloramphenicol
Cloxacillin
Cyclosporine
Guafenesin and theophylline

Haloperidol
Isosorbide
Nafcillin
Neomycin
Oxacillin
Oxycodone
Penicillin G
Penicillin V
Potassium chloride
Prednisone
Sodium fluoride

Official Oral Suspensions

Acetaminophen
Amoxicillin
Ampicillin
Bacampicillin
Cefaclor
Cefadroxil
Cephalexin
Cyclacillin

Doxycycline
Erythromycin
Griseofulvin

Indomethacin
 Naproxen
 Nystatin
 Penicillin V
 Phenytoin

Other pharmaceuticals that may be administered in accordance with the present invention include, but are not limited to, amlodipine, atorvastatin, betaxolol, bisoprolol, buspirone, candesartan, cilexetil, carvedilol, enalapril, etedolac, felodipine, fosinopril, gabapentin, lamivudine, lamotrigine, lisinopril, lovastatin, moexipril, montelukast, nabumetone, nevirapine, oxaprozin, oxycodone, quinapril, ranitidine, rifapentine, sotalol, and zafirlukast. The above-mentioned pharmaceutically active agents also include any pharmaceutically acceptable salts.

The present invention is particularly advantageous in that it is no longer necessary to prepare liquid oral solutions containing multiple dosages of the desired pharmaceutical. Moreover, at the time of use, it is possible to administer orally a pharmaceutical, as a liquid, without requiring measurement of the liquid dosage in that the proper dosage can be administered by adding the solid unit dosage form to a pharmaceutically acceptable liquid, such as water, without measuring the liquid, and then consuming the entire liquid contents.

In addition, the present invention eliminates the prior art problems with respect to the stability of liquid pharmaceutical preparations, and the necessity for the pharmacist to prepare the liquid preparation, in multiple dosage units, in which there may be possible inaccuracies in the formulation of the proper dosage of the pharmaceutical in the multi-dosage liquid preparation.

These and other advantages should be apparent to those skilled in the art from the teachings herein.

Numerous modifications and variations of the present invention are possible in light of the above teachings and, therefore, within the scope of the appended claims, the invention may be practiced otherwise as particularly described.

What is claimed is:

1. A process for administering a pharmaceutical in a pharmaceutically acceptable liquid carrier, comprising:

(a) at the time of use, adding ex vivo to a pharmaceutically acceptable liquid carrier a solid unit dosage form, said solid unit dosage form comprising a substrate that disintegrates in the liquid carrier, at least one particulate pharmaceutically active material deposited on the substrate as a layer distinct from the substrate, said at least one pharmaceutically active material being present on said substrate in a pharmaceutically effective amount, and a cover sheet that disintegrates in the liquid carrier, said cover sheet being disposed over said pharmaceutically active material and sealed to said substrate, whereby said substrate and said cover sheet form an enclosure for said at least one pharmaceutically active material, and whereby said at least one pharmaceutically active material can be delivered orally in the liquid carrier in a pharmaceutically effective dosage without measuring the quantity of liquid carrier at the time of use; and

(b) administering orally said at least one pharmaceutically active material and said liquid carrier to said animal.

2. The process of claim 1 wherein said pharmaceutically acceptable liquid carrier is water.

3. The process of claim 1 wherein said substrate is comprised of at least one material selected from the group consisting of gelatin, hydroxypropylmethylcellulose, hydroxypropylcellulose, polyvinyl alcohol, polyethylene oxide, polyvinylpyrrolidone, sodium alginate, carboxymethylcellulose, and agar.

4. The process of claim 1 wherein said at least one pharmaceutically active material is an antibiotic.

5. The process of claim 1 wherein said pharmaceutically active material is an anti-viral agent.

6. The process of claim 1 wherein said pharmaceutically active material is an anti-fungal agent.

7. The process of claim 1 wherein said at least one pharmaceutically active material is an anti-infective agent.

* * * * *