

J. L. MOTT.
Cooking Stove.

No. 6,530.

Patented June 12, 1849.

FIG. 2.

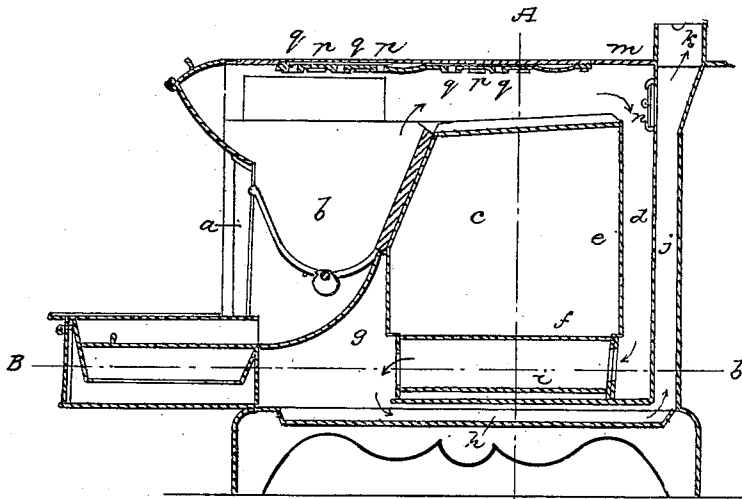

FIG. 1.

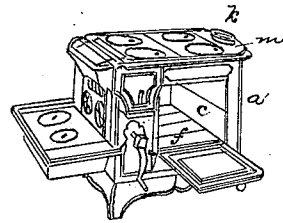

FIG. 3.

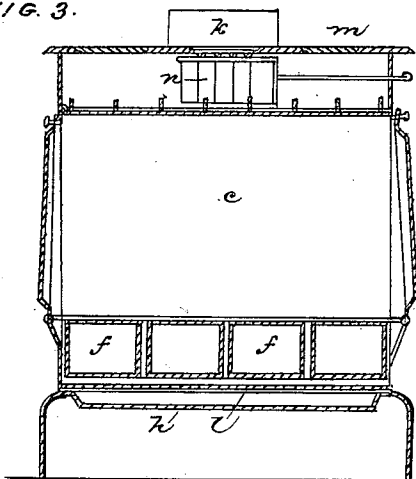

FIG. 4.

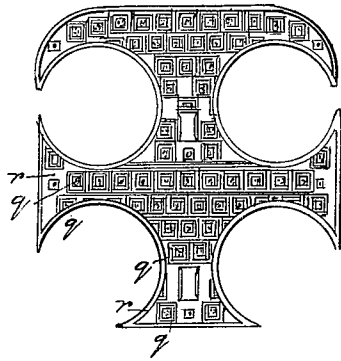
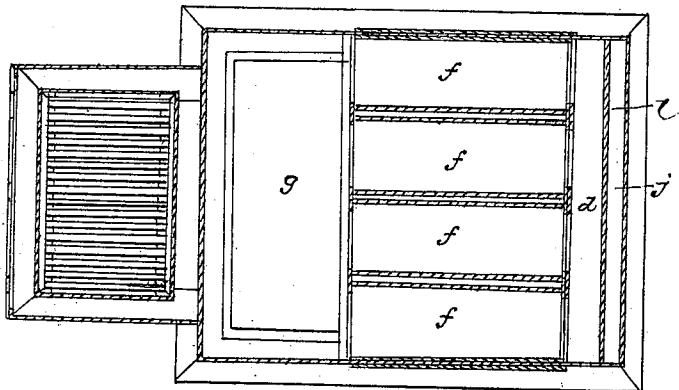

FIG. 5.



UNITED STATES PATENT OFFICE.

JORDAN L. MOTT, OF NEW YORK, N. Y.

COOKING-STOVE.

Specification of Letters Patent No. 6,530, dated June 12, 1849.

To all whom it may concern:

Be it known that I, JORDAN L. MOTT, of the city, county, and State of New York, have invented certain new and useful Improvements in Cooking-Stoves, and that the following is a full, clear, and exact description of the principle or character which distinguishes them from all other things before known and of the manner of making, constructing, and using the same, reference being had to the accompanying drawings, making part of this specification, in which—

Figure 1 is a perspective view of my improved stove; Fig. 2, a longitudinal vertical section; Fig. 3 a cross vertical section taken at the line (A a) of Fig. 2; Fig. 4 a reversed view of the shifting parts of the top; and, Fig. 5 a horizontal section taken at the line (B b) of Fig. 2.

The same letters indicate like parts in all figures.

The first part of my invention relates to the mode of equalizing the heat in the oven, and consists in carrying the flame and other products of combustion from the fire chamber over the oven in a single sheet, down a diving flue at the back, also in a single sheet,—the inside plate of the oven being either flat or corrugated, and then through a series of tubes constituting the bottom of the oven, the said tubes being sufficiently separated to cause the heat radiated from the entire surface to pass into the oven, when those are combined with a return flue at the bottom and at the back which extends the whole width or nearly so, of the oven that the heat radiated from the top plate of the bottom return flue may pass into the oven and thereby increase the heating or radiating surface at the bottom, and to prevent the heat from being radiated into the room from the diving flue, that the ratio of the decreasing radiating surface may be increased in the inverse ratio of the intensity of heat of the products of combustion, the said return flue in the bottom and at the back having the effect at the same time of preventing the waste of heat by radiation from the outside of the direct flues within these.

The second part of my invention relates to a method of protecting the top plate of the stove, or the movable and shifting parts thereof, from injury by reason of the intense heat to which it or they are exposed, and this part of my invention consists in

having such plate or plates with a perforated plate or plates with some refractory earthy cement, either interposed between them, or in hollow cells that project down from the under surface of the lining.

In the accompanying drawings, (a) represents the external form of my stove, which may however be varied at pleasure, and (b) the fire chamber in front of the oven, (c) the flame and other products of combustion pass directly from the fire chamber over the top of the oven, down the diving flue (d) the whole width of and at the back of the oven, the back plate (e) of which may be either flat or corrugated. The lower end of this flue leads into a series of horizontal tubes (f), that form the bottom of the oven, and placed at such distance apart as to leave a space between them for the free passage into the oven of the heat radiated from the sides and bottom of the tubes. At the forward end these tubes open into a chamber (g) which communicates with the forward end of a horizontal return flue (h), which extends entirely under the series of tubes, the top plate (i) of which is at such distance below the lower surface of the tubes, as that the heat radiated from the lower surface of the tubes and the entire surface of this top plate may circulate and pass up between the tubes into the oven. And the rear end of this bottom return flue opens into a vertical return flue (j) back of the diving flue (d) and leading to the exit pipe (k) this latter flue having the effect to prevent the heat radiated from the back plate of the diving flue from being wasted, and therefore causing a more intense radiation into the oven.

The division plate (l) between the driving flue (d) and the vertical return flue (j) extends up to the top plate (m) of the stove, and is provided with a sliding damper (n) in the usual manner, to give a direct draft from the fire chamber to the exit pipe, when it is not required to heat the oven.

The top plate (m) of the stove is a mere rim, the open space within being provided with shifting pieces (o), to vary the size and position of the boiler holes. The shifting pieces are made double, as shown in the drawings, the under half (p) being pierced with holes (q) and riveted on or otherwise secured to the upper half, leaving a sufficient space between for the insertion of some

earthy cement or other refractory substance which passes through the holes (*g*) to the under surface of the plate. The space for the cement between the two plates is formed
 5 by curving down the under plate so that at the edges the two plates may be united, or instead of having a space between the two for the cement, the lining plate may be cast with hollow projections (*r*), which are filled
 10 with cement. By the interposition of the cement and under perforated plate, the upper plate is entirely protected against warping and cracking by the intense heat to which such plates are exposed in cook-
 15 ing stoves.

I wish it to be distinctly understood that I do not limit myself to the application of this method of lining and protecting plates to the shifting plates used on the tops of
 20 stoves, but that the same may be applied to the tops of stoves when made in any other way.

From the foregoing it will be seen that the top of the oven is heated above by the
 25 passage over it of the flame and other products of combustion as they come directly from the fire chamber, and where the heat is most intense, that the back is heated by the passage of these products of combustion
 30 down th diving flue, and as the heat is less intense there than at the top the radiation is increased by the return flue at the back of the diving flue which prevents the escape
 35 ated into the room from the back plate of

the diving flue. And that at the bottom where the intensity of heat of the products of combustion is still less the radiation is increased by the enlarged radiating surface
 40 of the tubes and the top plate of the bottom return flue below them. The front of the oven is heated by the fire back, and as stated above the back plate of the oven may be made flat, but if it be found that this part
 45 is not heated enough by reason of the addition of the vertical flue back of the diving flue, the said back plate of the oven may then be corrugated, as specified above to increase the radiating surface.

What I claim as my invention and desire
 50 to secure by Letters Patent is—

1. The method, substantially as described, of equalizing the heat in the oven by combining with the diving flue at the back, and
 55 the series of tubular flues at the bottom with spaces between them, the return flue below the flue tubes and the return flue at the back of the diving flue, substantially as described.

2. And I also claim the method of protecting the box plate of the stove, or the
 60 parts thereof by lining it or them with a perforated plate or plates with some earthy cement or other refractory substance interposed between the plate or plates and the perforated lining, as described.

JORDAN L. MOTT.

Witnesses:

AUGUSTUS F. WEEKES,
 JORDAN M. MOTT.