

April 7, 1953

E. WAGNER ET AL
CHANGEABLE DISPLAY SIGN

2,633,652

Filed June 7, 1950

4 Sheets—Sheet 1

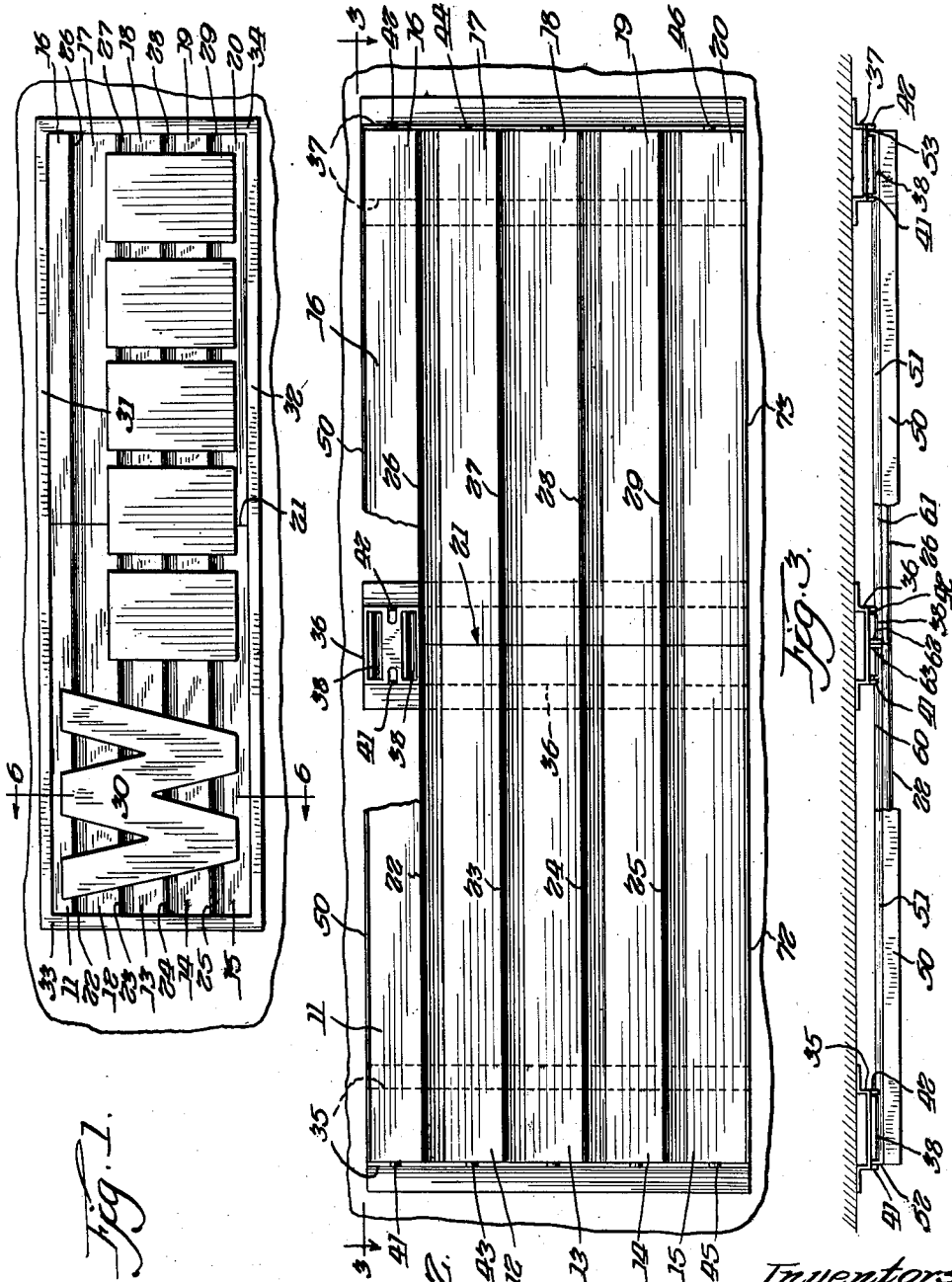

Fig. 1.

Fig. 2.

Fig. 3.

Inventors:
E. Fritz Wagner, G.
Walter S. Wagner.
By *M. J. Owen* Atty.

April 7, 1953

E. WAGNER ET AL
CHANGEABLE DISPLAY SIGN

2,633,652

Filed June 7, 1950

4 Sheets-Sheet 2

Fig. 4.

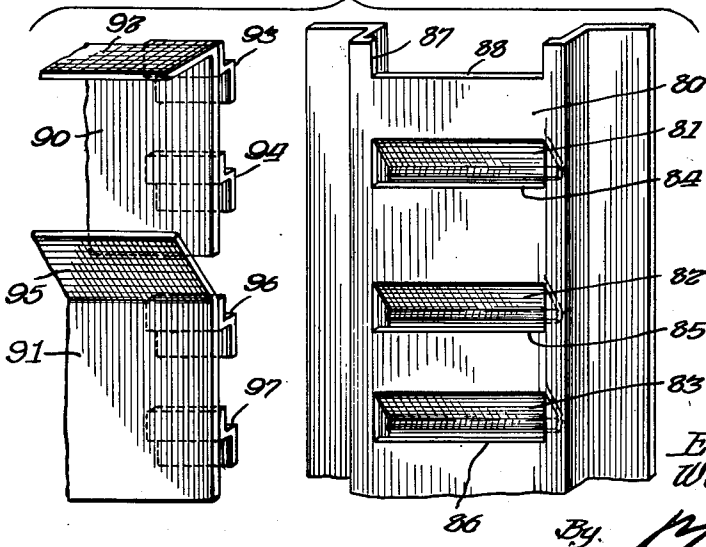
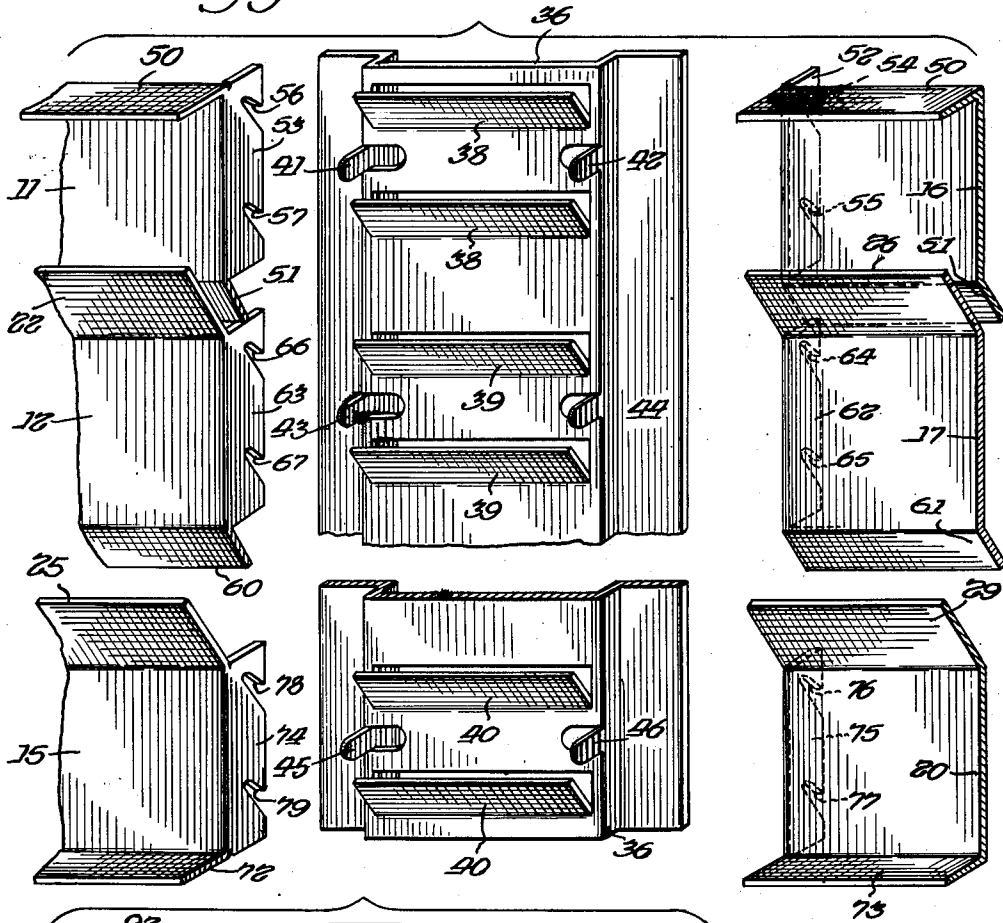

Fig. 5.

Inventors.
Erwin Wagner &
Walter S. Wagner.

W. S. Wagner
Atty.

April 7, 1953

E. WAGNER ET AL

2,633,652

CHANGEABLE DISPLAY SIGN

Filed June 7, 1950

4 Sheets-Sheet 3

Fig. 6.

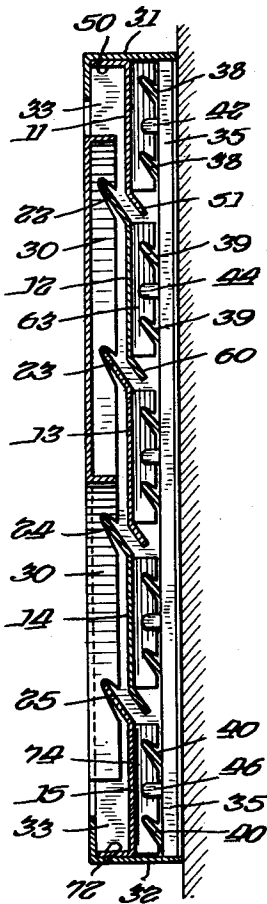

Fig. 8.

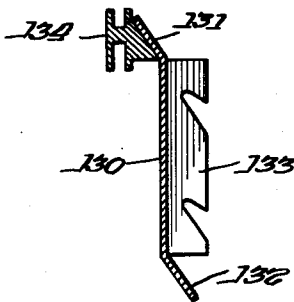
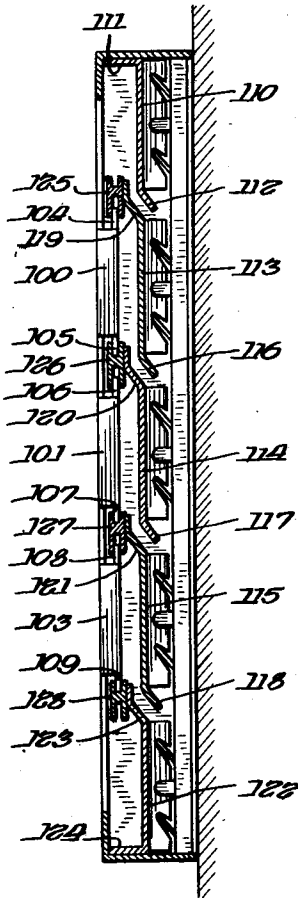

Fig. 9

Inventors.
Erwin Wagner, E.
Walter S. Wagner.
By *[Signature]* Atty.

April 7, 1953

E. WAGNER ET AL
CHANGEABLE DISPLAY SIGN

2,633,652

Filed June 7, 1950

4 Sheets-Sheet 4

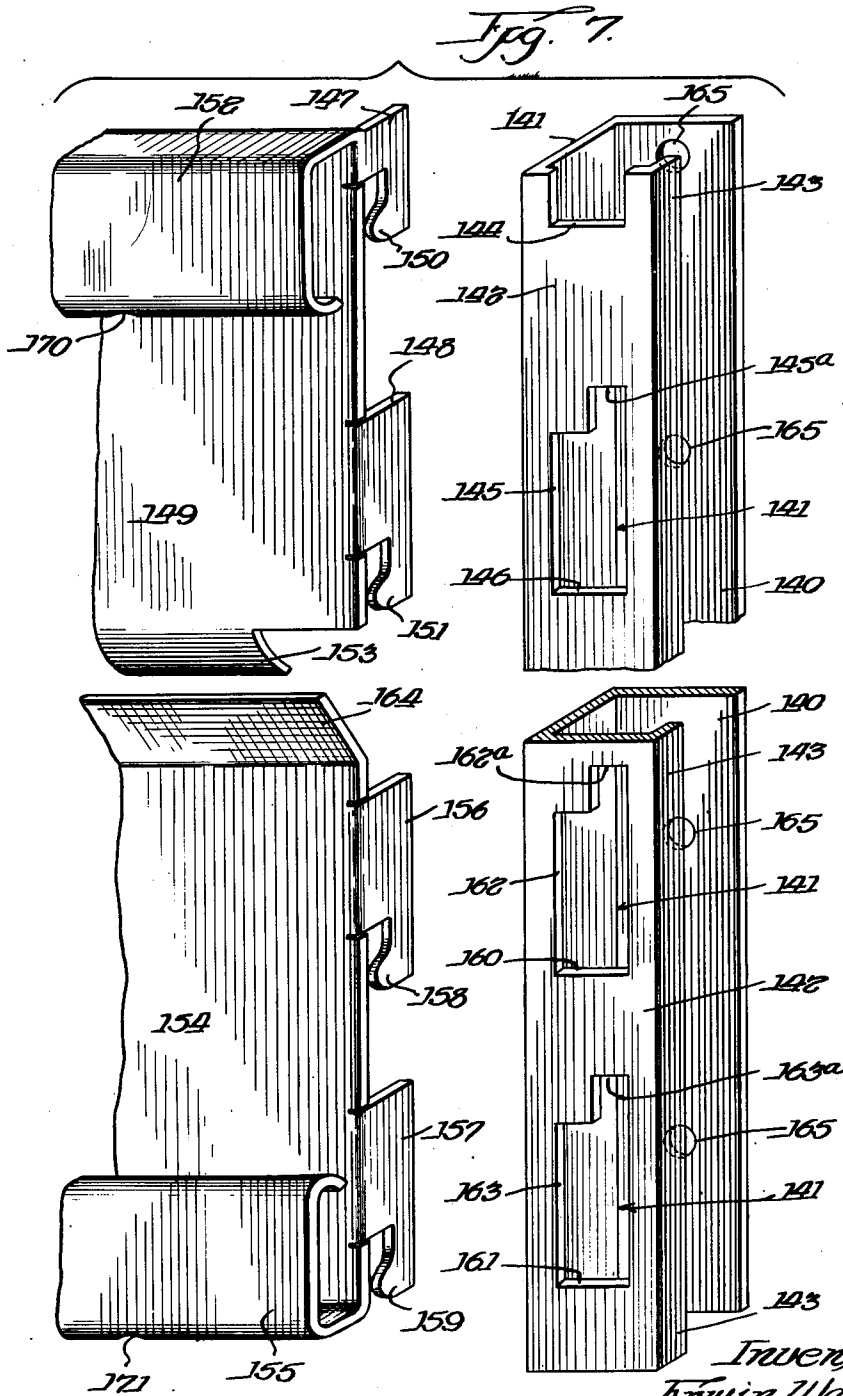

Inventors:
Erwin Wagner &
Walter S. Wagner.
By *[Signature]* Atty.

UNITED STATES PATENT OFFICE

2,633,652

CHANGEABLE DISPLAY SIGN

Erwin Wagner and Walter S. Wagner, Chicago, Ill., assignors to Wagner Sign Service, Inc., Chicago, Ill., a corporation of Illinois

Application June 7, 1950, Serial No. 166,568

14 Claims. (Cl. 40-143)

1

This invention is concerned with changeable display signs of the type described in U. S. Patent No. 2,224,069.

The principal object of the invention is to provide a sign which is composed of a few structurally simple and easily manufactured parts, essentially only two parts, which may be assembled to form signs of different sizes and display capacities.

This principal object is realized by providing (a) a simple mounting member which may be furnished in desired length, depending on the height of a given sign, to form a desired plurality of horizontally spaced uprights, depending on the length of the display background surface of the sign, for removably mounting thereon (b) a plurality of panel-like background members each forming a portion of the background surface and all but one of said background members also forming carrier means for removably mounting thereon symbols to form a desired message.

The term "symbols" is intended to refer to letters or characters such, for example, as disclosed in U. S. Patent No. 2,048,040.

Details of the invention will appear from the description which will presently be rendered with reference to the accompanying drawings.

In these drawings,

Fig. 1 is a diagrammatic elevational front view of a display sign made in accordance with the invention;

Fig. 2 shows the sign of Fig. 1 with the border or frame and also the symbols removed and some of the background panels broken away to show underlying portions of one of the upright mounting members.

Fig. 3 illustrates a top view of the interior structure of the sign, as seen when looking in the direction of the arrows along lines 3-3 in Fig. 2;

Fig. 4 represents an exploded perspective fractional view of parts of the sign shown in Figs. 1 to 3;

Fig. 5 is an exploded fractional view of a modification;

Fig. 6 shows a diagrammatic section through the sign shown in Fig. 1, taken approximately along lines 6-6 in Fig. 1;

Fig. 7 illustrates an exploded view of parts of another embodiment;

Fig. 8 illustrates a sectional view through a sign analogous to the view shown in Fig. 6, but having adapter means for accommodating symbols of different structure, namely, lug type symbols; and

Fig. 9 represents a sectional view through one of the background panels which may be equipped

2

with an adapter for supporting symbols of the lug type, as indicated in Fig. 8.

The sign shown in Figs 1-4 and Fig. 6 comprises a plurality of strip- or panel-like background members 11-15 and 16-20, respectively. The inner ends of these background members abut along the line 21 approximately in the center of the sign. Each of the background member 12-15 forms an angularly forwardly tilting carrier ledge, as indicated by numerals 22-25, and each of the background members 17-20 forms a similar angularly forwardly tilting carrier ledge, as indicated by numerals 26-29. These carrier ledges likewise abut along the line 21 approximately in the center of the sign, thus forming horizontally continuous lines or ledges for supporting desired letters, characters of other symbols to form a desired message.

Some of these symbols may be larger than others. In Fig. 1 it is assumed that the letter "W," marked by numeral 30, is the largest, extending over the four lines or carrier ledges 22-25 of the background panel members 12-15, while the remaining letters or symbols are somewhat smaller, each extending over only three carrier ledges or lines, namely, over the three carrier ledges or lines 23-25 of the background panels 13-15 at the left side of the center line 21 and over the corresponding three lines or carrier ledges 27-29 formed by the background panels 18-20 at the right side of the center line. The size of the letters or symbols shown in Fig. 1 is intended only to give an example, because it is understood of course that the letters or symbols may be of different size, and some of them may cover only two of the carrier ledges, others three, and still others four, while it is also possible that some of the symbols, for example, such as a comma or a period, may be suspended from only one of the carrier ledges. Each symbol or letter has rearwardly extending flanges which are angularly slotted as indicated in Fig. 6 in connection with letter "W" marked by numeral 30.

A marginal border or frame comprising longitudinal top and bottom sections 31, 32 and the end sections 33, 34 is provided in order to present a neat and finished appearance. Portions of the frame may be formed by means carried by the top and bottom panels, respectively, as will be presently described.

The sign may be disposed as desired, e. g., in a recess in a wall or on the front surface of a wall. There are provided for this purpose a number of cross-sectionally, generally U-shaped channel members 35, 36, 37 which are suitably secured to

3

the supporting structure by means of their flanges. These channel or upright mounting members are alike, and a description of one, namely, the centrally disposed upright mounting member 36, will suffice for all.

Referring particularly to Figs. 2, 3 and 4: Each upright mounting member forms a plurality of pairs of angularly forwardly projecting ledges such as 38, 39 and 40, one pair of such ledges for one end of each of the panel background members 11-15 and 16-20, respectively. These ledges are punched out from the central wall of the upright channel member. Each of these ledges forms a carrier for removably supporting the associated end of the corresponding panel background member. Associated with each pair of carrier ledges are stop members such as indicated at 41/42, 43/44, 45/46 which are likewise punched out from the front wall of the channel upright and project perpendicularly therefrom. The inner edges of these stop members are in substantially vertical alignment with the outer edges of the associated ledges 38, 39 and 40, respectively.

The uprights may be formed differently, e. g., as shown in Fig. 7, or they may be made from flat strip material with the carrier ledges and with the stop members punched out and pressed out forwardly, as described. If flat striplike uprights are used, they may be provided with tubular bushings at predetermined points, for accommodating bolts or screws which secure them to the supporting structure, wall or the like. Each of the bushings may somewhat project from the plane of the upright in order to provide slight spacing from the supporting structure. Spacer washers may be used, if desired.

Each of the panel-like background members may be made of suitable sheet material and may have a desired surface finish; for example, the surface may be enamelled.

The background panel members 11 and 16 on top of the structure are alike, each forming a body portion extending in a plane substantially in parallel with the plane of the supporting surface, e. g. the surface of a wall. The material of the body portion is bent forwardly on top to form a forwardly projecting ledge 50. At the bottom, each of these top panel members is bent angularly rearwardly, as indicated at 51, to form a downwardly and rearwardly depending skirt so as to provide for drainage of moisture. At the opposite ends each panel member is bent rearwardly to form the flanges 52 and 53, respectively, and each of these flanges is angularly notched, as indicated at 54/55 and 56/57, respectively.

All of the intermediate background panel members 12-14 and 17-19, respectively, are alike, and the description of two of them, namely, the panel members 12 and 17, will suffice for all. Each forms again a body portion which extends substantially in parallel with the surface of the supporting structure. The top of the body portion is bent angularly forwardly to form the carrier ledge 22 (panel member 12) which is, in the assembled position, in alignment with the corresponding carrier ledge 26 of the background panel member 17. At the bottom each such background member is bent angularly rearwardly, as indicated in Fig. 4 at 60 and 61, and the opposite ends of each panel member are bent rearwardly to form the flanges 62, 63 each of which is slotted as indicated at 64/65 and 66/67, respectively.

The background panel members 15 and 20 dis-

4

posed at the bottom of the sign are alike, each forming an angularly forwardly projecting top carrier ledge, as indicated in Fig. 4 at 25 and 29, with the bottom portion bent forwardly perpendicular to the plane of the body portions, as indicated at 72 and 73. The opposite ends of each of these background members are again bent rearwardly to form flanges 74 and 75, and each of these flanges is again angularly slotted, as indicated at 76/77 and 78/79, respectively.

After the channel uprights 35, 36, 37 are put in place on the supporting structure, wall or the like, the various background panel members are removably secured thereto simply by attaching these members with their hooklike means, i. e., with their slotted end flanges in engagement with the respective pairs of carrier ledges such as 38, 39 and 40. The background panels 11 and 16 are thus put in position on top of the structure. The panel 11 with its slots 54, 55 in the flange 52 at its left end will engage the carrier ledges formed by the pair of wings 38 on top of the upright 35, and the notches 56/57 in its end flange 53 will similarly engage the carrier ledges 38 of the central or intermediate upright 36. The top background panel 16 is similarly put in place with the notches 54/55 in its rearwardly directed flange 52 at its left end hooked over the carrier ledges 38 of the central or intermediate upright 36, and the notches 56/57 at its right end flange 53 similarly hooked over the carrier ledges 38 of the terminal upright 37 at the right end of the sign.

Each of the downwardly successive panel background members is secured similarly with the notches in the flanges at its opposite ends hooked over the corresponding pairs of carrier ledges on the uprights.

The inner ends of the panel members abut, in the assumed embodiment, in the center of the structure centrally of the central or intermediate upright 36 along the line 21 indicated in Figs. 1 and 2. The pairs of stop ears such as 41/42, 43/44 and 45/46 have no particular function if the upright such as 36 is used in the center of the sign structure or at another intermediate or dividing point. They serve the purpose of preventing the various background panels from slipping off laterally outwardly of the terminal channel members at the opposite ends of the sign. Thus, in the assembled structure, the outer ear 41 at the top of the left end terminal upright 35 prevents slipping off of the panel member 11, thus keeping this panel member in proper position with its right end substantially centrally of the intermediate upright 36; and the outer ear 42 on top of the right hand terminal upright 37 similarly prevents slipping off of the background panel 16, thus keeping this panel in proper position with its inner end in alignment with and abutting the inner end of the background panel 11. The outer ears on each of the terminal uprights 35 and 37 associated with the respective downwardly successive pairs of carrier ledges, such as the stop ears 43-44 and 45-46, keep the corresponding horizontally aligned pairs of panel members similarly in position with their inner ends in alignment and abutment centrally of the intermediate upright 36, preventing the slipping off of these panel members from the structure, thus facilitating assembly of the parts and maintaining the parts in assembled position.

The forwardly protruding ledges 50 extending from the background panel members 11 and 16

5

on top of the structure and the similarly forwardly protruding ledges 72, 73 carried by the bottom panel members 15 and 20, respectively, have the purpose of aligning with the interior parts of the sign and angular border frame or finishing strip having the portions 31, 32 and 33, 34. This border frame may be of a simple angular structure, as particularly shown in Fig. 6, and its respective portions are simply slipped over the ledges 50 and 72-73 formed on top and at the bottom, respectively, by the top and bottom background panels 11-16 and 15-20, respectively. The end members 33, 34 of the border frame are similarly in alignment with the rearwardly directed outer side walls of the terminal channel uprights 35 and 37, respectively. These outer side walls thus form aligning, guiding and mounting means for the end members of the border frame in the same manner as the ledges 50 and 72-73 of the top and bottom panels form a lining, guiding and mounting means for the top and bottom members of the border frame.

If desired, forwardly protruding ears may be punched out from the outside flanges of the channel uprights to form means for guiding the end walls 33, 34 of the border frame into position and for aligning and securing the border frame on the uprights.

In case the uprights are made of flat sheet stock, they may be provided at their edges with ears similar to the ones shown at 41/42, etc., and with similar ears at the ends, for guiding the border frame into position, for aligning it and for securing it thereon.

The background has been shown in two horizontally aligned sections, each section comprising a definite number of vertically successive horizontally extending background panels. It is understood that this has been done only for the purpose of giving an example, as it is entirely possible to make the uprights longer, as long as necessary and practicable, to provide signs of greater height, and similarly to provide more than three uprights, two at the ends of the sign functioning as terminal uprights, as described in connection with the uprights 35 and 37, and several intermediate uprights such as 36, each in back of a dividing line such as 21 where the corresponding intermediate strip-like background panels abut. The background panels may be of standard size, that is, each of similar height and length, and in that case the intermediate uprights will be mounted along center lines which are similarly spaced. The spacing of the terminal uprights at the opposite ends of the structure with respect to the corresponding nearest interior intermediate uprights is slightly different, these spaces being less, in order to fix the panel members at the opposite ends of the structure in position, held by the stop ears such as 41 and 42, etc., projecting from the terminal uprights as described.

The modification shown in Fig. 5 provides uprights such as 80. From the center wall of each such uprights are punched out and rearwardly bent the guide wings such as 81, 82 and 83, thus forming carrier ledges such as 84, 85 and 86. A cutout 87 is formed on top of the upright to provide the carrier ledge 88. There are thus two carrier ledges 88-84 for the background panel 90 on top of the structure and pairs of carrier ledges such as 85/86 for each of the downwardly successive intermediate background panels, one of which is indicated at 91. The top panel 90 has a forwardly projecting ledge 92 and hooklike

6

brackets 93, 94 for mounting engagement with the carrier ledges 88 and 84 on the upright 80. The intermediate background panel 91 is bent angularly forwardly at its top, as indicated at 95, and is provided with similar hooklike brackets 96, 97 for engagement with the carrier ledges 85, 86. The remaining intermediate background panels are constructed just like the ones shown at 91. The bottom background panel (not shown) is constructed similar to the one shown at 15 and 20 in connection with the previously described structure, except that there is no flange such as 74-75 (see Fig. 4), but hooklike brackets at each end of the background panel such as 93/94 and 96/97, respectively, shown in connection with the background panels 90 and 91.

The assembly and operation of the structure shown in Fig. 5 is similar to the one already discussed. The rearwardly directed wings such as 81, 82, 83 in the uprights have an angularly forwardly tilting portion, as shown in Fig. 5, which functions as a guide for the insertion of the corresponding hooklike bracket such as 94 and 96/97, on the respective background panel, and also holds its associated bracket in place after insertion, thus securing the corresponding panel in position. The coaction is wedgelike just as in the case of the carrier ledges with the slotted flanges at the ends of the background panels of the previously described structure. The assembly of the sign is thus facilitated and secured. Separate stop ears such as the ears 41/42, 43/44, 45/46 shown on the uprights of the previous embodiment are not required in the structure of Fig. 5, because the inner edges of the cutouts forming the carrier ledges 88/84 and 85/86 operate as stop and aligning means for the end panels when the uprights are used as terminal uprights.

The embodiment shown in Fig. 7 provides simplified channel uprights each forming a mounting portion 140, a forwardly projecting side wall 141, a front wall 142, and a rearwardly extending flangelike partial side wall 143. On top of the front wall 142 is provided a cutout forming the carrier ledge 144, corresponding to the top carrier ledges 38 and 88, respectively, of the previously described structures. Underneath this cutout is disposed the angular aperture 145 forming the carrier ledge 146 which corresponds to the carrier ledges 38 and 84, respectively, of the previous embodiments. This pair of carrier ledges (144-146) is provided for supporting the hooklike members 147, 148 extending rearwardly from the top background panel 149. Each hooklike member carries a nipple-like extension, as indicated at 150, 151, respectively, for locking the corresponding end of the background panel 149 in engagement with the upright to prevent chattering, e. g., responsive to wind pressure on the panel.

The top panel also carries a forwardly, downwardly and inwardly disposed flange 152 which may be employed to form parts of the frame or border on top of the sign. This flange takes the place of the flanges 50 and 92, respectively, of the top panels 11 and 90 of the structures described before. It will be understood of course that the flanges 50 and 92 of the previous structures may take the form of the flange 152 shown in Fig. 7.

At the bottom, the top panel 149 carries a rearwardly directed drain skirt 153 corresponding to similar skirts in the embodiments described before.

The other, left hand end of the top panel 149

7

is formed just like the right hand end shown in Fig. 7.

The intermediate background panels (not shown in Fig. 7) are alike. Each is structurally similar to the intermediate panels of the previously described sign structure, each forming a forwardly tilted carrier ledge for supporting the various symbols for display, and a downwardly and rearwardly extending drain skirt, as described. The mounting means at each end of each intermediate panel corresponds to the hooklike mounting means 147, 148 described in connection with the top panel 149. Pairs of cutouts or apertures such as 145 are of course provided in each of the uprights for receiving the hooklike mountings of the intermediate panels. Each hooklike mounting member is provided with a nipple, as indicated at 150, 151, to obtain positive wedgelike locking engagement of the corresponding panel with the upright at either end thereof.

The bottom panel 154 corresponds structurally generally to the previously described bottom panels except for the bottom flange 155 which may be used, just like the top flange 152 of the top panel, to form part of the frame, and hooklike mounting means 156, 157 at each end, each having a locking nipple such as 158, 159 for supporting and locking coaction with the carrier ledges 160, 161 of a pair of cutouts 162, 163, respectively. Numeral 164 indicates the angularly forwardly directed member forming the carrier ledge for supporting the symbols for display as before.

Several uprights such as the one shown in Fig. 7 may be suitably mounted on a desired structure, wall or the like, by screws, bolts or nails or the like, which are driven through holes such as 165 provided in the wall 140 of each upright. It should be observed that such screws, bolts, etc. are accessible through the corresponding cutouts such as 145, 162, 163 in the front wall of the upright, facilitating the mounting thereof.

Each of the cutouts such as 145, 162, 163 has a recessed upper portion, as indicated at 145a, 162a, 163a, respectively.

The mounting of the various background panels is accomplished by taking each panel and inserting its pairs of hooklike mounting members, at its opposite ends, into the right hand ends or sides of the corresponding pairs of cutouts in two horizontally successive uprights. The panel is then slightly dropped and moved to the left until the two hooklike members at its left end are in engagement with the left side edge of the cutouts in the corresponding left hand terminal upright (as would be the case with the panel corresponding to panel 11 in Figs. 1-4 and 6) or in alignment with and abutting the right end of the adjacent panel on the left (as would be the case with a panel corresponding to the top panel 16 in Figs. 1-4 and 6). After a panel is put in position in this manner, it is moved downwardly to obtain locking engagement of its hooklike mounting members with the carrier ledges of the cutouts in the corresponding uprights. The panels are then endwise in alignment. All panels are put in position in this manner. The hooklike mounting members of the various panels are accommodated within the left stepped portions of the corresponding cutouts in the uprights. Each panel is positively locked in place at each end thereof.

The flanges 152 of the top panels are in alignment, forming the top portion of the frame. The flanges 155 of the bottom panels are similarly

8

in alignment, forming the bottom portion of the frame. The various forwardly tilting ledges formed by the intermediate panels and by the bottom panel, respectively, are likewise aligned and ready to receive the symbols for display, as already discussed. Suitable border strips may be secured to the sides of the terminal upright at the ends of the sign to complete the frame. If desired, a finishing strip may be put on the aligned top and bottom frame flanges formed by the flange portions 152 and 155 of the top and bottom panels.

Drain holes, as indicated at 170 and 171, may be provided in the frame or flange portions 152 and 155 of the top and bottom panels 149 and 155.

It will be seen from the foregoing explanations that a sign made in accordance with the example shown in Fig. 7 comprises again the elements described in connection with the previous embodiments, the coaction between such elements likewise being similar. The advantages resulting from the structure shown in Fig. 7 reside in utmost structural simplicity, more positive locking action of the panels in engagement with the uprights, and use, if desired, of the top and bottom flanges of the panels to form parts of the frame with or without finishing strips.

The modification shown in Fig. 8 corresponds substantially to the structure shown in Figs. 1-4 and 6 and in Fig. 5, except that it is adapted to accommodate letters or symbols of the so-called "lug" type in which each symbol is provided with one or more lugs at the top and at the bottom, which extend therefrom, for mounting symbols in channel-like adapter members.

Referring now to Fig. 8: Numerals 100, 101 and 103 indicate letters or symbols of the lug type. The lugs of the symbol 100 are indicated at 104/105. Similar lugs 106/107 and 108/109 are carried by the remaining letters or symbols 101 and 103, respectively.

The panel-like background member 110 may be formed just like the panel background member 11 of the previous structure, having a forwardly projecting ledge 111 and an angularly rearwardly directed drain skirt 112. Each of the intermediate background panels 113, 114, 115 is formed generally like the corresponding previously described intermediate panel members, each having a rearwardly directed bottom drain skirt, as indicated at 116, 117 and 118, respectively, and each having an angularly forwardly tilting top portion, as indicated at 119, 120 and 121, respectively. The bottom background panel 122 has on top an angularly forwardly tilting ledge portion 123 and at the bottom a forwardly directed ledge 124. Secured to each of the forwardly tilting top portions of the intermediate and bottom background panels is a cross-sectionally H-shaped double channel member, as indicated at 125, 126, 127 and 128, respectively. The lugs of the various letters or symbols of the lug type are inserted into the channels which face each other; that is, the lugs of the letter or symbol 100 are secured in the channels carried by the channel members 125 and 126, respectively; the lugs of the letter or symbol 101 are removably inserted in the channels formed by the channel members 125 and 127, respectively; and the lugs of the lowermost lug type letter or symbol are similarly inserted in the channels of the channel members 127 and 128, respectively.

The opposite ends of each of the background panel members 110, 113, 114, 115 and 122, respectively, may again be bent rearwardly to form

flanges, and each such flange may be provided with inclined notches for removably mounting the various panels on carrier ledges such as 38, 39, 40 in the channel uprights shown in Figs. 1-4 and 6.

A finishing frame or border may again be provided in the structure shown in Fig. 8, in the same manner as in the previously described structures.

The modification shown in Fig. 9 contemplates background panel members just like the ones shown in Figs. 1-4 and 6, one being shown in section and indicated by numeral 130, carrying on top an angularly forwardly projecting carrier ledge 131 and at the bottom an angularly rearwardly directed drain skirt 132. A slotted mounting flange 133 is provided at each end of the panel for mounting on carrier ledges of uprights in the manner already described. The carrier ledge 131 may thus be used as before, for supporting a symbol of the slotted flange type. Adapter strips such as shown at 134 may be removably secured to the ledges 131 of the various background panels, by suitable means such as clips or screws, for alternatively supporting symbols of the lug type, as shown in Fig. 7. The corresponding sign may thus be quickly adapted for use with either type of symbols.

It has been assumed that there are two hooklike or equivalent mounting members at each end of each background panel member, for coaction with corresponding pairs of mounting or carrier ledges formed on the uprights. The number of such mounting members may of course be more or less, as may be desired.

The use of the cross-sectionally H-shaped channels or adapter members has been described with reference to the embodiment shown in Figs. 1-4 and 6 only for the sake of convenience. It is clear that such channels or adapters may be similarly used with the structure illustrated in Fig. 7.

Changes may be made within the scope and spirit of the accompanying claims in which is defined what is considered new and desired to have protected by Letters Patent of the United States.

We claim:

1. A changeable display sign of the class described comprising a pair of upright terminal mounting members disposed on a suitable supporting structure in generally vertical position one substantially at each end of the sign, at least one intermediate upright mounting member disposed on said supporting structure at a point between said terminal mounting members and extending in parallel therewith, means integral with each mounting member forming a plurality of vertically successive pairs of carrier ledges thereon, each pair of carrier ledges of each mounting member being disposed in horizontal alignment with a corresponding pair of carrier ledges on the other mounting members, a plurality of pairs of background panels, and a pair of securing means carried by each background panel at each end thereof and rearwardly extending therefrom for removable engagement with corresponding pairs of said carrier ledges on said mounting members to position each pair of background panels in end-to-end assembly with said mounting members, the top portions of said background panels tilting angularly forwardly to form carrier means for removably supporting symbols in engagement therewith.

2. The sign structure as set forth in claim 1, together with means formed on said mounting members for determining the end-to-end position of each pair of said background panels thereon.

3. The sign structure as set forth in claim 1, together with channel means carried by the top portions of said background panels to form the carrier means for removably supporting symbols in engagement therewith.

4. In a changeable sign of the class described, a vertically extending terminal mounting member disposed substantially at each end of the sign, an intermediate vertically extending mounting member of identical structure disposed between said terminal mounting members in parallel therewith, carrier means on each mounting member integral therewith, a pair of panel members each having hooklike means at each end thereof for removable engagement with the carrier means on said mounting members to position said panel members thereon in horizontal alignment, and stop means carried by said mounting members integral therewith for engagement with said panel members to keep the inner ends thereof in abutment and the outer ends against displacement relative to said terminal mounting members.

5. A changeable sign of the class described comprising a plurality of elongated upright mounting members for disposal in horizontally spaced generally parallel relationship on a wall or the like, pairs of longitudinally spaced ledge means formed on said mounting members integral therewith, a plurality of background panel members removably mounted on said ledge means to form horizontally aligned vertically successive background panel sections, the upper edge of each but the top panel member being tilted to extend angularly forwardly and upwardly to form a carrier ledge for removably supporting symbols thereon to form a message and the lower edge of each but the bottom panel being tilted to extend angularly rearwardly to form with the forwardly tilted upper edge of the adjacent panel member a rearwardly directed channel for draining moisture from the sign, the top portion of the top panel member and the bottom portion of the bottom panel member extending forwardly to form at the top and bottom of said sign horizontally abutting border members.

6. A changeable sign of the class described comprising a pair of upright terminal mounting members disposed in generally vertical position one at each end of the sign, at least one intermediate upright mounting member disposed at a point between said terminal upright mounting members and extending in parallel therewith, each upright mounting member being alike and forming a plurality of vertically successive pairs of horizontally extending carrier ledges and a pair of stop members associated with each pair of carrier ledges, a plurality of panel members each forming rearwardly directed hook means at either end thereof, said panel members being removably secured to said pairs of carrier ledges by engagement of their hook means with such ledges to form horizontally contiguous vertically successive background sections, the upper portion of each but the topmost panel members forming angularly forwardly disposed carrier means for removably supporting symbols thereon and the bottom portion of each but the lowermost panel member forming an angularly rearwardly tilting skirt to form with the forwardly disposed carrier means of the adjacent panel member a rearwardly tilting channel for downwardly draining moisture from the corresponding portion of the sign, said stop members being operative to maintain horizontally successive panel members in

alignment with the inner ends thereof in abutment and holding the outermost panel sections against displacement relative to the corresponding terminal upright mounting members, the topmost and the lowermost panel members forming forwardly projecting mounting ledges, and means forming a border frame secured to said mounting ledges.

7. The sign structure as set forth in claim 6, wherein said carrier ledges are formed on said upright mounting members by sections which are integral therewith and displaced angularly relative to the general plane thereof, said displaced sections being also operative to guide the insertion of said carrier ledges into the corresponding hook means formed at the ends of said panel members.

8. The sign structure as set forth in claim 6, together with flanges formed on said panel members, one at each end thereof, and notches formed in said flanges to form said hook means.

9. The sign structure as set forth in claim 6, together with channel means carried by the upper portion of each but the topmost panel members to form the carrier means for removably supporting symbols.

10. The sign structure as set forth in claim 6, together with means carried by said upright mounting members for mounting said border frame.

11. A changeable sign of the class described comprising a pair of horizontally spaced vertically extending uprights, each upright being cross-sectionally generally U-shaped to form with one leg thereof a rear wall for attachment to a supporting structure and with the other leg thereof a front wall spaced from said rear wall, longitudinally stepped cutouts formed in said front wall, each cutout having a relatively narrow top section and a wider bottom section downwardly extending therefrom, the bottom edge of the bottom section of each cutout forming a mounting ledge, a plurality of background panels, each panel having rearwardly directed hook-like means for insertion into one of said cutouts and for mounting engagement with the corresponding mounting ledge thereof, said hooklike means being insertable into and removable from its associated stepped cutout only along the entire length of such cutout including the narrow and the wider section thereof and being in mounted position disposed in said wider portion of said cutout in relatively fixed relation therewith, and angularly forwardly directed flangelike display means carried by each background panel.

12. A changeable sign of the class described comprising a plurality of structurally substantially identical generally cross-sectionally rectangular generally vertically disposed horizontally spaced channel-shaped upright mounting members, each mounting member having a rear wall for attachment to suitable supporting means and a front wall spaced from said rear wall, a longitudinally extending cutout formed in the front wall of each upright mounting member, each cutout having at one end thereof a stepped configuration to form an elongated slotlike opening having a relatively short portion adjacent a relatively long portion, the other end of each cutout forming a mounting ledge, a background panel forming a display surface for disposal between said upright mounting members and hav-

ing a hooklike member rearwardly extending therefrom at each end thereof for removable attachment to the mounting ledge formed by the cutouts in the correspondingly disposed upright mounting members, the length of each hooklike member corresponding substantially to the length of the relatively long portion of the cutout in its associated upright mounting member, whereby said background panel can be removably mounted on said uprights by insertion of its hooklike members through the relatively long portions of the cutouts therein and locked against inadvertent displacement with respect to said upright by disposal thereof sideways relative to said uprights to position said hooklike members within the relatively short portions of said cutouts.

13. A changeable display sign of the class described comprising means forming a plurality of horizontally extending vertically successive pairs of carrier ledges, each pair of ledges for removably supporting symbols each of which consists of a symbol body having rearwardly extending flanges and notches in said flanges for engagement with the corresponding pair of carrier ledges, and adapter means for removable attachment to each pair of carrier ledges to form thereon horizontally extending vertically directed channels for removably supporting symbols each of which consists of a symbol body and luglike extensions projecting therefrom for insertion into said channels, said luglike extensions projecting from the corresponding symbol body in a plane which generally parallels the plane of the face thereof.

14. For use in a changeable display sign having at least two pairs of horizontally extending vertically spaced barlike members, each pair forming two carrier ledges for supporting letters to be displayed thereon each of which has rearwardly directed flanges with notches formed therein for hooklike engagement with said carrier ledges, an adapter for removable attachment to each pair of said carrier ledges, said adapter consisting of a holder comprising a horizontally extending panel member, flanges rearwardly extending from said panel member which are slotted for hooklike engagement with said carrier ledges, and a cross-sectional H-shaped strip on said panel member extending along one edge thereof, said cross-sectionally H-shaped strip forming in mounted position of said panel member on said carrier ledges vertically directed horizontally extending channels for removably supporting in front of said panel member different letters each comprising a symbol body and a luglike extension projecting therefrom generally in parallel with the face thereof for insertion into a channel formed by said cross-sectionally H-shaped strip.

ERWIN WAGNER.
WALTER S. WAGNER.

REFERENCES CITED

The following references are of record in the file of this patent:

UNITED STATES PATENTS

Number	Name	Date
2,009,262	Hetherington	July 23, 1935
2,224,069	Wagner	Dec. 3, 1940
2,230,873	Wagner	Feb. 4, 1941