

(12) UK Patent Application (19) GB (11) 2 131 849 A

- (21) Application No **8333419**
(22) Date of filing **15 Dec 1983**
(30) Priority data
(31) **57/219748**
(32) **15 Dec 1982**
(33) **Japan (JP)**
(43) Application published
27 Jun 1984
(51) **INT CL³**
E04C 3/08
(52) Domestic classification
E1D 2103 2105 402 547
LEBD
(56) Documents cited
GB 1080742
GB 1006324
GB 0490297
GB 0318164
GB 0234035
(58) Field of search
E1D
(71) Applicant
Kajima Kensetsu
Kabushiki Kaisha,
(Japan),
1—2—7 Motoakasaka,
Minato-Ku,
Tokyo,
Japan
(72) Inventors
Kuniaki Sato,
Yoshinori Toyota,
Masahiro Koyama
(74) Agent and/or address for
service
Stanley Popplewell Poole,
57 Lincoln's Inn Fields,
London,
WC2A 3LS

(54) **Structural framework**

(57) A structural framework has a built-up column 1 having a plurality of girders which be of I- or H-section or latticed or trussed so as to have webs

in parallel and coupled with a connecting member 3 to provide a gap between flanges of adjacent girders, the built-up column 1 and a beam 2 being joined together with brackets 5.

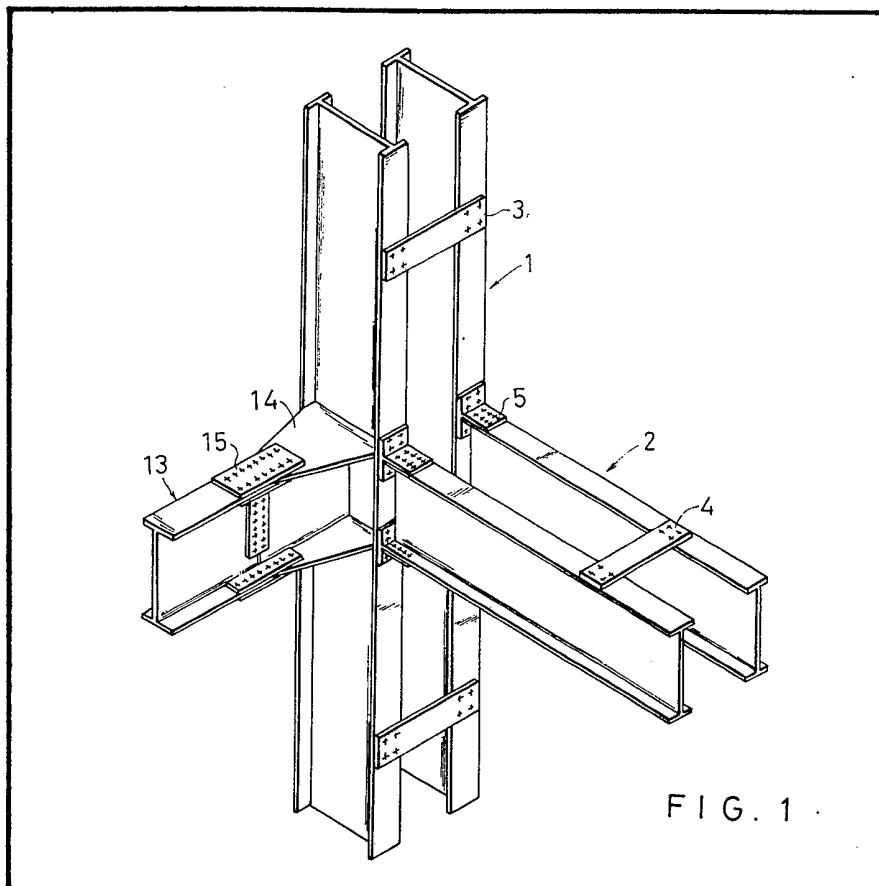

GB 2 131 849 A

FIG. 1

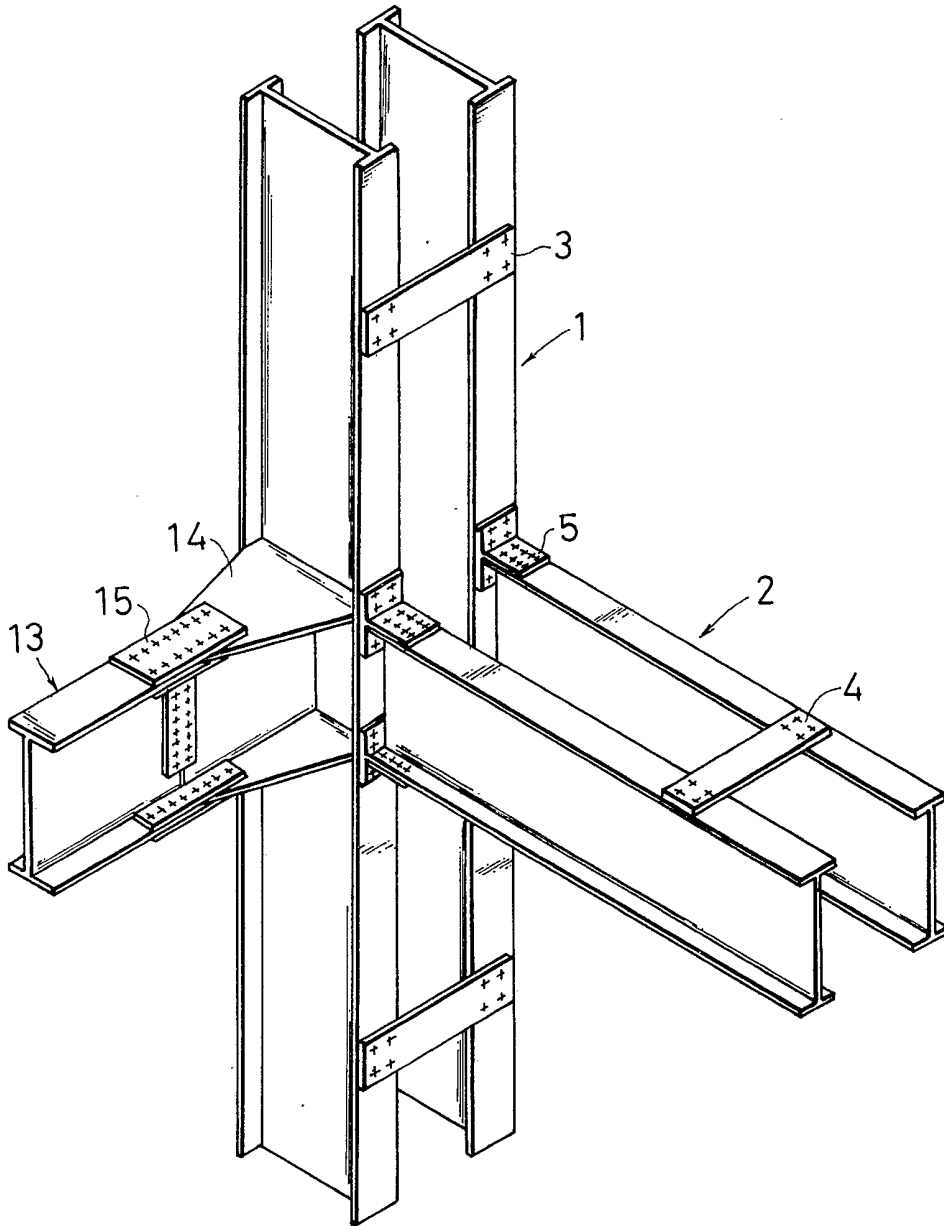

FIG. 2

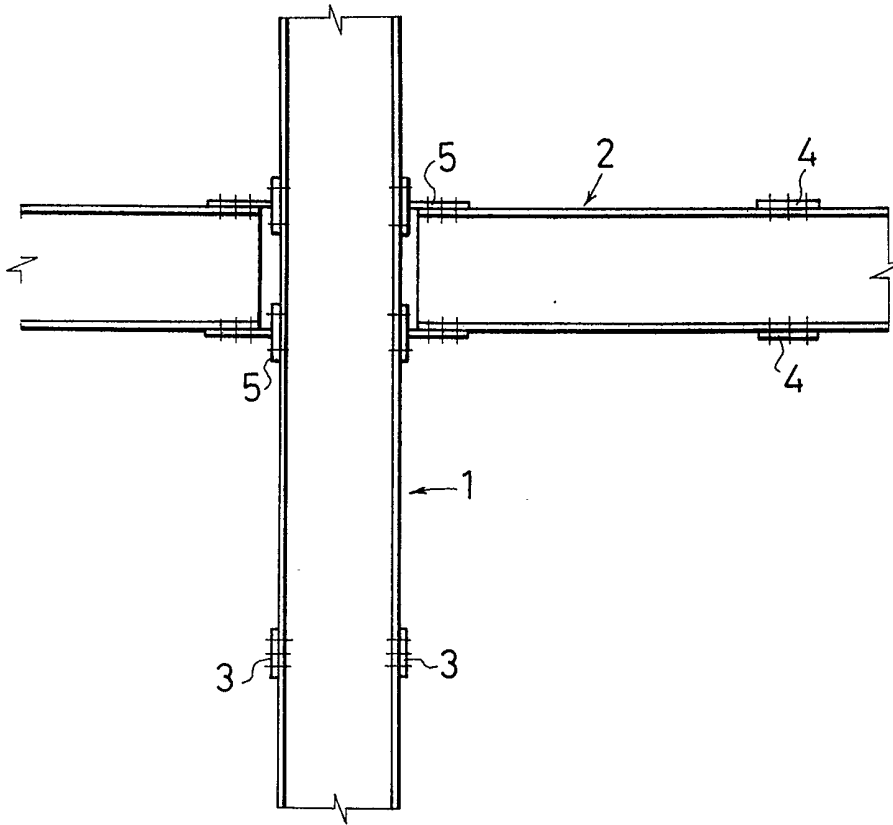

FIG. 3

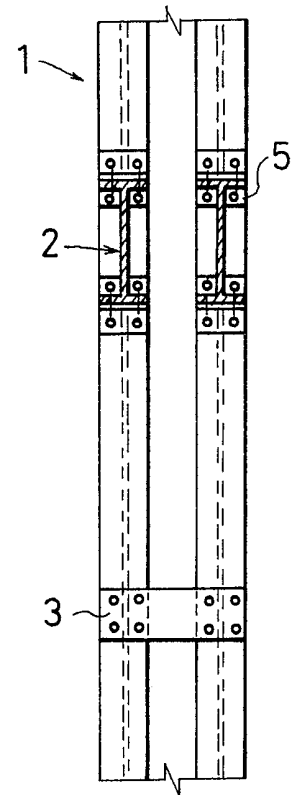

FIG. 4

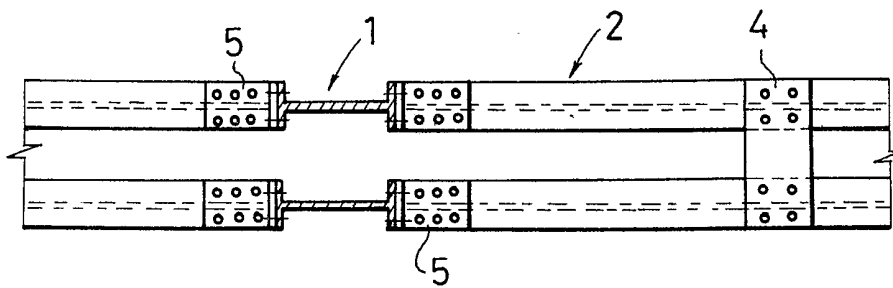

FIG. 5

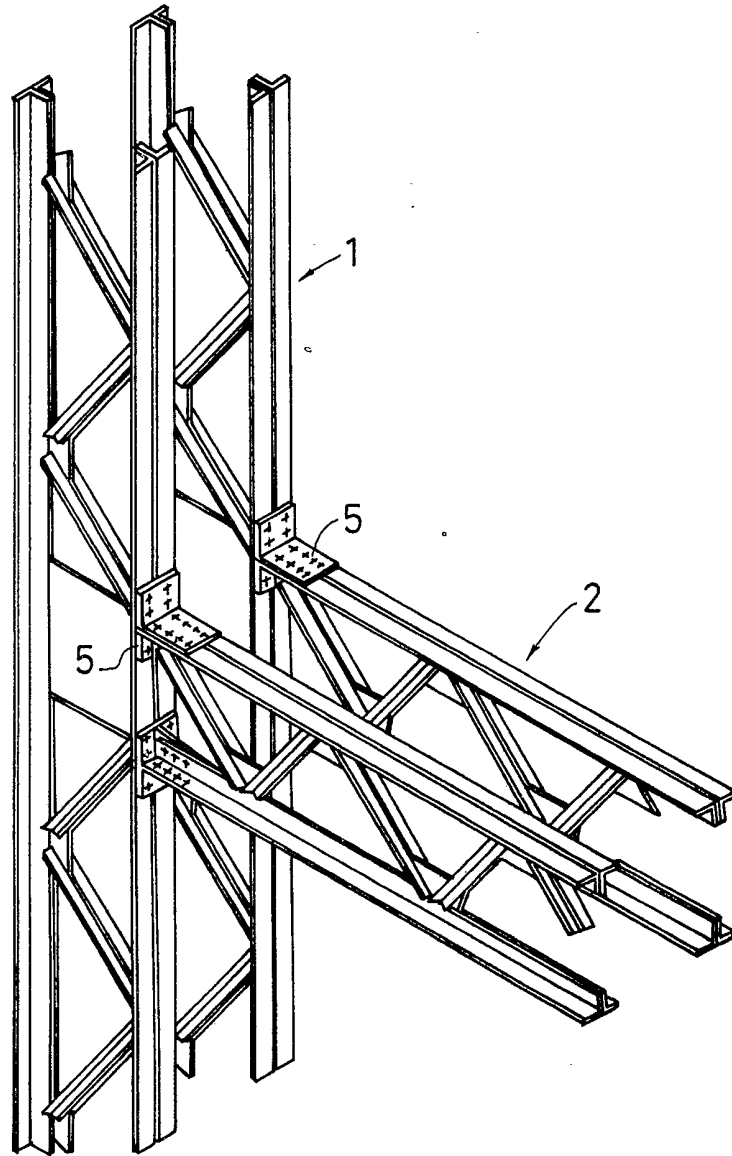

FIG. 6

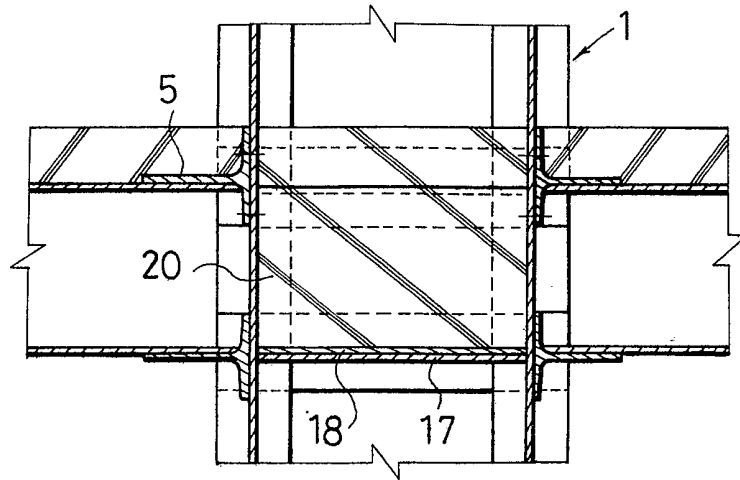

FIG. 7

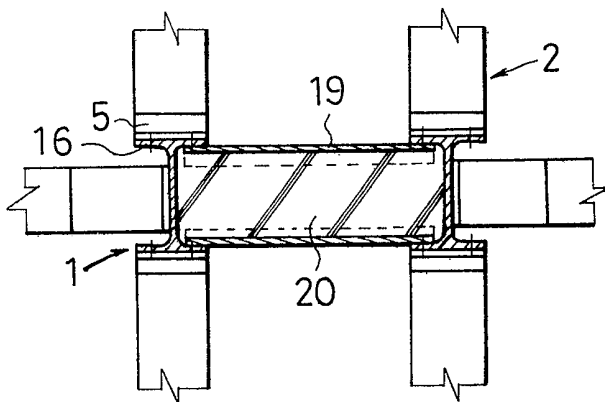

FIG. 8

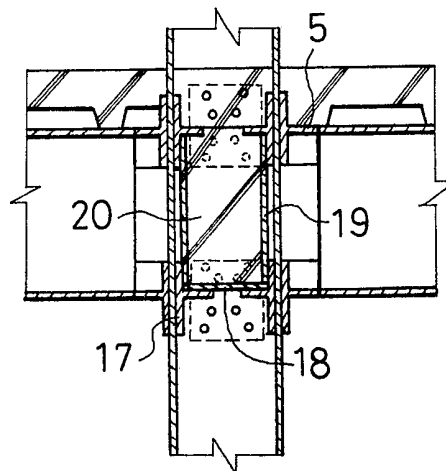

FIG. 9

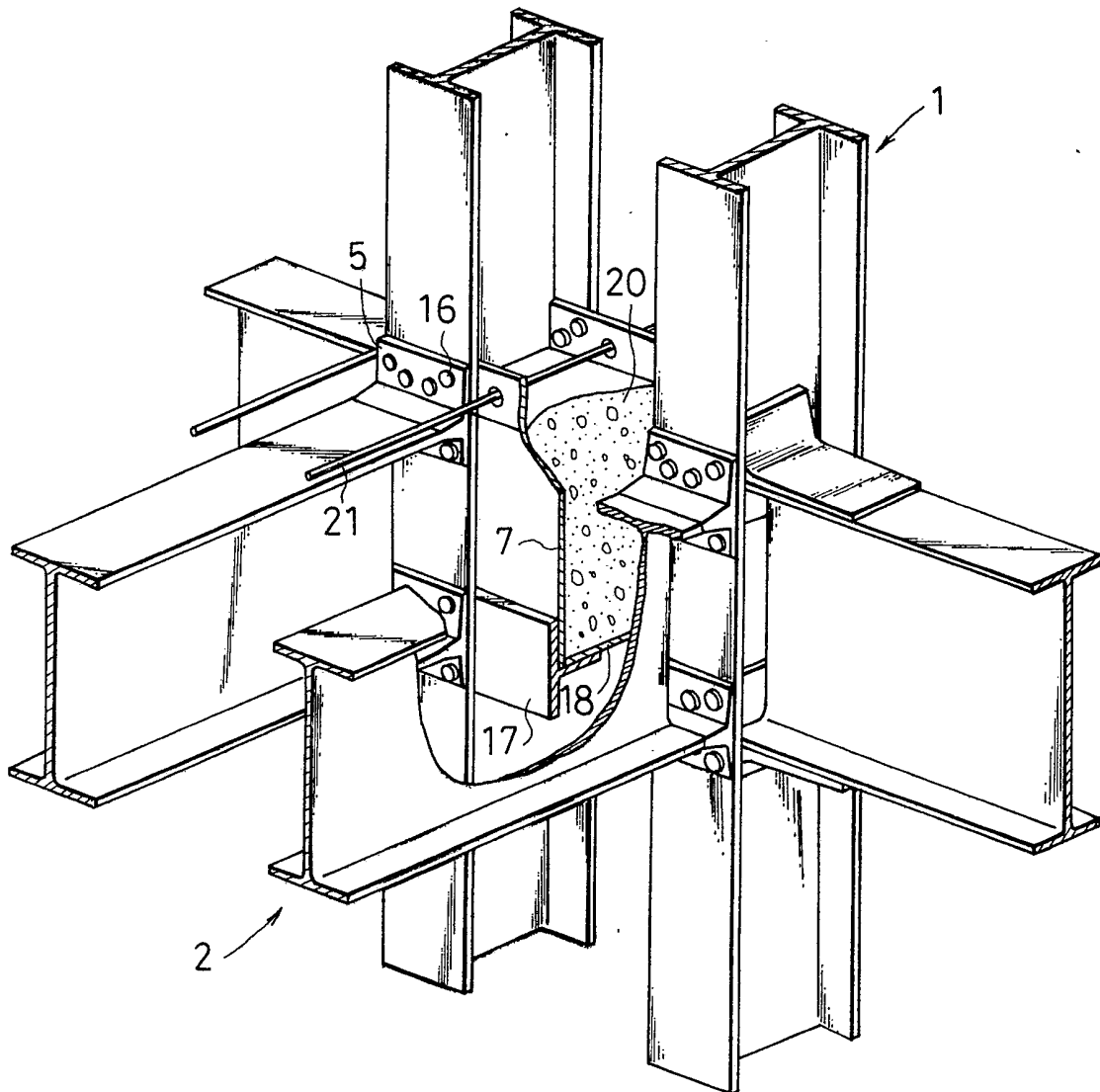

FIG.10

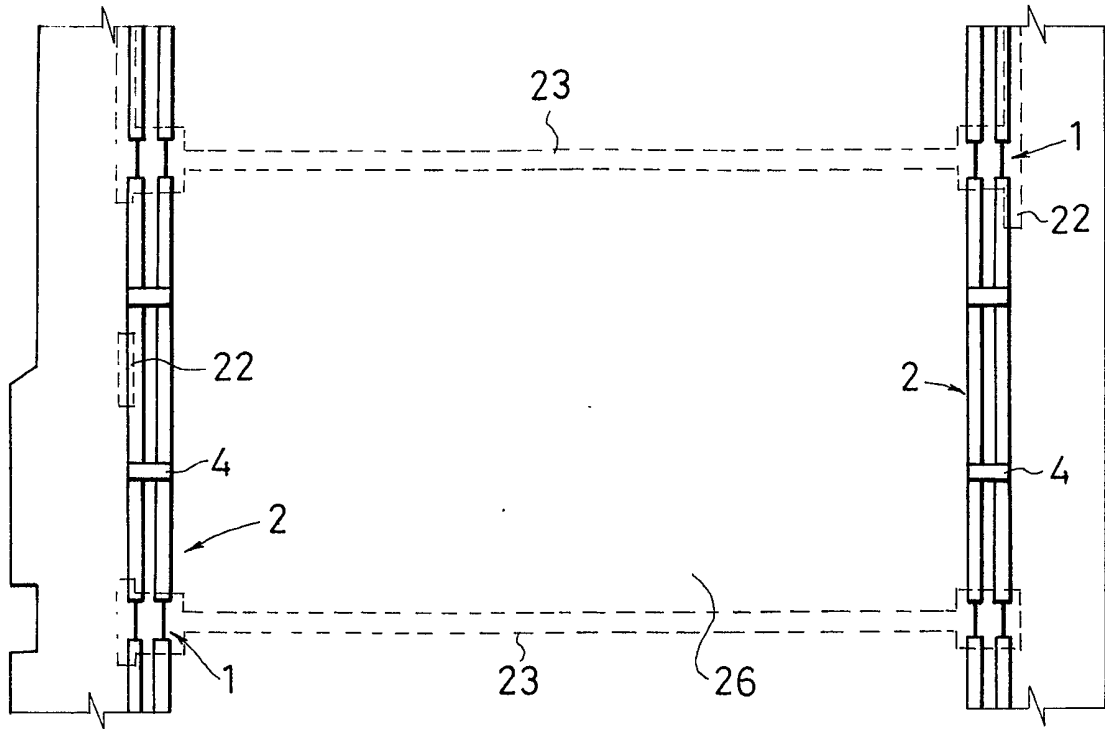

FIG.11

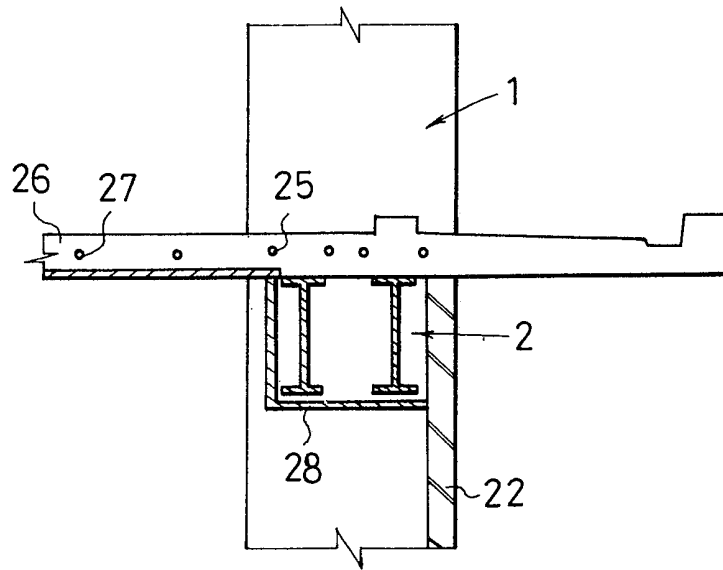

FIG. 12

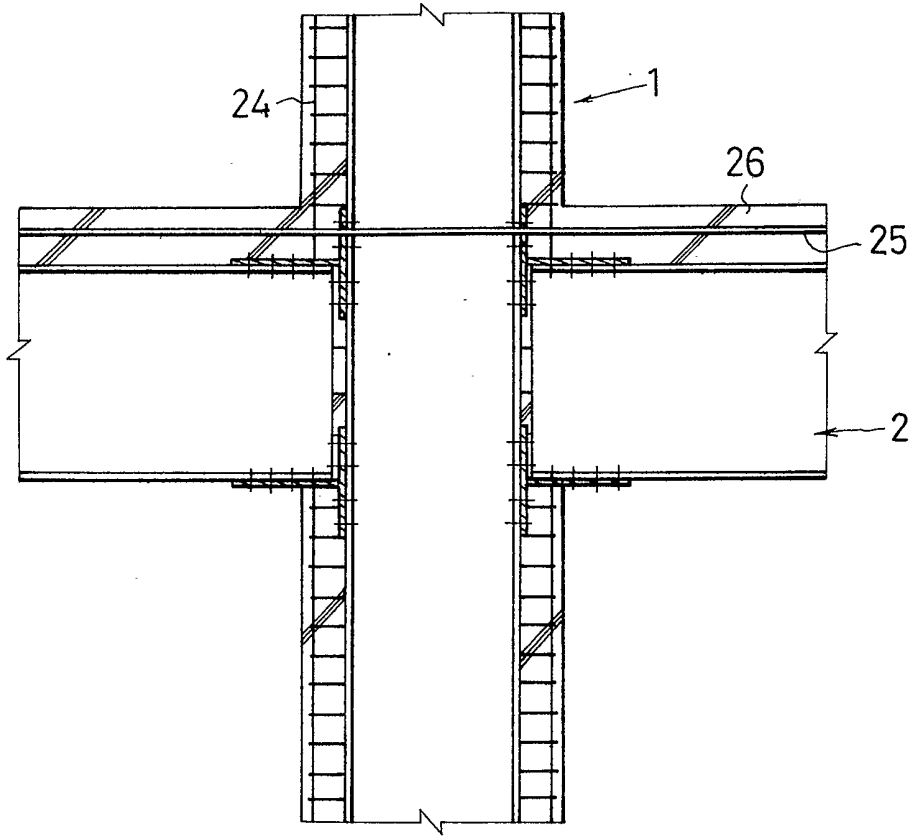

FIG. 13

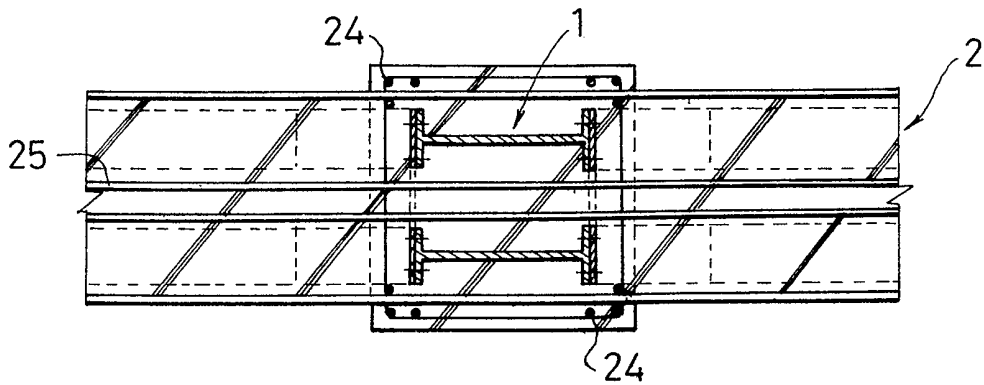

FIG. 14

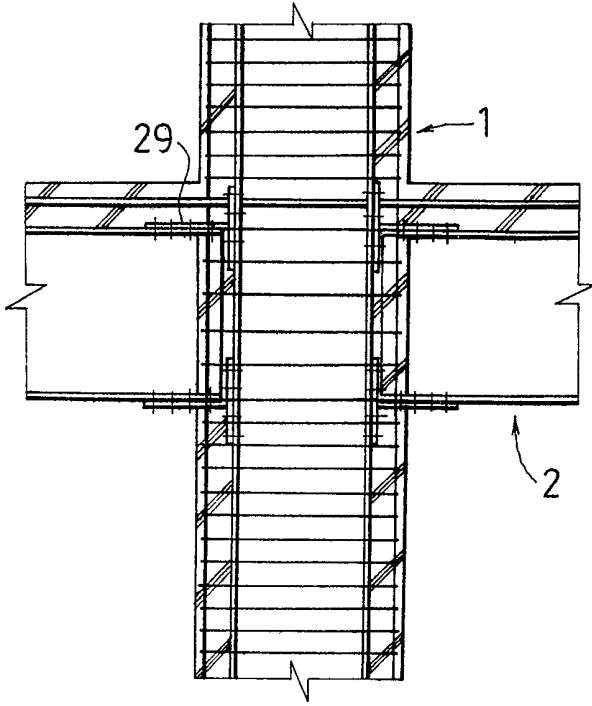

FIG. 16

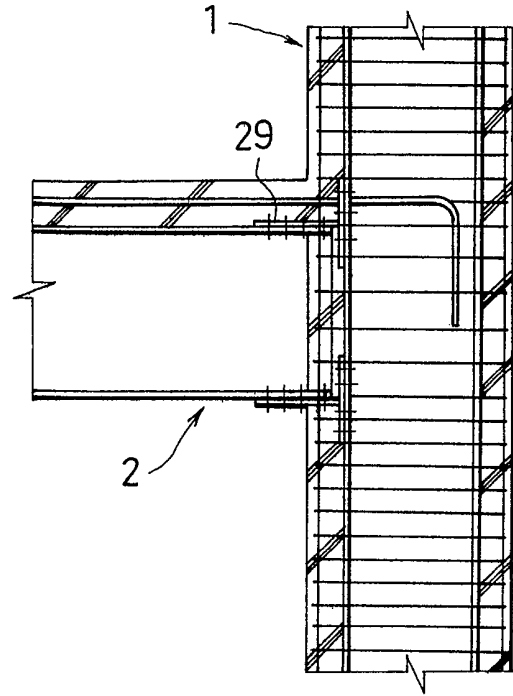

FIG. 15

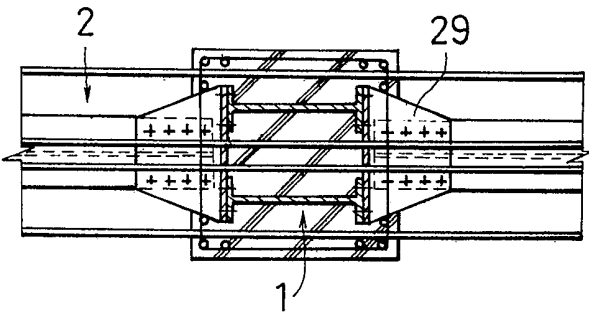

FIG. 17

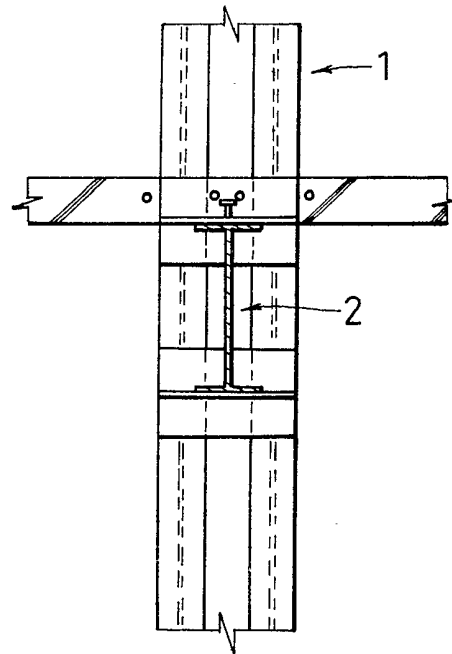

FIG. 18

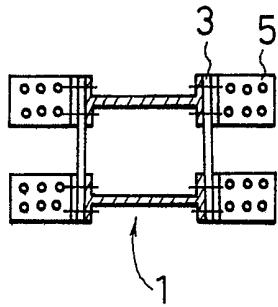

FIG. 19

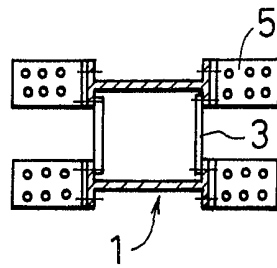

FIG. 20

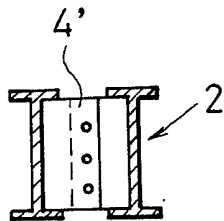

FIG. 21

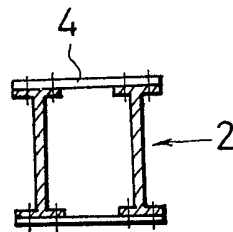

FIG. 22

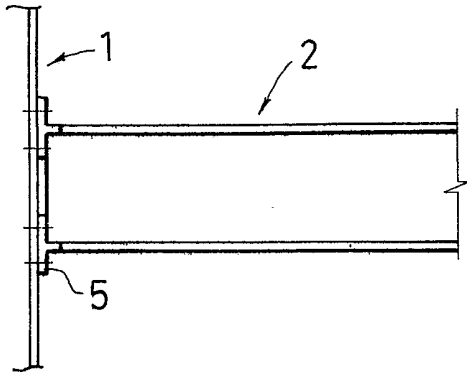

FIG. 23

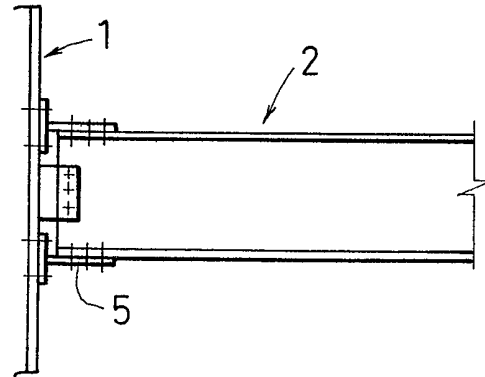

FIG. 24

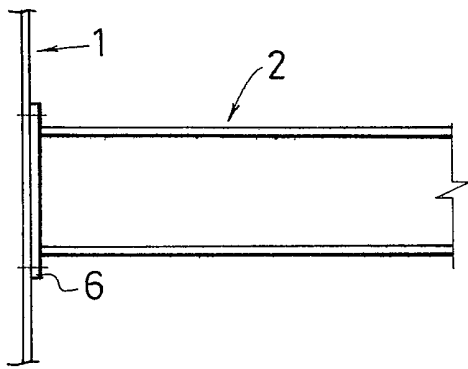

FIG. 25

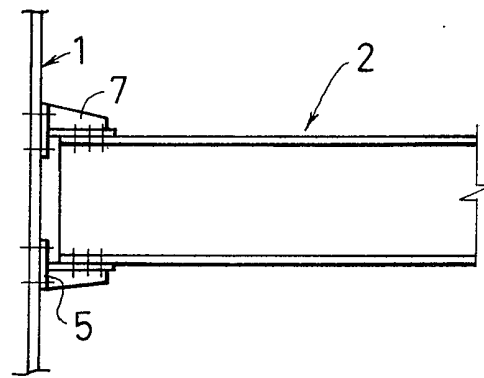

FIG. 26

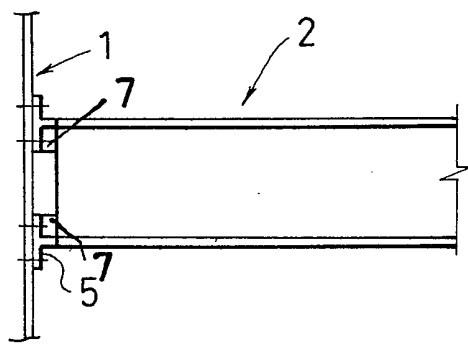

FIG. 27

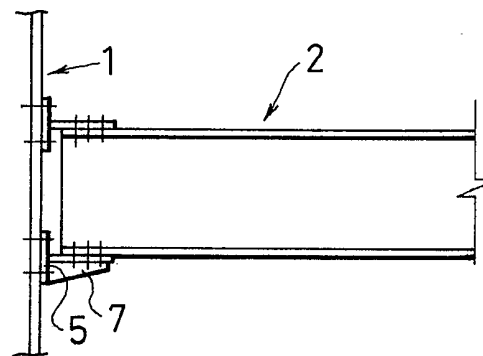

FIG. 28

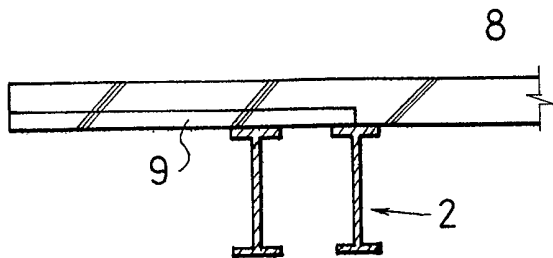

FIG. 29

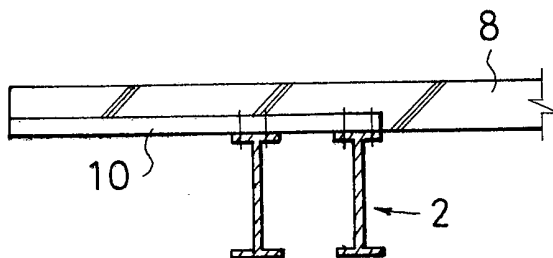

FIG. 30

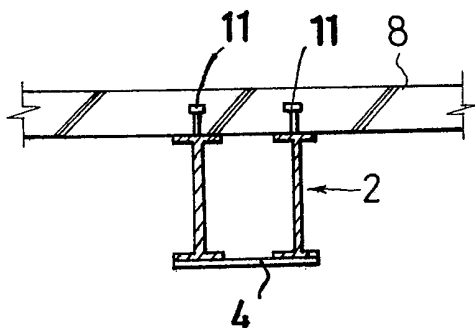
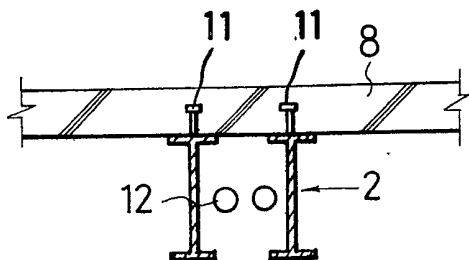

FIG. 31.



SPECIFICATION

Structural framework

This invention relates to a girder framework for civil engineering and building structures.

- 5 A high-strength bolt tensile junction using a T-shaped bracket for forming a column and a beam of a frame construction has been appreciated hitherto in respect of labour saving for frame shop working and better efficiency for site execution.
- 10 However, in such a frame the number of tension bolts is limited by the size of the girder and brackets and the weakness caused by the bolt-holes.

- An object of this invention is to make the most of advantages of the high-strength bolt tensile junction, thereby solving problems of yield strength, and also to increase the degrees of freedom in planning of buildings, thereby improving workability.

- 15 The invention is set out in claim 1 of the claims of this specification.

Examples of the invention will now be described with reference to the accompanying drawings, in which:

- 25 Fig. 1 is a perspective view of a framework given in one embodiment of this invention;
Fig. 2, Fig. 3 and Fig. 4 are a front view, a longitudinal sectional view and a transverse sectional view, respectively, of the embodiment given in Fig. 1;
- 30 Fig. 5 is a perspective view representing a variant;
Fig. 6, Fig. 7, Fig. 8 and Fig. 9 are a longitudinal sectional view, a transverse sectional view, a longitudinal sectional view and a perspective view, respectively, representing another embodiment of the invention;
- 35 Fig. 10, Fig. 11, Fig. 12 and Fig. 13 are a schematic transverse sectional view when applied to a multi-storey dwelling house, a longitudinal sectional view of beam and floor, a longitudinal sectional view of column and beam and a transverse sectional view thereof;
- 40 Fig. 14 is a vertical sectional view of a different embodiment;
Fig. 15 is a cross-sectional view of the embodiment shown in Fig. 14;
Fig. 16 is a vertical sectional view taken at the position of the outer column;
- 50 Fig. 17 is a vertical sectional view in the assembled state of the frame;
Fig. 18 and Fig. 19 are transverse sectional views representing a variant of built-up column section;
- 55 Fig. 20 and Fig. 21 are longitudinal sectional views of built-up beam section;
Fig. 22 to 27 are front views representing variants of the junction of built-up column and built-up column and built-up beam; and
- 60 Fig. 28 to Fig. 31 are longitudinal sectional views of beam and slab variants.

Figure 1 illustrates part of a framework including a built-up column 1 and a beam 2 connected to each other by connecting brackets

- 65 5. The built-up column 1 is an I- or H-steel sectional girder consisting of flanges and a web. The column may be a latticed column as shown in Fig. 5. The webs of the girders are parallel to each other, with a gap provided between the flanges, and the flanges are coupled with a joint member 3 of flat steel. The joint member 3 then works as a reinforcement for the column flange at the same time. In this embodiment, in one direction, the beam 2 is constructed as a built-up beam 2. The built-up beam has girders of H-section disposed in parallel at the same spacing as the built-up column 1 and the flanges are coupled by a joint member 4.

- For joining the built-up column 1 and the built-up beam 2, split tee brackets with high-strength bolts are used. Various examples of joints are given in Fig. 22 to Fig. 27. In the case of Fig. 22, bolt holes are perforated beforehand in the stem of a T-shaped bracket 5 and the flange of the built-up column 1, and the bracket 5 is fixed on the built-up column 1 by means of high-strength bolts through holes. The cross-piece of the bracket 5 is welded directly on the flange of the built-up beam 2. As shown in Fig. 23, the stem of the bracket can be placed upon the flange of the built-up beam 2 and then joined with high-strength bolts. An end plate 6 of the built-up beam 2 can be joined to the flange of the built-up column 1 with high-strength bolts as shown in Fig. 24. Further a reinforcing rib 7 can be provided on the bracket 5 as illustrated in Fig. 25 to Fig. 27.

- Fig. 28 to Fig. 31 illustrate a case wherein a reinforced concrete slab 8 is cast in situ on the built-up beam 2. A deck plate 9 or a thin pre-cast concrete panel 10 is used to support an open-sided slab portion. A shear connector 11 can be fixed on the flange of the built-up beam 2. Piping 12 or wiring can be arranged in a space of the built-up beam 2.

- As shown in Fig. 1 a horizontal stiffener 14 is welded to the H-section girder web for joining a beam 13 transversely of the built-up column 1, which is joined with high-strength bolts by means of joint plates 15. Alternatively, the horizontal stiffener 14 can be welded directly to a flange of the beam 13.

- When the built-up column and the built-up beam are assembled with the T-shaped brackets, it is necessary that the high-strength bolts be inserted from inside the column flange. A suitable size of gap will have to be made between columns of the built-up column. However, when the frame is subjected to a horizontal force with the gap existing as above, there is a greater chance of deformation, which is problematical.

- The embodiments of Fig. 6 to Fig. 9 are designed to improve a rigidity of the structure, thereby minimizing deformation in the steel frame.

- 125 The built-up column 1 and the built-up beam 2 both have H-shaped members formed together at suitable intervals, and the built-up column 1 and the built-up beam 2 are joined together through

bolting and welding by the T-shaped brackets 5. The T-shaped brackets 5 is joined to the built-up column 1 with bolts 16, and the built-up beam 2 is butt-welded on the T-shaped bracket 5. Then, a bearing member 17 T-shaped in section is mounted on the inside of the flange of the built-up column 1, an iron base plate 18 and an iron side plate 19 are mounted on the bearing member 17, and after possible bolting concrete 20 is poured into the space surrounded by the built-up column 1, the base plate 18 and the side plate 19 to give rigidity to the structure. A through hole is provided on the upper part of the side plate 19 to accommodate a beam reinforcement 21 therein.

Since there is a gap present between girders of the built-up column 1, the T-shaped brackets 5 can be fixed in position with the high-strength bolts.

The embodiments of Fig. 10 to Fig. 13

illustrate the invention applied to a multi-storey dwelling house.

The built-up column 1 and the built-up beam 2 used in the building structure are those for which two girders of H-section are disposed with their webs in parallel and the necessary gap provided between the flanges and then assembled with a joint member as described above.

The built-up column 1 is installed on the slab concrete at the desired position. In this case, each built-up column 1 is arranged so as to have the webs of the H-steel parallel.

Then, the T-shaped brackets 5 are mounted on the flanges of each built-up column 1 with high-strength bolts and the built-up beam 2 is welded or joined with high-strength bolts extending parallel to the webs of the girders of the built-up column 1 by the T-shaped brackets 5 (which is the strong direction of the girders of column 1).

A pre-cast wall panel 22 is built in the outer wall. A cast-in-place reinforced concrete wall 23 is provided in the weak axial direction of the girder acting as an interior boundary wall. In this case, a connecting member consisting of a small frame section which connects adjacent built-up columns 1 in the weak axial direction is embedded in the wall 23. A column reinforcement 24 and a beam reinforcement 25 are arranged around the built-up column and the built-up beam, and concrete is poured to include the column in a steel-framed reinforced concrete structure and the beam in a composite beam.

A floor 26 is framed with a large slab of cast-in-place reinforced concrete without a binder, and a deflection of the floor is controlled by means of an unbonded steel wire 27. A fireproof coating 28 is applied on the side and lower parts of the built-up beam 2.

In a different embodiment shown in Figs. 14 to 17, only the column 1 is constructed as a built-up column 1 consisting of a pair of H-section girders while the beam 2 is constituted by a single H-section girder. A bracket 29 serving as a connecting member is jointed to both girders of the built-up column 1 through high-strength bolts so as to connect the beam 2. Fig. 16 illustrates

the construction at the peripheral part of the building.

The advantages of the invention can be seen from the following considerations:

- 70 (1) A bending strength of the column and the beam through a high-strength bolt tensile junction is governed by the number of working tension bolts. The number of tension bolts is limited to 4—8 per H-shaped column according to the width of the flange, however, it can be increased to 8—16 by arranging the present built-up column, to which may also be added a built-up beam. The bending strength can therefore be doubled.
- 75 (2) A single H-section girder has small resistance to buckling in the weak axial direction. However, the built-up column is very effective in increasing the resistance to buckling in the weak axial direction.
- 80 (3) A permissible bending stress of the beam depends on the lateral buckling of the beam, but the built-up beam is more resistant to lateral buckling, which is very effective in increasing resistance to bending stress.
- 85 (4) A combination of the built-up column and the built-up beam may improve the yield strength of the frame as mentioned above. Therefore, columns can be installed with larger than normal intervals between them, giving an increased degree of freedom for planning.
- 90 (5) The frame is composed of relatively large members, and a junction of the column and the beam is made only with the joint brackets and high-strength bolts, thus improving efficiency.
- 95 (6) When the built-up beam is located along the circumference of a building, a deck plate can be cantilevered from the built-up beam and concrete is placed thereon to form an open-sided slab without using a scaffold.
- 100 (7) The internal space of the column and the beam can be used effectively by including pipes and wiring in the space between the girders of the built-up column and the built-up beam.
- 105
- 110

Claims

- 115 1. A structural framework composed of a built-up column and a beam joined to the built-up column through a bracket, said built-up column having a plurality of girders with webs and flanges with their webs parallel, and then coupled with a connecting member to leave a gap provided between the flanges of adjacent girders.
- 120 2. The structural framework as defined in Claim 1, wherein the girders are I- or H-sectioned.
3. The structural framework as defined in Claim 1, wherein the girders are latticed or trussed.
- 125 4. The structural framework according to claim 1, wherein said beam is a built-up beam composed of a plurality of I- or H-sectioned girders each having a web and a flange or flanges,

said girders being laid such that their flanges extend horizontally with a gap left between the flanges of the adjacent girders and connected by connecting members.

5 5. The structural framework as claimed in any one of Claims 1 to 4, wherein the bracket is T-shaped.

10 6. The structural framework as claimed in any one of Claims 1 to 5, wherein concrete is filled into the built-up column at a junction of the built-up column and the built-up beam.

7. The structural framework as claimed in any

one of Claims 1 to 6, wherein reinforcing bars are arranged around the built-up column, a beam reinforcement is arranged through said gap of the built-up column and concrete is poured at the junction to form a steel-framed reinforced concrete structure.

20 8. A structural framework substantially as herein described with reference to and as illustrated in Figures 1 to 4 or Figure 5 or Figures 6 to 9 or Figures 10 to 13 or Figures 14 to 17 alone or as modified by any of Figures 18 to 31 of the accompanying drawings.