

No. 729,253.

PATENTED MAY 26, 1903.

A. BARR, W. STROUD & L. BECKER.

PAWL AND RATCHET MECHANISM FOR ELECTRIC CLOCKS.

APPLICATION FILED FEB. 5, 1901.

NO MODEL.

4 SHEETS—SHEET 1.

*Fig. 1a*

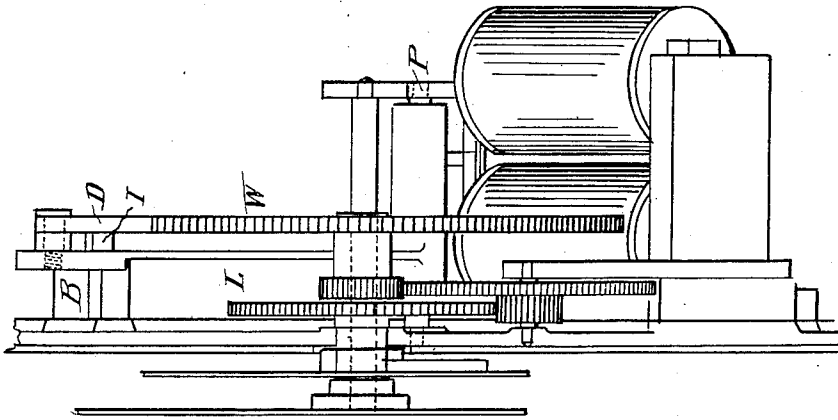

*Fig. 1.*

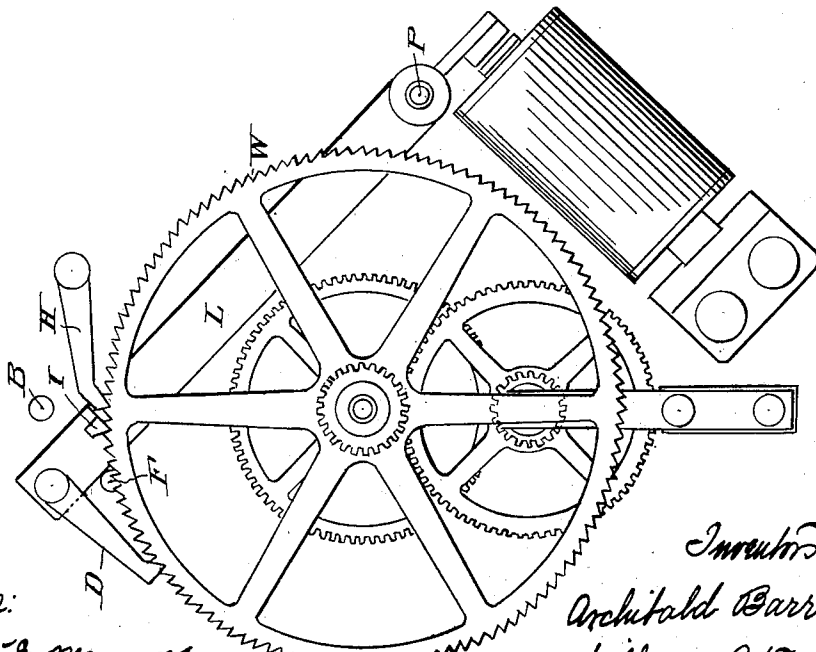

*Witnesses:*  
*Karl Herrm & Manning*  
*Just A Adams*

*Ludwig Becker*

*Inventors:*  
*Archibald Barr,*  
*William Stroud,*  
*By Lyth Knight Esq.*  
*attys.*

No. 729,253.

PATENTED MAY 26, 1903.

A. BARR, W. STROUD & L. BECKER.

PAWL AND RATCHET MECHANISM FOR ELECTRIC CLOCKS.

APPLICATION FILED FEB. 5, 1901.

NO MODEL.

4 SHEETS—SHEET 2.

*Fig. 1a*

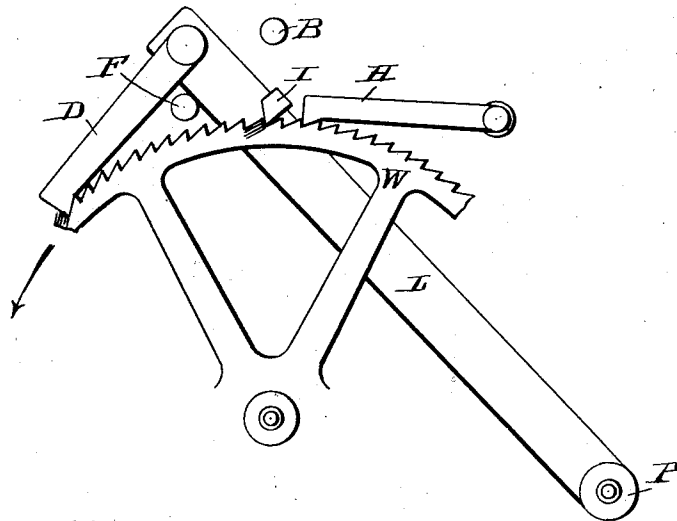

*Fig. 1b*

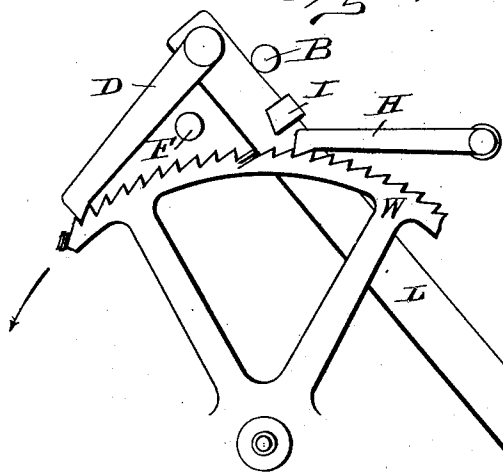

*Fig. 1c*

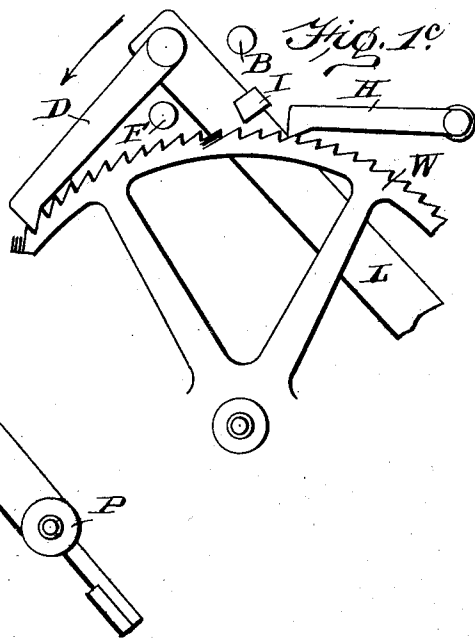

Inventors

*Archibald Barr*

*Ludwig Becker, William Stroud*

*Thight Bros*

Attorneys

Witnesses

*H. G. Dieterich*  
*Harold Lund*

A. BARR, W. STROUD & L. BECKER.

PAWL AND RATCHET MECHANISM FOR ELECTRIC CLOCKS.

APPLICATION FILED FEB. 5, 1901.

NO MODEL.

4 SHEETS—SHEET 3.

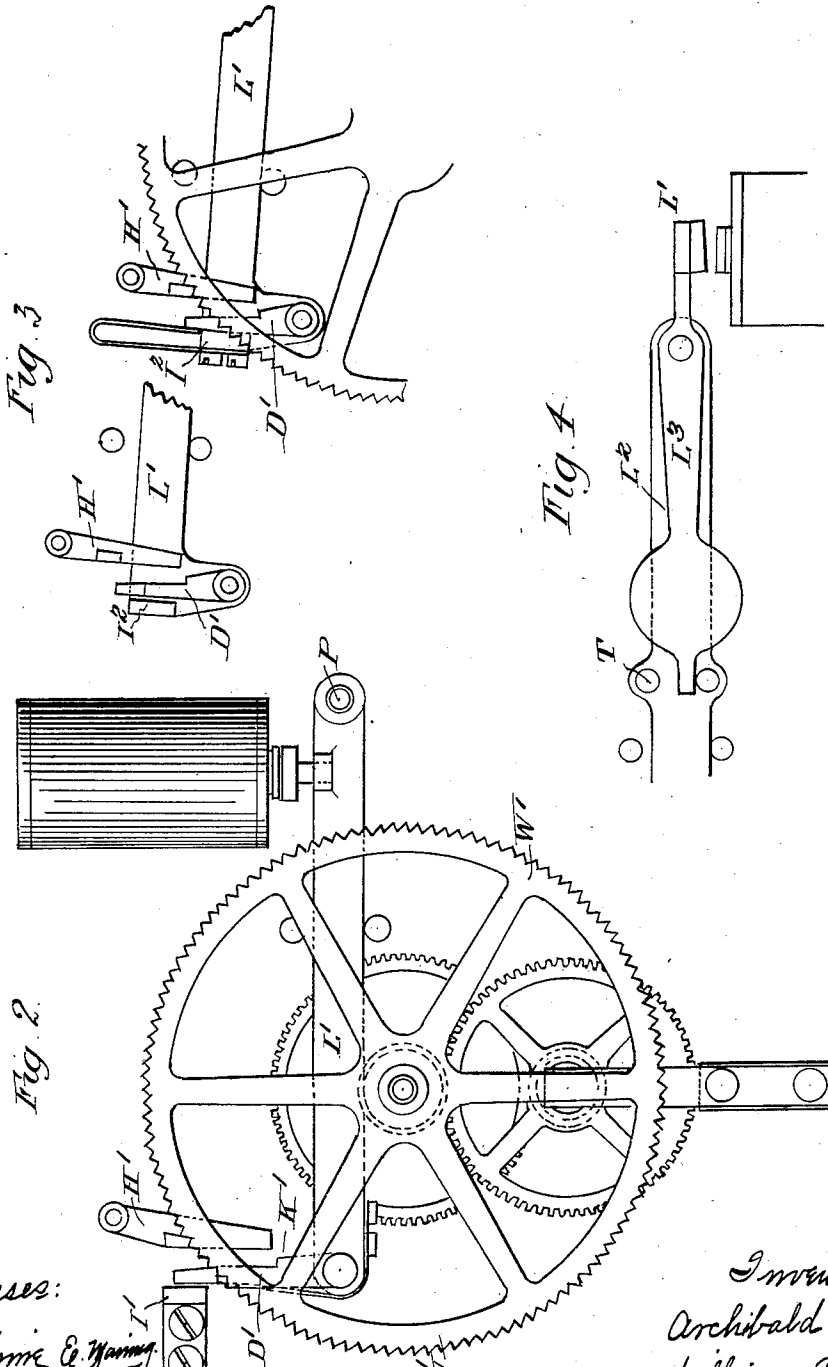

Fig. 3

Fig. 1

Fig. 2

Witnesses:

Katharine & Manning

Jacob Adams

Ludwig Becker

Inventors:

Archibald Barr  
William Stroud,  
By Freight Bros  
Attorneys.

No. 729,253.

PATENTED MAY 26, 1903.

A. BARR, W. STROUD & L. BECKER.

PAWL AND RATCHET MECHANISM FOR ELECTRIC CLOCKS.

APPLICATION FILED FEB. 5, 1901.

NO MODEL.

4 SHEETS—SHEET 4.

*Fig. 5, a*

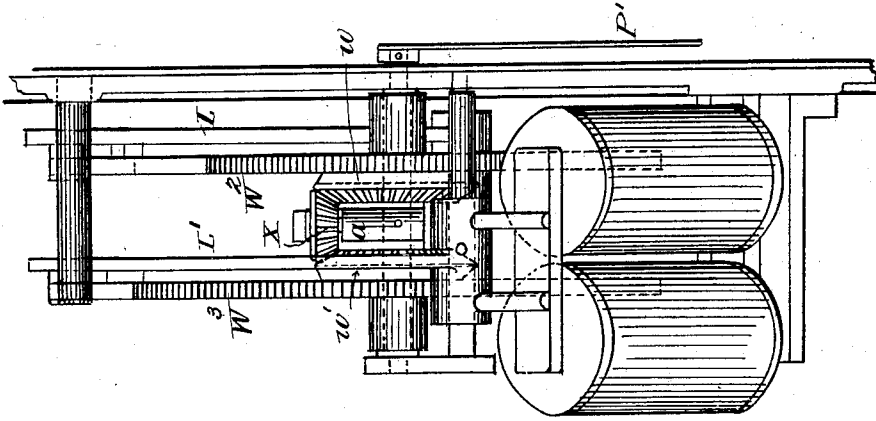

*Fig. 5*

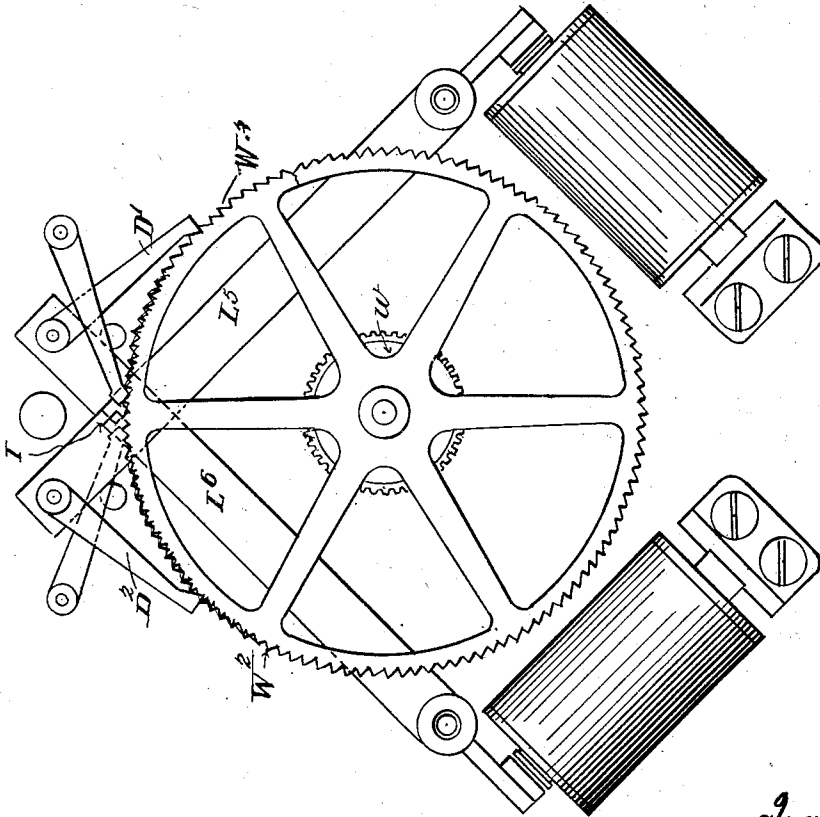

*Witnesses:*  
*Hathorn & Co. Manning*  
*J. Adams*

*Inventors:*  
*Archibald Barr*  
*William Stroud*  
*Ludwig Becker* *By* *Knights & Co.*  
*attorneys*

# UNITED STATES PATENT OFFICE.

ARCHIBALD BARR, OF GLASGOW, SCOTLAND, WILLIAM STROUD, OF LEEDS, ENGLAND, AND LUDWIG BECKER, OF GLASGOW, SCOTLAND.

## PAWL-AND-RATCHET MECHANISM FOR ELECTRIC CLOCKS.

SPECIFICATION forming part of Letters Patent No. 729,253, dated May 26, 1903.

Application filed February 5, 1901. Serial No. 46,101. (No model.)

*To all whom it may concern:*

Be it known that we, ARCHIBALD BARR, professor of engineering in the University of Glasgow, Glasgow, Scotland; WILLIAM STROUD, professor of physics in the Yorkshire College, Leeds, England, and LUDWIG BECKER, professor of astronomy in the University of Glasgow, Glasgow, Scotland, have invented certain new and useful Improvements in Electric Receivers and Electric Clocks, of which the following is a specification.

The object of our invention is the improvement of electric receivers and secondary electric clocks which are dependent for their action on receiving electric currents periodically from a transmitting instrument. The type of instrument to which the invention refers contains a ratchet-wheel which is prevented from turning backward by a retaining-pawl, an armature-lever actuated by an electromagnet, and a driving-pawl pivoted to the lever. When the armature is attracted and again released, the driving-pawl moves backward and forward over the periphery of the wheel through a distance slightly greater than the pitch of the teeth and moves the wheel forward tooth by tooth. So far the ratchet-wheel is free to move forward under externally or internally applied forces, for instance, by its own inertia or want of balancing of the moving parts.

Our invention consists in applying to the wheel a mechanical device which will perfectly control its step-by-step movement when the wheel is actuated by the lever, but which will prevent it not only in the two extreme positions of the lever, but in all the intermediate positions, from moving a step, owing to other forces applied externally or internally to the wheel.

Figure 1 is a front elevation of our device. Figs. 1<sup>a</sup>, 1<sup>b</sup>, and 1<sup>c</sup> are detail views. Fig. 1<sup>d</sup> is a side elevation of the device shown in Fig. 1. Fig. 2 is a side elevation of a modified form. Fig. 3 is a side elevation of still another modification. Fig. 4 is a side elevation of a modified form of an armature-arm. Fig. 5 is a side and Fig. 5<sup>a</sup> is an end elevation of a modification, showing a backward-and-forward movement of an indicator.

The following is a description of the action of the locking device:

L, Figs. 1, 1<sup>a</sup>, 1<sup>b</sup>, 1<sup>c</sup>, is the lever turning on the axis P, and it drives the wheel W by means of the driving-pawl D.

B and F are stops which limit the motion of L.

H is the retaining-pawl.

The lever L carries a stop I, whose action on the wheel and the retaining-pawl constitutes the invention.

In what follows we shall call the "forward motion" of the lever that which has the same direction as that of the wheel and the "forward position" of the lever that which ends the forward motion.

In the forward position of the lever, Fig. 1<sup>a</sup>, the stop I lies against the back of a tooth of the wheel and prevents it from moving forward. To make it impossible that a forward pressure applied to the wheel presses the lever aside and then moves the wheel forward, we make the line drawn perpendicular to the lower surface of the stop I and to the back of the tooth at the place where the two surfaces touch pass through (or in practice near to) the axis of rotation of the armature-lever. When the lever moves backward, the stop I at first acts in the forward position. Before the edge of the stop I moves clear of the tooth and also in all the succeeding positions of the lever until the backward position is reached the wheel is locked by the same stop I, in conjunction with the retaining-pawl H; Fig. 1<sup>b</sup>. The retaining-pawl H, which prevents the backward motion of the wheel, is placed below the stop I, and the latter moves at such a distance above the end of the retaining-pawl that it does not allow the pawl to rise sufficiently to clear the teeth of the ratchet-wheel. Forces acting on the wheel and tending to turn it onward will move the wheel less than the pitch of the teeth unless the stop I, and with it the lever, be pressed forward. The lever, however, cannot be pressed aside by such forces if the line joining the axis of rotation of the lever and the place of contact between the stop I and the retaining-pawl H be at right angles, or nearly so, to the two touching surfaces—viz., the

lower surface of the stop and the upper one of the retaining-pawl. In practice these surfaces can be planes at right angles to the line joining their centers and the axis of rotation, Figs. 1<sup>a</sup>, 1<sup>b</sup>, and 1<sup>c</sup>. The stop I thus effectively locks the wheel in all the positions of the lever from its forward position to its back position. When the lever moves forward from its backward position, (at which the driving-pawl D falls into the next tooth,) the driving-pawl D moves the wheel onward, and the retaining-pawl is raised by the wedge-like action of the moving tooth. The stop I does not interfere with the rising up to a certain point of the retaining-pawl, owing to the play between the two at the backward position of the lever, but the wheel is still locked by the stop I against forces acting on the wheel, since the retaining-pawl cannot rise sufficiently to clear the teeth. The breadth of the stop I is chosen so that the stop I just clears the retaining-pawl when the forward edge of the stop has already entered the space between the next teeth, Fig. 1<sup>a</sup>, and thus brings into action our first locking device. Finally the retaining-pawl falls into the next tooth, the lever arrives at its forward position, and the stop I suddenly arrests the motion of the wheel.

There is no position of the lever in which one or other of the locking devices does not act, and the wheel advances only one tooth, owing to one complete oscillation of the lever, although other forces, want of balance, or inertia are assumed to act on the wheel.

The application of this locking device to secondary electric clocks is shown in Fig. 1. L is the armature-lever, turning on the axis P. It drives the ratchet-wheel W by means of the driving-pawl D. B and F are the back and forward stops which limit the motion of armature L and define that of D. H is the retaining-pawl, and I the stop which controls the motion of the wheel. The wheel W bears one hundred and twenty teeth, and the minute-hand is fixed on its arbor. The other wheels constitute the ordinary hour-train.

The circuit of the electromagnet is closed and interrupted every half-minute by a contact-making contrivance of the regulating-clock.

Other forms of our invention are shown in Figs. 2 and 3.

In Fig. 2 the driving-pawl D' and the stop I', which is firmly fixed to the frame of the clock, take the place of the stop I of Fig. 1. L', P, W', D', and H' represent similar parts to those which they represent in Fig. 1; but in this case pawl D' is made a pulling instead of a pushing pawl, as in Fig. 1. In the forward position of the lever and also during the backward motion the driving-pawl D lies against the fixed stop I and prevents the wheel from being turned. When the lever L moves into the back position, the forward motion of the wheel W is checked by the end of

H coming in contact with the projection K on D, raising D until it is prevented from rising further by I. D, K, H, and I are so shaped and placed relatively to the wheel W as to effectually prevent any motion of W except that desired and caused by the motion of L.

A similar arrangement is shown in Fig. 3; but in this case the stop I is carried by the armature-lever itself. The action of the different parts is similar to that described in connection with Fig. 2.

In turret-clocks and others where the hands are exposed to wind-pressure external forces are often thereby applied to the clock mechanism, introducing pressure on the stop. This pressure tends to prevent the free motion of the armature-lever. In such cases we may arrange the armature-lever in two parts, L<sup>2</sup> and L<sup>3</sup>, Fig. 4, movable through a small angle relatively to each other, and we arrange the part L' (which is acted on by the magnetic force) so that it is always free to move under the action of that force, and it is not influenced by the friction at the inertia and other stops. This part, having been set in motion by the magnetic or other driving force and having considerable inertia, comes in contact with the pin T or other part of the composite armature-lever with a hammer-like action, setting it in motion and then carrying it along with it.

The clock may be arranged to take one step per minute or per half-minute or other desired interval.

It will be evident that our apparatus may be used to indicate at a distance, by means of intermittent electric currents or impulses of a mechanical, pneumatic, or other nature, signals other than those of time—as, for example, the transmitting of commands and of information concerning ranges on board a warship or in a fortress, or for indicating the height of the tide or of the water in a reservoir, or for indicating at the steering-wheel of a vessel the position of the helm, or for the conveying of any other information which may be indicated by a step-by-step motion imparted to a hand upon a dial or an index upon a scale or other indicating device.

When it is necessary or convenient that the hand or other indicator should move either backward or forward, two ratchet mechanisms of the kind above described may be provided and connected to the pointer or other indicator through a mechanism of the kind known as a "differential gear." Fig. 5 represents such an arrangement. L<sup>5</sup> and L<sup>6</sup> are the two armature-levers, driving, respectively, the two ratchet-wheels W and W' by means of the two pawls D and D'. One bevel-wheel *w* of the differential gear is pivoted on an arm *a*, fixed to the spindle which carries the pointer P. L and L' rotate W and W' in opposite directions, and the pointer P rotates in one or other direction, according as the one

or other circuit of the electromagnets is closed and opened by hand or by a suitable apparatus.

5 Having thus described our invention, the following is what we claim as new therein, and desire to secure by Letters Patent:

10 In clockwork mechanism applicable to secondary electric clocks and other receiving instruments, the combination with a ratchet-wheel driven by a lever and pawl, and a retaining-pawl locking said wheel against rotation in one direction, of a stop I fixed to the lever and engaging, in the forward position of the lever, a certain tooth of the wheel and  
15 restricting, in the backward positions of the lever, the motion of the retaining-pawl, the stop and retaining-pawl being so shaped that

the ratchet-wheel is prevented from rotating, or from being rotated when the lever is in intermediate positions as well as when it is  
20 in the forward or back position, or in any other manner than by the step-by-step motion desired and actuated, no matter how slowly, by the driving mechanism itself, substantially as described. 25

In testimony whereof we affix our signatures in the presence of two witnesses.

ARCHIBALD BARR.  
WILLIAM STROUD.  
LUDWIG BECKER.

Witnesses:

JOHN LIDDLE,  
EDITH MARY EDMONDSTONE.