

No. 842,590.

PATENTED JAN. 29, 1907.

C. E. TAYNTOR.

ROOF FOR MAUSOLEUMS, TOMBS, VAULTS, &c.

APPLICATION FILED JULY 14, 1906.

Fig. 1.

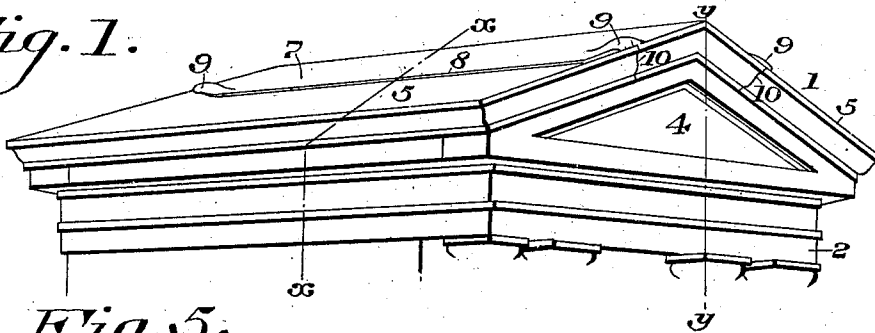

Fig. 5.

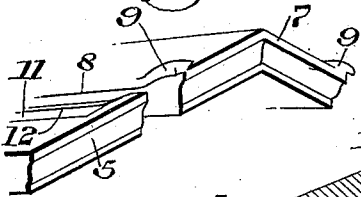

Fig. 2.

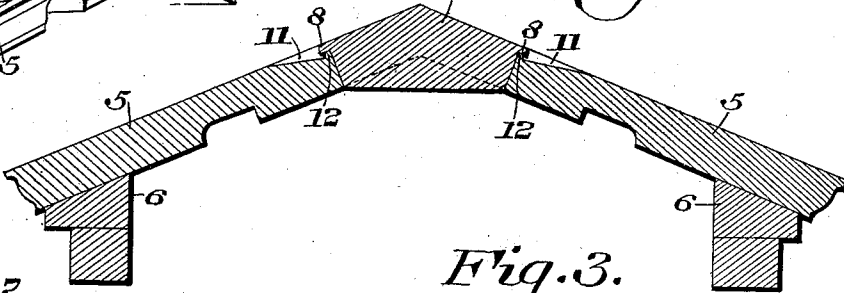

Fig. 3.

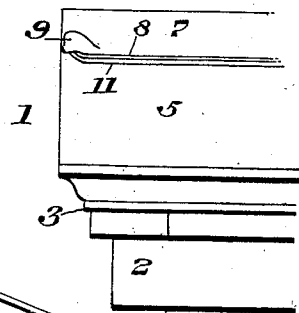
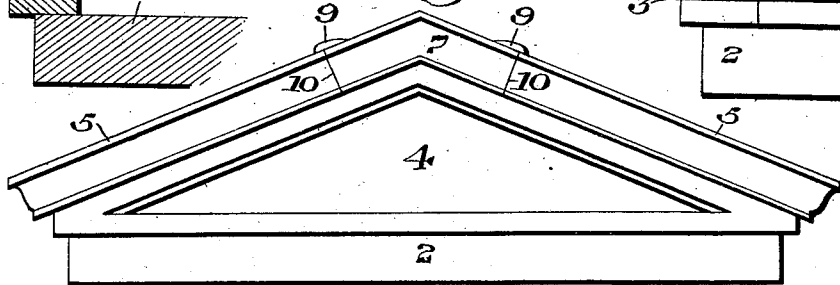
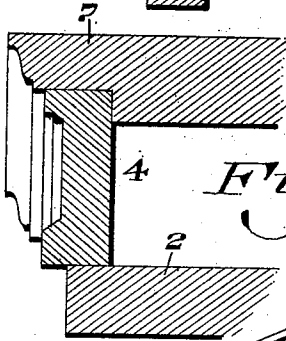

Fig. 4. Fig. 6.



Witnesses
P. F. Nagle.
L. Douville.

Inventor
Charles E. Tayntor.
Rudersheim & Fairbanks,
 Attorneys

UNITED STATES PATENT OFFICE.

CHARLES E. TAYNTOR, OF BROOKLYN, NEW YORK, ASSIGNOR TO C. E. TAYNTOR GRANITE COMPANY, OF HALLOWELL, MAINE, A CORPORATION OF MAINE.

ROOF FOR MAUSOLEUMS, TOMBS, VAULTS, &c.

No. 842,590.

Specification of Letters Patent.

Patented Jan. 29, 1907.

Application filed July 14, 1906. Serial No. 326,284.

To all whom it may concern:

Be it known that I, CHARLES E. TAYNTOR, a citizen of the United States, and residing at Borough Park, in the borough of Brooklyn, State of New York, have invented a new and useful Roof for Mausoleums, Tombs, Vaults, and the Like, of which the following is a specification.

In the construction of roofs for mausoleums, tombs, vaults, &c., or other buildings, and more particularly such as are constructed of granite or other stone and have a stone roof, it was for a number of years very difficult to construct a satisfactory roof of this character, which through change of temperature and long-continued exposure to the weather would not be liable to such a separation of the various stones as to effect the stability and life of the roof, thereby producing seams and causing the roof to become discolored and permitting percolation of water therethrough, this action being due largely to frost and the absence of such a permanent joinder of the parts as would resist the same. To obviate these disadvantages, I designed, prior to the year 1899, a novel construction of a roof for buildings of this character with the object in view to provide an improved, simple, and strong roof construction, in which the seams by the junction of the several parts of the roof were well protected without interfering with the vision-lines of the roof, for which invention I was granted Letters Patent No. 635,984, dated October 31, 1899. Subsequently I made further improvements in structures of this character and devised a roof comprising pediments having side roof-stones provided with ribs along their inner top edges and a central roof-stone having lips along its opposite side edges fitted to overlap the ribs upon the side roof-stones, whereby a novel roof construction was produced, in which the seams formed by the junction of the several parts of the roof were well protected, so as to prevent rain from driving through said seams and the consequent percolation of water therethrough.

In my present invention I have devised another novel construction whereby I am enabled to assemble the parts comprising the roof in a very cheap and expeditious manner, and by my novel manner of uniting the cen-

tral roof or cap stone with the two side roof-stones and by the provision of gutters contiguous to the inner top edges of the side roof-stones which are adapted to be overlapped by lips along the opposite side edges of the central roof-stones when these parts are assembled I effect a junction of the parts which is rain, water, or frost tight under all conditions, and thus form drip-gutters of such a character that all moisture is prevented from entering the seams of joints common to the central roof or cap stone and the top side roof-stones.

To the above end my invention consists, broadly, in the novel construction of a roof for mausoleums, tombs, vaults, and the like whereby the various stones are so united to prevent improper movement of any one stone, and gutters are provided in each side roof-stone and overlapped by lips on the central roof-stone, so that the seams formed by the juxtaposed stones cannot be acted upon by the elements, nor do they detract from the appearance of the structure, said seams being thereby well protected, so as to prevent rain or moisture from driving through them, said gutter and side roof-stones being so formed that when the central roof or cap stone is in position a straight vision-line is formed from the outer edge of the side roof-stones to the top edge of the central or cap stone.

It further consists in providing a disappearing swell at the outer side edges of the central roof or cap stones.

It further consists of other novel features of construction, all as will be hereinafter fully set forth.

Figure 1 represents a perspective view of the front upper portion of a roof for mausoleums, vaults, tombs, and the like embodying my invention. Fig. 2 represents a sectional view on line *x x*, Fig. 1. Fig. 3 represents a side view of the roof as seen in Fig. 1. Fig. 4 represents a sectional view on line *y y*, Fig. 1. Fig. 5 represents a perspective view of the central roof-stone and one of the side roof-stones in detached position. Fig. 6 represents a front elevation of the roof seen in Fig. 1.

Similar numerals of reference indicate corresponding parts in the figures.

Referring to the drawings, I have illus-

55

60

65

70

75

80

85

90

95

100

105

trated my invention as applied to the roof of a mausoleum and have omitted to show or describe in detail any portion of the structure below the frieze or top course of the wall.
 5 To avoid needless repetition, I have shown and will describe and claim only one pediment of a building, it being understood that both ends of the building are constructed and assembled in substantially the same way, as will be apparent to those skilled in the art.

1 designates the roof of a mausoleum, vault, tomb, or the like having a front frieze or top course 2, which, together with the side courses, support the roof proper. Resting upon the top course is the cornice 3 and pediment 4 or its equivalent, which may be made of a single stone or of two or more stones, as desired, said pediment being preferably triangular and pitching in opposite directions laterally to regulate the pitch of the roof.

5 designates the side roof-stones, which rest upon and lap the pediment 4 sufficiently to insure permanency, these parts being provided with mortises and tenons, respectively, in the usual manner to prevent said stones sliding, said stones 5 forming the opposite sides and overhanging eaves of the roof.

6 designates side or filler stones fixed on top of the frieze or side top course, which match and connect the returns of the pediments at the opposite end of the building and also serve as a part of the supporting structure of the roof, it being, however, sometimes the practice to make these side stones integral with said roof-stones, and when so made they form part of said roof-stones.

7 designates the central roof, ridge, or cap stone, which is provided with a longitudinally-extending lip 8, which has an overhanging extension and the upper face of said lip being in the same plane as the upper face of the central roof-stone 7, so that a straight vision-line is presented by said central roof-stone.

9 designates a swell or hump which is situated at each extremity of said lip 8, said swells or humps being adapted to overhang the joints 10, formed between the central outer edges, as best understood from Fig. 1, it being seen that said swells are curved away in all directions, and thus disappear.

12 designates an upwardly-extending seat adjacent the outer top portion of each of the side roof-stones 5, which seats serve as a wall for the gutters 11, which are formed in the upper portion of each of the said side roof-stones 5 and extend longitudinally thereof any desired distance. When the stones are in position, the under side of the lips 8 overhang the seats 12 and project beyond the same, so that said lips 8 overhang the gutters, it being noted that the seats 12 are of such height and the gutters are so formed in

the side roof-stones that the lips 8 are within the plane of the upper surface of the side roof-stones 5 and central roof-stone 7, so that a straight vision-line is presented, formed between the upper faces of the roof-stone, and that the lips 8 will direct all moisture into said gutters and that by reason of the location of the lips 8, overhanging and extending beyond the seats 12, rain and moisture are effectually prevented from being driven through the seams into the interior of the roof structure. The disappearing swells 9, situated at the extremities of the lips 8, overhang the seams 10 and effectually prevent moisture and rain from being driven there-through. At the same time they do not interfere with the vision-line, because of their curving away in all directions, and thus disappearing.

It will be apparent from the figures that the gutters 11 terminate at each end of the structure a short distance before the end of the roof structure is reached and that the swells 9 disappear by being merged into the central roof-stones 7, but at the same time serve to direct the moisture from the roof-stones and the outer edges into the gutters.

The advantages of my novel construction will be apparent to those skilled in the art, since it is manifest that by the novel manner of uniting the side or filler roof-stones and the central roof or ridge stones that a roof is produced which possesses permanency, strength, and power, but resists the elements, and by reason of the lips 8 being in a straight vision-line, as that of the upper surface of the side roof-stones and central roof-stones, the pleasing and ornamental appearance of the structure is enhanced, and as the swells 9 extend in all directions the vision-lines of the roof at the edges will not be interfered with, and at the same time the gutters 11 are so constructed with respect to the lips 8 that when the parts are assembled water and frost are prevented from penetrating or affecting the seams, thus preventing percolation of the water therethrough. It will be further apparent that by reason of the countersinking of the parts 11 a roof constructed in accordance with my novel invention will have its vision-line not interfered with in any direction and will, furthermore, be extremely strong and durable.

While I have shown three roof-stones in the accompanying drawings, it is evident that a greater or lesser number of roof-stones may be employed and that other slight changes may be resorted to in the form, construction, and arrangement of the several parts without departing from the spirit and scope of my invention, and I do not, therefore, desire to be limited in every instance to the exact construction herein shown and described.

Having thus described my invention, what I claim as new, and desire to secure by Letters Patent, is—

1. A roof for mausoleums, vaults and the like comprising pediments, side roof-stones, an upwardly-extending seat adjacent the outer top portion of said side roof-stones, a depressed gutter in each of said side roof-stones in their upper surfaces, a central roof-stone and lips along its opposite side edges resting upon said seats and overhanging said gutters and situated within the plane of the upper surface of said roof-stones and presenting a straight vision-line.

2. A roof for mausoleums, vaults and the like, comprising pediments, side roof-stones, each having a depressed gutter extending longitudinally thereof near its outer top portion, a central roof-stone having lips along its opposite side edges, said lips adapted to overhang said gutters and situated within the plane of the upper surface of said roof-stones and presenting a straight vision-line.

3. A roof for mausoleums, vaults and the like, comprising pediments, side roof-stones, an upwardly-extending seat adjacent the outer top portion of said side roof-stones, a gutter extending longitudinally of said roof-stones, a central roof-stone, lips projecting along its opposite side edges overhanging said gutters and situated within the plane of the upper surface of said roof-stones and disappearing swells adjacent the outer ends of said lips.

4. A roof for mausoleums, vaults and the like, comprising pediments, side roof-stones, each having a depressed gutter extending longitudinally thereof near its outer top portion, a central roof-stone having lips along its opposite side edges, said lips overhanging said gutters and being within the plane of the upper surface of the roof-stones and disappearing swells adjacent the ends of said lips.

5. A roof for mausoleums, vaults and the

like comprising pediments, side roof-stones, an upwardly-extending seat adjacent the outer top portion of said side roof-stones, a central roof-stone and lips along its opposite side edges resting upon and overhanging said seats and situated within the plane of the upper surface of said roof-stones and presenting a straight vision-line, and disappearing swells above the planes of said lips.

6. A roof for mausoleums, vaults and the like, comprising pediments, side roof-stones, each having a gutter extending longitudinally thereof near its outer top portion, a central roof-stone having lips along its opposite side edges, said lips adapted to overhang said gutters and situated within the plane of the upper surface of said roof-stones and presenting a straight vision-line, said gutters being extended beyond the lips.

7. A roof for mausoleums, vaults and the like, comprising pediments, side roof-stones, an upwardly-extending seat adjacent the outer top portion of said side roof-stones, a gutter extending longitudinally of said roof-stones, a central roof-stone, lips projecting along its opposite side edges overhanging said gutters and situated within the plane of the upper surface of said roof-stones and disappearing swells curved away in all directions adjacent the outer ends of said lips.

8. A roof for mausoleums, vaults and the like, comprising pediments, side roof-stones, each having a gutter extending longitudinally thereof near its outer top portion, a central roof-stone having lips along its opposite side edges, said lips overhanging said gutters and being within the plane of the upper surface of the roof-stones and disappearing swells curved away in all directions adjacent the ends of said lips.

CHARLES E. TAYNTOR.

Witnesses:

E. HAYWARD FAIRBANKS,
C. D. McVAY.