

(19) World Intellectual Property Organization
International Bureau



(43) International Publication Date
20 August 2009 (20.08.2009)

PCT

(10) International Publication Number
WO 2009/101586 A2

(51) International Patent Classification:

F24J 2/00 (2006.01) F24J 2/04 (2006.01)
F24J 2/14 (2006.01) F24J 2/08 (2006.01)
F24J 2/07 (2006.01) F24J 2/34 (2006.01)

(21) International Application Number:

PCT/IB2009/050561

(22) International Filing Date:

11 February 2009 (11.02.2009)

(25) Filing Language:

English

(26) Publication Language:

English

(30) Priority Data:

2007/08389 11 February 2008 (11.02.2008) ZA

(71) Applicants and

(72) Inventors: **DU TOIT, Jacobus Christiaan Faure** [ZA/ZA]; 347 Umgeni Street, Erasmuskloof Extension 4, 0183 Pretoria (ZA). **SCHUTTE, Adriaan Nicholaas** [ZA/ZA]; 12 Suikerbos Drive Lydiana, 0184 Pretoria (ZA).

(74) Agent: **DESSINGTON DE BEER**; P O Box 1238 Rivonia, 2128 Johannesburg (ZA).

(81) Designated States (unless otherwise indicated, for every kind of national protection available): AE, AG, AL, AM, AO, AT, AU, AZ, BA, BB, BG, BH, BR, BW, BY, BZ, CA, CH, CN, CO, CR, CU, CZ, DE, DK, DM, DO, DZ, EC, EE, EG, ES, FI, GB, GD, GE, GH, GM, GT, HN, HR, HU, ID, IL, IN, IS, JP, KE, KG, KM, KN, KP, KR, KZ, LA, LC, LK, LR, LS, LT, LU, LY, MA, MD, ME, MG, MK, MN, MW, MX, MY, MZ, NA, NG, NI, NO, NZ, OM, PG, PH, PL, PT, RO, RS, RU, SC, SD, SE, SG, SK, SL, SM, ST, SV, SY, TJ, TM, TN, TR, TT, TZ, UA, UG, US, UZ, VC, VN, ZA, ZM, ZW.

(84) Designated States (unless otherwise indicated, for every kind of regional protection available): ARIPO (BW, GH, GM, KE, LS, MW, MZ, NA, SD, SL, SZ, TZ, UG, ZM, ZW), Eurasian (AM, AZ, BY, KG, KZ, MD, RU, TJ, TM), European (AT, BE, BG, CH, CY, CZ, DE, DK, EE, ES, FI, FR, GB, GR, HR, HU, IE, IS, IT, LT, LU, LV, MC, MK, MT, NL, NO, PL, PT, RO, SE, SI, SK, TR), OAPI (BF, BJ, CF, CG, CI, CM, GA, GN, GQ, GW, ML, MR, NE, SN, TD, TG).

Published:

— without international search report and to be republished upon receipt of that report (Rule 48.2(g))

(54) Title: SOLAR ENERGY COLLECTOR AND SYSTEM

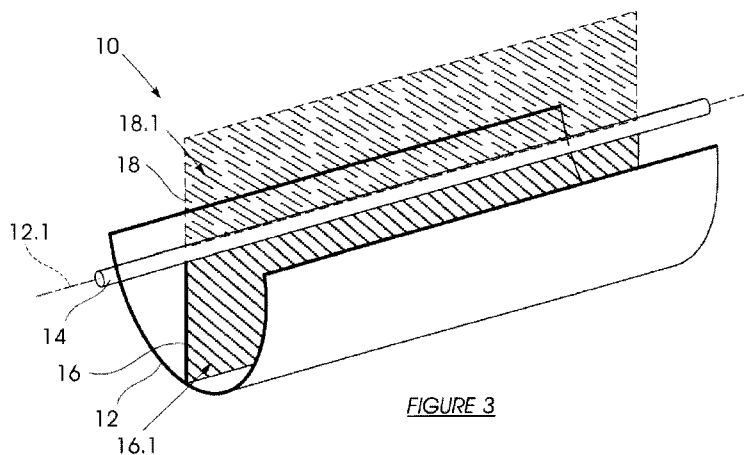

FIGURE 3

(57) Abstract: There is disclosed a solar energy comprising an optical solar radiation concentrator that is operable to direct incident solar radiation to a primary solar energy collector and a secondary solar energy collector that is configured to collect at least some solar energy from diffuse solar radiation not directed to the primary solar energy collector. Also disclosed is a holistic solar energy system and energy supply system.

WO 2009/101586 A2

5

SOLAR ENERGY COLLECTOR AND SYSTEM**FIELD OF THE INVENTION**

10 This invention relates to a solar energy collector and system for its use, which allows for the utilisation of solar energy as a holistic distributed energy source.

BACKGROUND TO THE INVENTION

15 With the increase in costs of current energy sources as well as the negative environmental effects of these sources, a renewed interest is shown in renewable energy sources. Renewable energy systems cover a large variety of sources and the aim is to harness the energy opportunities locked into these. Major sources are wind, wave, hydro, geothermal and solar. This invention focuses on solar energy, since it is the most abundant form of renewable energy on the planet, its harnessing may have the least negative environmental impact of the renewable energy sources, and it provides the most scope for improvement over current systems.

20 Energy produced from renewable sources is typically substantially more costly when compared to traditional sources such as fossil fuels and nuclear reactions. This is mostly due to the fact that the energy density of renewable sources (that is the amount of power that can be generated per volume of space of the collection / conversion equipment) is very low when compared to traditional sources. Thus, for an equivalent output a renewable power plant is many times the physical size of a fuel fired power plant and therefore typically considerably more expensive.

30

Another consequence of the low energy density of renewable resources is the relatively low efficiency of the means to convert the input power to useful forms such as electricity. This is true for photovoltaic panels, but is especially relevant to the conversion of solar energy by means of a heat engine. Since the incident solar energy density is low, it is difficult to attain the high working fluid temperatures that are encountered in traditional plants, even through concentration. This results in a substantial fraction of the input energy having to be rejected as heat to the surrounding environment.

35

Renewable energy is presently most often collected in a large installation from where it is 'transported' to the point of use. Examples of these are heliostat, parabolic trough and wind farm installations, where the renewable energy is converted to electrical energy in a centralized facility and 'transported' to users via an electrical distribution network. This centralized generation scheme prevents the further utilization of potentially useful forms of energy that are by-products of the electrical generation process, e.g. rejected heat from a solar fired heat engine. Due to the low temperatures involved, the heat rejected is typically several times greater than the useful energy produced.

10 Thus, in summary, renewable energy is expensive to collect and only a small fraction of it can be converted to a form that is easily transportable over long distances, resulting in the bulk of the collected energy having to be discarded to the surrounding environment. These are the major factors contributing to the high cost of renewable energy.

15 Most efforts intended to reduce the cost of renewable energy are focused on either reducing the cost of the plant and equipment, or on increasing the efficiency of the components and overall system. The latter is typically accomplished through improved optics and absorption surfaces, higher concentration ratios, more efficient thermodynamic cycles and so forth. These incremental improvements are however
20 inadequate to provide the breakthrough needed to bring down the cost of renewable energy to the levels of traditional sources.

Apart from the above mentioned problems, solar energy suffers from at least two further negative aspects. The first is that the energy is only available between sunrise and sunset, and the solar output is influenced by seasonal variations, weather and so forth.
25 The second is that in most concentrator systems, when the sunlight is diffused by clouds, the energy level falls to almost zero. In systems that try to combine concentration with the ability to handle diffused energy, the concentration level is low and the overall system efficiency tends to be low.

30

OBJECT OF THE INVENTION

It is the objective of this invention to provide a solar energy collector and system that at least partly overcome the above mentioned problems.

35

SUMMARY OF THE INVENTION

In accordance with a first aspect of this invention there is provided a solar energy collector comprising an optical solar radiation concentrator operable to direct incident solar radiation to a primary solar energy collector and a secondary solar energy collector configured to collect at least some solar energy from diffuse solar radiation not directed to the primary solar energy collector.

There is further provided for the optical solar radiation concentrator to comprise a trough reflector, preferably a parabolic trough reflector, alternatively a circular or similar shaped trough reflector, having a focal line for reflected solar radiation, for the primary energy collector to be configured to collect solar energy from direct solar radiation concentrated along the focal line, and for the secondary energy collector to be configured to collect solar energy from diffuse solar radiation in a plane extending at least partly between the reflector and the focal line.

There is further provided for the primary collector to comprise a line receiver or a series of point receivers arranged in a line, and for the secondary collector to comprise a plate receiver or a series of line receivers arranged in a plane to form a plate receiver.

There is also provided for at least one of the line receivers in the plate receiver to comprise a series of point receivers arranged in a line.

There is still further provided for the line or point receivers forming the primary collector each to comprise a fluid conduit which presents fluid to the focal line and to be configured to heat the fluid, preferably to a first or a second temperature, alternatively a first and second temperature; and for the plate, line or point receivers forming the secondary collector each to comprise a fluid conduit which presents fluid to the plane of the secondary collector and to be configured to heat the fluid, preferably to a third temperature; wherein the first temperature is greater than the second temperature, and the second temperature is greater than the third temperature.

There is also provided for one or both of the primary and secondary energy collectors to include photovoltaic cells configured to generate electrical energy and transfer collected solar energy to the fluid conduit associated with it.

There is still further provided for the secondary energy collector to extend in a plane between the focal line and the bottom of the trough, and preferably to extend in a plane above the focal line.

- 5 There is also provided for the fluid in the fluid circuits to comprise a gas, liquid or a vapour.

There is also provided for the optical solar radiation concentrator to comprise a Fresnel lens.

10

- According to a further feature on the invention there is provided a solar energy system which includes at least a solar energy collector, preferably as defined above, any one or more of a high temperature fluid circuit for fluid at about the first temperature, a medium temperature fluid circuit for fluid at about the second temperature, and a low temperature fluid circuit for fluid at about the third temperature, wherein the high and medium temperature circuits are connected to high or medium temperature heat sinks to operatively utilize heat from the high or medium temperature fluid circuits, alternatively or in addition to a heat engine to operatively generate electricity, and the low temperature circuit is connected at least to a low temperature heat sink to operatively utilize heat from the low temperature fluid circuit.
- 15
20

There is further provided for fluid to be collected from the output side of the heat engine at a temperature lower than the first temperature and to be introduced into the medium or low temperature circuits.

25

- There is also provided for the high temperature circuit to include a high temperature energy storage device, including a fluid or alternative energy storage medium, including salt, device, alternatively or in addition to a high temperature backup energy generator, and for the backup energy generator to convert a fuel to heat or alternative energy storage media which is used to heat the fluid in the high temperature circuit, and preferably for the backup energy generator to utilize a gas fuel and to comprises a heat engine.
- 30

- There is further provided for the high temperature heat sinks to include one or more of cooking, baking and drying apparatus, for the medium temperature heat sinks to include one or more of refrigeration, space cooling and dehumidifying apparatus, and for the low temperature heat sink to include one or more of space heating and water heating apparatus, including but not limited to swimming pool water heating.
- 35

There is still further provided for the medium temperature circuit to include a medium temperature energy storage device, including a fluid or alternative energy storage medium, including salt, device, and for the low temperature circuit to include a low temperature energy storage device, including a fluid or alternative energy storage medium, including salt, device, alternatively or in addition to a medium temperature backup energy generator, and for the medium temperature backup energy generator to convert a fuel to heat or alternative energy storage media which is used to heat the fluid in the medium temperature circuit, and preferably for the medium temperature backup energy generator to utilize a gas fuel and to comprises an internal combustion engine.

There is also provided for the system to include electrical energy storage devices, including batteries and capacitance storage devices.

There is also provided for the system to include solar radiation tracking means and control and drive means configured to track the sun and manipulate the orientation of the optical solar radiation concentrator in respect of the sun to optimise the collection of solar energy.

There is also provided for the high, medium and low temperature circuits to include control means for the respective heat sinks, including valves, thermostats and pumps, the valves including control and shut-off valves and the pumps including positive displacement pumps; and for the system to include an optional heat dissipater.

There is still further provided for the system to include control means to balance the pressure in the high, medium and low temperature circuits, and for the control means to include pressure and flow regulators utilizing pressure, flow and temperature data, and more preferably for the pressure in the system to be controlled by measuring temperature in the system and using feedback control to the various circuits thereby balancing energy flow in the system, and including pressure accumulators to control sudden pressure changes in the system.

According to a further feature of the invention there is provided for the system to include communication means configured to allow the system to communicate with a remote controller, for the system to be configured to at least receive data in respect of energy availability and current and expected energy consumption data for a predetermined geographical area within which the system is located from the remote controller, to process the data and manage the energy utilization of the system accordingly, and

preferably for the system to also transmit data in respect of energy availability and current and expected energy consumption of the system to the remote controller for incorporation in the data available from the remote controller.

- 5 There is further provided for the communication means to comprise a communication channel utilizing any one or more of the Internet, cellular phone technology (GSM, 3G, HSDPA, etc), land line telephony systems, radio communication systems or communication through electrical power networks.
- 10 According to a still further feature of the invention there is provided an energy supply system comprising an electricity supply network in respect of a predefined geographical area, which includes a plurality of electricity consumers of which at least one consumer, and preferably a plurality of consumers, has a solar energy system as defined above installed and operational at its premises, wherein the energy supply system receives
- 15 data from the solar energy system in respect of at least its current usage requirements and the energy supply system utilizes this data to make a determination of the total current energy requirement of the electricity supply network in respect of the geographical area.
- 20 There is also provided for the solar energy system to include in the data provided to the energy supply system data with respect to expected usage requirements and current and expected energy surpluses, and for the energy supply system to obtain surplus energy from the solar energy system.

25 BRIEF DESCRIPTION OF THE DRAWINGS

Embodiments of the invention are described by way of example only and with reference to the accompanying drawings in which:

- 30 Figure 1 shows an end view of a first embodiment of a solar collector according to the invention, having an elongate parabolic reflector;
- Figure 2 shows an end view of a second embodiment of a solar collector according to the invention, having an elongate circular cross sectional reflector;
- Figure 3 shows a perspective view of third embodiment of a solar collector
- 35 according to the invention;
- Figure 4 is a schematic diagram showing the holistic distributed solar energy system;
- Figure 5 detail of sections 000 to 200 of Figure 4;

- Figure 6 detail of sections 250 to 400 of Figure 4;
Figure 7 detail of sections 500 to 700 of Figure 4;
Figure 8 detail of sections 750 to 900 of Figure 4;
Figure 9 detail of generation and alternating current loads; and
5 Figure 10 detail of control and direct current loads.

DETAILED DESCRIPTION OF THE INVENTION

10 In Figure 1 a solar collector (10) is shown. The solar collector (10) comprises a solar concentrator in the form of an elongate parabolic reflector (12), a primary solar absorber (14) positioned on the focal line (12.1) of the reflector (12) co-axial to the primary solar absorber (14), and a secondary solar absorber (16) positioned in the plane of symmetry of the reflector (12) in line with the focal line (12.1).

15 As can be seen in Figure 1, solar radiation indicated as lines 20 to 33 falls onto the reflector (12), is reflected from it, and is focussed on the focal line (12.1). The focussing of the radiation onto the focal line (12.1) is a function of the shape of the parabolic reflector (12). However, in event of misalignment of the reflector (12) with the incoming radiation (20 to 33), the reflected radiation will advantageously fall onto the secondary
20 absorber (16). In event of atmospheric interference with the radiation (20 to 33) the radiation (20 to 33) may be dispersed causing it to be focussed at another point distal from the focal line (12.1). In this event the reflected solar radiation will also fall onto the secondary absorber (16).

25 In this example, the primary solar absorber (14) is in the form of a high density photo voltaic collector and the secondary solar absorber (16) is in the form of a fluid cooled heat collector. However, it is to be appreciated that any other type of solar absorber can be used in the place of the photo voltaic absorber (e.g. a heat absorbing fluid filled tube) and the fluid cooled heat absorber (e.g. a photo voltaic panel).

30

In Figure 2 a solar collector (48) which comprises an elongate, circular cross sectional solar reflector (46) and a combined primary and secondary solar absorber (70) positioned in the focal plane (46.1) of the concentrator, which is in the plane of symmetry of the solar collector (48).

35

As can be seen in Figure 2, solar radiation indicated as lines 50 to 68 falls onto the reflector (46), is reflected from the reflector (46), and is focussed onto the focal plane (46.1) which is co-planar with the combined primary and secondary solar absorber (70).

The focussing of the radiation onto the focal plane (46.1) is a function of the circular cross sectional reflector (46). It is to be appreciated that any type of reflector that approximates a parabolic reflector will reflect incident radiation onto a so called focal plane. However, it is further to be appreciated that the radiation will not necessarily be collimated to a point or line. The term "focus" is therefore used in the context of directing light onto a plane or line and not limited to collimating the light onto a particular plane, line or point.

In this example, the combined primary and secondary solar absorber (70) is in the form of a fluid cooled heat collector. However, it is to be appreciated that any other type of solar collector can be used in the place of the heat collector.

In Figure 3 a collector similar to the collector shown in Figure 1 is shown in perspective view. Same reference numerals have been used for the same components. However an additional secondary collector (18) is shown in a plane (18.1) which is located in the plane of symmetry above the focal line (12.1). The secondary solar collector (16) is shown in a plane (16.1) which is located in the plane of symmetry below the focal line (12.1).

20 Modular Description of the Holistic Energy System – Figures 4 to 10

The second part of the invention has been divided into modular sections which may be omitted or included in a practical system depending on several factors including, but not limited to, where the system is to be used, what loads will be supplied, the system budget, etc. Thus any combination of the system sections may be used, although some combinations will be more practical than others. In addition, some sections may be relocated to different positions in the system. This will be discussed after the system description. Not all combinations are discussed in this invention, but are still provided for.

Some components may be omitted from individual sections without significantly affecting the operation of the system. Furthermore, many components, arrangements and sections may be duplicated to provide additional performance and/or functionality, without affecting the basic operation of the system.

The method of control of the distributed solar energy system is briefly discussed as necessary in every module or section, with a summary at the end of the detailed description.

Section 000: Solar Input – Figure 5

Solar energy is received from the sun via one or more receivers. Receivers may be of plate type, in which case they are to be used without any concentrating means or with
5 low-concentration optics. Receivers may also be of line (tube) or point (cavity) types, in which case they are used with means to concentrate solar radiation onto the receiver (e.g. parabolic or cylindrical troughs and dishes, Fresnel lenses, heliostats, etc.). Plate receivers are capable of receiving both direct and diffuse radiation, while concentrating receivers are typically capable of only receiving direct solar radiation.

10

The present invention uses one or more solar radiation receivers capable of receiving direct and/or diffuse radiation. The type and number of receivers is a function of where the system will be located, and what loads will be supplied. The diagram in Fig 5 shows a typical system with two receivers, one a high-concentration ratio receiver (000) for
15 direct radiation and a low-concentration ratio receiver (050) for diffuse radiation (the low-concentration receiver would also include the case of no concentration). In practice any combination and number of receivers may be used.

The invention makes provision to utilise a solar receiver such as shown in Figures 1 to 3,
20 in addition to other types of receivers. If any of the receivers discussed in Figures 1 to 3 is used it would combine the high and low concentration receivers in one unit and any number of these could be utilised.

Heat transfer fluids are used to conduct absorbed solar energy from the receivers. The
25 receivers may first convert the radiation to some other useful form of energy (e.g. photovoltaic cells generating electricity) before the heat is conducted away by the transfer fluid, or the received radiation may be directly converted to heat and conducted away by the fluid. Different fluids may be used to conduct the heat from different receivers, and the fluid may either be in liquid or gas/vapour form.

30

Means of establishing flow of heat transfer fluid through the receivers are provided, and the flow through each receiver is controlled to provide flow of heat transfer fluid of approximately constant temperature after the receiver output. This will cause the flow through the receiver to be approximately proportional to the solar input power. In the
35 diagram the flow is established through two speed-controllable pumps (010, 060), although any means for establishing and controlling a flow through the receivers may be used (e.g. a single pump with proportional valves, gravity, etc.).

The high concentration ratio receivers are capable of producing heated fluid of high temperature, typically in the order of hundreds of degrees Celsius, while non- or low-concentration receivers will typically produce medium temperatures of less than 100 degrees Celsius.

5

Section 100: Backup Heat Input – Figure 5

When the energy received from the sun is lower than the demand for a period of time, it may be necessary to augment the solar input with heat from other sources. These
10 sources may be any type of fuel, or alternative sources including but not limited to nuclear and geothermal sources. One or more heat exchangers are used to transfer heat from the sources to the heat transfer fluid. Again means of establishing and controlling flows through the heat exchangers is provided in the form of pumps (110 and 160), so that the fluids exit the exchangers at approximately constant temperature. The flow
15 through the exchangers is again approximately proportional to the heat delivered by the sources.

The diagram shows a fuel-fired boiler (100) and associated heat exchangers which augment the output of the solar receivers. A single source is used to heat both the very
20 high and low temperature fluids, although any number of sources may be used to heat the fluids to desired temperatures.

Section 200: High Temperature Storage – Figure 5

If the received solar energy is greater than the demand, the use of backup sources may be minimized by storing excess thermal energy. This excess thermal energy is stored at high temperature and could be used in the system when supply is lower than demand. These storage devices (200) accept heated fluid and store this energy either by directly storing the heated fluid, or by transferring the heat of the fluid to other substance(s) and
30 storing it as sensible, latent or chemical energy within those substance(s) or system(s).

A means of establishing and controlling a reversible flow through the storage device is provided. When excess energy is available, high temperature heat transfer fluid is conducted through the storage device by running the pump (210) in reverse, thereby
35 storing energy in the device. When the solar energy input is less than the demand, the pump is run forward so that cold transfer fluid enters the device and high temperature fluid is made available to the remainder of the system. The flow does not necessarily need to be reversed to extract energy from the storage device; any arrangement may be

used where cold fluid is passed through the device so that it exits at a high temperature. Again, any means of establishing the flow through the storage device(s) may be used.

5 Since the flows through all heat sources and sinks in the circuit are controlled so that they are approximately proportional to the rate of heat being delivered or sourced, the high temperature conduit pressure can be used as an indication of the heat energy supply and demand relationship. In a situation where excess heat energy is produced, the pressure in the high temperature conduit will rise and the pump (210) must be operated in reverse in order to store energy in the storage device (200). When the input
10 energy is lower than the demand, the pressure in the high temperature conduit will fall, and the pump (210) must be operated in the forward mode in order to supply heated fluid to the sinks (see Section 250 below).

Thus, the pump (210) is controlled via pressure sensor (PT230) so that the function of
15 the pump (210) is to balance the flow of energy between the energy sources and sinks. An accumulator (230) is provided to prevent sudden pressure fluctuations in the high temperature fluid conduit, which makes the system more controllable.

Section 250: High Temperature Sinks – Figure 6

20 These heat sinks are user devices which accept heated fluid at high temperature. Examples include ovens, stoves and other cooking devices, dish washers, tumble driers ironing devices and so forth.

25 The flow through each sink is controlled by a thermostat (262, 272), pump or any other means to ensure that the sink receives the amount of heat required.

The diagram shows two high temperature sinks (261, 271), although the system may contain any number of high temperature sinks, including none.

30 Solenoid valves (260, 270) are provided to switch the sinks in and out of the circuit. This would then also allow for low-priority heat sinks to be switched off when energy input is low. These solenoids are shown in the diagram before the heat sinks, but could be placed at the low temperature side of the sinks to reduce their operating temperature.

35

Section 300: Working Fluid Exchanger – Figure 6

If a heat transfer fluid is used to conduct energy from the solar receivers, backup heat sources or storage devices, it may be necessary to transfer the heat to a working fluid for use in a heat engine in order to generate mechanical or electrical energy. This may however not be necessary with all types of heat engines, e.g. Stirling cycle engines. The diagram shows, in section 400, a Rankine cycle engine (400), which requires steam as working fluid. The working fluid heat exchanger (300) boils the engine's working fluid using the heated transfer fluid, and makes it available to this engine.

A feed pump (310) is used to establish a flow of working fluid through the exchanger. As working fluid is boiled off, the level of the fluid in the tank will drop. The pump (310) is therefore controlled to keep an approximately constant fluid level within the heat exchanger (300) by means of the level transmitter (LT300).

No means for energy dissipation in the high temperature circuit is shown in Fig. 5. Although this can be provided for by duplication section 600 (see Fig 7) for the high temperature circuit, it would be more economical to move the solar collectors away from the sun and thereby reduce the input power. It is however expected that the maximum solar input power would always be desired, so that the heat engine may always produce electricity at the maximum rate possible. Any excess electrical energy that cannot be used or stored could be sold back into the mains electrical grid. Excess heat from the heat engine condenser would be dissipated in section 600 (Fig 7) once the medium and low temperature storage devices have reached their capacity. If the grid supply is not available, the solar collectors can be moved away from the sun.

Section 400: Main Generation – Figure 6

As mentioned above a heat engine (400) is used to convert the input heat to useful mechanical and/or electrical energy. A Rankine cycle engine is shown in the diagram, but any heat engine or cycle may be used. This includes, but is not limited to, phase change cycles, gas only cycles and liquid only cycles and includes but is not limited to Steam, Stirling and Brayton engines.

Steam from the preceding sections is accumulated in an insulated tank (410), and passed via a control valve (420) to a turbine, positive displacement or other type of

expander (400). The expander is connected to a mechanical to electrical converter (430), e.g. an alternator or generator, to produce electrical power.

5 Vapour exhaust from the expander is condensed in a condenser (450) and stored in a tank (440), which may be insulated. Heat extracted through condensation is transferred to a heat transfer fluid in the condenser (450) for use in the remainder of the system. Flow of the heat transfer fluid in the condenser (450) is established by a pump (460).

Section 500: Backup Generation – Figure 7

10

In place of, or in addition to, providing backup sources of heat at the input to the system (Section 100), backup generation of electrical or mechanical power and heat may be included after the main generation heat engine. This can be performed by an engine of any thermodynamic cycle, in which heat is generated as a by-product of the mechanical /
15 electrical power generation. Typically, an internal combustion engine using petrol, diesel or LPG / Natural Gas may be used.

The diagram shows an engine (500) connected to a generator (530). Heat transfer fluid is circulated through the engine or auxiliary heat exchanger(s) in order to extract
20 combustion heat from the engine. A pump (510) establishes this flow and it is controlled so that the engine (500) and the fluid output are at approximately constant temperature.

Additionally, the exhaust gas of the engine may be passed through a further heat exchanger (550), in order to extract additional heat from the combustion process. The
25 low temperature fluid may also be passed through the exhaust by means of another pump (560).

Section 600: Heat Dissipation – Figure 7

30 When solar input is high and demand for heat is low, excess heat will be produced. This excess can be reduced by reducing the energy input, by storing or by dissipating the heat. Since the heat is used to generate electricity or mechanical power, or is a by-product of such generation, it may be advantageous to continue the generation of electrical/mechanical power, and dissipate the heat that cannot be used or stored.

35

For this purpose a heat exchanger (600) is provided. In the diagram the heat exchanger is shown to dissipate heat to the atmosphere, but heat can be dissipated into water (e.g.

swimming pool, Jacuzzi, ocean, river and so forth), into the ground, into an industrial process, or any other useful sink.

5 A diverter valve (620) is controlled by a temperature sensor (TT620), which diverts some or all of the cold fluid return through the heat exchanger if the temperature of the fluid is above the preset value. The diverter valve and controller may either be proportional or on/off type.

10 When excess heat is available in the medium temperature circuit, the pressure in this circuit will rise and the pump (710) from the Medium Temperature Storage (see Section 700) would typically be run in reverse. This will reduce the pressure in the medium temperature circuit and store the heat in the energy storage device. If the storage device cannot store this energy (i.e. it is full), the outlet through the pump (710) would be at elevated temperature. The hot fluid would then report directly to the cold fluid return, at
15 which point the dissipater would initiate operation to ensure that the cold fluid return is at an acceptable temperature for the condenser and engine cooling requirements. This scheme will ensure that excess hot fluid always passes through the storage device, thereby ensuring that its temperature is kept as high as possible.

20 If for some reason the high temperature circuit is supplied with more energy that can be used and/or dissipated in the whole system, the solar collector(s) could be rotated away from the sun to reduce the energy input.

Section 700: Medium Temperature Storage – Figure 7

25

The operation of this section is identical to that of Section 200 (apart from the fact this is for medium temperature and Section 200 for high temperature), and will not be repeated in such detail.

30 To minimize the use of backup sources and/or generators, medium temperature heat transfer fluid is stored in a storage device (700). This storage device accepts heated fluid and stores this energy either by directly storing the heated fluid, or by transferring the heat of the fluid to other substance(s) and storing it as sensible, latent, chemical or nuclear energy within those substance(s).

35

Section 750: Low Temperature Storage – Figure 8

The operation of this section is identical to that of Sections 200 and 700 (apart from the fact this is for low temperature). The storage device is indicated as 750 in the diagram.

5

Section 800: Medium Temperature Heat Sinks – Figure 8

The diagram shows one medium temperature sink (841) linked directly to the cold return conduit. The system may contain any number of medium temperature sinks, including none. The flow through each sink is controlled by a thermostat (842), pump or any other means to ensure that the sink receives the amount of heat required. The sink can also be switched out of the circuit by valve (840). The same principle is applied to all sinks.

10

However, some medium temperature heat sinks, e.g. absorption chillers, require fluid input at elevated temperature, while their output is still at a temperature that might be useful for low temperature sinks. Thus, a cascaded system of sinks is provided for where the medium temperature sinks (821, 831) first extract heat from the fluid, and their output is then fed to the low temperature sinks.

15

The diagram shows two cascaded medium temperature sinks, although the system may contain any number of medium temperature sinks, including none.

20

The cascaded medium temperature sinks provides, together with the low temperature conduit, the energy input to the low temperature sinks (Section 900).

25

When the demand in the low temperature circuit is high, and the pressure in the circuit starts to drop, a pressure reducing valve (800) will open and additional heated fluid is admitted to the low temperature bus to satisfy the demand.

The thermostat (850) would however stop the flow in the cascaded system if the temperature on the cold side of the cascaded medium temperature sinks drop below a pre-set value. This will prevent cold fluid being passed to the low temperature heat sinks. In this situation, energy from the low temperature storage device will be used to satisfy the demand in the low temperature circuit.

30

35

Conversely, a pressure relief valve (810) will open when the flow of the medium temperature sinks are higher than the low temperature sinks, so that the low temperature fluid conduit pressure exceeds a preset value. Heated fluid is then dumped directly to the

cold fluid return. The energy of the heated fluid will not be lost, since an increase in temperature of the cold fluid return will lead to an increased flow rate in the medium temperature conduit. If the thermostat (850) closes due to low medium temperature heat sink outlet temperature, the relief valve (810) will also most probably open and admit the
5 fluid to the cold return conduit.

Solenoid valves (820, 830) are provided to switch the sinks in and out of the circuit. This would then also allow low-priority heat sinks to be switched off when energy input is low. These solenoids are shown in the diagram before the heat sinks, but could also be
10 placed after the sinks to reduce their operating temperature.

Section 900: Low Temperature Sinks – Figure 8

These heat sinks (921, 931, 941) accept heated fluid at low temperature. Examples
15 include space and water heaters. The flow through each sink is controlled by a thermostat (922, 932, 942), pump or any other means to ensure that the sink receives the amount of heat required.

The diagram shows three low temperature sinks (921, 931, 941), although the system
20 may contain any number of low temperature sinks, including none.

Solenoid valves (920, 930, 940) are provided to switch the sinks in and out of the circuit. This would then also allow low-priority heat sinks to be switched off when energy input is low. These solenoids are shown in the diagram before the heat sinks, but could also be
25 placed after the sinks to reduce their operating temperature.

Section 1000: Electrical and Control – Figure 9 and 10

Figures 9 and 10 show a typical electrical and control line diagram for the system. As
30 shown in Figure 9 power electronic converters (1510 to 1560) control the power sourced from all electrical-generating components in the system. The sourced energy is placed onto a bus. Electrical energy storage devices, in this instance as batteries (1000 - 1004) are attached to these.

Power flow between the common DC bus and the mains grid is controlled by a multi-
35 directional DC-AC converter (1230) and a duplication thereof (1240). More than one multi-directional AC/DC converter (1230, 1240) is used to optimise efficiency. The second converter (1240) and further duplications of 1230 are optional if increased AC

load capacity is required. These converters (1230, 1240) allow bi-directional power flow between the mains grid (1200) and the common DC bus, although separate inverters and chargers can also be used. A disconnect relay (1210) is provided, so that the system can continue supplying power to the user's loads when a power failure occurs without attempting to power off-premises equipment also connected to the grid. High power AC user equipment is connected before the disconnect relay, since the system will not be able to supply very large loads, especially not for extended periods of time. However, a configuration could be utilised that supply these high loads as well, but is not shown.

10

The remainder of the user's AC equipment (1250 to 1270 in Figure 9) is arranged in groups according to their priority to the user (1250 – High, 1260 – Medium, 1270 – Low). This allows the system to switch off low priority equipment (1270) when the system is low on stored electrical energy.

15

Similar to the AC equipment, the user's DC loads at 48V and 12V are also grouped according to priority and connected to relays (1710 – High, 1720 – Medium, 1730 – Low, in Figure 10). The system makes provision to inform the user of the switching to ensure the safe switching and intelligent equipment could be 'warned' of the eminent switching of the power.

20

As shown in Figure 10 converter (1570) provides regulated power (typically 24V) to the control system. Controller (2000) accepts all measurements and data, calculates the required flows and controls the pump motors, solenoids, and other actuators in the system.

25

System Control

The individual components in the system are controlled so that the net flow of energy into and out of each conduit is on average zero. Various control algorithms could be employed and a particular one is briefly discussed here.

30

The flow through the heat exchangers/receivers of all energy sources (solar, backup heat input or backup generation) is regulated so that the fluids exit the exchangers at an approximate constant specified temperature. Thus, the inflow of heated fluids into the system is controlled by the sun and atmospheric conditions for the solar receivers, and by the rate of fuel burn for the backup sources. Thus the system does not have direct control over the flow in the input heat exchangers. However, the system does have

35

indirect control over the heat input, for example by tracking the sun or tilting the solar collectors away from the sun, or by commanding a fuel flow rate.

5 Similarly, the flows through the sinks are not normally determined by the system, but by the requirements of the end function the sinks are to perform. The system may have full control over the flows of some sinks (e.g. sinks used for dissipation of surplus energy), but for most sinks the system will only be able to switch the sinks on and off according to their priority to the user.

10 The system controller (2000, Fig 10) does have full control over the flow through the storage devices (200, 700, 750). Thus, the storage devices are primarily used to balance the flow from the sources and sinks. If the sources of a specific circuit produce more flow than the sources accept, the relevant storage device is used to store the excess energy. Similarly, if the sinks consume more flow than the sources can provide, the storage
15 device is used to provide additional energy to the sinks.

When the situation occurs that additional energy is required and the storage devices (200, 700, 750) are depleted, additional sources need to be put into operation and/or some sinks be switched off or throttled back. Similarly, when excess energy is produced
20 but the storage devices are full, energy production needs to be decreased or the excess energy dissipated in some way. Different algorithms could be used to decide how to handle the heat flow in the storage devices.

In order to determine whether an excess or shortage of energy exists in any circuit of the
25 system, the pressure of such circuit is monitored. A rise in circuit pressure means excess energy, and a drop in system pressure a shortage of energy. The accumulators are provided as means to dampen pressure fluctuations in the system and thereby aid controllability. The same is true for the electrical sources and sinks. The common DC bus voltage is used to indicate the amount of energy available in the system, and the
30 batteries are used as storage buffer.

It is provided for that other methods could also be employed, e.g. monitoring the flow and temperature of each source and sink and performing mathematical calculations.

35 It should be noted that the individual circuits (high, medium and low temperature) in the system are interconnected through heat exchangers, resulting in the circuits being sinks or sources for each other. Thus, the heat engine circuit is a sink for the high temperature circuit, while the high temperature circuit is a source for the heat engine circuit. The

storage elements can be seen as buffers that decouple the energy inputs and outputs of the circuits from each other. This will enable, for example, the heat engine to continue to generate power, even if no solar or alternative energy sources are available.

5 Variations on the Invention

1. Improvements and Variations to the Collectors

1.1 Semi focused Collectors

This invention describes the use of a trough concentrator which focuses the sun energy on a line-receiver for direct sunlight and on a plate receiver when the sunlight is diffused. Other semi-focusing systems are well described in the literature and could also be utilised in the holistic distributed solar energy system.

1.2 Parabolic dish and trough collectors

The invention described here would also work if a parabolic dish or and trough collector/concentrator is used for elevated temperatures with or without a combination with a flat/diffused collector for lower temperatures. It should be noted that this combination of additional diffused collectors could be implemented for all the collector systems known. Trough and dish configurations in parallel or series to increase the temperature could also be employed.

1.4 Heliostat system

In some instances the holistic distributed system would need more electric power to facilitate the operation of a small factory, small village, a hostel or any type of mass housing scheme. In such a case it might make sense to utilise the concept derived in the invention to include the option to install a heliostat type system for the increased electrical load.

2. Receiver improvements and variations

2.1 Options from collector systems

As discussed in the previous part, certain improvements or variations exist for the collectors and these call for optimisation in the receivers to specially optimise each case.

2.2 Photo voltaic receivers

Photo voltaic system can be implemented in both the high and low concentrated solar systems as well as in the non concentrated receiver system. The cooling of the PV's would be used to drive the rest of the system as described in the invention.

5

3. High temperature circuit – sections

3.1 Pump Reductions

If it is assumed that the backup heat input sources will only be utilized when solar output is low or zero, flow establishing and controlling devices (e.g. pumps) may be shared
10 between Sections 000 and 100 to reduce costs. For example, pump 010 may supply both receiver 000 as well as heat exchanger 100 through a diverter valve. In this way, pumps 110, 160, 510 and 560 may be eliminated.

3.2 Return conduit

15 If the same fluid is used in both types of receivers, the cold return conduit and the transfer return conduit may be combined into one conduit.

3.3 Back-up Generation and Heat source

In some configurations either Section 100 or Section 500 could be eliminated, as these
20 two sections fundamentally perform the same function of providing additional electrical/mechanical power and heat during periods of low solar output or high demand.

3.3 Combination of Boiler and heat exchanger

If heat from the backup high temperature heat sources is not required to be stored, the
25 positions of Sections 100 and 200 may be interchanged. Boiler 100 and heat exchanger 300 may then be combined into a single device.

3.4 Heat engine

Some heat engines directly accept the high temperature heat transfer fluid from the
30 receivers, boilers and storage devices, for example a Stirling heat engine. In these cases section 300 (Heat Exchanger) is not required and may be eliminated, thereby directly connecting the heat engine and high temperature conduits., as well as the heat engine return and transfer return conduits.

3.5 Utilising solar receiver as boiler

In applications where the high temperature fluid is not to be stored, the working fluid of the heat engine may be boiled directly in receiver 000 and boiler 100. Sections 200 and 300 could then be completely eliminated. Pumps 010 and 110 would then act as feed
5 pumps for the heat engine, and the high temperature conduit would conduct vapour directly to the steam accumulator. Again this will directly connect the heat engine and high temperature conduits, as well as the heat engine return and transfer return conduits. The temperature sensors TT000 and TT100 will then be replaced or
10 supplemented with level sensors, and their attached pumps (or other flow establishment devices) controlled so that an approximately constant fluid level is maintained in the receivers and boilers.

Some heat engines as discussed in 3.4 accept the high temperature heat transfer fluid from the receivers, boilers and storage devices. In these cases sections 200 and 300
15 can be eliminated and boiler 100 is reduced to a fluid heating device with a lower operating pressure. The only pressure required is for control purposes.

3.6 Backup Generator Cooling

If the backup generator (section 500) is placed before the heat dissipater (section 600)
20 as shown in the diagram, no additional cooling means is required for the generator. If it placed after the dissipater, additional cooling may be required when heat demand is low.

3.7 Shared Electrical generation system

The backup generator and the main heat engine may share the same mechanical to
25 electrical converter. Thus, some arrangement is provided for by which both the main heat engine and the backup combustion engine is connected to the mechanical to electrical converter. This can take the form of clutches, hydraulics or any other power transmission means.

4 Medium and Low temperature circuits

4.1 Non utilisation of medium and low temperature storage devices

The heat dissipater is placed before the medium and low temperature storage devices, since this allows heated fluid to flow through the storage device to the dissipater when
5 excess energy is available. This ensures that the storage devices will always be at maximum temperature while the dissipater is in operation.

If no storage device(s) is required, such device(s) may be replaced with a pressure relief valve or a controlled solenoid valve that will allow dumping of hot fluid directly to the cold
10 return. In the case that the input power cannot be reduced (e.g. the heat engine must continue to run, even though the demand for medium and low temperature fluids is low), this valve must be actuated so that the heat dissipater can dissipate the excess energy.

The cascaded arrangement of medium and low temperature heat sinks is optional, and
15 all sinks of different temperature requirements may simply be placed in parallel. On the other hand, more than two temperature levels may be cascaded, if required. If required, each cascaded heat sink may be fitted with its own cascade thermostat (850) and pressure relief valve (810). This will ensure that the maximum amount of energy be transferred to the low temperature circuit.

20

4.2 System efficiency increase

Low temperature fluid may be used as pre-heated fluid for high temperature exchangers/receivers, to increase efficiency. This is not shown in the diagram.

4.3 Number of different temperature circuits

This invention provides for as many different temperature circuits as would optimise the overall efficiency and cost effectiveness of the system.

5 Control

5.1 Flow Control

Flow establishment and control devices, e.g. pumps 010, 060, 110, 160, etc. may be placed anywhere in the fluid conduit they service. However, to increase their reliability and extend the range of devices suitable for use, they are normally placed on the low temperature side of the heat receivers and exchangers. The pumps associated with
35 storage devices may be subjected to high temperatures when operated in reverse and

the storage device is full. To prevent this, heat dissipation devices may be included between the storage device and the pump.

5 Non-return valves on pumps are provided to prevent reverse leakage through the pumps when they are not operational. If positive displacement pumps are used, non-return valves are normally not required.

5.2 Interface control system with outside world

10 The basic system could be improved substantially by linking the system to the 'outside world', giving it information regarding the expected weather in the area and also the local or national energy conditions etc. This information could be utilised to enhance the overall operating condition of the system.

15 Typically, the control system could be linked to an outside data source / higher level control system through the means of utilising current and future technologies of communication. Examples of current available communication opportunities are: Cellular phone data communication like GSM, 3G, HSDPA, etc, Data radio links, fixed land line internet links like ADSL etc, and also data communication through the electrical power network – such systems are not yet widely implemented but promising
20 technologies exist.

5.3 Maximum demand control in network linking

The basic system indicated that the system could be linked with the electricity supplier network to pull electricity from the electricity supplier when electricity is required in the
25 system or sell surplus electricity when surplus energy is available.

This could be further enhanced with the link with the outside world in various ways. One option might be to do maximum demand control or enhancement. This would be possible when many holistic distributed solar energy systems are installed and by
30 utilising their storage capacity to supply electrical energy in peak demand periods and then to refill the storage systems in low demand times.

With the high temperature liquid system as indicated in the improvements section heat could be stored and converted to supply electricity during the maximum demand periods.

5.4 Other control algorithms

The invention was based on a control philosophy to use the pressure as the basic means of controlling the energy flow in the system.

- 5 Other options may be successfully used to control the system and this invention would not be limited to the described method.

As an example a method could be employed to measure temperatures and flows in order to calculate the heat flows in the systems, and use that as a control philosophy.

10

6. Description of energy sinks and further developments of the invention

6.1 Space Heating

- Many systems exist off the shelf and most of them utilise a heat exchange design that is based on a plate heat exchanger. Under floor heat exchange systems could also be
15 utilised. This invention provides that the heat to drive these systems could be derived from the distributed solar energy system as described.

6.2 Space Cooling

- Space cooling as currently known is based either on water evaporative systems or
20 normal heat pump air conditioning systems.

The water evaporative systems make use of the principle that when a liquid evaporates that the temperature drops. These systems have a low energy requirement but lack performance in a high humidity environment.

25

Normal air conditioners are energy intensive as they utilise the heat pump principle where the compressor is electrically driven.

- This invention provides for an air condition system that is heat driven. The technology is
30 mature, but it is not usually deployed in typical house/small building applications where electricity is available.

- The proposed air conditioning system utilises the absorption or adsorption based refrigeration principle. Heat is supplied as the energy source for the process. The
35 benefit derived from this is the fact that in the distributed system, as provided for in this

invention, the heat does not need to be converted to electricity before it is utilised to drive a cooling process. Two process steps are eliminated (heat engine and electricity generation) and this results in savings on capital as well as an increase in overall efficiency. Apart from the conversion benefits, the storage of heat is much less capital intensive and would further reduce the capital outlay.

6.3 Refrigeration and Freezers

The invention would provide the heat requirements of the refrigerators and freezers which would also be based on the absorption or adsorption process as described in the previous section. The same benefits are applicable.

6.4 Warm water requirements

Most solar systems provide warm water as a primary benefit. This invention would provide for the warm water requirements of an installation, through the high and low temperature circuits.

6.5 Distilled water

With solar energy a distillation process to provide clean drinking water is an easy addition to the system. The heat to drive the distillation process would be provided by the invention. Systems to replace valuable nutritional elements back to the distilled water are provided for. This includes minerals and vitamins etc.

6.6 Cooking Energy

Steam cooking as applied in hostels and hotels are an established and mature technology. This invention provides for the heat to be derived from the solar system's high temperature circuit. The heat can be in either the steam based system or in the high temperature liquid based system as discussed.

The high temperature circuit would provide high enough temperatures to drive a frying process.

Once again the heat is directly utilised in a heat exchange system and the two intermediate processes are eliminated with the efficiency and capital benefits.

6.7 Baking Energy (Oven)

This invention provides for heat to be utilised in a baking process. Currently most ovens are either electrically or gas driven. In the holistic distributed solar energy system the heat from the solar system is utilised to drive the energy requirements of an oven. The
5 high temperature circuit of the invention is utilised for supplying the energy requirements. Again the conversion processes are eliminated and this results in capital and efficiency enhancements.

To enhance the 'browning' effect of this solar oven, a normal flame browning device
10 could be utilised.

6.8 Dish Washing

A dish washing machine utilises electrical elements to heat the water as well as to provide heat for the drying process. This invention provides for the optimisation of dish
15 washers to utilise solar energy systems as the heat source for the heating of the water and the drying process. The dish washer would still utilise electricity for the other operations.

Once again the heat source would be direct and not part of the two process conversion
20 system with efficiency and capital benefits.

6.9 Tumble drying

As in the dish washer application, this invention provides for the heat source of the
25 tumble dryer to be sourced directly from the heat circuits of the distributed solar energy system.

The rest of the system would still utilise electricity to make the machine fully functional.

6.10 Towel and Clothes heater

This invention provides for the luxury of clothes and towel heating systems which derive
30 the heat from the solar system.

6.11 Swimming Pool Heating

The invention provides for the swimming pool to be heated by the holistic distributed
35 solar energy system. The pool could further be utilised as a heat drain for some of the

processes that requires a fairly stable low side temperature source. It could also be utilised as an energy drain when the controller determine that the system has excess heat that needs to be dissipated. In this instance the maximum temperature of the pool as programmed in the controller would be used to determine the heat dissipation capacity of the pool.

6.12 Steam driven apparatus

The invention provides for the take off points for steam driven machinery. The steam would be produced from the high temperature circuit.

6.13 Dehumidifier

Many areas need a dehumidifier as a means to create a suitable environment. The holistic distributed solar energy system provides for the utilisation of desiccant materials in a system to achieve this.

The dehumidifier works by blowing the humid air over the desiccant material which would absorb the water from the humid air, when the desiccant material is close to saturation, the system provides for heated air to be blown over the desiccant material which would remove the water from the desiccant material. This process is repeated and the required dehumidification takes place.

The energy for the heated air would be supplied by the solar system. The fans and control would still be electrically operated.

6.14 Atmospheric water generator

The invention provides for the production of water from the atmosphere. By utilising the same absorption process as indicated in the space cooling and the freezer systems, water could condensate from the atmosphere. The condensate could be purified by a reverse osmosis process or by other filtering methods which is well established.

CLAIMS

1. A solar energy collector comprising an optical solar radiation concentrator operable to direct incident solar radiation to a primary solar energy collector and
5 a secondary solar energy collector configured to collect at least some solar energy from diffuse solar radiation not directed to the primary solar energy collector.
2. A solar energy collector as claimed in claim 1 in which the optical solar radiation
10 concentrator comprises a trough reflector having a focal line for reflected solar radiation, the primary energy collector is configured to collect solar energy from direct solar radiation concentrated along the focal line and the secondary energy collector is configured to collect solar energy from diffuse solar radiation in a plane extending at least partly between the reflector and the focal line.
- 15 3. A solar energy collector as claimed in claim 2 in which the trough reflector comprises a parabolic, circular or similar shaped trough reflector.
- 20 4. A solar energy collector as claimed in claim 2 or 3 in which the primary collector comprises a line receiver or a series of point receivers arranged in a line, and the secondary collector comprises a plate receiver or a series of line receivers arranged in a plane to form a plate receiver.
- 25 5. A solar energy collector as claimed in claim 4 in which at least one of the line receivers in the plate receiver comprises a series of point receivers arranged in a line.
- 30 6. A solar energy collector as claimed in claims 1 to 5 in which the line or point receivers forming the primary collector each comprises a fluid conduit which presents fluid to the focal line and is configured to heat the fluid; and the plate, line or point receivers forming the secondary collector each comprises a fluid conduit which presents fluid to the plane of the secondary collector and is configured to heat the fluid.
- 35 7. A solar energy collector as claimed in claim 6 in which the fluid in the primary collector fluid conduit is heated to a first or a second temperature, and the fluid in the secondary collector fluid conduit to a third temperature wherein the first

temperature is greater than the second temperature, and the second temperature is greater than the third temperature.

- 5 8. A solar energy collector as claimed in claim 6 in which the fluid in the primary collector fluid conduit is heated to a first and a second temperature, and the fluid in the secondary collector fluid conduit to a third temperature wherein the first temperature is greater than the second temperature, and the second temperature is greater than the third temperature.
- 10 9. A solar energy collector as claimed in claim 6 in which one or both of the primary and secondary collectors include photovoltaic cells configured to generate electrical energy and to transfer collected solar energy to the fluid conduit associated with it.
- 15 10. A solar energy collector as claimed in any one of claims 1 to 9 in which the secondary collector extends in a plane between the focal line and the bottom of the through.
- 20 11. A solar energy collector as claimed in any one of claims 1 to 10 in which the secondary collector extends in a plane above the focal line.
- 25 12. A solar energy collector as claimed in any one of claims 6 to 11 in which the fluid in the in the fluid circuits comprise a gas, liquid or a vapour.
- 30 13. A solar energy collector as claimed in any one of claims 1 to 12 in which the optical solar radiation concentrator comprises a Fresnel lens.
- 35 14. A solar energy system which includes at least a solar energy collector, any one or more of a high temperature fluid circuit for fluid at about the first temperature, a medium temperature fluid circuit for fluid at about the second temperature, and a low temperature fluid circuit for fluid at about the third temperature, wherein the high and medium temperature circuits are connected to high or medium temperature heat sinks to operatively utilize heat from the high or medium temperature fluid circuits, alternatively or in addition to a heat engine to operatively generate electricity, and the low temperature circuit is connected at least to a low temperature heat sink to operatively utilize heat from the low temperature fluid circuit.

15. A solar energy system as claimed in claim 14 which the solar energy collector comprises a solar energy collector as claimed in any one of claims 1 to 13.
- 5 16. A solar energy system as claimed in claim 14 in which fluid is collected from the output side of the heat engine at a temperature lower than the first temperature and introduced into the medium or low temperature circuits.
- 10 17. A solar energy system as claimed in claims 14 or 16 in which the high temperature circuit includes a high temperature energy storage device, preferably a fluid or alternative energy storage medium, including salt, energy storage device, alternatively or in addition to a high temperature backup energy generator.
- 15 18. A solar energy system as claimed in claim 17 in which the high temperature backup energy generator converts a fuel to heat or alternative energy storage media, which is used to heat the fluid in the high temperature circuit.
- 20 19. A solar energy system as claimed in claim 18 in which the backup energy generator utilizes a gas fuel and comprises a heat engine.
- 25 20. A solar energy system as claimed in any one of claims 14 to 19 in which the high temperature heat sinks include one or more of cooking, baking and drying apparatus.
- 30 21. A solar energy system as claimed in any one of claims 14 to 20 in which the medium temperature circuit includes a medium temperature energy storage device, preferably a fluid or alternative energy storage medium, including salt, energy storage device, alternatively or in addition to a medium temperature backup energy generator.
- 35 22. A solar energy system as claimed in claim 21 in which medium temperature backup energy generator converts a fuel to heat or alternative energy storage media, which is used to heat the fluid in the medium temperature circuit.
23. A solar energy system as claimed in claim 22 in which in which the backup energy generator utilizes a gas fuel and comprises and comprises an internal combustion engine.

24. A solar energy system as claimed in any one of claims 14 to 21 in which the medium temperature heat sinks comprise one or more of refrigeration, space cooling and dehumidifying apparatus.
- 5 25. A solar energy system as claimed in any one of claims 14 to 24 in which the low temperature circuit includes a low temperature energy storage device, preferably a fluid or alternative energy storage medium, including salt, energy storage device.
- 10 26. A solar energy system as claimed in any one of claims 14 to 25 in which the low temperature heat sink comprise one or more of space heating and water heating apparatus, including but not limited to swimming pool water heating.
- 15 27. A solar energy system as claimed in any one of claims 14 to 26 in which the high, medium and low temperature circuits include control means for the respective heat sinks, including valves, thermostats and pumps, the valves include control and shut-off valves and the pumps include positive displacement pumps.
- 20 28. A solar energy system as claimed in any one of claims 14 to 27 which includes a heat dissipater.
- 25 29. A solar energy system as claimed in any one of claims 14 to 28 which includes electrical energy storage devices, preferably batteries and capacitance storage devices, and a generator connected to a heat engine.
- 30 30. A solar energy system as claimed in any one of claims 14 to 29 which includes solar radiation tracking means and control and drive means configured to track the sun and manipulate the orientation of the optical solar radiation concentrator in respect of the sun to optimise the collection of solar energy.
- 35 31. A solar energy system as claimed in any one of claims 14 to 30 which includes control means to balance the pressure in the high, medium and low temperature circuits, the control means including pressure and flow regulators utilizing pressure, flow and temperature data.
32. A solar energy system as claimed in claim 31 in which the pressure in the system is controlled by measuring temperature in the system and using feedback control

to the various circuits thereby balancing energy flow in the system, and including pressure accumulators to control sudden pressure changes in the system.

5 33. A solar energy system as claimed in any one of claims 14 to 32 which includes communication means configured to allow the system to communicate with a remote controller and receive at least receive data in respect of energy availability and current and expected energy consumption data for a predetermined geographical area within which the system is located from the remote controller, to process the data and manage the energy utilization of the system accordingly.

10 34. A solar energy system as claimed in claim 33 in which the system also transmits data in respect of energy availability and current and expected energy consumption of the system to the remote controller for incorporation in the data available from the remote controller.

15 35. A solar energy system as claimed in claims 33 or 34 in which the communication means comprises a communication channel utilizing any one or more of the Internet, mobile telephone technology, including GSM, 3G, and HSDPA, land line telephony systems, radio communication systems or communication through electrical power networks.

20 36. An energy supply system comprising an electricity supply network in respect of a predefined geographical area, which includes a plurality of electricity consumers of which at least one consumer has a solar energy system as claimed in any one of claims 14 to 35 installed and operational at its premises, wherein the energy supply system receives data from the solar energy system in respect of at least its current usage requirements and the energy supply system utilizes this data to make a determination of the total current energy requirement of the electricity supply network in respect of the geographical area.

25 37. An energy supply system as claimed in claim 36 in which a plurality of consumers have solar energy systems as claimed in any one of claims 14 to 35 installed and operational at their premises.

30 38. An energy supply system as claimed in any one of claims 36 to 37 in which the data provided to the energy supply system includes data with respect to expected

usage requirements and current and expected energy surpluses, and for the energy supply system to obtain surplus energy from the solar energy system.

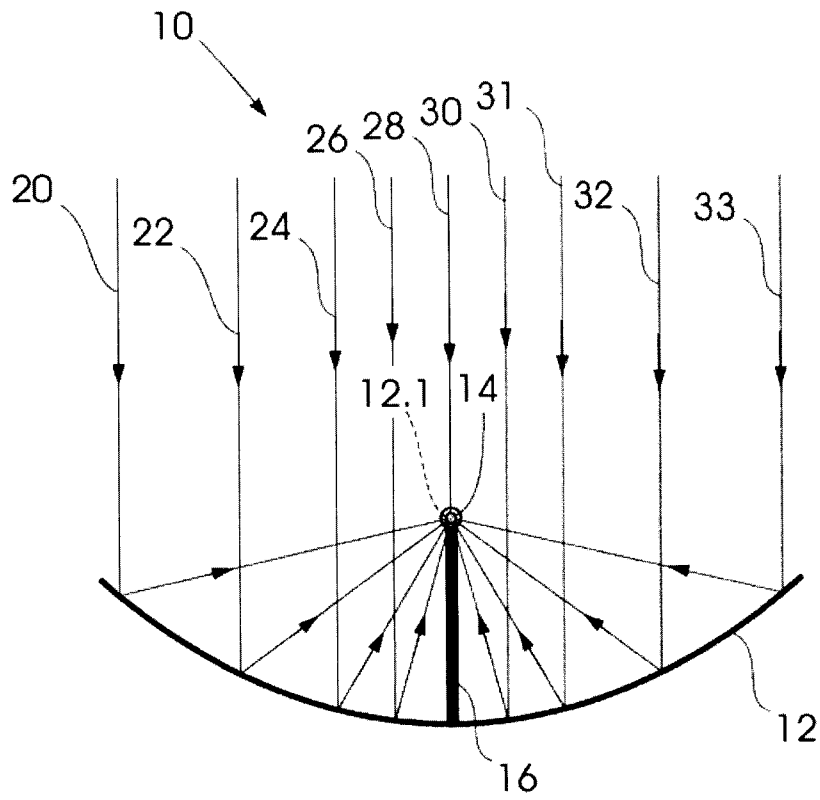

FIGURE 1

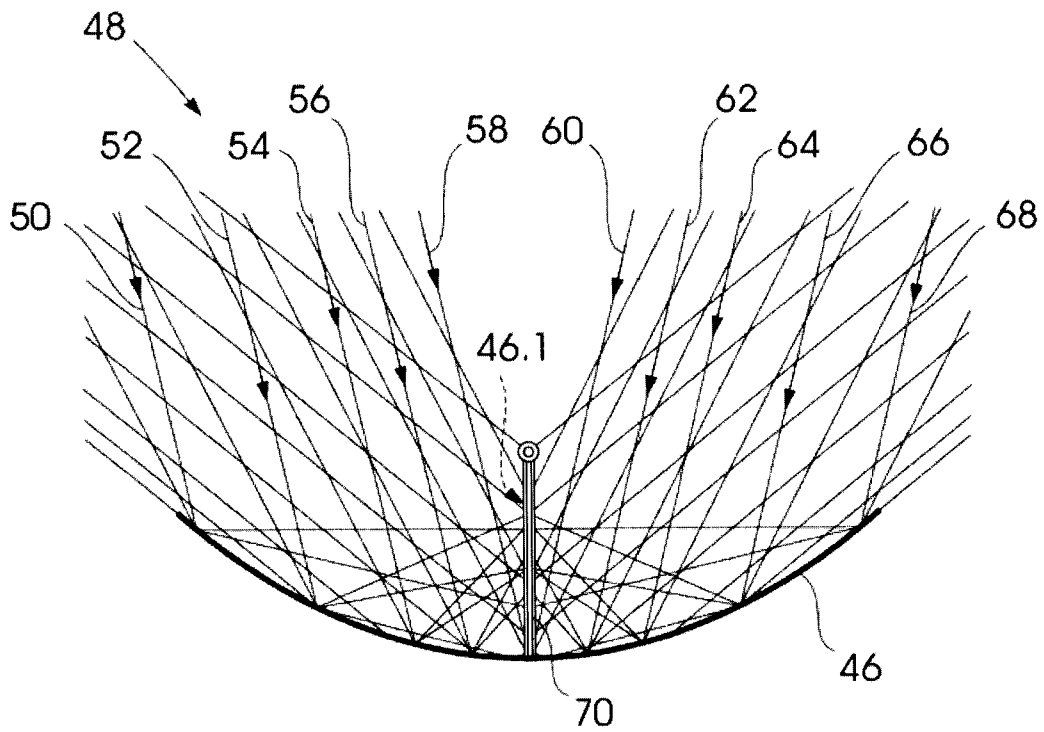

FIGURE 2

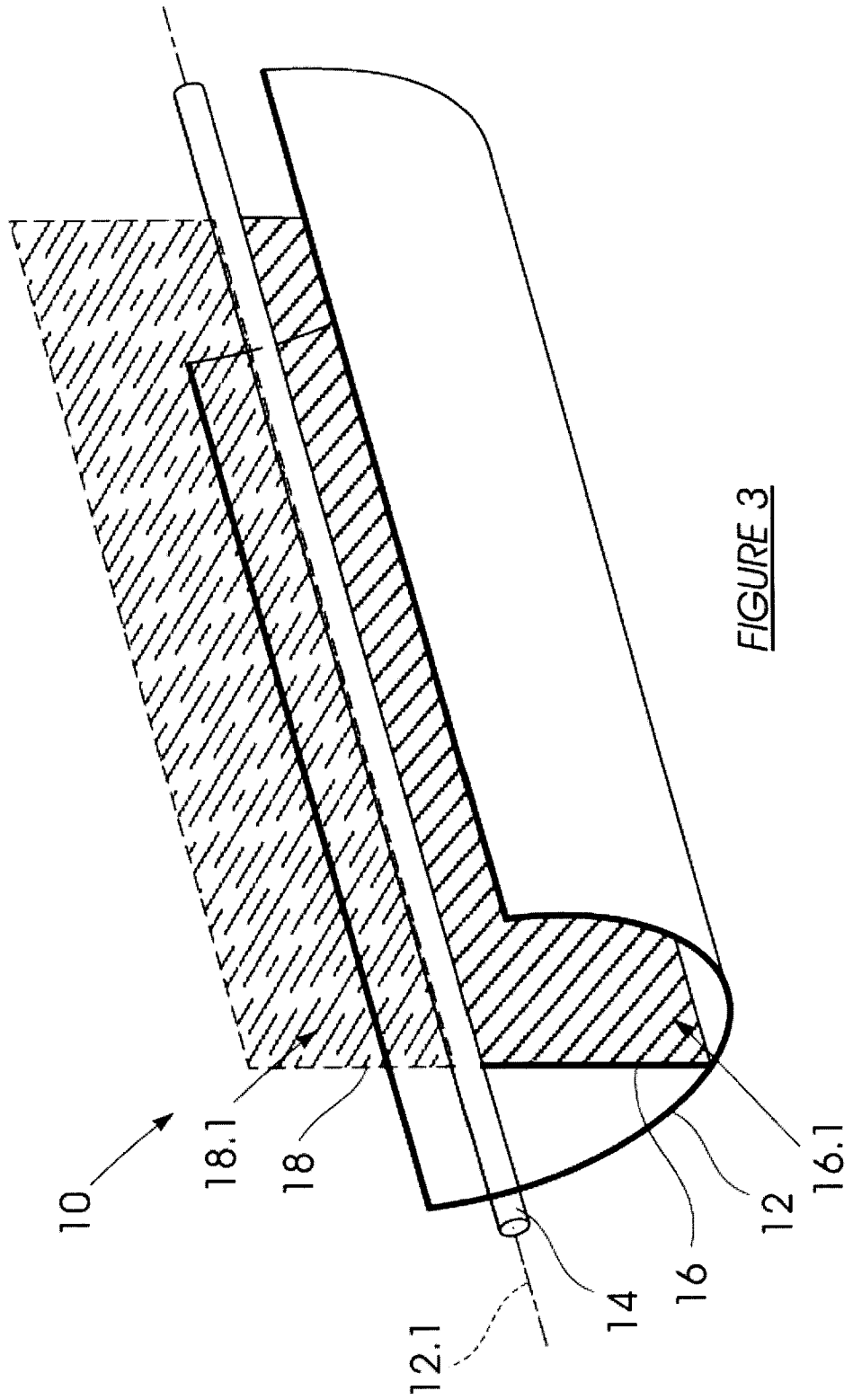

FIGURE 3

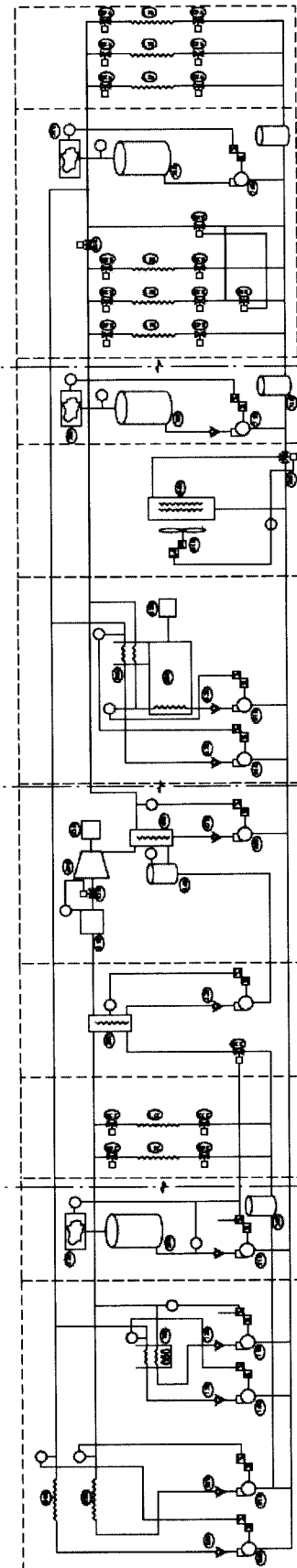

FIGURE 4

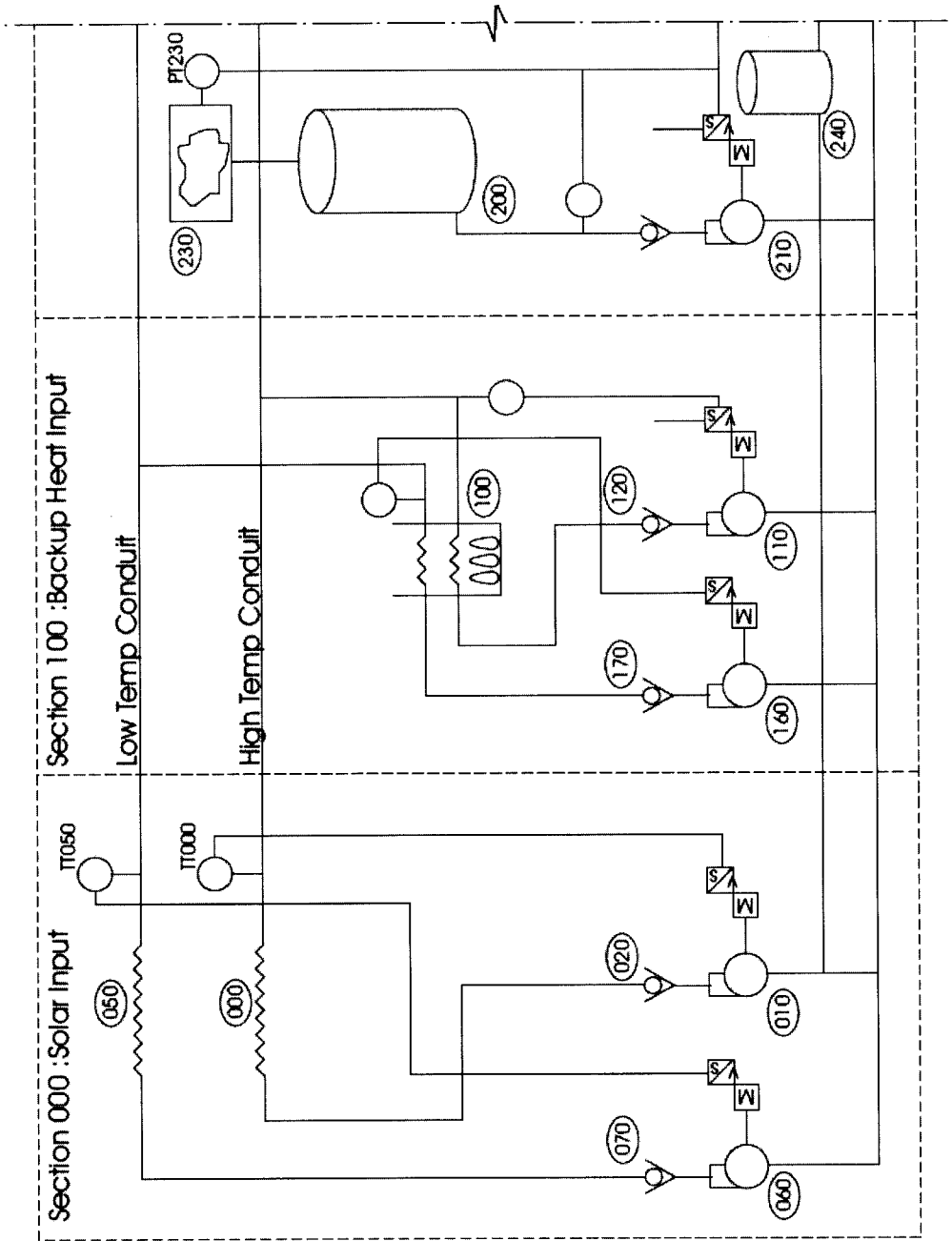

FIGURE 5

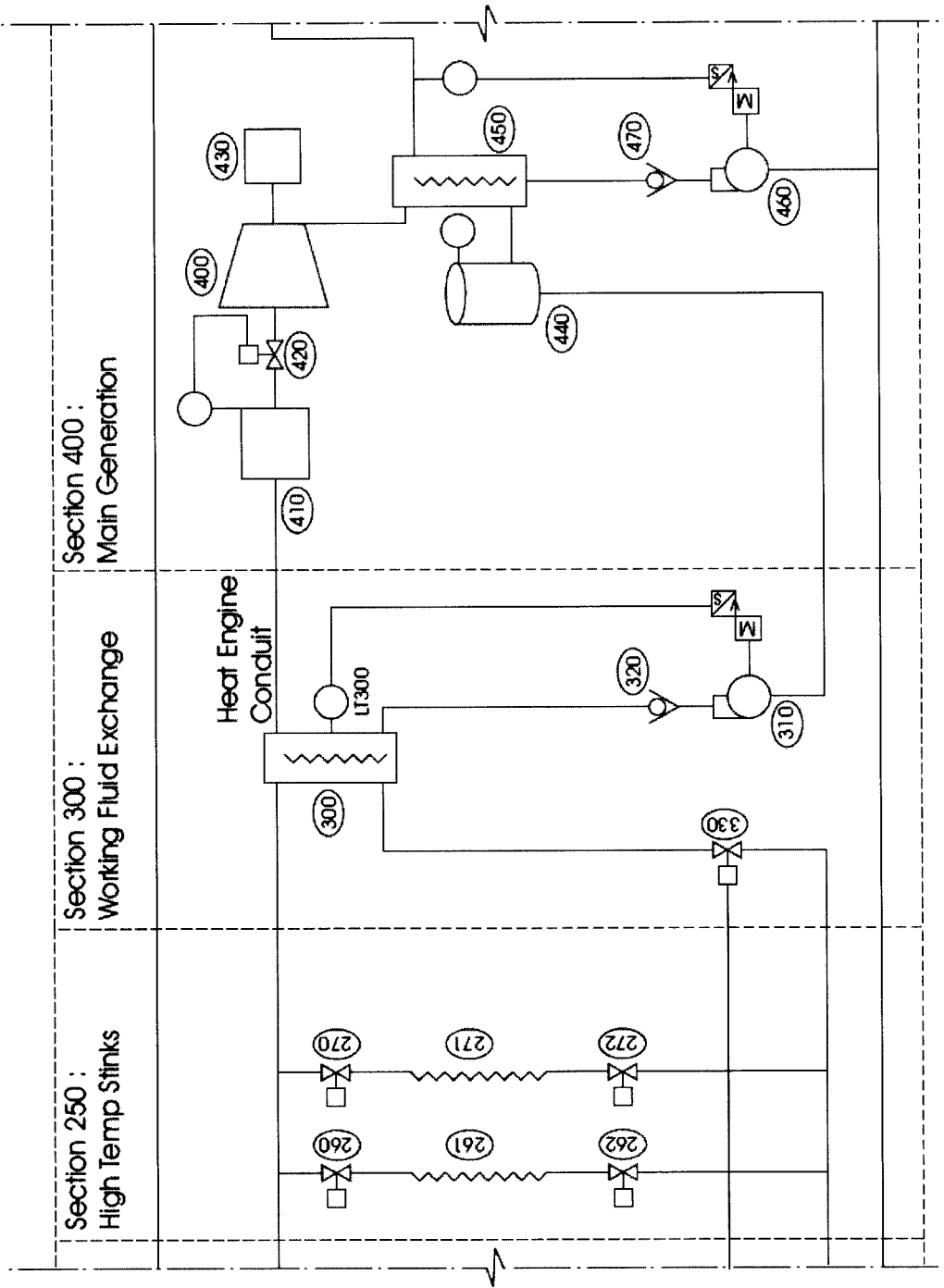

FIGURE 6

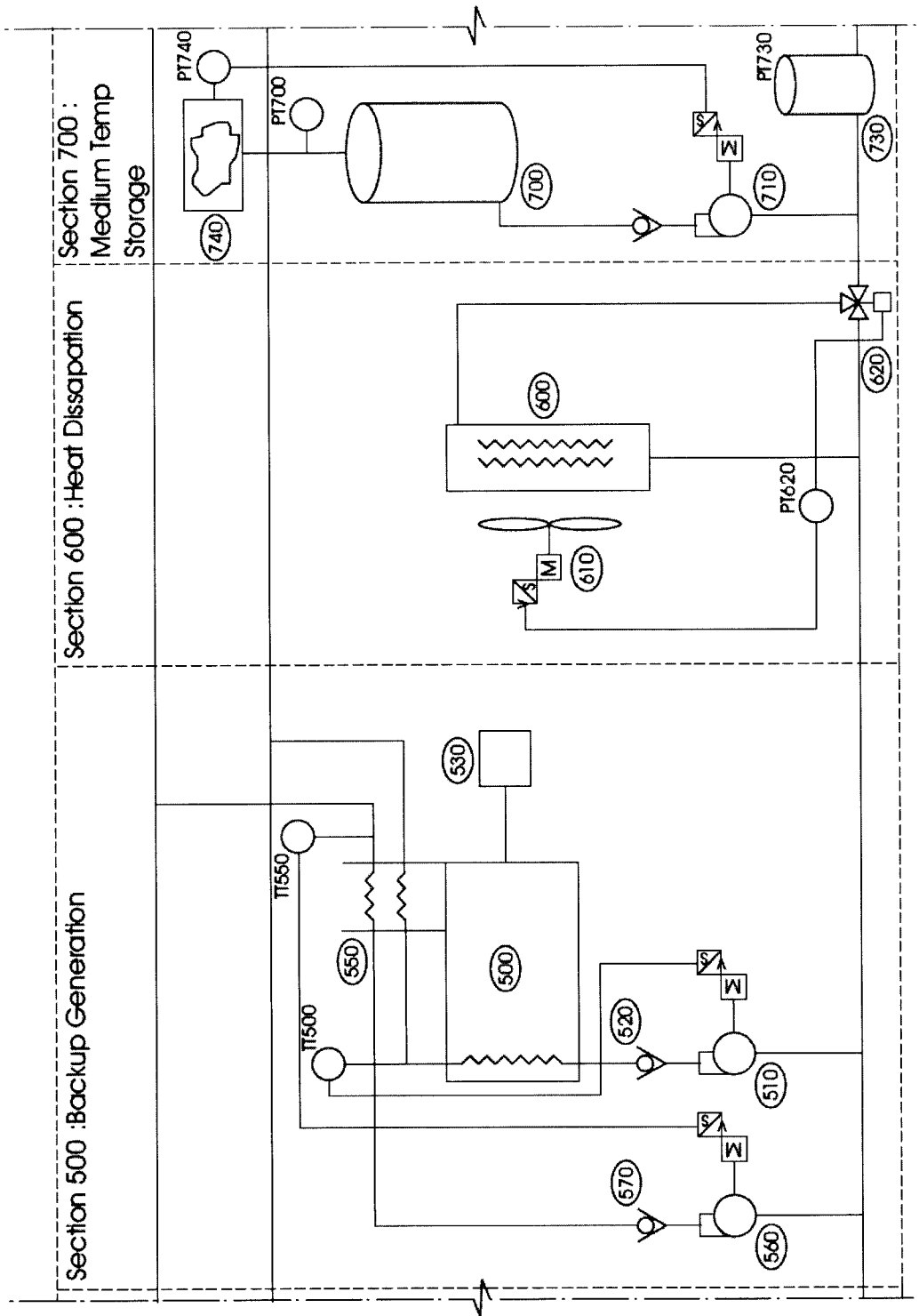

FIGURE 7

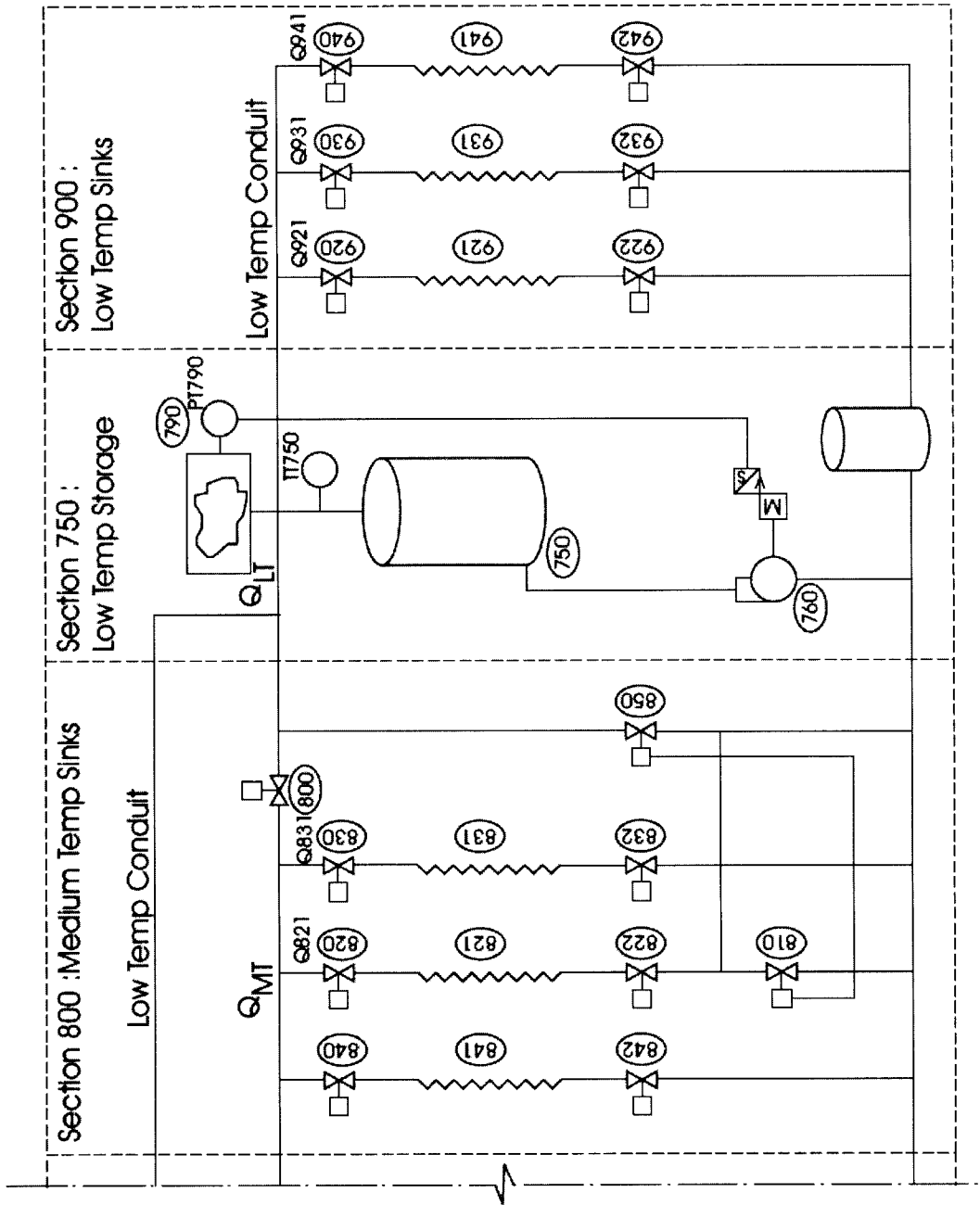

FIGURE 8

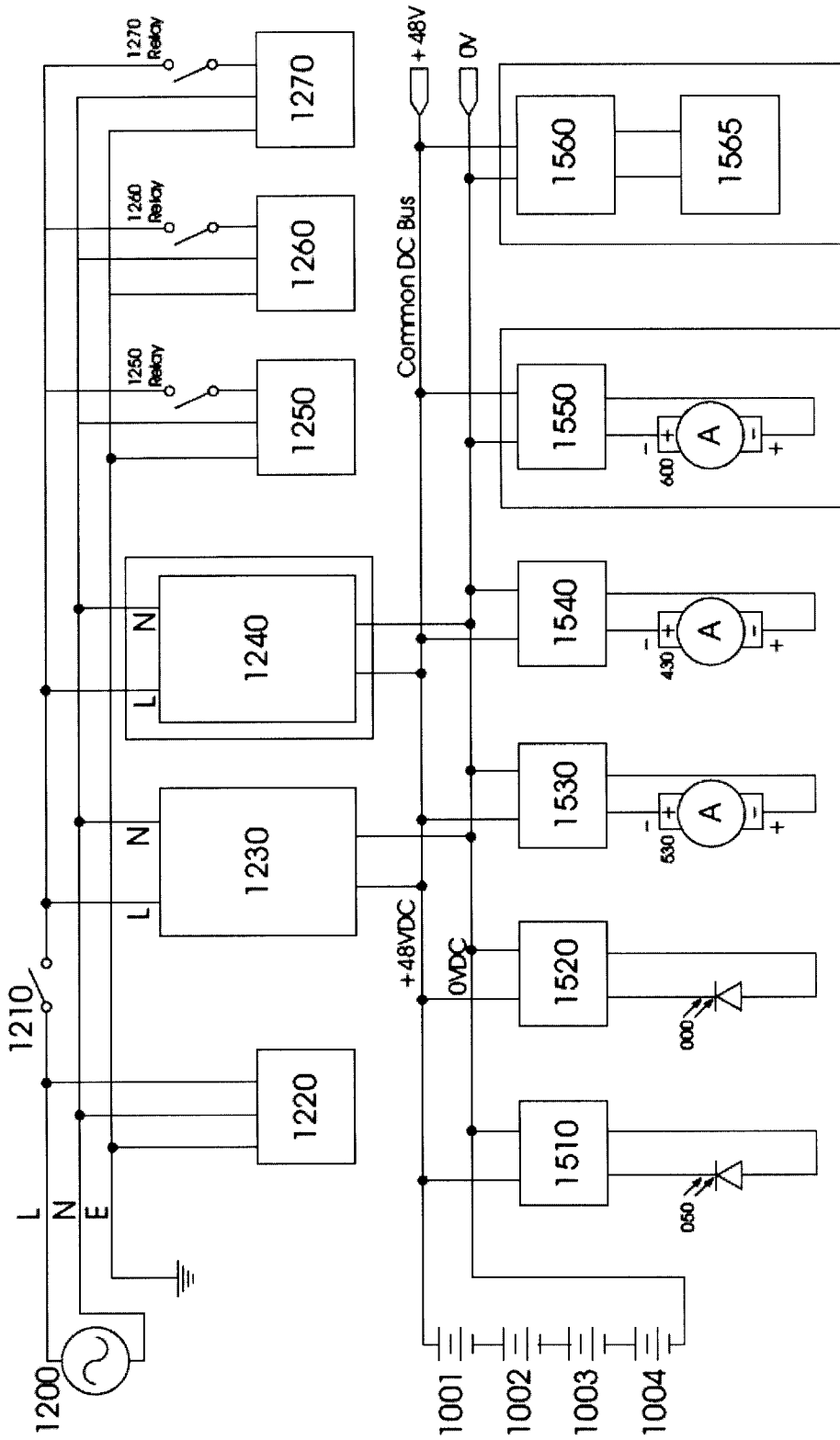

FIGURE 9

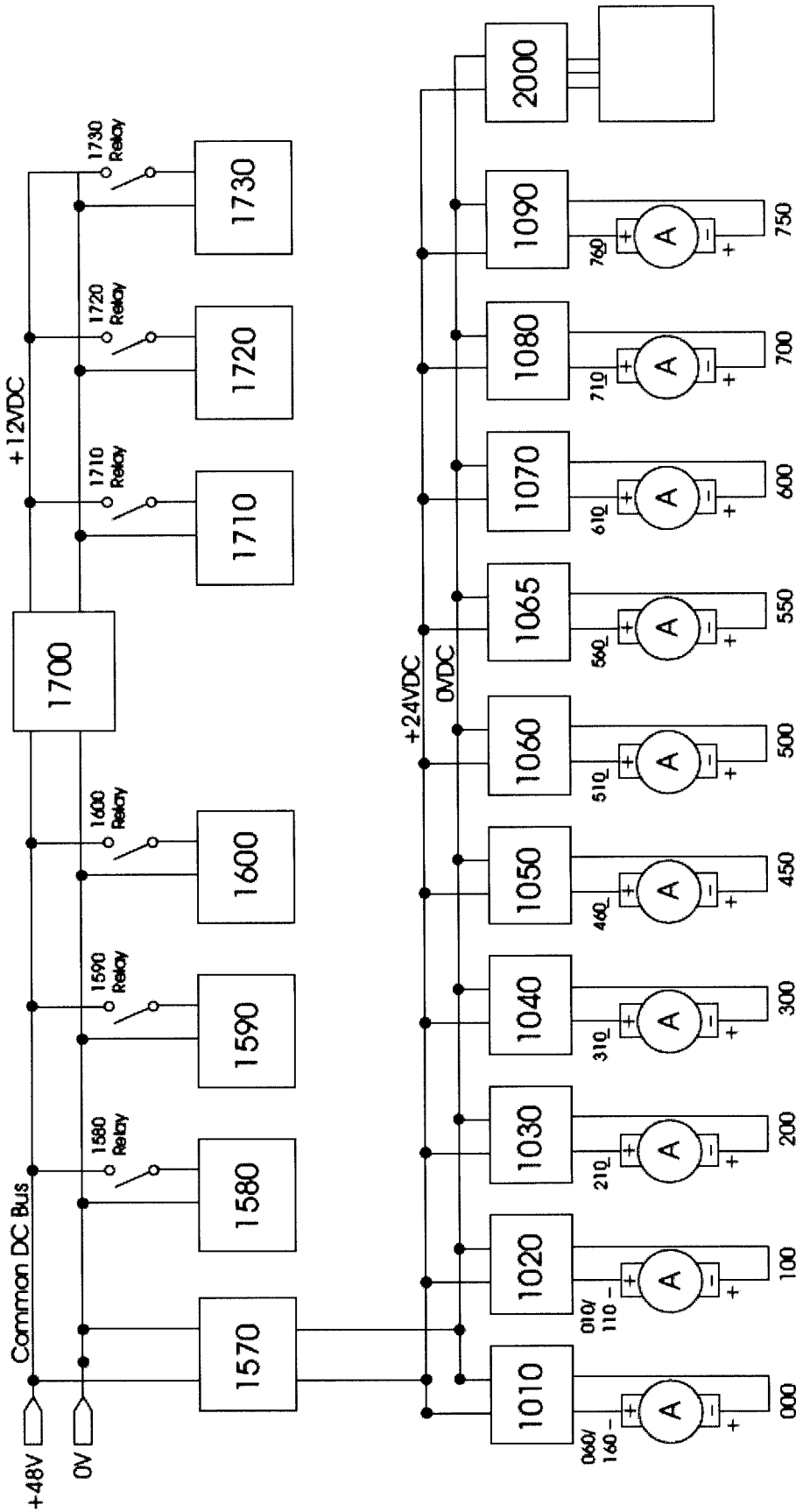

FIGURE 10