



US007263249B2

(12) **United States Patent**  
**Suzuki**

(10) **Patent No.:** **US 7,263,249 B2**

(45) **Date of Patent:** **Aug. 28, 2007**

(54) **OPTICAL ELEMENT ASSEMBLY AND METHOD OF MAKING THE SAME**

(75) Inventor: **Akiko Suzuki**, Akishima (JP)

(73) Assignee: **Japan Aviation Electronics Industry Limited**, Tokyo (JP)

(\*) Notice: Subject to any disclaimer, the term of this patent is extended or adjusted under 35 U.S.C. 154(b) by 0 days.

(21) Appl. No.: **11/453,367**

(22) Filed: **Jun. 14, 2006**

(65) **Prior Publication Data**

US 2006/0245041 A1 Nov. 2, 2006

**Related U.S. Application Data**

(62) Division of application No. 10/806,579, filed on Mar. 22, 2004, now Pat. No. 7,110,630.

(30) **Foreign Application Priority Data**

Mar. 27, 2003 (JP) ..... 2003-087895

(51) **Int. Cl.**

**G02B 6/12** (2006.01)

**G02B 6/26** (2006.01)

(52) **U.S. Cl.** ..... **385/14**; 385/15; 385/52

(58) **Field of Classification Search** ..... 385/14, 385/15, 52

See application file for complete search history.

(56) **References Cited**

U.S. PATENT DOCUMENTS

5,675,684 A \* 10/1997 Hirataka et al. .... 385/88

2001/0055447	A1 *	12/2001	Delprat et al. ....	385/50
2002/0097962	A1 *	7/2002	Yoshimura et al. ....	385/50
2003/0210873	A1 *	11/2003	Moretti .....	385/89
2004/0017877	A1 *	1/2004	Hartel et al. ....	376/283
2004/0218870	A1 *	11/2004	Blauvelt et al. ....	385/50
2005/0207695	A1 *	9/2005	Ogawa et al. ....	385/14

**FOREIGN PATENT DOCUMENTS**

JP	08-313756	11/1996
JP	09-005586	1/1997
JP	4005005586 A *	1/1997
JP	09-281360	10/1997
JP	2002-014258	1/2002

\* cited by examiner

*Primary Examiner*—K. Cyrus Kianni

(74) *Attorney, Agent, or Firm*—Larry Mendenhall; Gallagher & Lathrop

(57) **ABSTRACT**

A V-groove is formed in a platform of single crystal silicon by anisotropic wet etching based on its crystal orientation, and a convexity of an optical element chip is fitted in an intermediate portion of the V-groove. Quadrangular frustoidal convexities are formed in rows and columns on a single crystal silicon wafer by anisotropic wet etching, then a photonic crystal filter element is formed as an optical element on the protruding end face of each convexity, and the wafer is cut for each optical element into individual optical element chips. When optical fibers are disposed in the V-groove at both sides of the chip, cores of the optical fibers and light inlet and outlet ports of the optical element are aligned with each other.

**3 Claims, 14 Drawing Sheets**

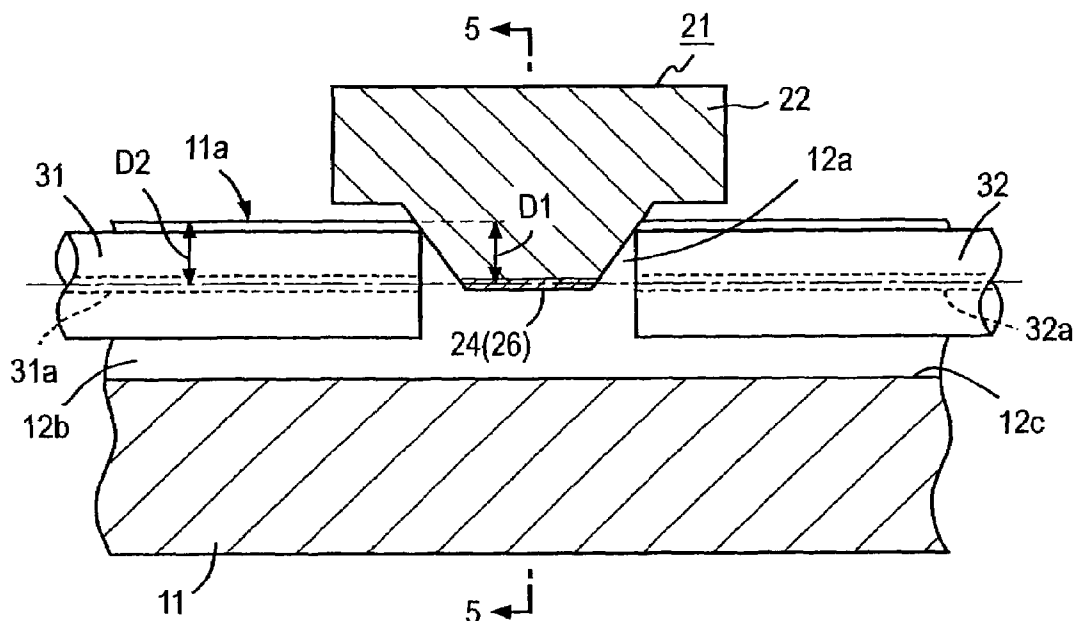

FIG. 1 PRIOR ART

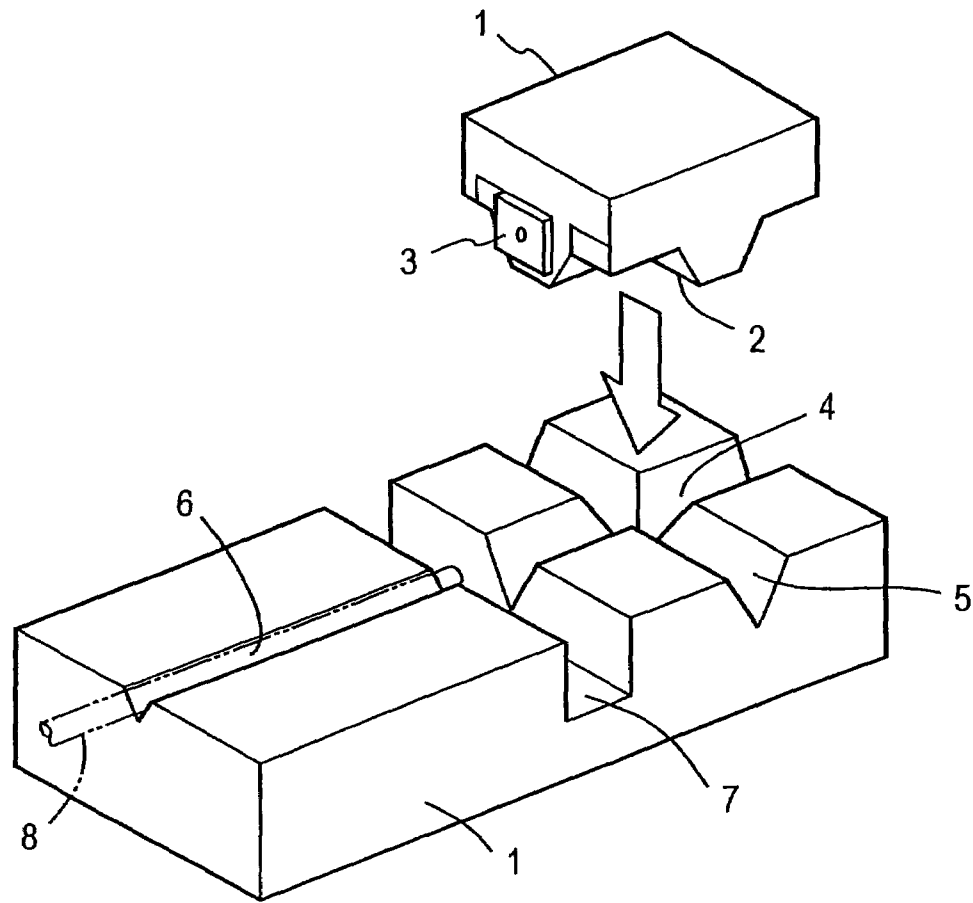

FIG. 2

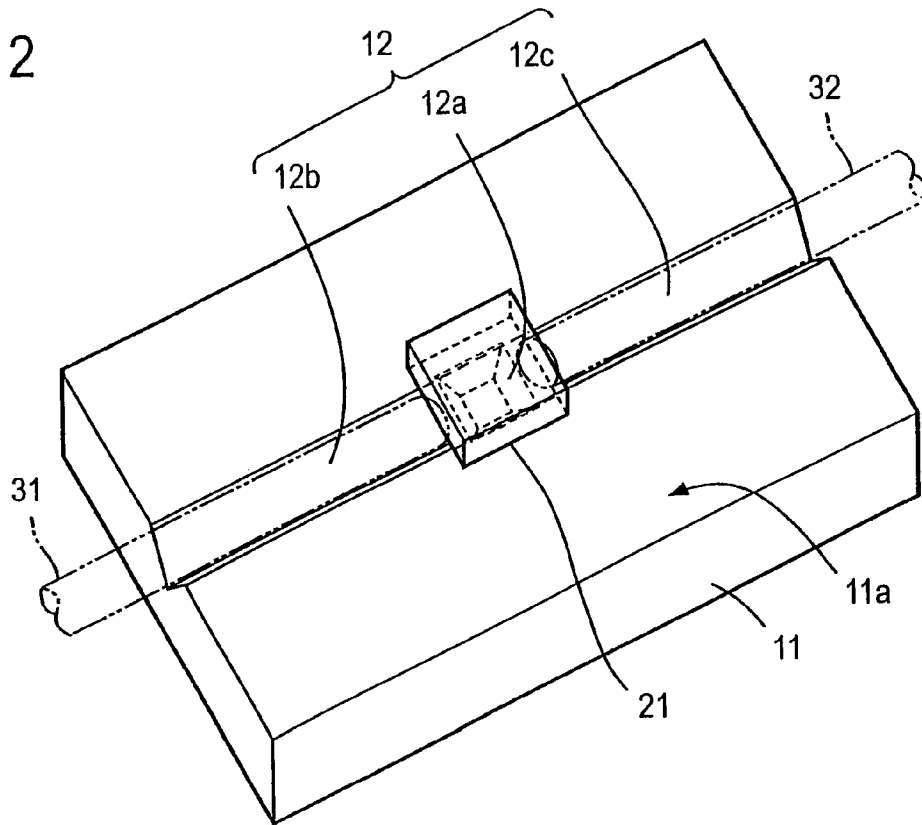

FIG. 3

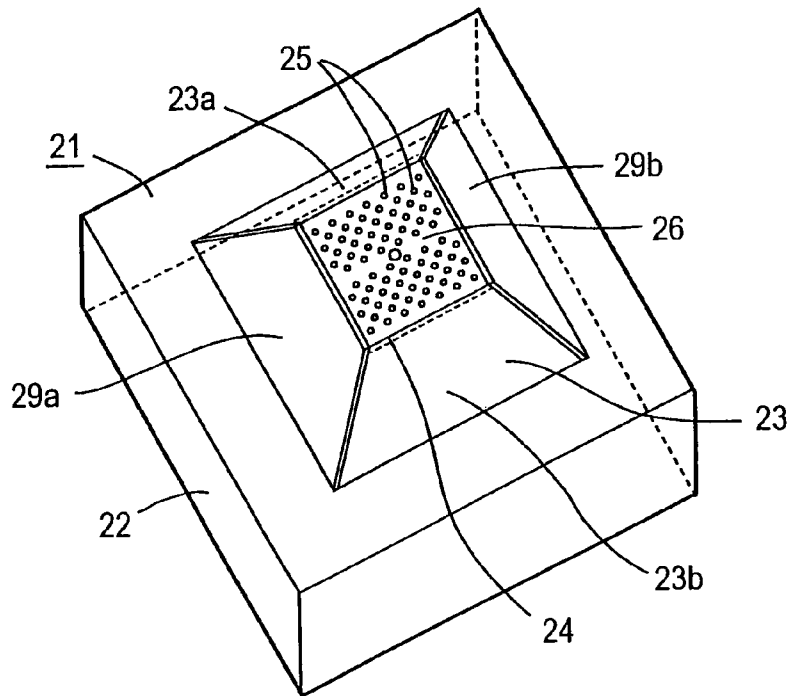

FIG. 4

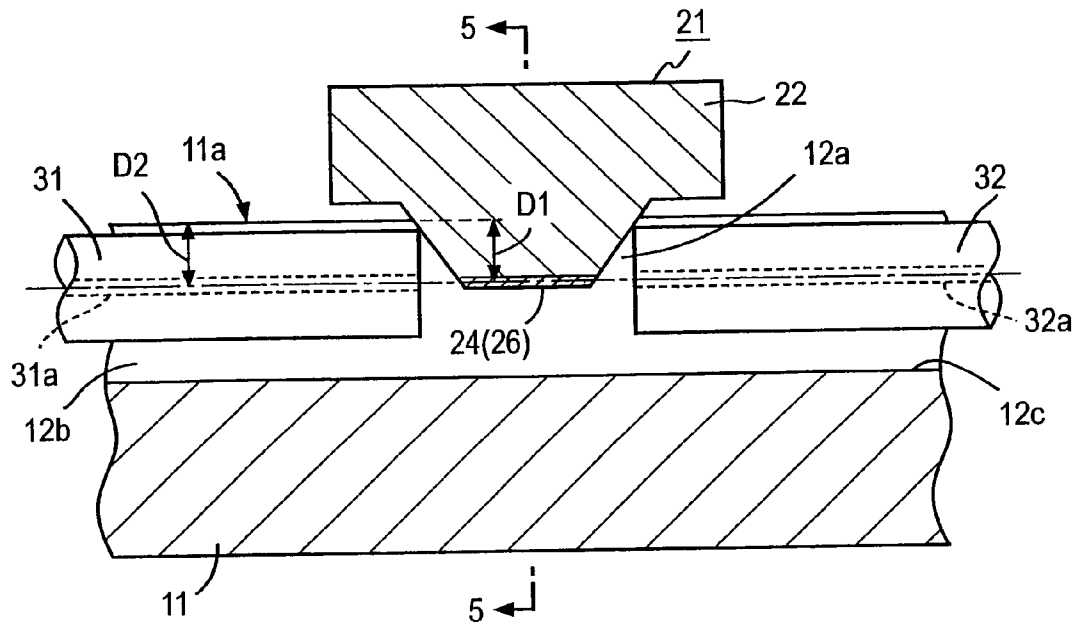

FIG. 5

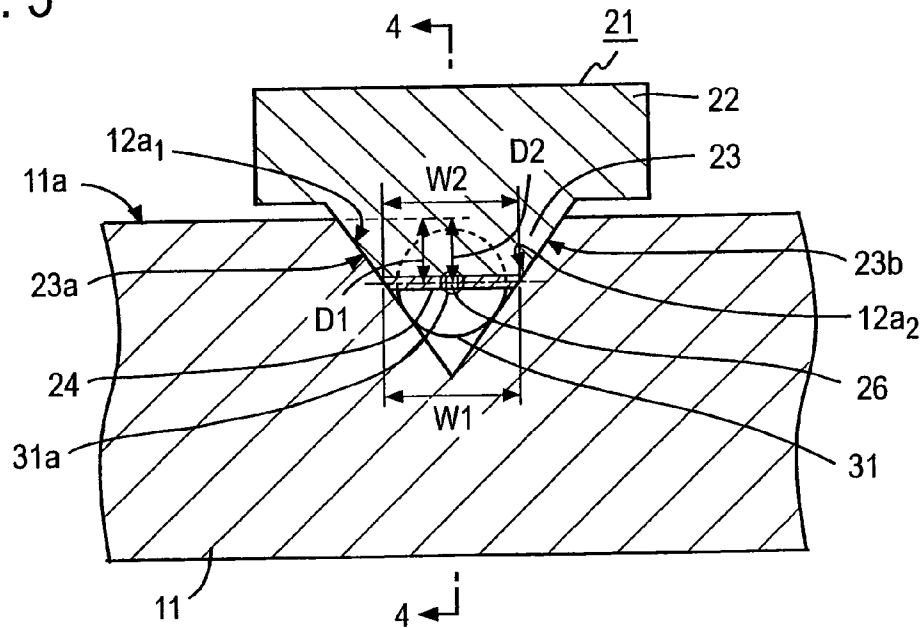

FIG. 6A

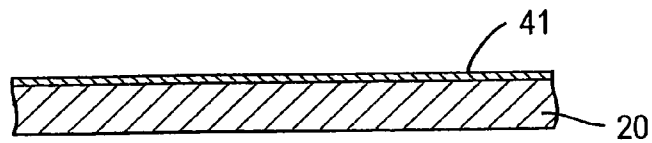

FIG. 6B

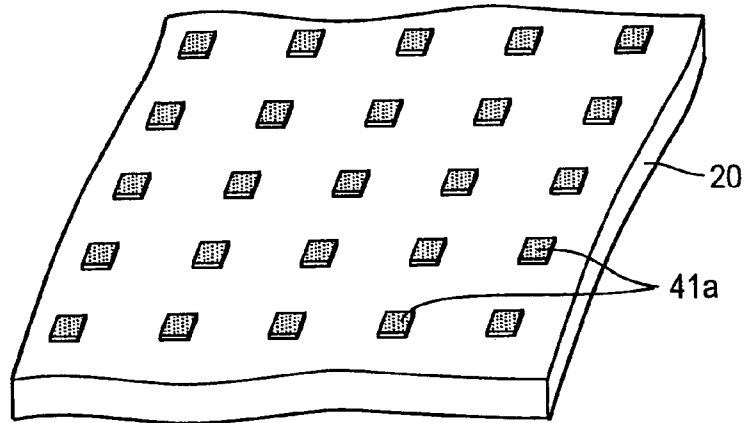

FIG. 6C

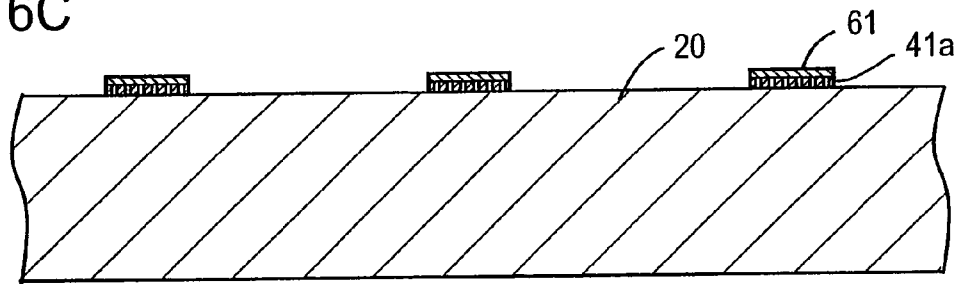

FIG. 6D

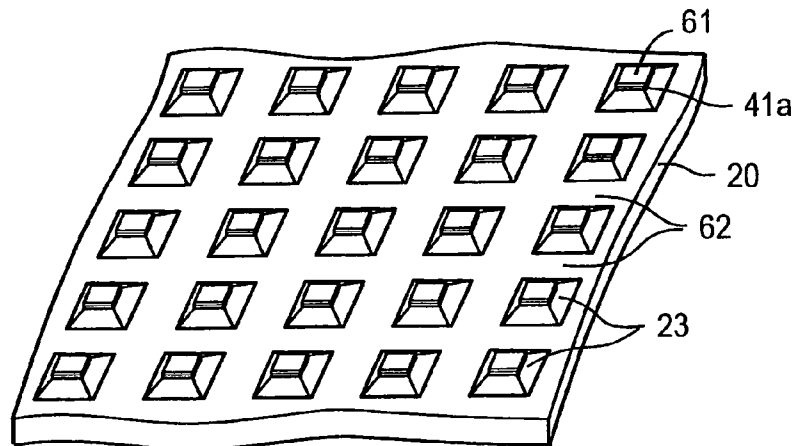

FIG. 6E

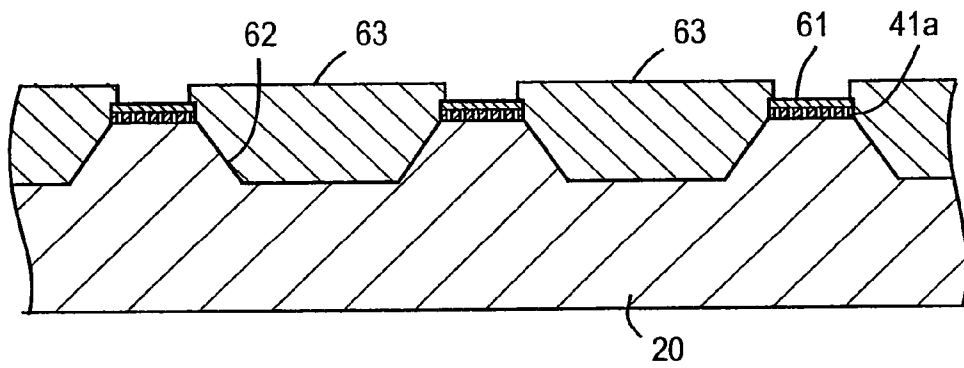

FIG. 6F

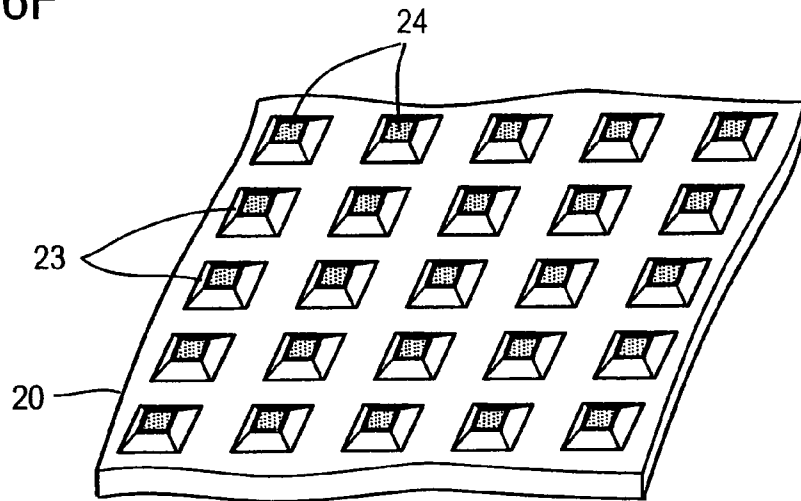





FIG. 11

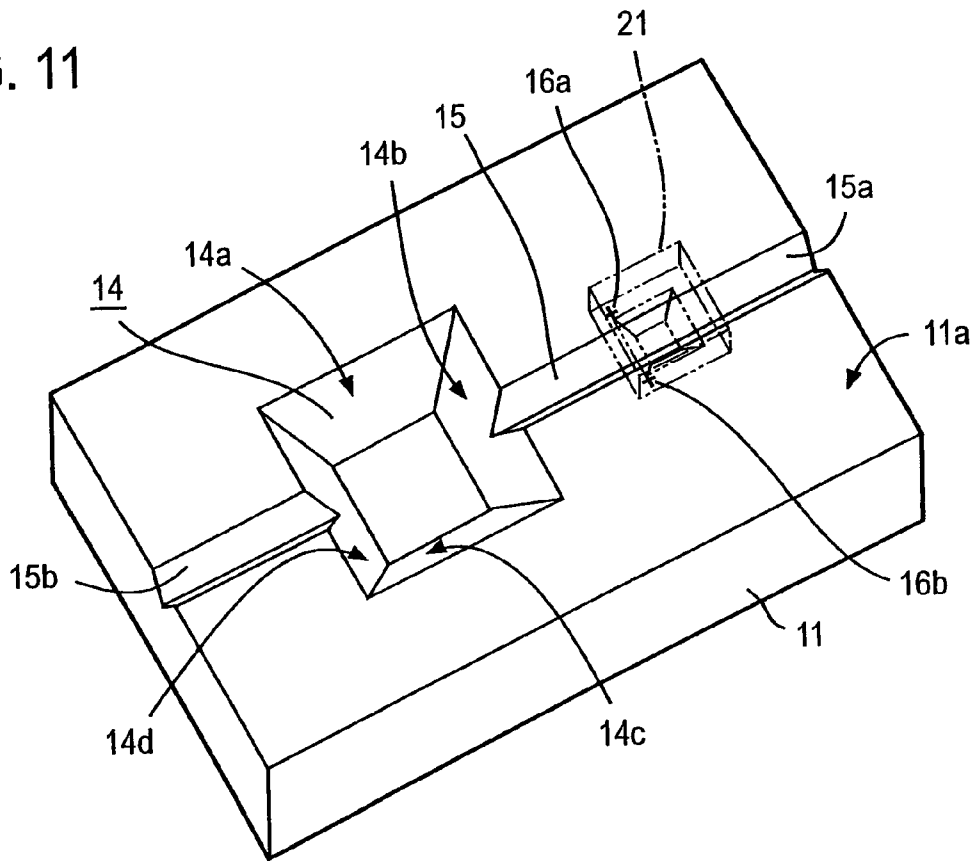

FIG. 12

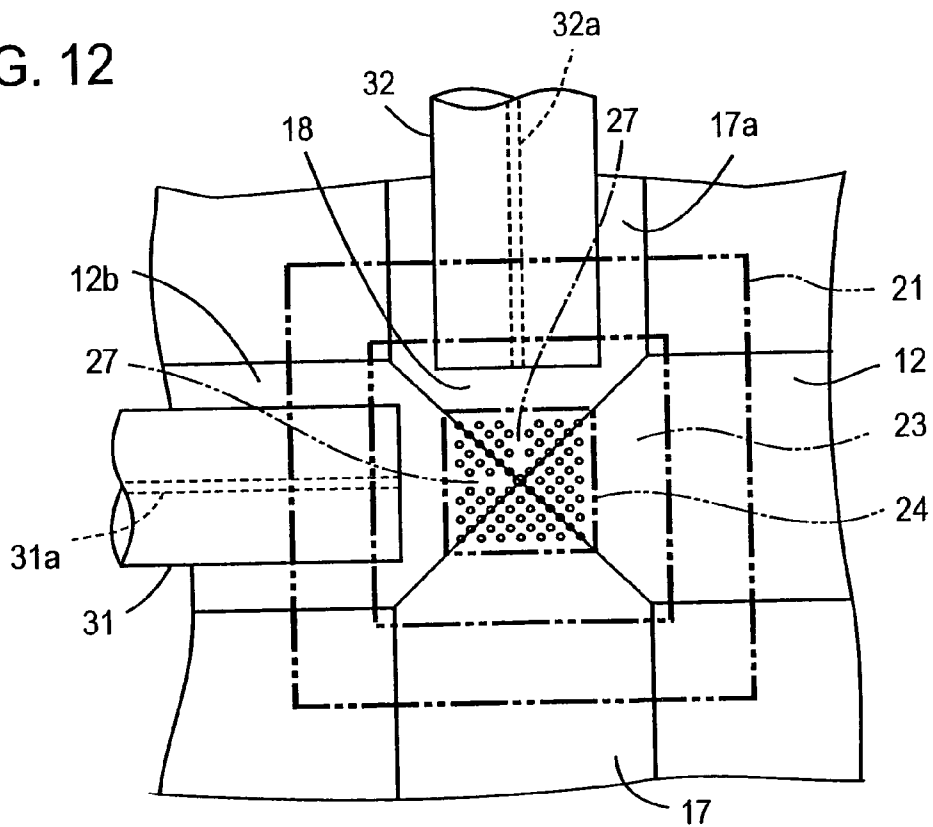

FIG. 13

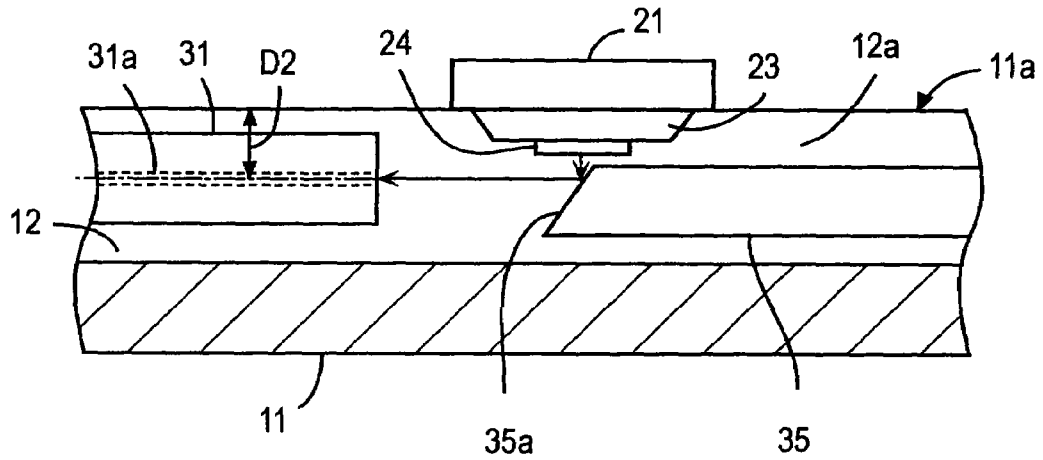

FIG. 14

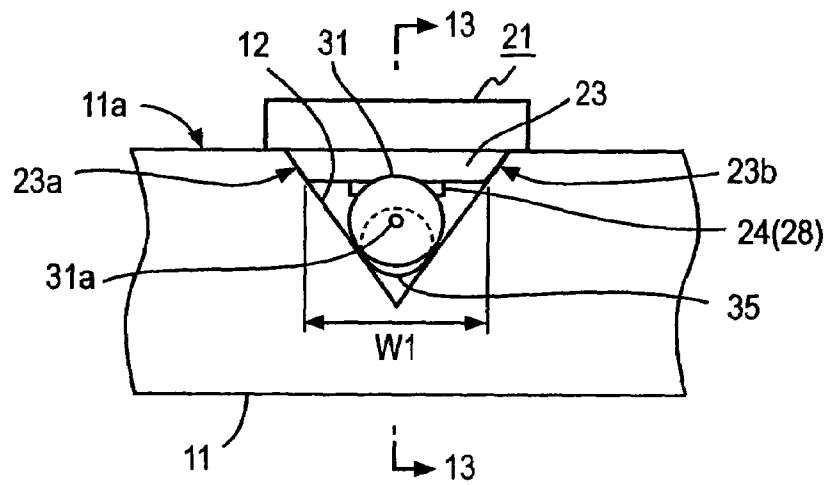

FIG. 15

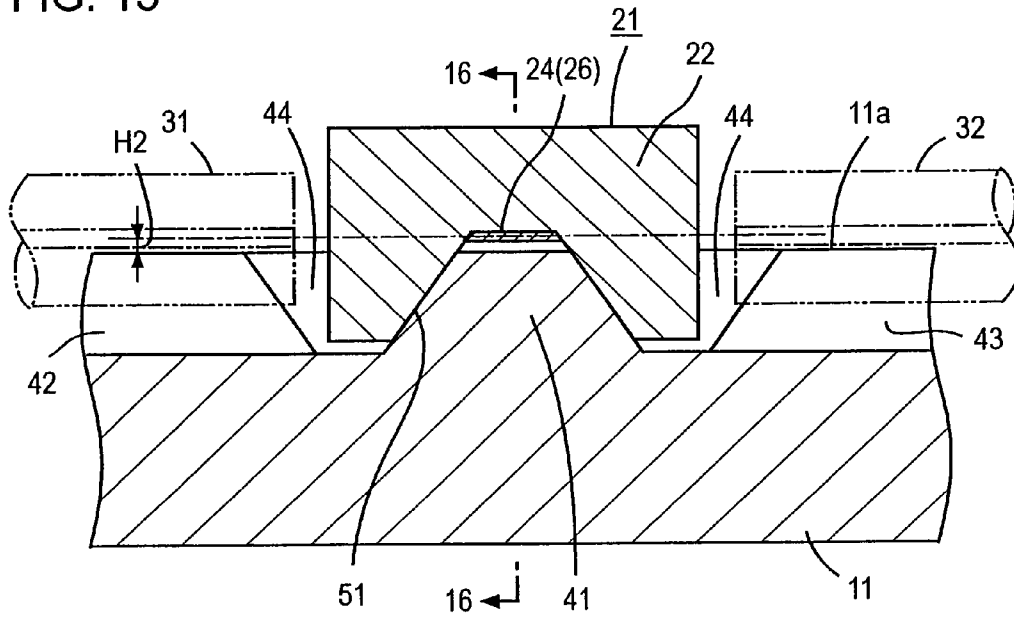

FIG. 16

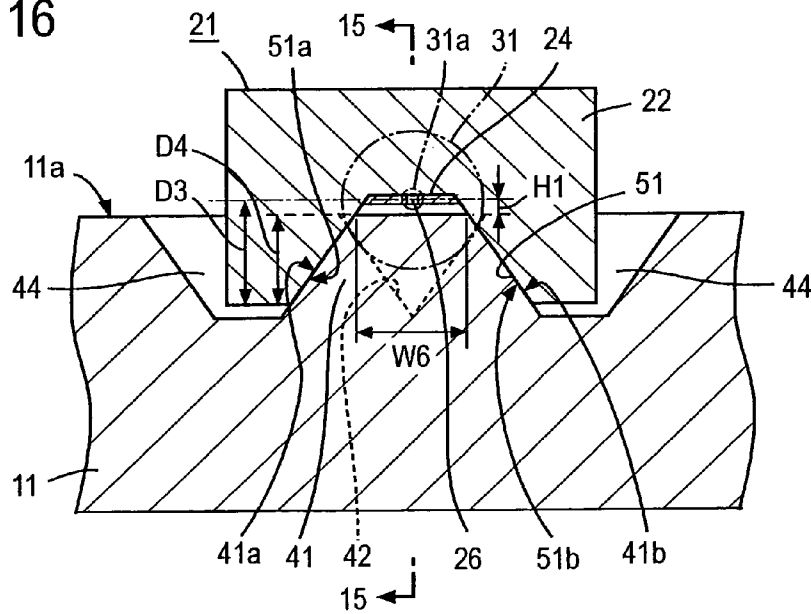

FIG. 17

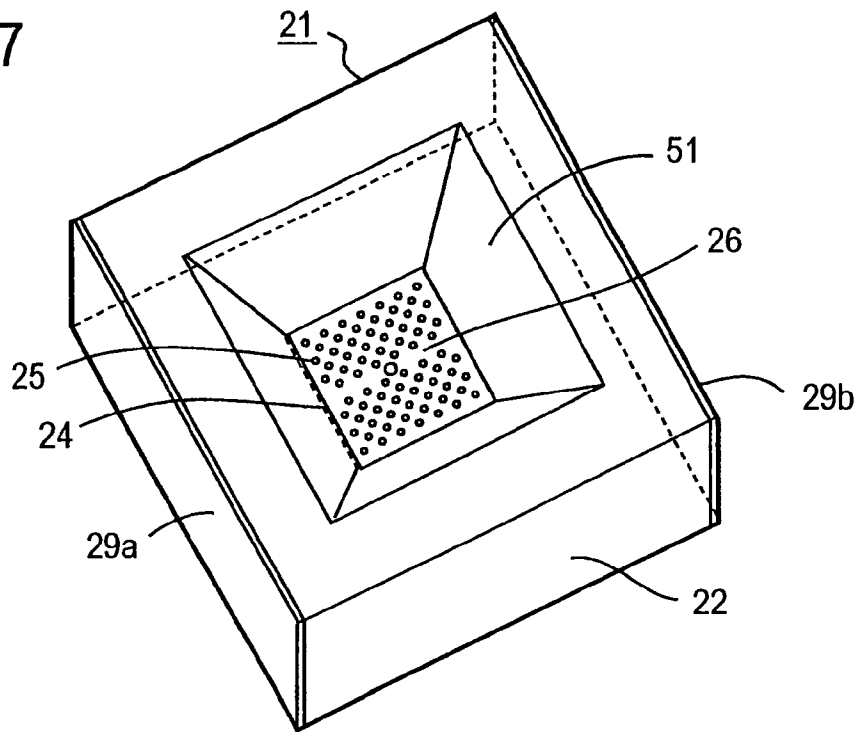

FIG. 18

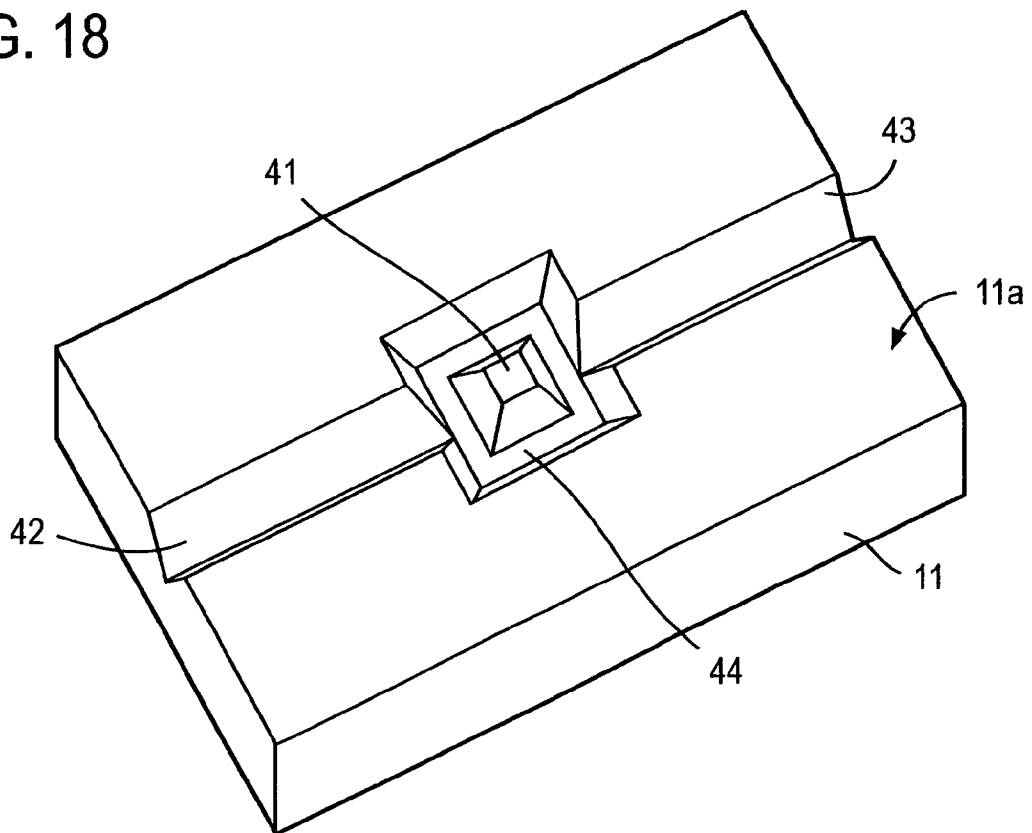

FIG. 19

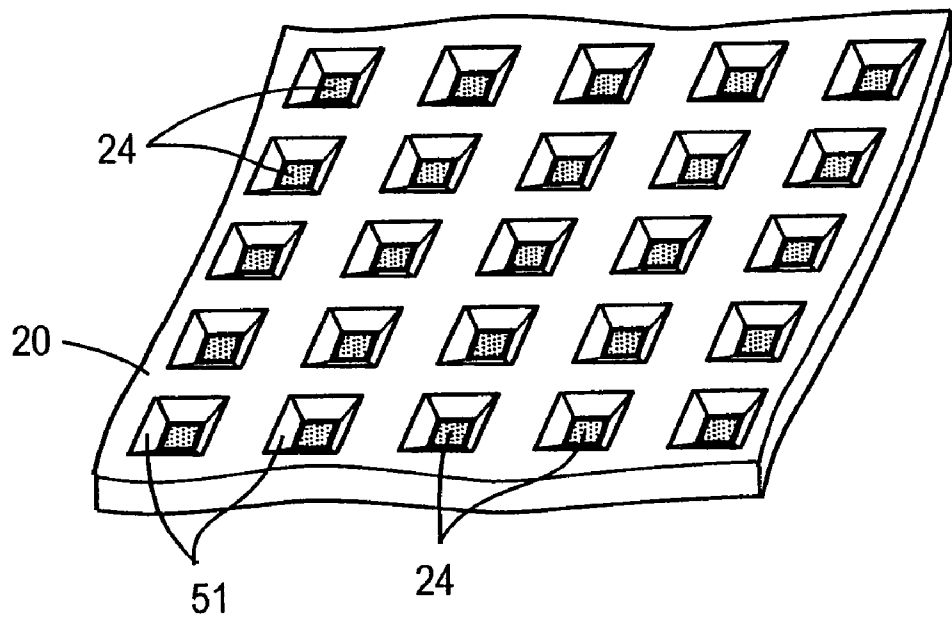



FIG. 22

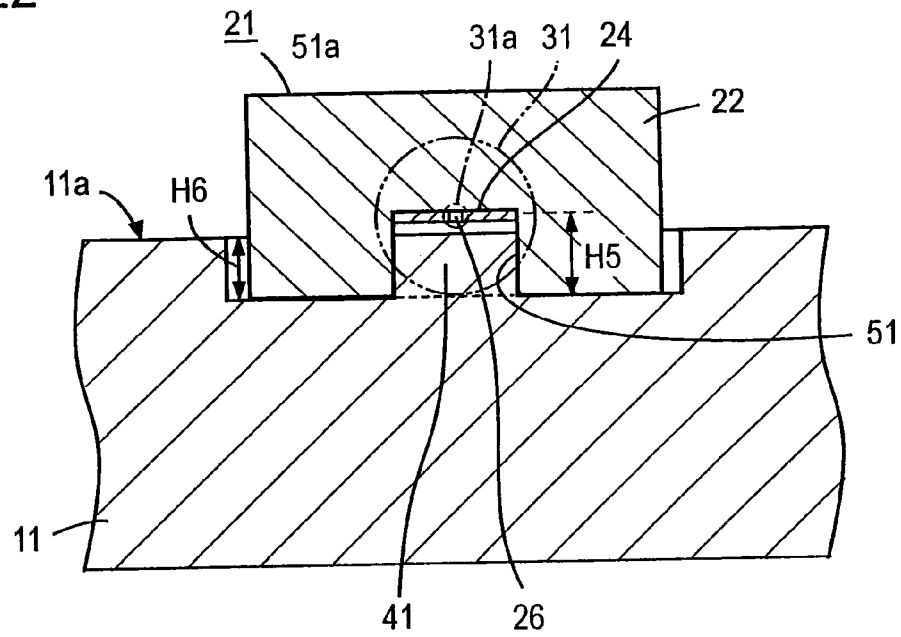
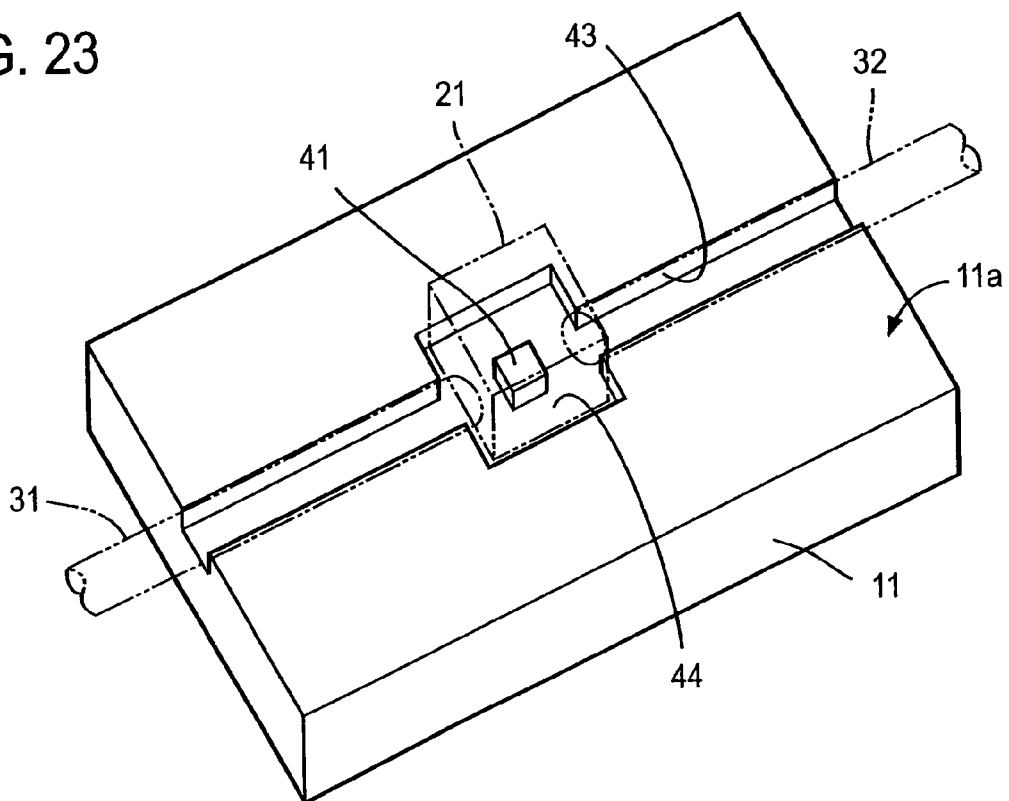

FIG. 23



## OPTICAL ELEMENT ASSEMBLY AND METHOD OF MAKING THE SAME

This Application is a division of Application, with a foreign priority number and filing date.

This is a Division of Application Ser. No. 10/806,579 filed on Mar. 22, 2004 now U.S. Pat. No. 7,110,630. The disclosure of the prior application is hereby incorporated by reference herein in its entirety.

### CROSS-REFERENCE TO RELATED APPLICATION

This application claims priority under 35 USC 119 from Japanese patent document, No. 2003-087895, the disclosure of which is incorporated by reference herein.

### BACKGROUND OF THE INVENTION

The present invention relates to an optical element assembly for use, for example, in the fields of optical communications, which permits highly accurate positioning of a microminiature optical element, such as a photonic crystal optical element, and an optical part, such as an optical fiber, with respect to each other. The invention also pertains to a method for the manufacture of such an optical element assembly.

In the fields of optical communications, a lot of attention has recently been given to artificial crystal materials (photonic crystals) whose refractive index changes with a period on the order of light wavelength. With the use of such photonic crystals, it is expected that advanced light-controlled functional elements which were impossible to realize in the past, such as a low-loss macrobend waveguide, a low-threshold laser and a wavelength division multiplexing element, can be fabricated in sizes of 100  $\mu\text{m}$   $\times$  100  $\mu\text{m}$  or smaller. With rapid progress in microfabrication technology, there have recently been made reports on prototypes of ultraminiature optical elements constructed from three- and two-dimensional photonic crystals for operation in a wavelength band for optical communications.

Slab-type photonic crystal optical waveguides are typical representatives of optical elements using the two-dimensional photonic crystals. The slab-type photonic crystals roughly fall into those of a structure in which a thin-film layer of a high refractive index material is perforated with two-dimensionally periodic arrays of air holes and those of a structure in which a thin-film layer of a low refractive index material has formed therein a two-dimensionally periodic arrays of rods of a high refractive index material. In both of the photonic crystals a photonic band gap develops when particular periodicity conditions are satisfied. By introducing air holes or an area without rods, that is, crystal defects into the periodic structure, an optical waveguide is formed which permits the propagation therethrough of light; namely, a line defect of missing holes or rods is defined to form the optical waveguide. Accordingly, the two-dimensional photonic crystals are considered as promising for realizing low-loss, ultraminiature optical waveguides.

However, since light inlet and outlet ports of such a slab type photonic crystal optical waveguide are approximately 1  $\mu\text{m}$  or less in size (in thickness) that is smaller than the core diameter (about 4 to 10  $\mu\text{m}$  in single mode) of an optical fiber, high-precision positioning of the waveguide and the optical fiber is difficult to achieve—this constitutes an obstacle to high-efficiency input of light to the waveguide. In the case of the optical waveguide of the photonic crystal

having air holes periodically arranged in the high refractive index material layer, since light is launched into the layer from air, reflectivity on the plane of incidence is high, giving rise to a heavy coupling loss.

Particularly advantageously the optical elements using photonic crystals are ultraminiature as referred to above, but substantially no consideration has been paid to simple and effective methods for coupling the photonic crystals to optical parts which are absolutely necessary for using them as optical elements, such as an optical fiber for signal transmission, a microminiature lens and so forth, and a method for keeping the coupling loss down.

For high-precision optical coupling of an optical element and an optical fiber or similar optical part, there have widely been used methods using a V-grooved structure in a single crystal silicon substrate. A V-groove can easily be formed in single crystal silicon by what is called single crystal silicon anisotropic wet etching (hereinafter referred to simply as anisotropic etching) that makes use of an anisotropic etching characteristic of single crystal silicon based on its crystal orientation. A simple example of such a method is disclosed, for example, in Japanese Patent Application Kokai Publication Gazette No. 281360/97 (published Oct. 31, 1997, hereinafter referred to as document 1). According to this method, one end portion of an optical fiber is fixed in a V-groove of a single crystal silicon substrate and a semiconductor laser or similar optical element is directly mounted on the non-grooved substrate surface on the side opposite the optical element in alignment therewith.

Another method is proposed, for example, in Japanese Patent Application Kokai Publication Gazette No. 2002-14258 (published Jan. 18, 2002, hereinafter referred to as document 2).

With reference to FIG. 1, the proposed method will be described below in brief. A single crystal silicon wafer, which has its principal plane formed by a crystal plane (100) or (101), is subjected to photolithography and anisotropic etching in this order to form rows and columns of square concavities of the same size and each having the same shape as the outside shape of an inverted frustum of a pyramid, and the silicon wafer is diced crosswise centrally of each square concavity into a large number of optical element carriers 1. On the bottom of such an optical element carrier 1 there is formed a cross-shaped convexity 2 resulting from the formation of each square concavity by anisotropic etching. Each side surface of the cross-shaped convexity 2 is tapered by anisotropic etching with high precision, that is, the cross-shaped convexity becomes narrower toward its protruding end (toward the principal plane or the top surface of the wafer). An optical semiconductor element 3 is mounted on one side of the optical element carrier 1 (on the thick portion of the wafer).

A single crystal silicon platform 4 has formed in its top surface by anisotropic etching cross-shaped V-groove 5 and a smaller V-groove 6 in alignment with the horizontal V-groove. The V-grooves 5 and 6 are separated by a square-sectioned groove 7 that extends at right angles to but communicate with them. Incidentally, such platforms are also simultaneously produced in quantities using a single crystal silicon wafer in the same manner as in the case of the optical element carrier 1. The optical element carrier 1 is mounted on the platform 4 with the cross-shaped convexity 2 of the former fitted in the cross-shaped V-groove 5 of the latter, and an optical fiber 8 is positioned in the V-groove 6. The cross-shaped convexity 2 and the cross-shaped V-groove 5 are high in dimensional accuracy, and through utilization of their mechanical accuracy, the optical element

3

carrier **1** can be mounted on the platform **4** with high accuracy. This ensures satisfactory optical coupling between the optical semiconductor element **3** mounted on the carrier **1** and the core of the optical fiber **8** disposed in the V-groove **6**.

According to the method of document 1, however, the optical element is fixedly mounted to the V-grooved substrate as by flip chip bonding while visually identifying a marker attached to the substrate. In the method of document 2, too, the optical element **3** is similarly mounted on the optical element carrier **1**. Accordingly, the positioning accuracy is dependent on the accuracy of bonding and lower than in the case of engagement between a V-groove and concave-convex structures (convexity and groove) formed by anisotropic etching.

On the other hand, a solution to this problem is set forth, for example, in Japanese Patent Application Kokai Publication Gazette No. 313756/96 (published Nov. 29, 1996, hereinafter referred to as document 3). According to the proposed method, a V-groove is cut in one surface area of a single crystal silicon and an optical waveguide is formed in alignment with the V-groove by coating a film directly on the non-grooved surface area of the substrate, thereby achieving positioning with accuracy of microfabrication.

It is difficult to mount such a microminiature optical element as the photonic crystal element by the methods set forth in documents 1 and 2, and even if it could be mounted, it gives rise to the above-mentioned problem that the positioning accuracy depends on the bonding accuracy. In the case of forming such a microminiature optical element as the photonic crystal element directly on the V-grooved substrate, the microminiature optical element takes up so small an amount of the V-grooved substrate surface that the manufacturing costs inevitably rise. In other words, since this method cannot utilize the technique of simultaneously forming a large number of microminiature optical elements on a substrate or wafer and severing them into individual elements, it is impossible to reduce the manufacturing costs through mass-production, failing to take advantage of microminiature optical elements.

#### SUMMARY OF THE INVENTION

It is therefore an object of the present invention to provide an optical element assembly which allows easy and high-precision positioning between an optical part and a microminiature optical element having light entering and emitting end faces (light inlet and outlet ports) of a size as small as 10  $\mu\text{m}$  or less and which permits mass-production of such microminiature optical elements.

Another object of the present invention is to provide a method of making the above-mentioned optical element assembly

In the optical element assembly according to the present invention, an optical element chip, which has a convexity or concavity formed in one side of a chip body and an optical element formed on the protruding end face of the convexity or the bottom of the concavity, is mounted in an element mounting portion of a platform by fitting therein the convexity or concavity of the optical element chip. This fitting ensures proper positioning of the optical element with respect to an optical element chip mounting surface (hereinafter referred to as a mounting surface) of the platform. In the mounting surface of the platform there is formed a part receiving concavity in to closely receive an optical part in proper positional relation for optical coupling to the optical element.

4

According to the manufacturing method of the present invention, convexities or concavities are formed in rows and columns by lithography and etching in one surface of a wafer to a predetermined height or depth from the wafer surface, then an optical element is formed on the protruding end face of each convexity or on the bottom of each concavity, and the wafer is severed into individual optical element chips. In the mounting surface of the platform on which an optical part is to be mounted, an element mounting portion and a part receiving recess for receiving the optical element positioned therein are formed by lithography and etching, and the optical element is mounted on the platform by engaging its convexity or concavity with the element mounting portion.

Since the optical element assembly of the present invention has the above-mentioned configuration in which the optical element is positioned on the mounting surface of the platform and the optical element is automatically positioned by the part receiving concavity with respect to the mounting surface, optical coupling between the optical part and the optical element is established with high accuracy. That is, since the optical element is formed on the protruding end face of the convexity or on the bottom of the concavity of the optical element chip, it is possible to adopt techniques of simultaneously forming a large number of convexities or concavities in a wafer, then simultaneously forming optical elements on protruding end faces of the convexities or on the bottoms of the concavities and severing the wafer into optical element chips; thus, it is possible to mass-produce optical element chips of the same shape and dimensions with high accuracy, and the optical element chip can be positioned on the platform with high accuracy by engagement of its convexity or concavity with the element mounting portion. Accordingly, when the optical part is mounted in the part receiving recess, its optical coupling to the optical element can be achieved with high accuracy. In addition, the optical element can be fabricated at low cost.

#### BRIEF DESCRIPTION OF THE DRAWINGS

FIG. 1 is an exploded perspective view showing a conventional optical element assembly;

FIG. 2 is a perspective view illustrating an embodiment of the present invention which is provided with an optical element chip having a convexity;

FIG. 3 is an enlarged perspective view of the optical element chip in FIG. 2;

FIG. 4 is an enlarged sectional view of one portion of the FIG. 2 embodiment, taken along the line 4-4 in FIG. 5;

FIG. 5 is a sectional view taken along the line 5-5 in FIG. 4;

FIG. 6A is a sectional view of part of a wafer covered with a resist film;

FIG. 6B is a perspective view showing, by way of example, patterning of the resist film on the wafer;

FIG. 6C is an enlarged sectional view of part of the wafer having each square resist **41a** coated with a protective film **61**;

FIG. 6D is a perspective view showing part of the wafer having formed thereon convexities;

FIG. 6E is an enlarged sectional view of part of the wafer with a groove protecting resist layer formed thereon by patterning;

FIG. 6F is a perspective view showing part of the wafer having an optical element formed on each convexity;

FIG. 7 is a perspective view illustrating another example of the platform;

FIG. 8 is an enlarged perspective view of part of an embodiment using the FIG. 7 platform, taken along the line 8-8 in FIG. 9;

FIG. 9 is a sectional view taken along the line 9-9 in FIG. 8;

FIG. 10 is an enlarged sectional view illustrating an embodiment using an ultraminiature lens as an optical part;

FIG. 11 is a perspective view of a platform used in Fig. the 10 embodiment;

FIG. 12 is a plan view illustrating an embodiment using an optical element of an optical waveguide;

FIG. 13 is a sectional view of an embodiment using a surface emitting light emitting element as an optical element, taken along the line 13-13 in FIG. 14;

FIG. 14 is a left side view of the FIG. 13 embodiment;

FIG. 15 is a sectional view of another embodiment using an optical element chip having a concavity, taken along the line 15-15 in FIG. 16;

FIG. 16 is a sectional view taken along the line 16-16 in FIG. 15;

FIG. 17 is a perspective view of the optical element chip in the FIG. 15 embodiment;

FIG. 18 is a perspective view of a platform used in the FIG. 15 embodiment;

FIG. 19 is a perspective view showing one part of the wafer on which there are formed a number of optical element chips shown in FIG. 17;

FIG. 20 is a sectional view taken along the line 20-20 in FIG. 21;

FIG. 21 is a sectional view taken along the line 21-21 in FIG. 20;

FIG. 22 is a sectional view, corresponding to FIG. 16, of another embodiment using an optical element chip having an optical element formed in a concavity; and

FIG. 23 is a perspective view showing an example of a platform used in FIG. 22.

#### DETAILED DESCRIPTION OF THE PREFERRED EMBODIMENTS

A description will be given first of an embodiment that uses an optical element chip provided with a protrusion or convexity.

##### Embodiment 1

This embodiment uses, as an optical element, a wavelength filter formed of a photonic crystal. As depicted in FIG. 2, an optical element chip 21 is positioned with respect to the mounting surface 11a and mounted on an element mounting portion 12a formed in one surface, i.e. in amounting surface of a platform 11. The optical element chip 21 may be adhesively bonded to the platform 11. In this embodiment the platform 11 has in its mounting surface 11a a V-groove 12 extending from the one to the other end thereof, and the intermediate portion of the V-groove 12 is used as the element mounting portion 12a. The V-groove portions 12 at both sides of the element mounting portion 12a form part receiving recesses 12b and 12c; in this example, optical fibers 31 and 32 as optical parts are inserted in the part receiving recesses 12b and 12c, then positioned with respect to the mounting surface 11a, and fixed to the platform 11. The optical fibers 31 and 32 are, for example, adhesively bonded to the platform 11, but this bonding may be done by individual users.

As shown in FIG. 3, the optical element chip 21 in this embodiment is composed of a square plate-like chip body

22, a convexity 23 protrusively provided on one side of the chip body 22, and an optical element 24 formed on the end face of the convexity 23. In this embodiment the optical element 24 is a wavelength filter constructed from the photonic crystal. That is, a high refractive index material layer is patterned with a two-dimensionally periodic arrays of holes 25, within which a line defect of missing holes is defined, where one hole of a different diameter is made to form a wavelength selective optical waveguide 26 that transmits therethrough light of a particular wavelength. In this embodiment the convexity 23 has the outside shape of a frustum of pyramid, that is, the bottom and protruding end face of the convexity 23 are similar squares, and four side surfaces of the convexity 23 are sloped.

As depicted in FIGS. 4 and 5, the optical element chip 21 is mounted on the platform 11 with the convexity 23 of the former fitted in the element mounting portion 12a of the latter to position the optical element 24 with respect to the mounting surface 11a. In FIGS. 4 and 5 the thickness of the platform 11 under the V-groove 12 is shown scaled-down. This applies to the corresponding drawings mentioned hereinafter.

The angle between both wall surfaces 12a<sub>1</sub> and 12a<sub>2</sub> of the V-groove of the element mounting portion 12a is equal to the angle between a pair of opposed side surfaces 23a and 23b of the convexity 23. Accordingly, when the spacing between the wall surfaces 12a<sub>1</sub> and 12a<sub>2</sub> coincides with the spacing between marginal edges of the side surfaces 23a and 23b at both sides of the optical element 24, the wall surfaces 12a<sub>1</sub>, 12a<sub>2</sub> and the side surfaces 23a, 23b make surface-to-surface contact with each other as shown in FIG. 5 and the convexity 23 inserted in the element mounting portion 12a is fixedly engaged therewith. With the convexity 23 fitted in the element mounting portion 12a, the depth D1 of the optical element 24 from the mounting surface 11a, that is, the position of the optical element 24 with respect to the mounting surface 11a in a direction perpendicular thereto is determined. The position of the optical element 24 in a plane parallel to the mounting surface 11a in a direction perpendicular to the direction of extension of the V-groove 12 is determined so that the center line between the side surfaces 23a and 23b of the optical element 24 lies midway between the wall surfaces 12a<sub>1</sub> and 12a<sub>2</sub> of the element mounting portion 12a.

The optical element 24 is held in parallel to the mounting surface 11a. That is, by fitting the convexity 23 in the element mounting portion 12a, the optical element 24 is automatically positioned with respect to the mounting surface 11a.

When the optical fibers 31 and 32 are inserted in the part receiving recesses 12b and 12c, cores 31a and 32a of the optical fibers 31 and 32 are located midway between both wall surfaces of the parts receiving grooves 12b and 12c, and their depth D2 (distance from the mounting surface 11a) is also determined. That is, when inserted and mounted in the part receiving recesses 12b and 12c, the optical fibers 31 and 32 are automatically positioned with respect to the mounting surface 11a.

Since the diameters of the optical fibers 31 and 32, which are commercially available, are known, and since the side surfaces 23a and 23b of the convexity 23 are sloped in conformity to the inclined wall surfaces of the V-groove 12 so that when the optical fibers 31 and 32 are mounted in the part receiving recesses 12b and 12c, the width W1 of each of the part receiving recesses 12b and 12c at the depth D2 of the optical fiber cores 31a and 32a from the mounting surface 11a coincides with the width W2 of the protruding

end face of the convexity **23** to place the fiber cores **31a** and **32a** in alignment with the optical element **23**, automatically establishing optical coupling between the optical element **23** and the optical fibers **31** and **32** with high accuracy.

According to this embodiment, when the optical element chip **21** is mounted on the platform **11** by fitting the convexity **23** of the former into the element mounting portion **12a** of the latter, the position of the optical element **24** in the direction perpendicular to the mounting surface **11a** and in one direction parallel thereto is determined to hold the optical element **24** in parallel to the mounting surface **11a**, and when the optical fibers **31** and **32** are mounted in the part receiving recesses **13b** and **13c**, they are each located at the same position as that of the optical element **24** in the above-mentioned direction perpendicular to the mounting surface **11a** and in the said one direction parallel thereto, and consequently the optical fibers **31** and **32** optically couple to the optical element **24** with high accuracy.

With the structure of this embodiment, light propagated through the optical fiber **31** enters the photonic crystal optical element **24**, and only an optical component of a wavelength determined by the constitution of the optical element **24** is transmitted therethrough and launched into the optical fiber **32** for propagation therethrough.

#### Embodiment of Manufacturing Method

A description will be given of an embodiment of a method for making the optical element assembly of Embodiment 1 described above.

As depicted in FIG. 6A, a single crystal silicon wafer **20**, for instance, is coated over the entire area of its crystal plane (100) with a resist layer **41**, which is subjected to patterning by ultraviolet ray or electron beam lithography and developed. At this time, patterning for forming the convexities **23** and patterning for forming air holes **25** and wavelength selective optical waveguides **26** of photonic crystal elements in this example are conducted at the same time. That is, as shown in FIG. 6B, many square resists **41a** are left unremoved in rows and columns, and each resist **41a** has many air holes **25** and one air hole of a different diameter as depicted in FIG. 3. In FIG. 6B, the air holes are all shown as dots for the sake of convenience.

A protective film is formed all over the wafer surface including the square resists **41a**, and the film is patterned by photolithography to form a protective film **61** over each square resist **41a** as shown in FIG. 6C.

Next, the wafer **20** is subjected to etching by KOH liquid, using the protective films **61** and the square resists **41a** as etching masks. Due to anisotropy by the crystal orientation of single crystal silicon, grooves **62** are formed to define frustum-shaped convexities **23** in rows and columns as depicted in FIG. 6D. After removal of the protective film **61** resist is coated all over top surface of the wafer **20** and patterned by photolithography to form resist portions **63** protecting the grooves **62** and expose the square resists **41a** on the protruding end faces of the convexities where patterns of photonic crystal are formed.

The photonic crystal optical elements **24** are formed on the top faces of the convexities **23** by inductive coupling plasma etching or similar dry etching through the square resists **41a**. This is followed by the removal of the square resists **41a** and the protective resist portions **63** to provide a structure that has the photonic crystal optical element (wavelength selective waveguide element) **24** formed directly on the top of each convexity **23**. The relative positioning of the

mask and the wafer for patterning the protective films **61** and the protective resist portions **63** is carried out using markers positioned at the same time as the convexities **23** and the photonic crystal optical elements were subjected to patterning, for instance.

The machining of photonic crystal is not limited specifically to the above-mentioned lithography but femto-second laser machining can also be used. In this instance, positioned markers are formed together with the convexities **23** through utilization of photolithography masks for the convexities **23**, then the marker areas are subjected to etching to form through holes in the wafer, the light intensity of the femto-second laser passing through the through holes is monitored to detect the position of the laser beam with respect to the wafer **20**, and laser machining is performed accordingly.

The wafer **20** having photonic crystal optical elements **24** formed on the top surfaces of the respective convexities **23** is diced into plural optical elements chips **21** such as shown in FIG. 5.

The platform **11** is also mass-produced by forming many V-grooves **12** in parallel, for example, in a single crystal silicon wafer by anisotropic etching and dicing the wafer into individual platforms **11** as depicted in FIG. 2.

As described above, the width of a resist mask for forming each V-groove **12** can be used to accurately define the depth **D2** from the mounting surface **11a** where the cores **31a** and **32a** of the optical fibers **31** and **32** are located. Further, the spacing **W1** between the opposed wall surfaces of the V-groove **12** at the depth **D2** is also defined. The width of the resist mask, which determines the formation of the side surfaces **23a** and **23b** during the formation of the convexity **23** is chosen equal to the width **W2** of the protruding end face of the convexity **23** between the marginal edges of the side surfaces **23a** and **23b**; this can also be determined with high accuracy. As the result of this, the angle between the both wall surfaces of the V-groove **12** and the angle formed by the side surfaces **232a** and **23b** of the convexity **23** becomes equal.

Since the reference for determining the spacing **W2** between marginal edges of the side surfaces **23a** and **23b** of the convexity **23**, which determines the position where to mount the optical element **24** on the element mounting portion **12a**, that is, position the optical element **24** with respect to the mounting surface **11a**, and the reference for determining the position of the optical element **24** with respect to the optical element chip **21**, in this example, the positions of the light inlet and outlet ports of the wavelength selective optical waveguide of the optical element **24**, in particular, are the same as the reference point of the mask that is used for lithography for fabricating the optical element chip **21**, the optical element **24** is positioned with respect to the platform **11** with high accuracy when the optical element chip **21** is mounted on the platform **11**. The positions and shapes of the element mounting portion **12a** and the part receiving recesses **12b** and **12c** in the platform **11** with respect to the mounting surface **11a** are also highly accurate because they are formed with reference to the same mask during the formation by the lithography. Accordingly, the light inlet and outlet ports of the wavelength selective optical waveguide, which is the optical element **24** in this example, are aligned with the cores **31a** and **32a** of the optical fibers **31** and **32** with high accuracy, establishing optical coupling between the optical element **24** and the optical fiber cores **31a** and **32a** with a very high degree of accuracy.

By anisotropic etching of the single crystal silicon wafer as referred to previously, it is possible to form the side

surfaces that are flat at the atomic phase level and high in dimensional accuracy. Accordingly, positioning for optical coupling between the light inlet and outlet ports of the optical element **24** and the cores **31a** and **32a** of the optical fibers **31** and **32** can be achieved with high accuracy on the order of 1  $\mu\text{m}$  or less; hence, the optical fiber cores **31a** and **32a** can be positioned with respect to a slab type photonic crystal optical waveguide even if its light inlet and output ports are on the order of 1  $\mu\text{m}$  or less in size (thickness). In addition, the optical element chip **21** can be mass-produced, and each optical element chip **21** can easily be mounted on the platform **11** by fitting the former into the latter.

In the case where the optical element **24** is a two-dimensional photonic crystal optical element having a high refractive index material layer perforated with the air holes **25** as depicted in FIG. 3, incidence and emittance of light take place between air of a low refractive index and the optical element **24** of a high refractive index, and hence there is a fear of causing a serious reflection loss. This can be avoided by forming antireflective films on the light inlet and outlet ports of the photonic crystal optical element **24**. In FIG. 3, antireflective films **29a** and **29b** are formed on side surfaces of the convexity **23** perpendicular to the wavelength selective optical waveguide **26**. The antireflective films **29a** and **29b** may be formed, for example, simultaneously with each convexity **23** prior to severing the wafer **20** after the formation of the convexities **23** in the course of manufacturing the optical element chips described above with reference to FIG. 6.

#### Embodiment 2

This embodiment is intended to increase the number of optical element chips **21** obtainable from one wafer **20** (FIG. 6) by making the width of the V-groove of the element mounting portion **12a** narrower than the part receiving recesses **12b** and **12c** and reducing the length of protrusion of the convexity **23**. FIG. 7 shows an example of the platform **11** in this embodiment. The element mounting portion **12a** and the part receiving recesses **12b** and **12c** formed by V-grooves are axially aligned with each other, looking in the direction perpendicular to the mounting surface **11a**, but the groove width **W3** of the element mounting portion **12a** is smaller than the groove width **W4** of each of the part receiving recesses **12b** and **12c**. In the case of forming these V-grooves by anisotropic etching, since both ends of the element mounting portion **12a** protrude obliquely downwardly into the recesses **12b** and **12c**, the optical fibers **31** and **32** cannot be disposed close to the optical element **24** accordingly. In this example, narrow grooves **13a** and **13b** are cut in the platform **11** at right angles to each V-groove at the boundaries between the element mounting portion **12a** and the part receiving recesses **13a**, **13b**, making respective faces of the recesses **12b** and **12c** perpendicular to the mounting surface **11a**.

FIGS. 8 and 9 are sectional views of this embodiment respectively corresponding to FIGS. 4 and 5. As can be seen from FIG. 9, the distance **D1** from the optical element **24** to the mounting surface **11a** is equal to the distance **D2** from the optical fiber cores **31a** and **32a** to the mounting surface **11a**, but the spacing **W2** between the marginal edges of the side surfaces **23a** and **23b**, which determines the depth of insertion of the convexity **23** into the element mounting portion **12a**, is determined by the narrow groove of the element mounting portion **12a**, and the depth of insertion **D1** of the convexity **23** is the same as in Embodiment 1, but the spacing **W2** is narrower than in the case of Embodiment 1.

Accordingly, the area of the protruding end face of the convexity **23** can be made smaller than in the case of Embodiment 1.

#### Embodiment 3

This embodiment uses a microminiature lens as an optical part. FIG. 10 shows in section the structure of this embodiment, corresponding to the FIG. 4 sectional view of Embodiment 1, and FIG. 11 depicts an example of the platform **11** for use in this embodiment. In the mounting surface **11a** of the platform **11** there are formed a square part receiving concavity **14** and a V-groove **15** extending at right angles to one side thereof and opening into the concavity **14**. One part **15a** of the V-groove **15** is used as the element mounting portion. In this example, the V-groove **15** is formed as its extension **15b** in the platform surface also on the side thereof opposite the element mounting portion **15a**; that is, the V-groove **15** opens at both ends to the outside of the platform **11**. The part receiving concavity **14** and the V-groove **15** can be formed simultaneously by, for example, anisotropic etching.

As shown in FIG. 10, a microminiature spherical lens **33** is disposed in and positioned by the part receiving concavity **14**, by which the optical axis **34** of the spherical lens **33** is positioned with respect to the mounting surface **11a**. That is, four wall faces **14a** to **14d** of the part receiving concavity **14** contact the spherical lens **33** to arrest its further downward insertion into the concavity **14**, by which the distance **D3** of the optical axis **34** from the mounting surface **11a**, that is, the position of the optical axis **34** in the direction perpendicular to the mounting surface **11a** is determined and, at the same time, the position of the optical axis **34** in the plane perpendicular to the mounting surface **11a** and containing the center line between the wall surfaces **14a** and **14c** is determined. In this way, the spherical lens **33** is automatically positioned by the part receiving concavity **14** with respect to the mounting surface **11a**. The spherical lens **33** is fixed to the platform by use of an adhesive, for instance.

The optical element chip **21** has the same construction as, for example, in Embodiment 1. Accordingly, when the optical element chip **21** is mounted with its convexity **23** fitted in the element mounting portion **15a** of the V-groove **15**, the pair of opposed side surfaces (corresponding to those **23a** and **23b** in Embodiment 1) of the optical element chip **21** make surface-to-surface contact with both wall surfaces of the V-groove **15**, and the insertion depth **D1** of the convexity **23** is determined by the spacing (corresponding to **W2** in Embodiment 1) between the marginal edges of the above-mentioned opposed side surfaces of the optical element **24**, by which the optical element **24** is positioned with respect to the mounting surface **11a** as is the case with Embodiment 1. Accordingly, the optical element **24** is positioned with respect to the mounting surface **11a** by the same scheme as in Embodiment 1 so that the depth **D1** of the optical element **24** and the depth **D3** of the optical axis are equal to each other and that a plane containing the center axis between the wall surfaces **14a** and **14c** of the concavity **14** and a plane just midway between both wall surfaces of the V-groove **15** coincide in a plane perpendicular to the mounting surface **11a**. This can easily be accomplished by forming the concavity **14** and the V-groove **15** in the platform **11**, for example, by anisotropic etching.

The focal point of the spherical lens **33** may preferably be in alignment with the light inlet/outlet port of the optical element **24** facing the lens **33**. As shown in FIG. 11, at least two markers **16a** and **16b** are symmetrically formed at both

## 11

sides of the V-groove 15 on the mounting surface 11a in the vicinity of the element mounting portion 15a so that the light inlet/outlet port of the optical element 24 is located at a position spaced the focal length D4 of the spherical lens 33 away from a plane just midway between the wall surfaces 14b and 14d of the part receiving concavity 14. The markers 16a and 16b may be formed as metal films by photolithography simultaneously with the formation of the part receiving concavity 14 and the V-groove 15. To mount the optical element chip 21 on the mounting portion 15a with respect to the markers 16a and 16b, the convexity 23 needs only to be fitted in the element mounting portion 15a with both corners of the chip body 22 on the side of the convexity 23 positioned with respect to the markers 16a and 16b, for example, under a microscope in the same manner as in the case of using flip chip bonding techniques. The optical element chip 21 and the platform 11 are fixed, for example, by an adhesive.

In this optical element assembly, the optical axis 34 of the spherical lens 33 is held in parallel to the optical element 24, and the focal point of the spherical lens 33 lies on the light inlet/outlet port of the optical element 24 facing the lens 33. This ensures accurate optical coupling between the spherical lens 33 and the optical element 24. Light incident on the spherical lens 33 on the side opposite the optical element 24 is focused by the spherical lens 33 and launched into the optical element 24, and in this example only a particular wavelength component of the incident light passes through the optical element 24 that functions as a wavelength filter. It will easily be understood that this embodiment also produces that same operation/working effect as is obtainable with Embodiment 1.

## Embodiment 4

This embodiment uses, as the optical element 24, an element having an optical waveguide formed of the photonic crystal. FIG. 12 is a plan view of the principal part of such an optical element. In FIG. 12 the optical element chip 21 is shown as being inverted on the plane of the paper, that is, on the platform surface, as indicated by the chain double-dashed lines. In the mounting surface 11a of the platform 11 V-grooves 12 and 17 of the same shape and size are formed crosswise at right angles to each other, and their intersecting portion is used as an element mounting portion 18, by which the V-grooves 12 and 17 are each separated into two, each of which is used as a part receiving recess 12b (17b). That is, the part receiving recesses 12b and 17b extend at right angles to each other with the element mounting portion 18 located at the corner between them.

The optical element chip 24 is about the same as that used in Embodiment 1 but differs therefrom in that a 90° bend optical waveguide 27 is formed as the optical element 24. The optical element 24 is a photonic crystal slab of a high refractive index material which is perforated with two-dimensionally periodic arrays of air holes but has a 90° angle bending area with no air holes by which the optical waveguide 27 is defined.

The optical element 24 having such an optical waveguide 27 is positioned with respect to the mounting surface 11a in the same manner as described previously with reference to Embodiment 1. By the engagement of the pair of opposed side surfaces of the convexity 23 of the optical element chip 21 with both wall surfaces of the V-groove extending from the part receiving recess 12b of the element mounting portion 18, the position of the optical element 24 is determined in the direction of depth (in the vertical direction)

## 12

from the mounting surface 11a and in the direction perpendicular to the direction of extension of the V-groove and parallel to the mounting surface 11a. With the engagement of the other pair of opposed side surfaces of the convexity 23 of the optical element chip 21 with both wall surfaces of the V-groove extending from the part receiving recess 17a of the element mounting portion 18, the position of the optical element 24 is determined in the direction of depth from the mounting surface 11a and in the direction perpendicular to the direction of extension of the V-groove 17 and parallel to the mounting surface 11a. In this instance, the above-mentioned two positions in the direction of depth from the mounting surface 11a are the same. That is, the protruding end face of the convexity 23 is square in plan configuration.

As in the case of Embodiment 1, one end portion of the optical fiber 31 is positioned and mounted in the part receiving recess 12b and one end portion of the optical fiber 32 is similarly positioned and mounted in the part receiving recess 17a. Accordingly, the cross-section of this embodiment perpendicular to the mounting surface 11a containing the optical fiber core 31a is substantially the same as the cross section in FIG. 4 except the optical fiber 32, the cross section perpendicular to the mounting surface 1a containing the optical fiber core 32a is substantially the same as the cross section in FIG. 4 except the optical fiber 31, and the cross section perpendicular to the optical fiber core 31a and the mounting surface 11a at the turn of the optical waveguide 27 is substantially the same as the cross section shown in FIG. 5. In this case, the optical waveguide 27 takes the place of the wavelength selective optical waveguide 26 in FIG. 5.

Because of such a configuration as described above, the optical element assembly of this embodiment has the same advantages as are obtainable with the Embodiment 1. That is, the optical waveguide 27 of the optical element 24 and the optical fiber core 31a are in accurate alignment with each other, and the optical waveguide 27 and the optical fiber core 32a are also in accurate alignment with each other—this ensures accurate optical coupling between the optical fiber cores 31a and 32a through the optical waveguide 27 of the optical element 24.

## Embodiment 5

The optical element 24 is not limited specifically to the photonic crystal waveguide but may also be a vertical-cavity surface-emitting laser such as described below. The vertical-cavity surface-emitting laser is set forth, for example, in a Japanese journal, "Laser Kenkyuu," Vol. 29, No. 12(December 2001), pp. 773-778. The vertical-cavity surface-emitting laser has, in some cases, light inlet and outlet ports of a size of about 3 μm, and it is desirable that this laser and optical parts be positioned with respect to each other with high accuracy.

FIGS. 13 and 14 illustrate the structure of this embodiment, FIG. 13 being a schematic diagram of the assembly structure partly in section along the line 13-13 in FIG. 14 and FIG. 14 being a left side view of the FIG. 13 structure. In the mounting surface 11a of the platform 11, as in the case of FIG. 2, there is formed the V-groove 12, one portion of which is used as the element mounting portion 12a, and the V-groove 12 at the left-hand side of the element mounting portion 12a in FIG. 13 is used as the part receiving recess 12b. The optical element chip 21 is about the same as that in Embodiment 1 but differs therefrom in that the vertical-cavity surface-emitting laser 28 is formed as the optical element 24 on the protruding end face of the convexity 23.

13

The optical element chip **21** is obtained by: forming the convexities **23** in quantities in row and columns, for example, on a single crystal GaAs wafer by means of photolithography and anisotropic etching in the same manner as described previously with respect to FIG. 6; then forming a compound semiconductor laser, as the vertical-cavity surface-emitting laser, on the protruding end face of each convexity **23** by patterning by photolithography, formation of a thin film by crystal growth and by selective removal of the thin film by etching; and cutting the wafer into individual optical element chips **21** each bearing the vertical-cavity surface-emitting laser **28**.

The optical element chip **21** is mounted in place in the element mounting portion **12a** by fitting the convexity **23** in the V-groove. That is, as in the case of Embodiment 1, the laser **28** is automatically positioned with respect to the mounting surface **11a** at the depth that is determined by the width **W1** of the protruding end face of the convexity **23** defined by the marginal edges of its side surfaces **23a** and **23b**. Though not shown in FIGS. 23 and 14, the optical element chip **21** is mounted on the mounting surface **11a** at a predetermined position defined by the markers **16a** and **16b** (see FIG. 11) in the lengthwise direction of the V-groove **12** as described previously with reference to FIG. 11, for instance.

On end portion of the optical fiber **31** is positioned in the part receiving recess **12b** in the same manner as in Embodiment 1. In the V-groove **12** opposite the part receiving recess **12b** a mirror **35** is mounted on the platform **11**. The mirror **35** is produced by cutting aslant one end of a cylinder as of metal, ceramics or glass and sufficiently accurate in diameter and coating a metal film all over the cut end face to form a mirror surface **35a**. The mirror surface **35a** is held opposite the light emitting surface of the vertical-cavity surface-emitting laser **28** and the core **31a** of the optical fiber **31** so that light emitted from the vertical-cavity surface-emitting laser **28** is reflected by the mirror surface **3a** for incidence on the core **31a**.

That is, because of its cylindrical configuration, the mirror **35** is positioned by the V-groove **12** at the predetermined depth from the mounting surface **11a**. In this case, the mirror **35** needs only to be positioned so that any area of the mirror surface lies at the depth **D2** of the core **31a** of the optical fiber **31**; the diameter of the mirror **35** is chosen to meet such a requirement. The mirror **35** is positioned under visual observations to bring the mirror surface into opposing relation to the vertical-cavity surface-emitting laser **28**, then the vertical-cavity surface-emitting laser **28** is caused to emit light, the intensity of light emitted from the optical fiber **31** is monitored, then the mirror **35** is turned about its axis to maximize the emitted light intensity, then fine adjustments are made to the distance between the mirror **35** and the optical fiber **31**, and the mirror **35** is fixed to the platform **11** using an adhesive, for instance. The position of the mirror **35** can be adjusted relatively easily.

In this embodiment, the vertical-cavity surface-emitting laser **28** is formed on the protruding end face of the convexity **23**, and the protruding end face and the convexity **23** are defined by an etching mask, that is, formed based on the same reference point, and the vertical-cavity surface-emitting laser **28** is positioned at the center of the protruding end face of the convexity **23** with high accuracy. Since the vertical-cavity surface-emitting laser **28** is positioned by the side surfaces **23a** and **23b** of the convexity **23** and the opposed wall surfaces of the V-groove **12**, the laser **28** bisects the V-groove **12** and is located in the plane perpendicular to the mounting surface **11a** with high accuracy.

14

Accordingly, the vertical-cavity surface-emitting laser **28** and the optical fiber **31** are optical coupled with high accuracy.

In Embodiments 1 through 4, the optical fiber may be replaced with a microminiature lens for optical coupling to the optical element **24** as in Embodiment 5.

## Embodiment 6

In this embodiment, the optical element chip has an optical element formed on the bottom of a concavity formed in one side of the chip body. That is, in the present invention, the optical element chip has a convexity or concavity formed in one side of the chip body and an optical element formed on the protruding end face of the convexity or on the bottom of the concavity. A description will be given of an embodiment that uses the optical element chip having an optical element formed on the bottom of the concavity.

FIGS. 15 and 16 are sectional views of this embodiment which correspond to FIGS. 4 and 5, respectively. The platform **11** has on its mounting surface **11a** a convex element mounting portion **41** for engagement with the optical element chip **21**. That is, a concavity **51** is formed in one side of the chip body **22** of the optical element chip **21** and the optical element is formed on the bottom of the concavity **51**. By engagement between the concavity **51** and the element mounting portion **42**, the optical element chip **21** is mounted on the platform **11** and the optical element **24** is automatically positioned with respect to the mounting surface **11a**. The optical element chip **21** is made of a light transmitting material for use in this optical element assembly.

At both sides of the element mounting portion **41** of the mounting surface **11** part receiving recesses **42** and **43** are extended in opposite directions, which receive end portions of the optical fibers **31** and **32**, respectively. The cores **31a** and **32a** of the optical fibers **31** and **32** are automatically positioned by the grooves **42** and **43** with respect to the mounting surface **11a**.

FIG. 17 shows an example of the optical element chip **21** for use in this embodiment. In one side of the chip body **22** there is formed the concavity **51** whose inside shape is an inverted pyramidal frustum and on the bottom of which is formed a photonic crystal optical element **24** having two-dimensional periodic arrays of air holes in the high refractive index material layer and the wavelength selective optical waveguide **26** as depicted, for example, in FIG. 3. Such optical element chips **21** can be mass-produced by the same method as referred to previously with reference to FIG. 6. In this instance, as depicted in FIG. 19, many concavities are formed in the single crystal silicon wafer by anisotropic etching through square masks, and the photonic crystal element **24** is formed on the bottom of each concavity **51**. The cross section of each concavity **51** perpendicular to the wafer **20** is an inverted pyramidal frustum. The wafer **20** is cut into individual optical elements **21** each having the optical element **24**.

FIG. 19 illustrates an example of the platform **11** for use in this embodiment. In the central portion of the mounting surface **11a** there are formed a square-frame-like groove **44** of a cross section just like an inversion of a pyramidal frustum and a pyramidal frustoidal convexity or protrusion surrounded by the groove **44**, that is, the element mounting portion **41** is formed. On the line bisecting the element mounting portion **41** there are formed in the platform **11** V-grooves, as the parts receiving grooves, that extend from both sides of the element mounting portion **41** and commu-

15

nicate with the square-frame-like groove 44. The platform 11 is formed of single crystal silicon, for instance, and the element mounting portion 41 and the part receiving recesses 42 and 43 can easily be formed by anisotropic etching.

As depicted in FIG. 16, opposed side surfaces 41a and 41b of the element mounting portion 41 and opposed wall surfaces 51a and 51b of the concavity 51 of the optical element chip 21 make surface-to-surface contact with each other at the place where the spacing between the opposed wall surfaces 51a and 51b is equal to the width W6 of the protruding end face of the element mounting portion 41 between the opposed pair of its side surfaces 41a and 41b. By this, the element mounting portion 41 and the concavity 51 are engaged with each other. Let H1 represent the height (distance) of the optical element 24 with respect to the mounting surface 11. The optical fibers 31 and 32 are positioned by the part receiving recesses 42 and 43. Let H2 represent the height (distance) of the optical fiber cores 31a and 32a with respect to the mounting surface 11a. The depth of the V-grooves 42 and 43, or the depth D3 of the concavity 51 is set such that the difference between the depth D3 of the concavity 51 and the depth D4 where the spacing the wall surfaces 51a and 51b becomes W6 is H1 and that H1 is equal to H2. The center lines of the part receiving recesses 42 and 43 are aligned with the center line between the side surfaces 41a and 41b of the element mounting portion 41.

With the above structure, light having propagated through the one optical fiber 31 enters the optical element 24, in particular, the wavelength selective optical waveguide 26, and a particular wavelength component passes through the optical element 24 and enters the other optical fiber 32.

Since the optical element 24 is formed on the bottom of the concavity 51, the reference point for the position of its formation is the same as the reference point for the position of forming the concavity 51, enabling the optical element 24 to be positioned with respect to the concavity 51 with high accuracy. When the optical element chip 21 is fitted in the element mounting portion 41, the optical element 24 is automatically positioned with respect to the mounting surface 11a with a very high degree of accuracy as in Embodiment 1. Similarly, when the optical fibers 31 and 32 are mounted in the part receiving recesses 42 and 43, the fiber cores 31a and 32a are automatically positioned with respect to the mounting surface 11a with high accuracy. Accordingly, the optical element 24 and the optical fibers 31 and 32 are optically coupled with high accuracy. It will readily be understood that this embodiment produces the same operation/working-effect as is obtainable with Embodiment 1. It is desirable to form anti-reflection films 29a and 29b on the outer side surfaces of the optical element chip 21 facing the optical fibers 31 and 32, respectively.

The optical element 24 that is formed on the bottom of the concavity 51 of the optical element chip 21 may be the photonic crystal optical waveguide element shown in FIG. 12, a photonic crystal laser, or the vertical-cavity surface-emitting laser of a compound semiconductor described previously with respect to Embodiment 5. According to the kind or type of the optical element 24 used, the structure of the element mounting portion 41 of the platform 11, that is, the structure and arrangement of the part receiving recesses for mounting optical parts such as optical fibers and micro-miniature lenses are modified accordingly.

#### MODIFICATIONS

The cross section of the optical element chip 21 perpendicular to the protruding end face of the convexity 23 need

16

not always be frustoidal but may also be square; that is, the convexity 23 may be a short-axis quadrangular prism. This will be described below with reference to FIGS. 20 and 21 in which the optical element 24 is a wavelength selective optical waveguide. FIGS. 20 and 21 correspond to FIGS. 4 and 5, respectively. Unlike in FIGS. 4 and 5, the convexity 23 of the optical element 24 is a short quadrangular prism; accordingly, the V-grooves each are replaced with a square-sectioned groove 45, the width W7 of its central portion is narrowed to form an element mounting portion 45a, and those portions of each groove 45 which extend outwardly of the central portion and have a width W8 wider than W7 are used as part receiving recesses 45b and 45c. The width W7 is chosen equal to the spacing W9 between the opposed side surfaces 23a and 23b of the convexity 23 so that the optical element chip 21 is mounted on the platform 11 with the convexity 23 fitted in the element mounting portion 45a. The length of protrusion H3 of the convexity 23 is set with reference to its protruding end face, and the chip body 22 is abut against the mounting surface 11a of the platform 11.

The optical fibers 31 and 32 are positioned in the part receiving recesses 45b and 45c, respectively. That is, peripheral surfaces of the optical fibers 31 and 32 make line-to-line contact with the bottoms of the part receiving recesses 45b and 45c and edges of the square grooves near the mounting surface 11a, respectively, by which the optical fibers are positioned with respect to the mounting surface 11a. In this case, the distance H of each of the fiber cores 31a and 32a to the mounting surface 11a is equal to the distance H3 between the optical element 24 and the mounting surface 11a, and the fiber cores 31a and 32a are disposed opposite the optical element 24, in particular, the light inlet and outlet ports of the wavelength selective optical waveguide 26.

The convexity 23 of each optical element chip 21 can be formed, for example, by dry etching during mass-production of optical element chips, and the part receiving recesses 45a, 45b and 45c can also be formed by dry etching in the platform 11.

The inside shape of the concavity 51 of the optical element chip 21 may be a quadrangular prism as shown in FIGS. 22 and 23, in which the optical element 24 is a wavelength selective optical waveguide. FIGS. 22 and 23 correspond to FIGS. 16 and 18, respectively. This example differs from Embodiment 6 in that the inside shape of the concavity 51 of the optical element chip 21 is a short quadrangular prism; accordingly, the convexity of the element mounting portion 41 is also a short quadrangular prism, and the chip body 22 is abut against the bottom of the groove 44. The part receiving recesses 42 and 43 are square in section, that is, both wall surfaces of each groove are perpendicular to the mounting surface 11a and the bottom of the groove is parallel to the mounting surface 11a. Four wall surfaces of the groove 44 are also perpendicular to the mounting surface 11a and the bottom of the groove 44 is also parallel to the mounting surface 11a. The peripheral surfaces of the optical fibers 31 and 32 make line-to-line contact with the bottoms of the part receiving recesses 42 and 43 and edges of their wall surfaces near the mounting surface 11a.

The depth H5 of the optical element 24 is set with reference to the bottom of the concavity 51, and the chip body 22 makes contact with the bottom of the frame-like groove 44 to determine the position of the optical element 24 with respect to the mounting surface 11a, and the depth H6 of the groove 44 is set with reference to the mounting surface 11a. The optical fibers 31 and 32 are positioned by the part receiving recesses 42 and 43 with respect to the mounting surface 11a, and dimensions of respective parts

are set such that the optical fiber cores **31a** and **32a** are disposed opposite the light inlet and outlet ports of the optical element **24**, in this example, light inlet and outlet ports of the wavelength selective optical waveguide, that is, such that their optical axes are aligned with each other.

In the case of the optical element **24** providing with the convexity **23** or concavity **51**, too, the optical element **24** may be an optical waveguide, vertical-cavity surface-emitting element, or the like. The optical part may also be a microminiature lens, or the like.

While in the above the optical element chip **21** and the platform **11** have each been described to be formed of single crystal silicon, they may be made of GaAs, crystal, ceramics, glass, or plastics. In the case of forming a concavity in the optical element chip **21**, the material needs to be transparent to light of the working wavelength band of the optical element assembly, such as the optical communication wavelength band. The convexity or concavity of the optical element chip and the element mounting part and the part receiving recesses of the platform can be formed by dry etching of the above-mentioned materials. In particular, in the case of single crystal GaAs or crystal, anisotropic etching based on its crystal orientation can also be used. The platform can be formed by molding of the plastic material. In the case of using silicon and glass for the optical element chip and the platform, they may also be fused together. In the present invention, the optical element assembly may be one that has the optical element chip mounted on the platform or one that has the optical parts mounted on the platform. While in the above the present invention has been described to form the optical element chip and the platform by means of photolithography, ultraviolet rays lithography or electron beam lithography.

What is claimed is:

**1.** An optical element assembly in which an optical part is mounted on a platform for optical coupling to an optical element of an optical element chip mounted on said platform, wherein:

- said optical element chip has said optical element formed on the bottom of a concavity in one side of a chip body;
- a convexity is formed as an element mounting portion on a mounting surface of said platform on which said optical part is to be mounted;
- said optical element chip is mounted on said mounting surface with said concavity of said optical element chip

engaged with said convexity of said element mounting portion so that said optical element is positioned with respect to said mounting surface; and

said optical part is positioned with respect to said mounting surface and mounted thereon, and a part receiving recess is formed in said mounting surface of said platform to establish optical coupling between said optical part and said optical element; wherein: the position of said optical element with respect to said mounting surface is a position which is determined by surface-to-surface contact between a pair of opposed side surfaces of said concavity and a pair of opposed wall surfaces of said element mounting portion and where said optical element is parallel to said mounting surface in the direction of arrangement of said side surfaces and said wall surfaces; and the position of said optical part with respect to said mounting surface is a position which is determined by contact between opposed wall surfaces of said part receiving recess, which are parallel to said pair of opposed wall surfaces of said element part, respectively, and said optical part in the direction of arrangement of said pairs of opposed wall surfaces.

**2.** The optical element assembly of claim **1**, wherein: said element mounting portion is a quadrangular frustoidal portion surrounded by a square-frame-like V-groove formed in said mounting surface; the height of said optical element from said mounting surface is determined by the width of said protruding end face of said convexity of said element mounting portion between marginal edges of said pair of side surfaces of said convexity; said optical element is parallel to said mounting surface; said part receiving recess has opposed wall surfaces parallel to a direction perpendicular to the direction of arrangement of said opposed side surfaces of said element mounting portion; and the height of the optical axis of said optical part from said mounting surface is determined by said contact between said opposed wall surfaces of said part receiving recess and said optical part.

**3.** The optical element assembly of claim **2**, wherein said part receiving recess is a V-groove.

\* \* \* \* \*