

(19) World Intellectual Property Organization
International Bureau



(43) International Publication Date
16 November 2006 (16.11.2006)

PCT

(10) International Publication Number
WO 2006/121463 A2

(51) International Patent Classification:
A61N 1/04 (2006.01)

KG, KM, KN, KP, KR, KZ, LC, LK, LR, LS, LT, LU, LV, LY, MA, MD, MG, MK, MN, MW, MX, MZ, NA, NG, NI, NO, NZ, OM, PG, PH, PL, PT, RO, RU, SC, SD, SE, SG, SK, SL, SM, SY, TJ, TM, TN, TR, TT, TZ, UA, UG, US, UZ, VC, VN, YU, ZA, ZM, ZW.

(21) International Application Number:
PCT/US2005/040013

(22) International Filing Date:
2 November 2005 (02.11.2005)

(84) Designated States (unless otherwise indicated, for every kind of regional protection available): ARIPO (BW, GH, GM, KE, LS, MW, MZ, NA, SD, SL, SZ, TZ, UG, ZM, ZW), Eurasian (AM, AZ, BY, KG, KZ, MD, RU, TJ, TM), European (AT, BE, BG, CH, CY, CZ, DE, DK, EE, ES, FI, FR, GB, GR, HU, IE, IS, IT, LT, LU, LV, MC, NL, PL, PT, RO, SE, SI, SK, TR), OAPI (BF, BJ, CF, CG, CI, CM, GA, GN, GQ, GW, ML, MR, NE, SN, TD, TG).

(25) Filing Language: English

(26) Publication Language: English

(30) Priority Data:
60/625,071 5 November 2004 (05.11.2004) US
60/676,514 2 May 2005 (02.05.2005) US

Declarations under Rule 4.17:

- as to the identity of the inventor (Rule 4.17(i))
- as to applicant's entitlement to apply for and be granted a patent (Rule 4.17(ii))
- as to the applicant's entitlement to claim the priority of the earlier application (Rule 4.17(iii))
- of inventorship (Rule 4.17(iv))

(71) Applicant and

(72) Inventor: HURTADO, Arthur, F. [US/US]; 7750 Big Rock Drive, Riverside, CA 92509 (US).

(74) Agent: SCHAAP, Robert, J.; 21241 Ventura Blvd. Suite 188, Woodland Hills, CA 91364 (US).

Published:

- without international search report and to be republished upon receipt of that report

(81) Designated States (unless otherwise indicated, for every kind of national protection available): AE, AG, AL, AM, AT, AU, AZ, BA, BB, BG, BR, BW, BY, BZ, CA, CH, CN, CO, CR, CU, CZ, DE, DK, DM, DZ, EC, EE, EG, ES, FI, GB, GD, GE, GH, GM, HR, HU, ID, IL, IN, IS, JP, KE,

For two-letter codes and other abbreviations, refer to the "Guidance Notes on Codes and Abbreviations" appearing at the beginning of each regular issue of the PCT Gazette.

(54) Title: EXERCISE AUGMENTING SELF-CONTAINED ELECTRO-STIMULATOR AND METHOD

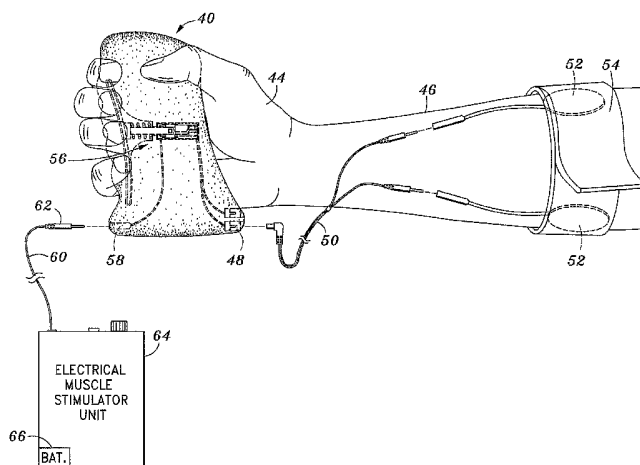

(57) Abstract: Exercise augmented by a self-contained electro-stimulator, and a method of augmenting exercise with electro-stimulation. The apparatus and the method rely upon electrical charges being applied to selected muscles of the arms or legs and, for that matter, the abdomen or even other portions of the body, by means of a belt or similar device worn about the selected portion of the body during exercising. The electrical charges cause further contraction of the muscles which increases the amount of the electrical stimulation, and in like manner, release of the muscles reduces the electrical stimulation. Unique size adjustable electrodes are provided. A unique approach to altering the number of electrodes used is disclosed. Further, a gripping device is disclosed and allows for electrical stimulus to electrically augment hand, wrist and forearm exercises. In addition, a disposable electrode is further provided.

WO 2006/121463 A2

TITLEEXERCISE AUGMENTING SELF-CONTAINED
ELECTRO-STIMULATOR AND METHODSPECIFICATION

BE IT KNOWN THAT I, Arthur F. Hurtado, a citizen of the United States and resident of the City of Riverside, State of California, have invented a certain new and useful exercise augmenting self-contained electro-stimulator and method of which the following is a specification containing the best mode of the invention known to me at the time of filing an application for letters patent therefor.

RELATED APPLICATIONS

This application is based on and claims for priority, the filing dates of my pending U.S. provisional patent application Serial No. 60/625,071, filed November 5, 2004, for "Methods of Eliminating the Number of Electrodes in an Abdominal Belt", and U.S. provisional patent application Serial No. 60/676,514, filed May 2, 2005, for "Electro-Augmented Gripping and Soft-Contained Abdominal Myociser", and the full disclosures of both such applications are incorporated herein by reference.

BACKGROUND OF THE INVENTION1. Field of the Invention

This invention relates in general to certain new and useful improvements in electro muscle stimulation in which selected muscles of the body can be stimulated to augment exercising and to improve muscle health, and improve neuropathways which control muscles of the body. More specifically, the present invention provides a unique hand grip exerciser having connection to belt placed around selected arm or other body muscles for augmenting the exercise of those muscles with electrical stimulation. In addition, the present invention provides unique belt arrangements in which the electrodes contained on the belt are constructed so that the number of electrodes can be reduced without sacrificing

the efficiency of operation of the apparatus.

2. Brief Description of Related Art

In my U.S. patent No. 6,876,883 dated April 5, 2005, there is provided an exercising apparatus having a rotateable component and in which an exercising belt is applied to the individual using the exercising apparatus and which is connected directly to components causing electro-stimulation of the muscles, along with an exercising routine. Although that apparatus is effective and highly useful for exercising muscles, it, nevertheless, requires an individual to assume a position in the exercising apparatus and also attach a belt or similar fabric article having the electrodes thereon so that the electrodes are selectively positioned over desired muscles of the body. One of the disadvantages of this generally stationary electro-stimulation apparatus is that it does not allow for the user to transport the stimulator to an area which may be conducive to the exercising along with the electro-stimulation. Moreover, because the user must necessarily acquire an exercising apparatus, the device obviously is not as portable and the cost is significantly higher than might otherwise be desirable.

In many cases, the conventional apparatus is not portable in the sense that there is a separate exercising apparatus apart from the actual muscle stimulating section. In this way, it is necessary for the user to transport the exercising device, if the latter is portable, as well as the stimulating apparatus.

In my U.S. patent No. 6,341,237, there is also provided a device for administering electro-muscle stimulation in the nature of a belt, which can be attached to the individual, and which belt contains a number of electrodes which are again positioned with respect to selected muscles of the human body in order to provide the electro-stimulation to the desired regions of the body. In essence, the belt, or similar device, is worn so that the positionable electrodes are effectively strategically placed upon a patient's body to stimulate a target group of muscles, or specific muscles, or muscle groups. The belt is designed to be

snugly wrapped around a portion of the patient's body containing the muscles which are to be stimulated. Electrodes on the belt will then be transcutaneously placed in contact with these muscles.

In accordance with this arrangement, when a party exercises, the physical exercise actually stimulates the muscle. However, when using these prior art stimulators, the electrical stimulus is also applied to the muscle further causing extension and contraction of the muscle, thereby, further creating an effective exercising and the benefits achieved thereby. As a result, these apparatus effectively augment the physical exercise of the individual.

It is apparent that with any physical apparatus which is not readily transportable, the individual must use that apparatus at a fixed location. In addition, and because the individual may not always be at the location of that apparatus, there are occasions when the augmented exercising cannot be employed. It would be desirable to provide a self-contained augmented exercise stimulating apparatus and a method therefor which is effectively portable and can be used in almost any location. It would also be desirable to provide an exercising apparatus with a minimum number of electrodes, but which are nevertheless sufficient and efficiently spaced to accomplish the exercise augmented muscle stimulation.

OBJECTS OF THE INVENTION

It is, therefore, one of the primary objects of the present invention to provide a self-contained, complete and compact muscle stimulator apparatus, which can be operated by a user to augment the user's exercising and which thereby allows the user to employ this muscle stimulating apparatus at a variety of locations which are not constrained by a large relatively non-transportable exercising apparatus.

It is another object of the present invention to provide a self-contained, complete and compact muscle stimulator apparatus adapted to apply electrical signals to a muscle through

electrodes effectively in contact with that muscle and which applies an electrical signal in response to a muscle contraction.

It is a further object of the present invention to provide a self-contained, complete exercise augmented muscle stimulating apparatus in which certain of the electrodes which might otherwise be used can be combined to make the device more efficient and reduce the cost of manufacture, as well as to improve the ease of use of the device.

It is an additional object of the present invention to provide a body wrapping band arrangement used with an electro-muscle stimulation apparatus for wrapping about a selected portion of the user's body, with electrodes adapted for different muscles or portions of muscles being consolidated without sacrificing the efficiency of the apparatus and which allows for consolidation of certain electrodes without compromising the electro-augmented exercising.

It is still a further object of the present invention to provide an apparatus of the type stated which can be manufactured at a relatively low cost, thereby, making the device highly affordable and widely useable and which will thereby become attractive to a large number of individuals who could benefit from exercise augmented electrical muscle stimulation.

It is a further object of the present invention to provide a method of augmenting muscle exercise through electrical stimulation with a self-contained exercising apparatus and which allows for attachment of a band to the portion of the torso or the limbs of a human body to efficiently achieve an exercising routine.

With the above and other objects in view, my invention resides in the novel features of form, construction, arrangement, and combination of parts and components presently described and pointed out in the claims.

BRIEF SUMMARY OF THE INVENTION

In a broad aspect, the present invention relates to a self-contained complete and compact muscle stimulator apparatus which

can be operated by a user to augment the user's exercising activities. In addition, the apparatus is also effective and can be operated without exercising by merely using the muscle stimulator. In most cases, the invention will be applicable to muscle stimulation in combination with exercising activity, although it is obviously effective without such exercising activity.

In a broad aspect, the invention relies upon the attachment of an encircling band or belt adapted to be used about a selected portion of the user's body. That selected portion may adopt, for example, the torso, such as an area encircling the abdomen, or any one of the limbs of the human body, such as the legs or arms thereof. The belt or other fabric member is provided with electrode means comprised of at least one positive electrode and one negative electrode. In actuality, there will be a plurality of positive electrodes and at least one negative electrode. In order to create a current path through the targeted muscle, it is usually necessary to have a positive electrode in combination with a negative electrode of substantially the same size or surface area. In this way, the stimulating current will pass from the positive electrode to the negative or return electrode through the targeted muscle. However, it is also possible to take advantage of the fact that it is possible to use a larger negative electrode for a pair of positive electrodes and a larger positive electrode when using a pair of separate negative electrodes.

The product of the invention utilizes electrical stimulus to electrically augment abdomen exercises and normal hand, wrist, forearm, and upper arm exercises. The purpose of this invention is also to augment and enhance natural exercise and encourage maximum muscle contraction, as well as a wide range of motion. It further facilitates the precise development of isolated muscle groups which may have become weak or have suffered a loss of neuromuscular function.

The invention operates on a principle that muscle fibers will grow in response to repeated contractions against a load,

or through electrical stimulation. A repetitive contraction over a substantial period of time will reduce toxic build-up and improve oxidative capacity and blood supply of the fibers. In case of injury, or where atrophy has occurred, repetitive contractions of muscles over a period of time not only reduces toxic buildup, but improves oxidative capacity and this, in turn, enhances a more speedy recovery and healing time.

The apparatus of the invention uses a muscle stimulation apparatus which is compact and self-contained. As a result, it can be carried with an individual and used in almost any location. The apparatus employs the generation of a continuous electrical stimulus in response to the use of a gripping device. This gripping device is responsive to pressure arising out of the gripping action of an individual, and this controls and regulates the intensity of the electrical output. This output is then directed to the electrodes on the band or other applicator.

In another embodiment of the invention, the gripping device is replaced by a compressive device, which is responsive to compressive movements of the individual. Thus, for example, if the individual uses compressive stomach lift exercises, the compressive action resulting from a shortening of the distance between two portions of the body will also cause generation of an output stimulus. The use of the exercising on an arm and forearm, as well as on the abdomen, are only two of the embodiments which can be employed using the apparatus of the invention.

In a preferred embodiment of the invention, in each of the aforesaid apparatus, the output stimuli to the muscles is regulated by a sliding potentiometer. However, it should be recognized that other means to vary the stimulus to the muscles in response to movement of the muscles could be employed.

When muscle contraction increases, there will be a proportional increase in electrical stimulus to the electrodes. In like manner, when there is a decrease in the compressive force, the electrical stimulus is proportionally reduced. In place of a sliding potentiometer, it is possible to use other

devices which are responsive to changes resulting from increased or decreased forces, as for example, internal air pressure similar to that of a blood pressure cuff. This causes a gradual voltage increase with increased gripping pressure and also stimulates the muscles involved. The voltage will reduce as the gripping pressure is released.

The electrodes on the belt are located in a pattern which matches a group of muscles of either the abdomen or the arms and legs. As the user exercises in one direction, stimulation is applied while contracting the muscles. As the user exercises in an opposite direction, stimulation is decreased.

The present also provides a unique electrode construction in which the size of the electrode can be expanded or reduced in order to accommodate a different sized individual, or for that matter, to achieve a different electrode arrangement. More specifically, an electrically conductive skin may be disposed over an electrically conductive plate and provide electrical communication through that skin. By adjusting the position of the skin with respect to the plate, the size of the electrode can be adjusted accordingly.

This invention possesses many other advantages and has other purposes which may be made more clearly apparent from a consideration of the forms in which it may be embodied. These forms are shown in the drawings forming a part of and accompanying the present specification. They will now be described in detail for purposes of illustrating the general principles of the invention. However, it is to be understood that the following detailed description and the accompanying drawings are not to be taken in a limiting sense.

BRIEF DESCRIPTION OF THE DRAWINGS

Having thus described the invention in general terms, reference will now be made to the accompanying drawings in which:

Figure 1 is a schematic view of a prior art stimulating apparatus in accordance with the present invention;

Figure 2 is a prior art schematic arrangement of electrodes on a belt of the type worn in electric stimulation, such as that illustrated in U.S. Patent No. 6,876,833;

Figure 3 is a plan view of an electrode pattern arrangement in which a pair of negative electrodes are consolidated in accordance with the present invention;

Figure 4 is a schematic wave diagram of the voltage applied with an electrode pattern of the type shown in Figure 3;

Figure 5 is a schematic plan view of another form of electrode consolidation in accordance with the present invention;

Figure 6 is a schematic plan view of still a further electrode pattern showing electrode consolidation in accordance with the present invention;

Figure 7 is a schematic plan view, showing still a further embodiment of a consolidated electrode pattern arrangement;

Figure 8 is a schematic plan view of yet another form of electrode pattern arrangement in accordance with the present invention;

Figure 9 is a somewhat fragmentary perspective view, showing a pliable and compressible hand-grippable device, in accordance with the present invention;

Figure 10 is a schematic plan view, showing the gripping of the device of Figure 9 when the latter has been compressed by the hand of a user;

Figure 11 is a plan view of a belt forming part of the apparatus of Figures 9 and 10;

Figure 12 is a somewhat schematic plan view of the details of construction of a slide potentiometer arrangement used in the hand-grip apparatus of Figures 9 and 10;

Figure 13 is a vertical sectional view taken along line 13-13 of Figure 12;

Figure 14 is a plan view of an individual using the muscle stimulating apparatus of the invention while in a crunch position;

Figure 15 is a plan view of the individual of Figure 14 when in the rest or reclined position;

Figure 16 is a fragmentary plan view of an individual in an upright position and wearing an abdomen belt containing a slide potentiometer in accordance with the invention;

Figure 17 is an enlarged plan view showing the details of the slide potentiometer in the belt of Figure 16;

Figure 18 is a perspective view of an electrode arrangement with the surface area thereof being increased in accordance with the invention; and

Figure 19 is an elevational view comprised of Figures 19A and 19B and showing the electrode arrangement of Figure 18 being increased in surface area.

DETAILED DESCRIPTION OF A PREFERRED EMBODIMENT

A device for administering electro-muscle stimulation, as shown in U.S. patent No. 6,341,237 dated January 22, 2002, and a device for applying variable electro-muscle stimulation is shown in my U.S. patent No. 6,876,883 dated April 5, 2005. Each of those devices were not necessarily small and compact and were not fully self-contained. In some cases, the apparatus comprised large, fixed structures which were not relatively mobile, thereby, causing the user to use the device at a fixed location. The difficulties of constraining an individual to use a system at a fixed location were described above.

The present invention overcomes this and related problems in the use of an exercising device, which is completely self-contained, compact and easily transportable, which can be carried with an individual for use at a selected time. Although this device may assume various embodiments, one such embodiment is hereinafter described in connection with Figures 9 -12.

Referring first to Figure 1, which discloses a prior art device, there is an extremity cuff embodiment 20 having a belt 22 with a first positive electrode 24 and a second positive electrode 26, along with a negative so-called "return" electrode 28. There is also provided a first voltage adjustment control 30 and a second adjustment control 32, both for applying first and second positive voltages. However, the device is

fixed, because it is used with an external exercise apparatus, and is also connected to a voltage/current source 34, as also shown in Figure 1. In this sense, the device is not completely portable and, moreover, must be used only in relation to a fixed source of electrical power.

The present invention overcomes this limitation in the provision of an apparatus 40, as shown in Figures 9-12 of the drawings. In this case, the apparatus is a highly transportable and constitutes a complete unit for treatment of neuromuscular conditions which may arise as a result of disease or injury to nerve fibers supplying a muscle or from other conditions. This apparatus operates with electrical stimulus to electrically augment normal hand, wrist, forearm, and upper arm exercise. It also facilitates development of specific muscle groups which have either become weak or have a loss of neuromuscular function.

The device of the present invention in this embodiment is embodied in the use of a gripping device 40, as specifically shown in Figures 9-12. This gripping device is comprised of a pliable and compressible silicone rubber hand shaped material mass 42 that is preferably fitted to a user's hand. In any event, it should be comfortably fitted and bio-mechanically correct in design for gripping purposes. In the embodiment of the invention, as shown in Figure 9, the gripping device 40 is sized to fit within the user's hand. However, it could be arranged with the mass being in the form of a gripping device which is fitted around the user's fingers and then held in the palm of the hand 44 of the user. In either case, it can be observed that the gripping device essentially well conforms to the user's hand allowing for exercising of the hand, or, for that matter, the individual fingers.

The material forming the hand grip should have the properties which allow elastic compressibility and return to its original size and shape when released. One of the materials which could be used in the compressible gripping device is similar to that currently used in stress relievers, such as hand exercise balls. Obviously, other materials, including silicone,

foams and the like, such as urethane foams, or the like.

The gripping device 40 may be connected to and is provided with a jack receptacle 48 (one of which is an active electrode and the other a return electrode) for connection through a cable set 50 to a pair of electrodes 52 contained on a belt 54 and one of which is active and the other a return electrode. The device is wrapped about the forearm of the individual. The electrodes 52 provide the output of electrical stimuli to the muscles. Regulation of the electrical signal is achievable with a moveable device, preferably in the nature of a gripping device 40, including a sliding potentiometer, as an integral and complete unit.

A stimulation signal control mechanism 56 controls the electrical signal and may include, for example, the aforesaid sliding potentiometer. However, any moveable device or instrument capable of detecting variable pressure applied by the user, and which, in response, controls electrical current output may be used for this purpose. The stimulation control mechanism 56 is hereinafter described in more detail.

The hand-gripping device 40 is also provided with another jack receptacle 58 which receives a cable set 60 connected to an electrical muscle stimulator unit 64. This muscle stimulator unit will also physically contain therein a battery 66, which may be either rechargeable or replaceable, as desired. If desired, the stimulator unit 64 could be constructed in a very small, compact unit and actually physically affixed to the gripping device 40. In either case, the electrical current necessary for operation of the device is provided by the battery 66.

The belt 54 is more fully shown in Figure 11 of the drawings. In this case, the belt can be wrapped about the forearm of a user and releasably secured in that position. Otherwise, for abdomen exercising, another belt having components similar to that shown in Figure 11 could be employed and would also be releasably secured about the user in a desired position. In the embodiment as shown in Figure 11, an electrode 52 can be mounted on a slide 70, so that the latter may be shiftable along

the band to a desired position. The band is also conventionally provided with a fiber fastening attachment strip 72, as well as an opposite and cooperating fiber fastening attachment strip 74, all as best show in Figure 11.

The stimulator control mechanism is shown in the enlarged views of Figure 11 and Figure 12 and comprises a sliding potentiometer 70 similar to the potentiometer 56 which is placed internally within the gripping device. When a compressive pressure is applied to the device, the slide of the potentiometer is actuated, that is, pushed inwardly, reducing electrical resistance generated by the stimulator. This produces an increase in electrical stimulus to the electrodes 52, resulting in muscle contraction. Alternatively, as the participant releases the gripping force, the original shape of the gripping device is restored. Moreover, the slide potentiometer then increases the resistance, resulting in a decrease of stimuli to the electrodes.

The slide potentiometer comprises a moveable rod 72 connected to a plate 74 and which is arcuately shaped to essentially conform to a gripping palm of a user. The moveable rod 72 is biased outwardly from a coil 82 by a spring 76 which receives the arm 72, or otherwise, an extension of that arm. When the arm 72 moves within the coil, it will operate to either increase or decrease the signal through inductive coupling. The spring 76 will always bias the arm 72 outwardly, that is, to the left as shown in Figure 12, against the action of a gripping force. There is also provided a backstop 78 arranged to receive the end of the arm 72 forming part of the sliding potentiometer and stop the movement at that point.

When exerting pressure on the gripping device, a concurrent electrical stimulus is directed to the muscles responsible for performing a specific activity, such as that of gripping. The stimulus becomes quantitatively coupled with the gripping force which may be applied by the participant. The electrodes 52 are placed on the muscles that are causing this action. By going through a range of motion in harmony with the stimulus, muscle

response is magnified to even slight voluntary muscle activity. Furthermore, the neuromuscular pathways become facilitated, or retrained. By controlling the amount of pressure applied to the grip, the user has the capability of controlling the amplitude and duration of stimuli to the effected muscles. This also provides for psychological and physiological advantages, in that the participant takes an active role in any type of rehabilitation.

Figure 9 illustrates the use of the electro-augmented gripping device augmenting exercise of the forearm by gripping. However, the same principles may be applied with exercise involving the biceps and triceps.

In the case of exercising the bicep muscles, the cuff 54 is applied to the upper arm and the electrodes 52 are placed over the biceps. As the user actuates the biceps by exerting arm flexion, the user simultaneously applies pressure to the gripping device delivering electro-stimulation to the biceps. As the user relaxes the biceps by extending the arm, the user simultaneously releases the pressure of the gripping device thereby decreasing the stimulation to the biceps.

In the case of exercising the triceps muscles, the cuff 54 is applied to the upper arm and the electrodes 52 are placed over the triceps. As the user actuates the triceps by exerting arm extension, the user simultaneously applies pressure to the gripping device delivering electro-stimulation to the triceps. In like manner, as the user relaxes the triceps by flexing the arm, the user simultaneously releases the pressure of the gripping device thereby decreasing the stimulation to the triceps.

Electro-augmented exercise is unique in that, with respect to muscle development, the muscles become more fully contracted to a further level than is possible using only voluntary contraction or through normal exercise.

Figures 14 and 15 show a muscle stimulating apparatus 90 in accordance with the present invention, which is used about the abdomen of the individual for applying electro-stimulation to

muscles in the abdomen. The exerciser 92 would initially assume a rest or reclined position, as shown in Figure 15, and from that, move to a partial sit-up position where the shoulders are moved off of a floor or supporting surface to that, as shown in Figure 14. When assuming this latter position, rectus abdominus and oblique muscles are exercised.

The belt 90 is shown on an upright individual 94 in Figure 16. In this case, and in the case of the belt 90 used on the abdomen, the construction would be similar to that shown in Figures 9-11 of the drawings. The muscle stimulator apparatus would also include an electro-stimulus control device 94 similar to that used in a hand-gripping mechanism of the type previously described. In this case, the control device 94 is more fully illustrated in Figure 17 of the drawings. This control apparatus similarly includes a sliding potentiometer 96 of similar construction to that used in the hand-grip apparatus and would include an arm 98 similar to the arm 72 biased against a contraction by means of a spring 100 similar to the spring 76. The remaining details of construction of the sliding potentiometer mechanism are similar to those previously described in connection with the hand-gripping apparatus and are, therefore, not described in any further detail herein.

In the embodiment of the invention as shown in Figures 14-16 and 17 of the drawings, operating as an abdominal muscle stimulator, it can be seen that as the user exercises in a first direction, stimulation is applied to the subject's contracting muscles in the abdomen. When the user exercises in the opposite direction, decreased stimulation is applied to these muscles of the user. The electrodes (not shown in this embodiment) are disposed on the belt 90 in a pattern, which matches a group of muscles of the abdomen. These muscles include the upper rectus abdominis ("URA"), the lower rectus abdominis ("LRA"), the right oblique ("RO") and the left oblique ("LO").

This device eliminates the need for an external abdomen exercise apparatus. Moreover, the positional detecting device may adopt any form which is capable of causing the generation of

an electrical signal in response to the movement of the abdomen. This detecting device has a transducer which will govern the intensity of the stimulation generated by the generator therefor

It is also possible to use a slide potentiometer in which the potentiometer operates as a transducer. That transducer communicates the angular position of the abdomen and regulates the stimulation applied by the generator. As the user performs a crunch, the distance between the lower and upper abdominis rectus muscles becomes shorter, providing a means of actuating a stem of a slide potentiometer, and this will regulate the current intensity.

Another detecting device which may be used is one which senses the electrical activity of the contracting and relaxing muscles. As a crunch is performed, instrumentation will deliver a signal responsive to that activity to a computer. In this way, an appropriate electrical stimulus is monitored and a responsive signal can be generated.

Thus, the present invention has shown two forms of abdominal exercising stimulators, which are only exemplary of the number of embodiments which can be employed. In substance, any moveable member, which moves within a potentiometer, or a coil, and in response to movement of a muscle, can generate the desired response. The source of power may be conveniently applied to the device itself, or, if desired, it can be connected to a separately disposed source of power.

The invention also provides a method and a belt having a uniquely designed electrode arrangement and a method of consolidating the number of electrodes in a belt, as for example, in an abdominal belt, or a belt to be disposed about the limbs of a user. One conventional form of belt is illustrated in Figure 2 of the application and is described in and illustrated in Figure 2 of my U.S. patent No. 6,876,883 dated April 5, 2005, and in my co-pending U.S. continuation patent application Serial No. 11/046,496, filed January 28, 2005, for a Method For Applying Variable Electro-Muscle Stimulator And System Therefor.

To increase the efficiency and reduce the cost of

construction of a belt with a number of electrodes, it is possible to eliminate some of these electrodes, as long as the elimination is performed in a manner which allows the belt to maintain optimum control of the muscles being stimulated and still minimizing a loss of efficiency.

Electrodes which may be more suited for consolidation are those associated with the return electrodes located generally in a horizontal arrangement in the belt. The conventional arrangement, as shown in U.S. patent No. 6,876,883, is also more fully illustrated in Figure 2 of the present drawings, as aforesaid. In this case, there is a belt 90 having 4 positive electrodes and 3 negative electrodes connected in the manner as shown in Figure 2 herein. Although these electrodes are identified by reference numerals herein, they are sometimes identified by letter codes. The letter codes also used in the identification of these electrodes is also set forth below:

URAE	Upper Rectus Abdominis Electrode	LLOE	Left Lateral Oblique Electrode
LRAE	Lower Rectus Abdominis Electrode	LROE	Left Rectus/Oblique Electrode
CUE	Central Umbical Electrode	BCOE	Balance Control for Right and Left Oblique Electrodes
RLOE	Right lateral Oblique Electrode	BCAR	Balance Control for Upper and Lower Abdominis Rectus
RROE	Right Rectus/Oblique Electrode		

The electrodes which are most suited for consolidation are three of the negative electrodes along the mid-horizontal line of Figure 2 passing through the belt. Thus, by referring to Figure 2, the normal electrode arrangement is shown.

By referring to the prior art illustration of Figure 2, there are three normal return electrodes 96, 100 and 102. There are four positive electrodes, such as the left lateral oblique electrode 98 (also identified as "LLOE"), and the right lateral oblique electrode 104 (sometimes referred to as "RLOE"), the lower rectus abdomen electrode 94 (sometimes referred to as

"LRAE") and the upper rectus abdomen electrode 92 (sometimes identified as "URAE"). The return electrode 100 is sometimes referred to as the left rectus/oblique electrode (or "LROE") and the return electrode 96 is sometimes referred to as the central umbilical electrode ("CUE"), and the latter return electrode, namely 102, is referred to as the right rectus oblique electrode ("RROE"). Finally, there are typically two balance controls 106 and 108. The balance control 106 is a balance control for the right and left oblique electrodes (sometimes referred to as "BLOE"), and the balance control 108 is for the upper and lower abdominus rectus (sometimes referred to as "BCAR").

It can be seen that the central umbilical return electrode CUE would be located at a point proximate the umbilical region, the return electrode LROE would be placed proximal the left rectus/oblique junction, and the right return electrode RROE would be placed proximate the right rectus/oblique junction. In substance, one of the simplest ways to consolidate electrodes would be to consolidate the return electrodes 100 LROE and 102 RROE into the electrode CUE. In this way, there will be a single return electrode located at the umbilical region in Figure 2.

When combining electrodes, as described, it becomes apparent that the balance controls will operate in conjunction with and share one common return electrode, namely the electrode CUE. In this case, it can also be observed that this consolidated electrode is of size sufficient to disperse the increased concentration of electro-stimulus.

In order to consolidate electrodes, the electrodes 100 and 102 could be consolidated with the CUE electrode 96 into a single return electrode 110, as shown in Figure 3. In this way, there is only a single return electrode at the umbilical region, namely, the electrode 110. Thus, the two channels identified by the balance controls will share one common return. Obviously, and as indicated above, these consolidated electrodes necessarily must be of sufficient size to disburse any increased concentration of electrical stimulus.

When considering the configuration of Figure 3, it can be observed that there are essentially the two active lateral electrodes, namely the left lateral oblique electrode 98 and the right lateral oblique electrode 104. The lateral electrodes stimulate the right and left oblique muscles and constitute the first channel with the balance control 106. The vertical electrodes constitute the previously identified upper rectus abdominus electrode 92 and the lower abdominus rectus electrode 94, which would constitute a second channel with the balance control 108. In this configuration, the electronic stimulator unit is designed to alternately stimulate the set of vertical electrodes and the muscles in contact therewith and then the lateral electrodes and the set of lateral muscles in contact therewith. While the vertical electrodes are being stimulated, the lateral electrodes are off. In like manner, while the lateral electrodes are being stimulated, the vertical electrodes are off.

A current sufficient for operation of these electrodes is set forth in Figure 4. It can be observed that biphasic symmetrical square wave pulses, which alternate between the vertical and horizontal sets of electrodes, are used. It can also be observed by reference to Figure 4 that there is a first wave form 116 having current pulses 118, and a second wave form 120 having current pulses 122. The current pulses 118 are offset from the current pulses 122. Thus, the stimulation between vertical and lateral electrode pairs alternates at a high frequency. In fact, this frequency is sufficiently high that there is a perception by the user that the vertical and lateral muscles are being simultaneously stimulated.

In order to accommodate the return currents, the surface areas of the return electrodes equal the surface areas of the active vertical electrodes. The same holds true of the active horizontal electrodes. In one embodiment, each active electrode has the same surface area, and the return electrodes would be

twice that of each active electrode, where two active electrodes are sharing the same return electrode.

Another embodiment of the invention utilizing alternate channels also involves further elimination of the upper abdominus rectus electrode 94. By reference to Figure 5, it can be seen that there is a return electrode 96, which is a common return electrode for the right oblique active electrode 104 and the left lateral oblique active electrode 98, which would constitute a first channel, with the balance control 106. The central umbilical return electrode 96 and the lower rectus abdominis active electrode 126 constitute channel 2. The vertical balance control 108 is eliminated in this embodiment.

Consolidation of the return electrodes could result in an inability to isolate the respective current flows of the two channels. The currents of these channels flow in a perpendicular direction, and it may therefore be necessary to further isolate the respective currents for improved control and muscle isolation. A proposed solution results in a further circuit arrangement of the type shown in Figure 6, by creating a modified electrode or tri-electrode with inter-electrode insulation.

By examining Figure 6, it can be seen that there is a new tri-electrode 131 comprised of electrode sections 130, 132 and 133 and which effectively consolidates the electrodes 100, 102 and 96. The other electrodes essentially remain the same. The tri-electrode 131 essentially comprises the three conductive sections, such as the sections 130, 132, and 133, and all of which are insulated by electrically insulative materials 134. This effectively insulates each of the three electrodes, left rectus oblique electrode 100, the right rectus oblique electrode 102, and the central umbilical electrode 96.

This new consolidated return electrode may vary in transverse size, depending upon the extent of the muscles which are to be stimulated. A smaller size electrode may be limited to extend only across the rectus abdominus muscle, while a larger sized tri-electrode may extend across the rectus abdominus and further make partial contact with the oblique muscles

bilaterally. The electrode 132 will serve as a return for channel 1, and the electrode sections 130 and 133 will serve as a return for the channel 2. The current flow for channel 1 is oriented in a perpendicular direction to the current flow of channel 2.

A further electrode design is shown in Figure 7, which provides a four-electrode belt. This involves the elimination of the upper rectus abdominus electrode 92 in Figure 6. More emphasis is normally placed in stimulation of the lower rectus abdominus rather than the upper rectus abdominus. The lower rectus abdominus is more difficult to exercise and typically becomes a neglected area. With less emphasis on the upper rectus abdominus, the positive upper rectus abdominus electrode can be eliminated, and this also affords additional room to adjust the location of the central return electrode 131. Thus, the central return electrode can be located at a further distance from the positive lower rectus abdominus electrode. This will avoid the discomfort or stinging sensation of edge effect caused by close proximity of these electrodes.

Better control is achieved in stimulating the oblique muscles with an arrangement as shown in Figure 8. This configuration, as shown in Figure 8, is quite similar to the configuration as shown in Figure 2. However, in this case, the upper rectus abdominus electrode 92 has been eliminated. In this case, there is more room to adjust the central umbilical electrode 96. This results in a six-electrode configuration. Current diverter or balance control 106 is also used in this arrangement for channel 1, as in the previous arrangements. However, the balance control 108 for channel 2 is eliminated. The first channel, such as channel 1, would include the left lateral oblique electrode 98 and the right lateral oblique electrode 104, as well as the return electrodes 100, 102 and balance control 106. The second channel would actually constitute the return electrode 96 and the active electrode 94. The balance control 108 is eliminated. The balance controls

provide a method to reduce the number of channels or units necessary to perform the functions of the belt.

In many cases, where the user may be exceptionally large, the electrodes would not normally lie directly over the muscles which require stimulation. Moreover, it is known that a larger electrode provides a more comfortable stimulation, and this disperses the concentration of current, thereby, diminishing any sharp and stinging sensation which would be experienced with a smaller electrode. A larger electrode also has a greater contact area, stimulating a greater number of neuro-muscular receptors. This combination of a more dispersed current and stimulation of a greater number of neuro-muscular receptors provides for a more comfortable and efficient stimulation.

One such arrangement is shown in Figures 18 and 19 of the drawings and which allows for adjustment of the size of the electrode. In this case, there is an electrode base 150 which is affixed onto a belt, such as in Figure 3, and may be formed of a flexible material, such as a carbon base, and which is adapted to be applied to the skin of a user over a muscle to be stimulated. Facewise disposed over the base 150 is a conductive skin 152, or so-called "pad", as shown in Figure 18. In the right-hand portion of Figure 18, it can be observed that the pad can be shifted partially to the right with respect to the base 150. In this way, the size of the electrode is made larger. This arrangement is also shown in Figure 19A, in which the pad 152 is placed directly on the base pad 150. However, in the right hand version of Figure 19B, the pad 152 is offset partially with respect to the base 150. Moreover, there is a lead cable 154 on the electrode base 150, as shown in both Figure 19A and Figure 19B. This electrode arrangement, as shown in Figures 18 and 19, provides a method for adjusting the size of the electrode. This is highly useful in adjusting the surface area of the electrode to stimulate oblique muscles, since they vary greatly in size, with different waist sizes. This embodiment effectively consists of a conductive base affixed to a garment, and the conductive pad is located over the base. The

area size of the electrode can thereby be adjusted by positioning the placement of the pad electrode with respect to the base.

In addition, the conductive pads also provide an economical advantage, in that the pads are disposable and utilize a method of affixing the pads to the base through an adhesive coupled with a conductive gel. In this embodiment the disposable pads do not require the use of snaps, or other fasteners, or connective cables or leads.

Thus, there has been illustrated and described a unique and novel exercise augmenting self-contained electro-stimulator and method and which thereby fulfills all of the objects and advantages which have been sought. It should be understood that many changes, modifications, variations and other uses and applications which will become apparent to those skilled in the art after considering the specification and the accompanying drawings. Therefore, any and all such changes, modifications, variations and other uses and applications which do not depart from the spirit and scope of the invention are deemed to be covered by the invention.

CLAIMS

Having thus described the invention, what I desire to claim and secure by letters patent is:

1

A self-contained complete and compact muscle stimulator apparatus which can be operated by a user to augment the user's exercising, said apparatus comprising:

- a) an encircling band adapted to be used about a selected portion of a user's body;
- b) current controlling means including a moveable member which moves in response to an applied force;
- c) an electrode means associated with said band and being connected to said current controlling means and receiving an electrical current in response to and proportional to the movement of the moveable member;
- d) power supply means operatively connected to said current controlling means and providing the electrical current in response to the motion of said moveable member; and
- e) said current controlling means and power supply means being connected as a single small compact unit and being electrically connected to said electrode means.

2

The self-contained complete and compact muscle stimulator apparatus of Claim 1 further characterized in that said applied force comprises:

24

- a) a contraction of a muscle which causes movement of the moveable member.

3

The self-contained complete and compact muscle stimulator apparatus of Claim 1 further characterized in that said band is sized and shaped to fit about one of an abdomen or a limb of the human body.

4

A self-contained complete and compact muscle stimulator apparatus of Claim 2 further characterized in that said current controlling means comprises:

- a) a squeezable member;
- b) said moveable member being mounted to said squeezable member and being adapted to move in response to the amount of a squeezing action on said squeezable member and thereby causing delivery to a muscle of an electrical current proportional to the squeezing action.

5

The self-contained complete and compact muscle stimulator apparatus of Claim 4 further characterized in that said moveable means comprises:

- a) an armature;
- b) a coil in which said armature moves;
and
- c) spring means opposing the squeezing action.

6

A self-contained complete exercise augmented muscle stimulating apparatus adapted to apply an electrical signal to

25

a muscle in response to muscle contraction, said apparatus comprising:

- a) application means for applying and releasably holding a flexible substrate to a selected portion of a user's body;
- b) at least one positive electrode located to apply an electrical signal to a muscle at said selected portion of the body in response to contraction of said muscle; and
- c) at least one negative electrode located to cooperate with said positive electrode and complete an electrical current path with said muscle for operation of said apparatus.

7

The self-contained, complete exercise augmented muscle stimulating apparatus of Claim 5 further characterized in that said apparatus further comprises:

- a) a plurality of positive electrodes on said substrate spaced apart from one another to apply electrical signals to different parts of a user's body; and
- b) a plurality of negative electrodes cooperating with said positive electrodes to complete electrical current paths with said muscle.

8

The self-contained complete exercise augmented muscle stimulating apparatus of Claim 6 further characterized in that:

- a) a fabric band adapted to be secured about a portion of a user's body in that at least one positive electrode and at least one negative electrode are properly positioned with respect to one or more selected muscles.

9

26

The self-contained complete exercise augmented muscle stimulating apparatus of Claim 6 further characterized in that said application means further comprises:

- a) a fabric band adapted to be worn about a limb of a user with fastening means to be secured to itself.

10

The self-contained complete exercise augmented muscle stimulating apparatus of Claim 6 further characterized in that said stimulator apparatus further comprises:

- a) a transducer having a moveable member which moves in response to and proportionally to muscle contractions; and
- b) means associated with said transducer to control application of electrical current applied in response to amount of movement of said moveable member.

11

A band apparatus used in electro-muscle stimulation on a selected portion of a user's body with electrodes adapted for different muscles or portions of a muscle being consolidated without sacrificing efficiency of the apparatus, said apparatus comprising:

- a) a band configured and sized to encircle a portion of a user's body;
- b) a plurality of positive electrodes on said band and being positionable in contact with and over selected muscles or groups of muscles, each positive electrode requiring a negative ground path to enable completion of an electrical circuit loop to allow electrical stimulation; and
- c) at least one negative electrode on said band and also being in contact with the user's body, said negative electrode cooperating with and enabling

27

completion of a negative ground path with a plurality of positive electrodes, such that a plurality of positive electrodes may form an electrode pair and a complete circuit loop with one negative electrode allowing electrical stimulation to be applied to a selected muscle;

12

The band apparatus of Claim 11 further characterized in that said apparatus comprises:

- a) a pair of positive rectus abdominis electrodes constituting one pair of the plurality of positive electrodes and which would normally provide a separate negative ground path for both positive electrodes;
- b) a single separate negative electrode for each of the electrodes in the pair of positive electrodes, such that one negative electrode establishes a negative ground path for each positive electrode.

13

The band apparatus of Claim 11 further characterized in that said apparatus comprises:

- a) a pair of positive electrodes constituting one pair of the plurality of positive electrodes and which would normally provide a separate negative ground path for both positive electrodes;
- b) a single separate negative electrode for each of the electrodes in the pair of positive lateral oblique electrodes such that one negative electrode establishes a negative ground path for each positive electrode.

14

28

The band apparatus of Claim 11 further characterized in that said apparatus comprises:

- a) a pair of positive rectus oblique electrodes constituting one pair of the plurality of positive electrodes and which would normally provide a separate negative ground path for both positive electrodes;
- b) a single separate negative electrode for each of the electrodes in the pair of positive electrodes, such that one negative electrode establishes a negative ground path for each positive electrode.

15

The band apparatus of Claim 11 further characterized in that the surface area of the negative electrode is about twice that of each positive electrode.

16

The band apparatus of Claim 11 further characterized in that a first biphasic current is used to operate one of the positive electrodes and a second biphasic current is used to operate the second of the positive electrodes.

17

A band apparatus used in electro-muscle stimulation on a selected portion of a user's body with electrodes adapted for different muscles or portions of a muscle being consolidated without sacrificing efficiency of the apparatus, said apparatus comprising:

- a) a band configured and sized to encircle a portion of a user's body;
- b) a positive electrode on said band and being positionable in contact with and over selected muscles or groups of muscles each positive electrode requiring a negative ground path to

29

enable completion of an electrical circuit loop to allow electrical stimulation; and

- c) said positive electrode comprising a plurality of positive electrode cells with each being insulated from one another; and
- d) at least one negative electrode on said band and also being in contact with the user's body, said negative electrode cooperating with and enabling completion of a negative ground path with a plurality of said positive electrodes, such that a plurality of positive electrodes may form separate positive electrical cells and with the at least one negative electrode forming an electrode pair and a complete circuit loop with one negative electrode allowing electrical stimulation to be applied to a selected muscle contracted by the positive electrode cell;

18

The band apparatus of Claim 17 further characterized in that said positive electrode comprises;

- a) an electrically conductive member;
- b) at least one insulator associated with said electrically conductive member forming a plurality of positive electrode cells with each being insulated from the other; and
- c) a single electrical conductor operatively connected to said electrode cells.

19

A method of augmenting muscle exercise through electrical stimulation with a self-contained body applicable exercising apparatus, said method comprising:

- a) applying to one of the torso or limb of a human body a stimulator with a plurality of electrodes

30

- therein to complete an electrical circuit through a muscle with a self-contained power source;
- b) moving a portion of the human body to exercise said muscle;
 - c) moving a moveable member of a transducer to cause generation of an electrical signal proportional to movement of the moveable member;
 - d) generating an electrical current of size proportional to the amount of movement of the moveable member; and
 - e) applying that current to the muscle to augment contraction and expansion of the muscle.

20

The method of augmenting muscle exercise of Claim 19 further characterized in that the method of applying a stimulator further comprises:

- a) wrapping a fabric band about a portion of the torso of a human body or about a portion of one of the limbs of that human body; and
- b) positioning at least one transducer with respect to a muscle to be stimulated, such that electrical current is delivered to that muscle in response to muscle extension or contraction.

21

The method of augmenting muscle exercise of Claim 19 further characterized in that said method comprises:

- a) the moving of the moveable member of said transducer occurs when a muscle is contracted or extended through movement of the body.

22

The method of augmenting muscle exercise of Claim 19 further characterized in that said method comprises:

31

- a) squeezing a member with the hand of an individual thereby causing movement of the moveable member in said transducer and thereby causing the generation of a muscle applied electrical stimulus.

23

The method of augmented muscle exercise of Claim 19 further characterized in that said method further comprises:

- a) combining a pair of negative electrodes into a single negative electrode and permitting a pair of positive electrodes to operate with a complete circuit path through that negative electrode; and
- b) regulating the current applied to the positive electrodes to allow the use of a single combined negative electrode.

24

The method of augmenting muscle exercise of Claim 19 further characterized in that said method further comprises:

- a) combining a pair of positive electrodes into a single positive electrode and permitting a pair of negative electrodes to operate with a complete circuit path through that positive electrode; and
- b) regulating the current applied to the negative electrodes to allow the use of a single combined positive electrode.

25

An electrode assembly which is capable of being extended and contracted to conform to a desired position on a user of a muscle stimulating system to properly cover and stimulate a desired area, said assembly comprising:

- a) a flexible plate which is electrically conductive and adapted to be applied to the skin of a user;

32

- b) a conductive foil capable of being placed over at least a portion of said plate and being adjustably positionable with respect to the said plate to increase the surface area of the skin covered or reduce the surface area of the skin covered;
- c) electrical contacts connected to said plate and to said foil in order to complete an electrical circuit through the skin of the user.

26

The assembly of Claim 25 further characterized in that said assembly further comprises:

- a) means associated with one of said electrical contacts for application to a positive source of electrical current; and
- b) means associated with the other of said electrodes for connection to a negative ground source in order to complete a current path through the user.

27

The assembly of Claim 25 further characterized in that said plate has an electrical bus connected thereto for connection to said electrical contacts.

28

The assembly of Claim 25 further characterized in that said foil and said plate have approximately the same size and surface areas.

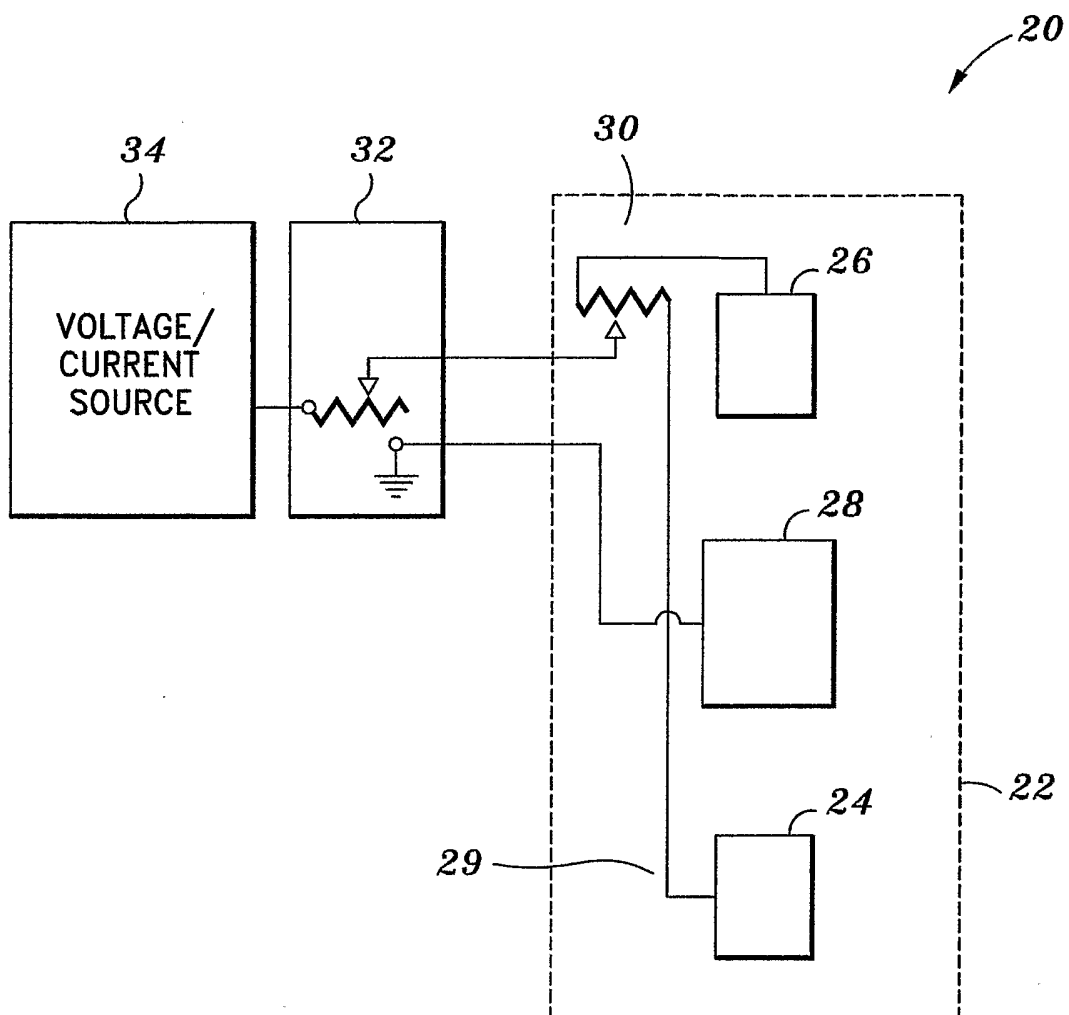

Fig. 1
(PRIOR ART)

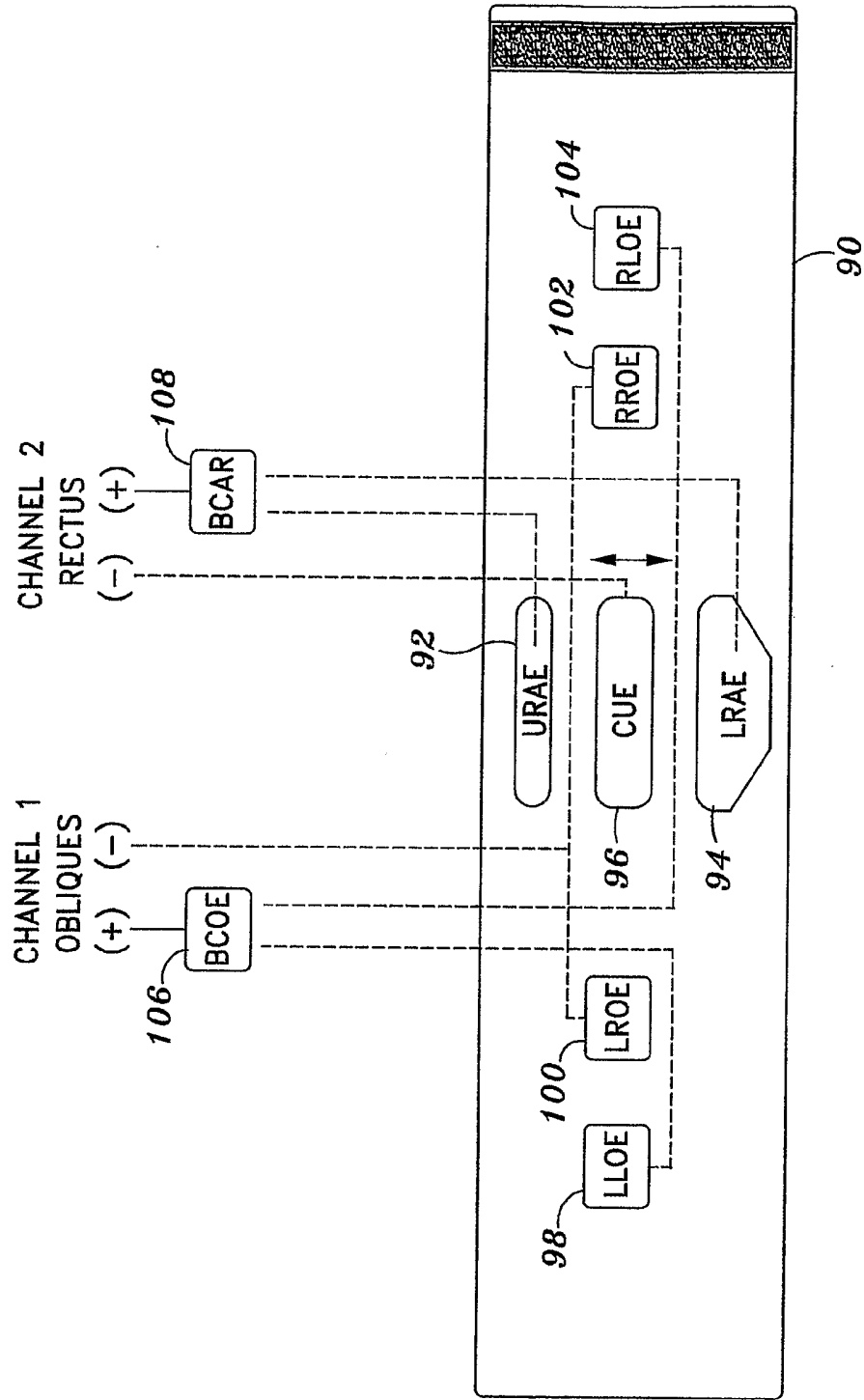

Fig. 2
(PRIOR ART)

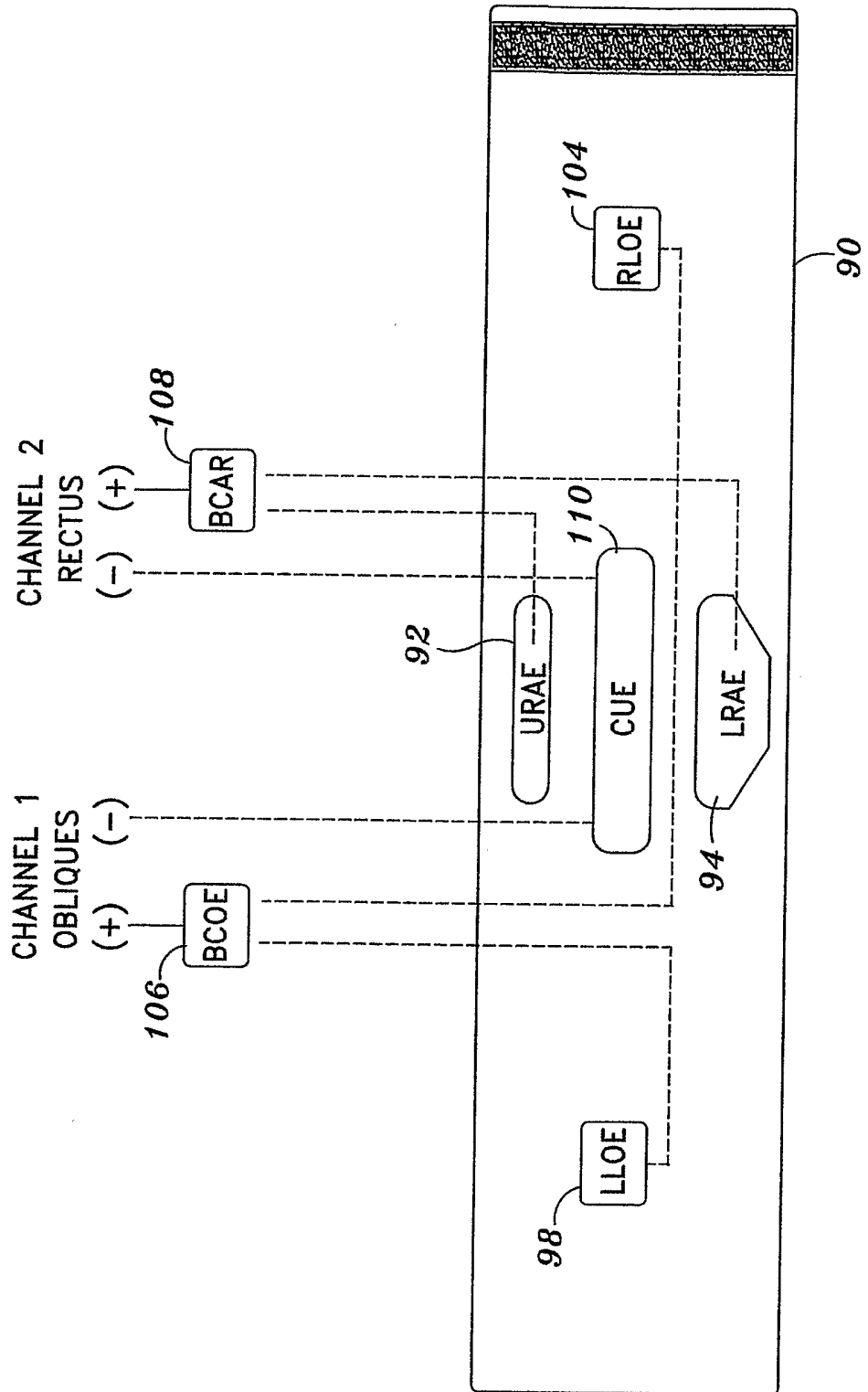
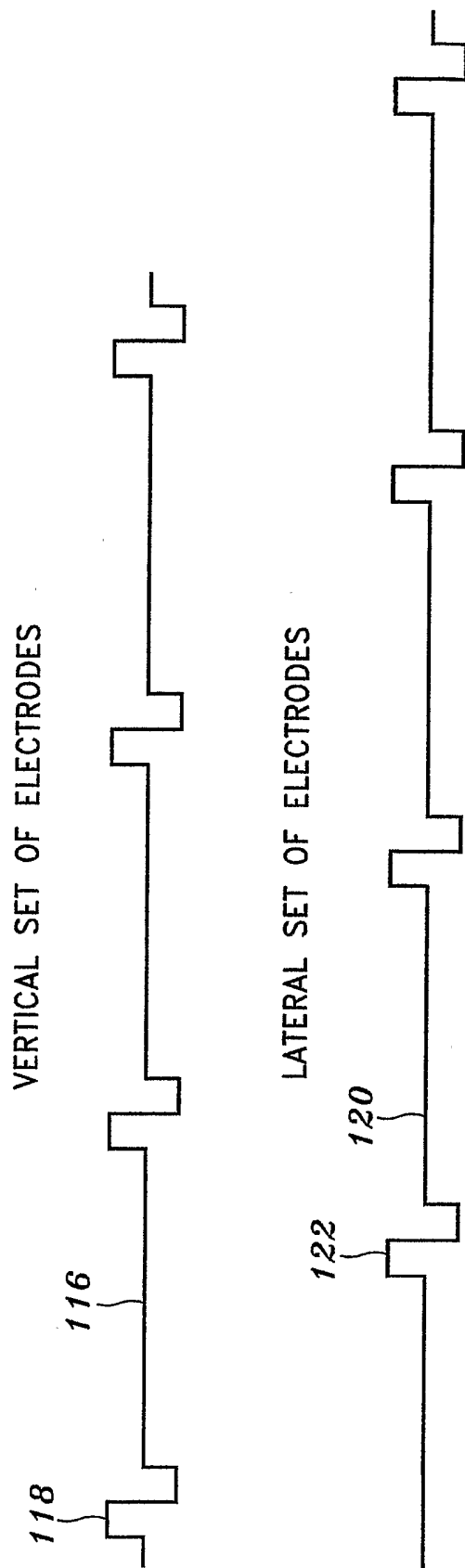

Fig. 3



BIPHASIC SYMMETRICAL WAVEFORM

Fig. 4

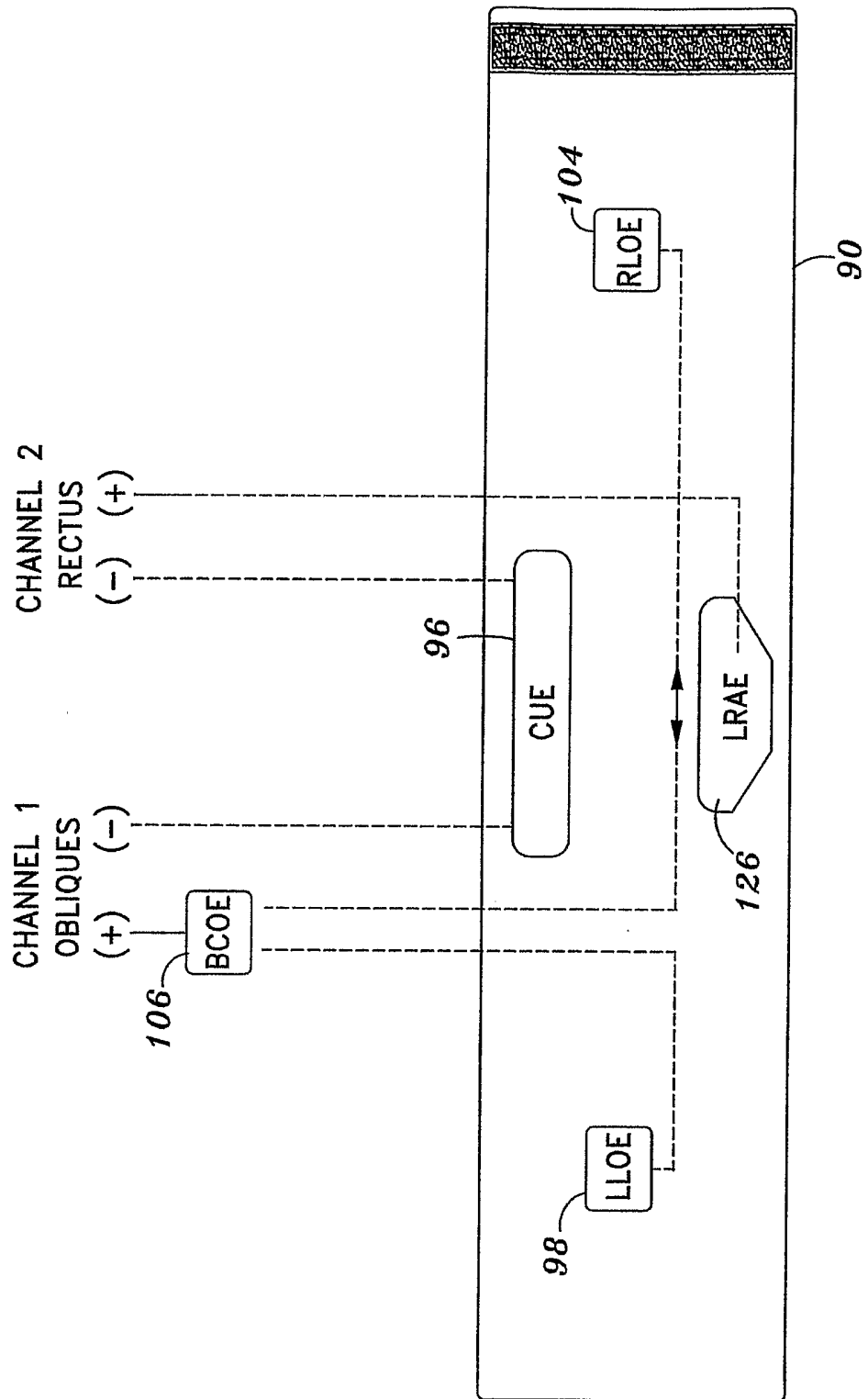

Fig. 5

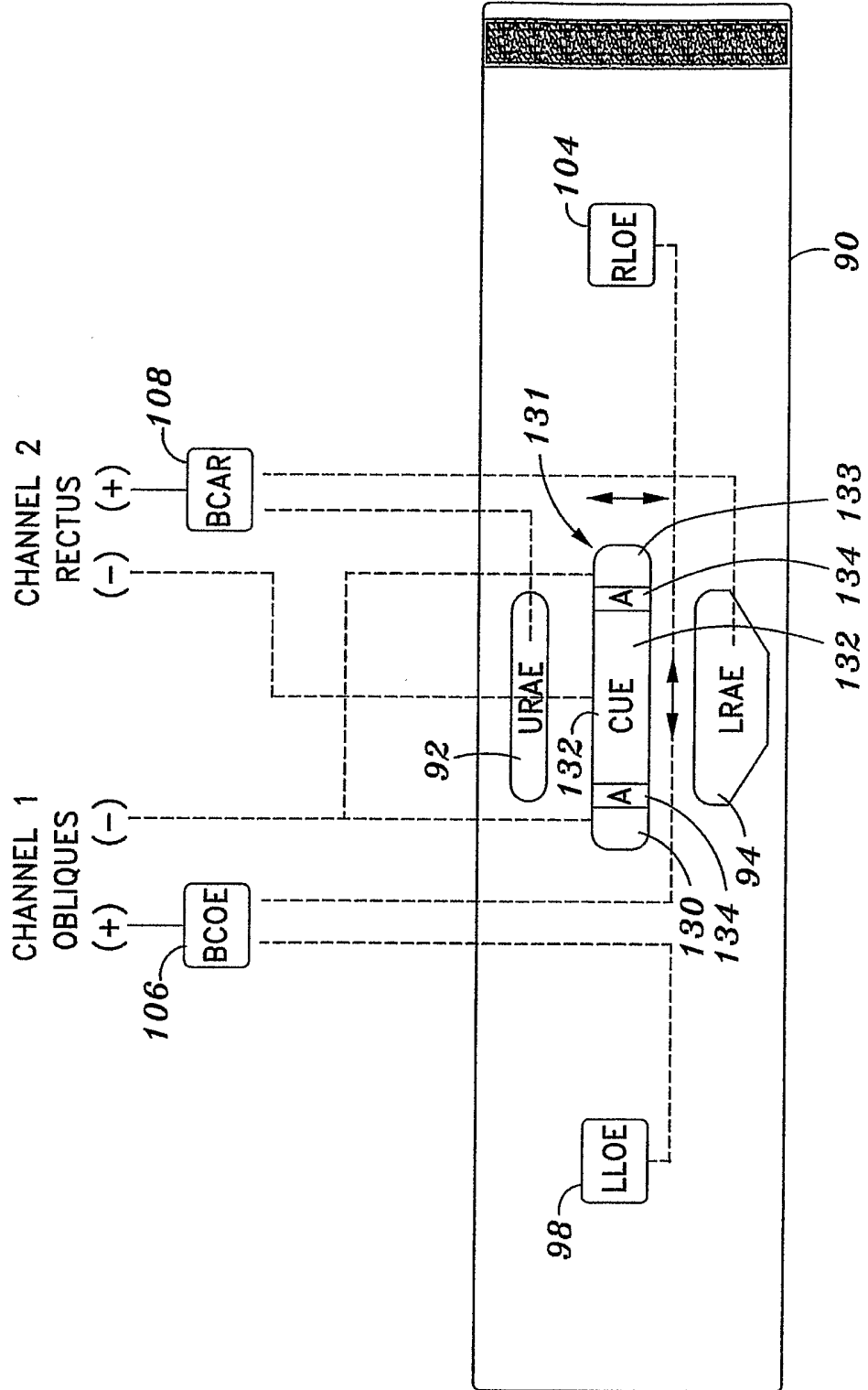

Fig. 6

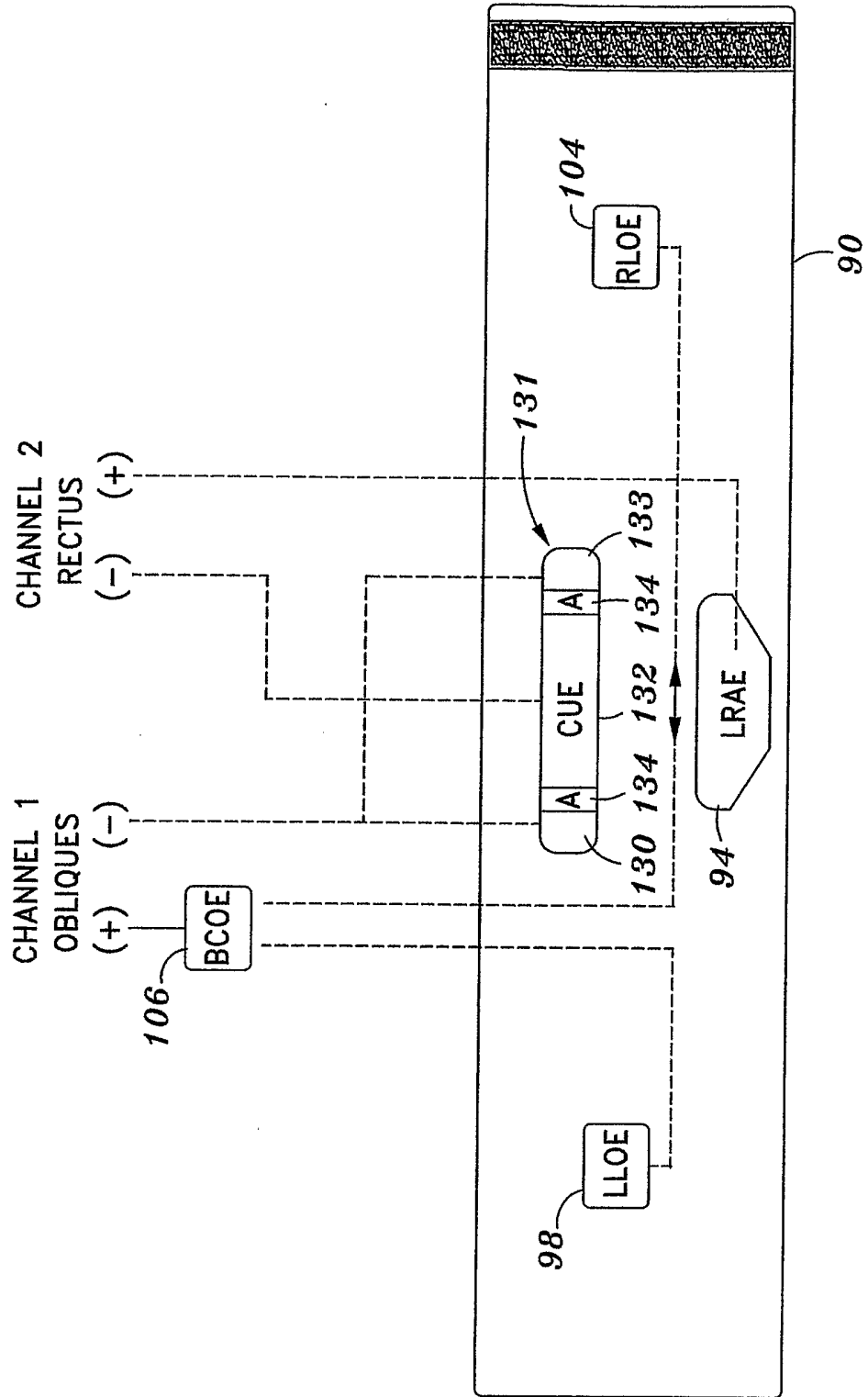

Fig. 7

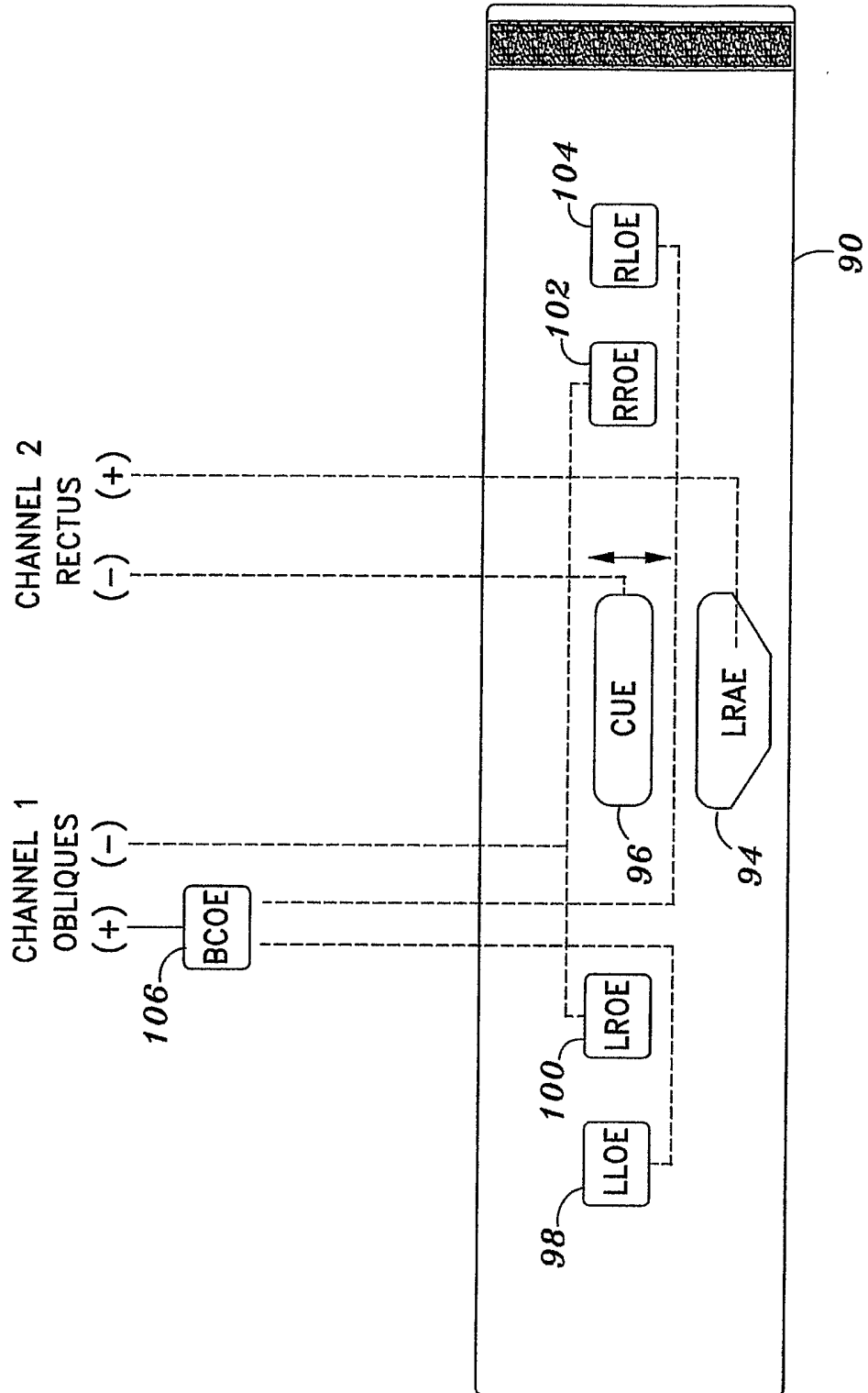

Fig. 8

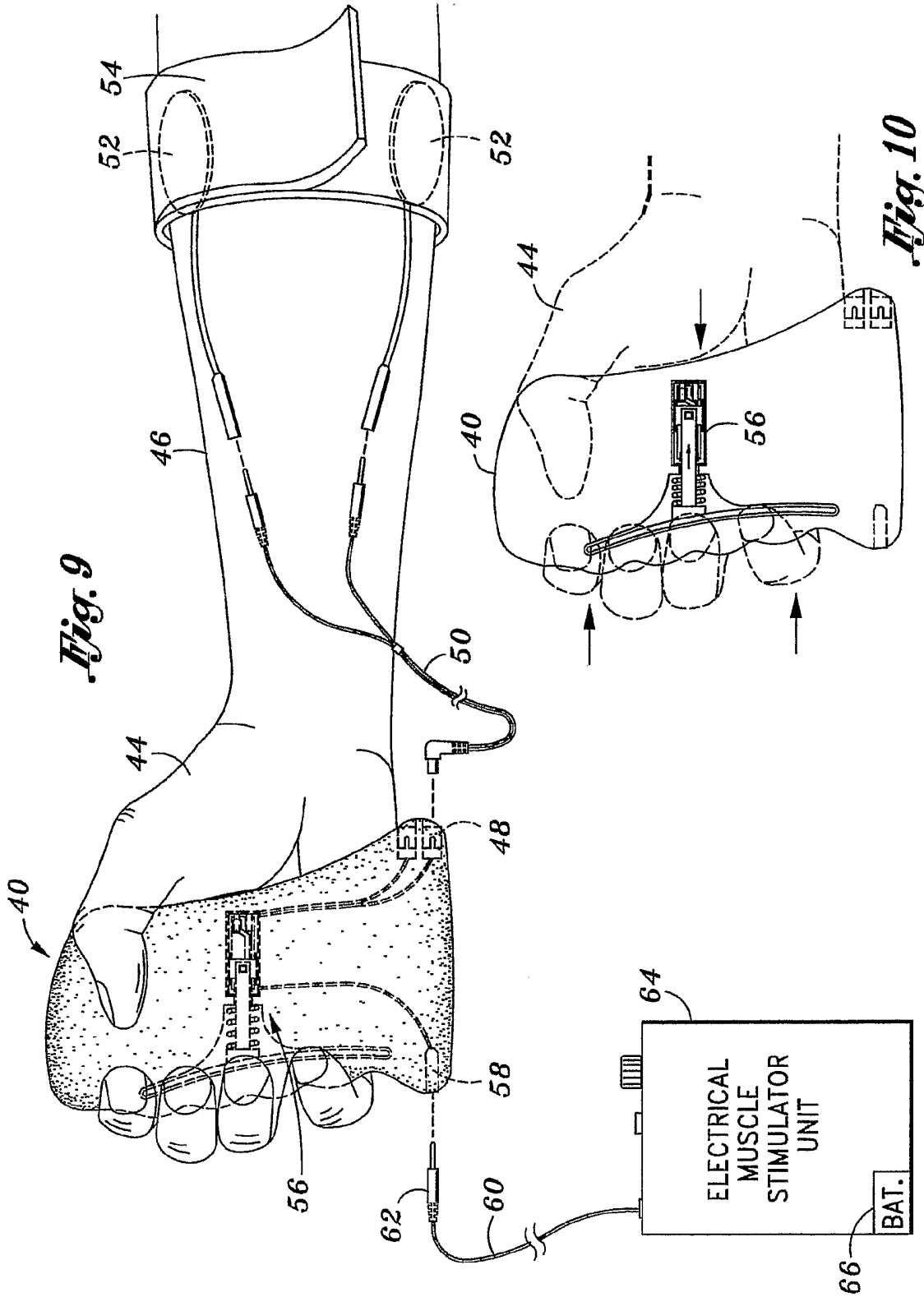

Fig. 9

Fig. 10

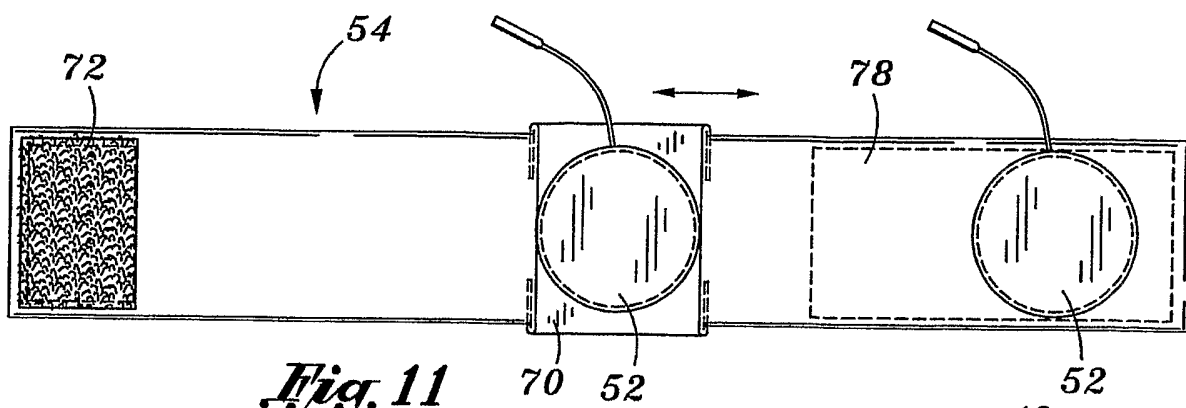

Fig. 11

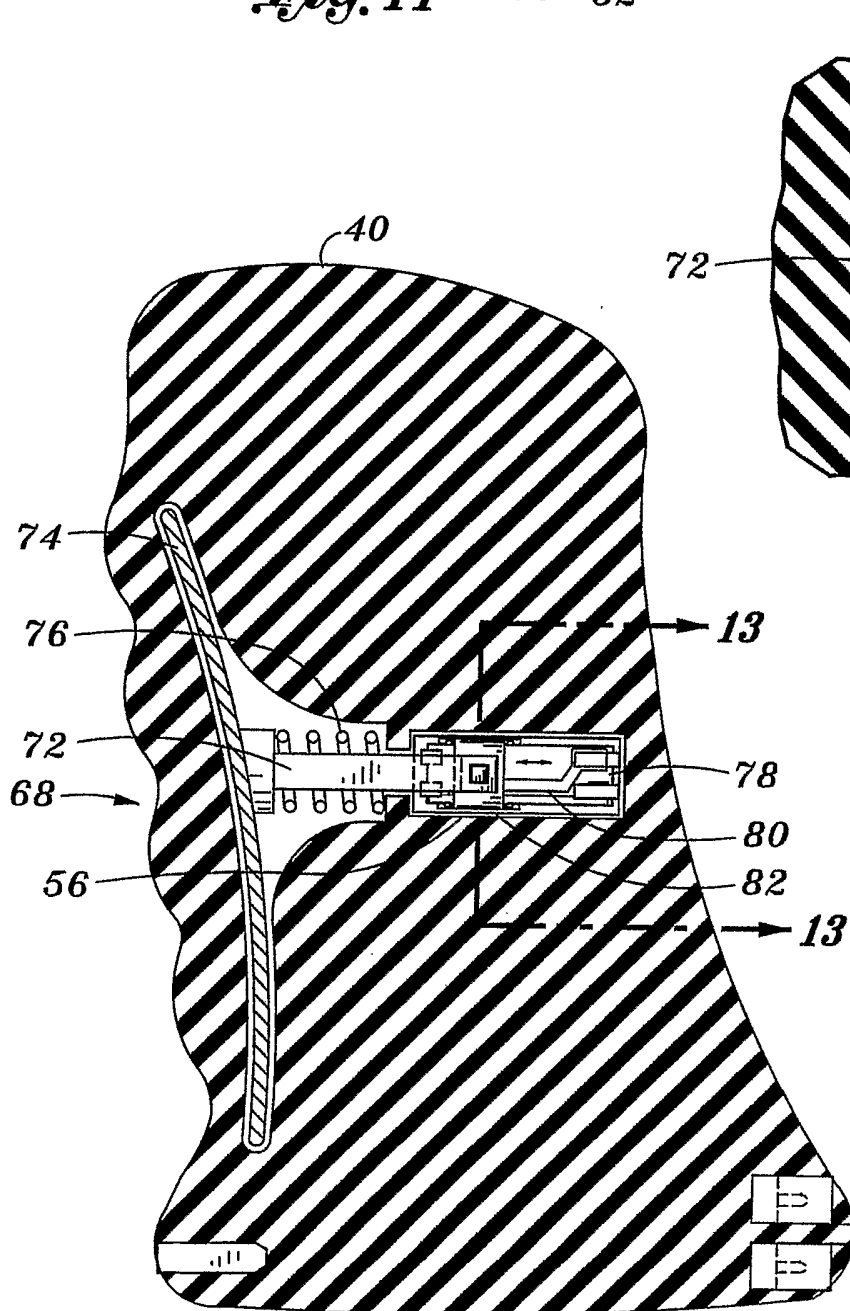

Fig. 12

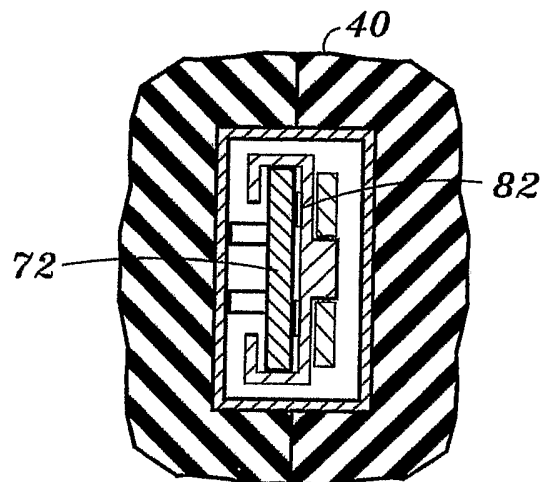

Fig. 13

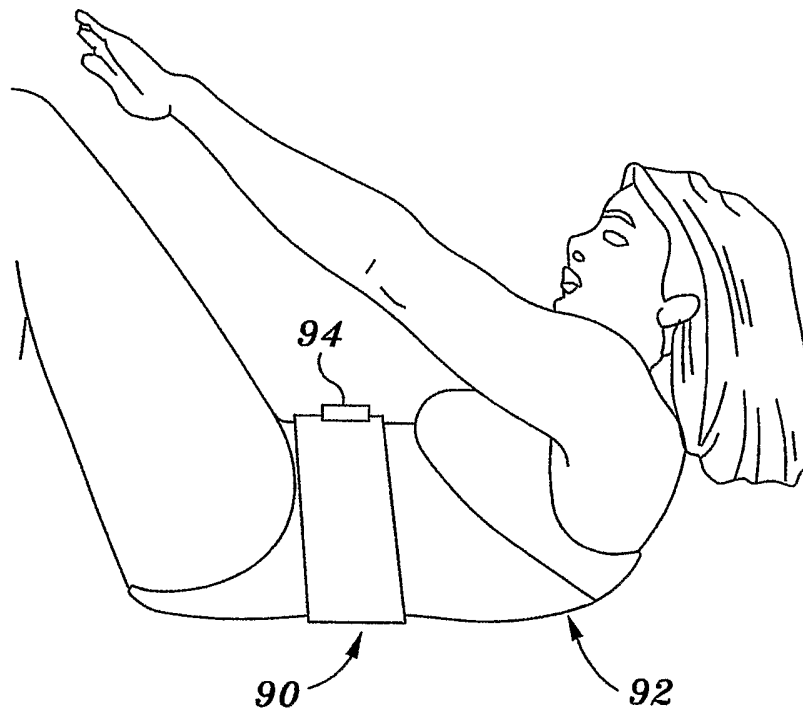

Fig. 14

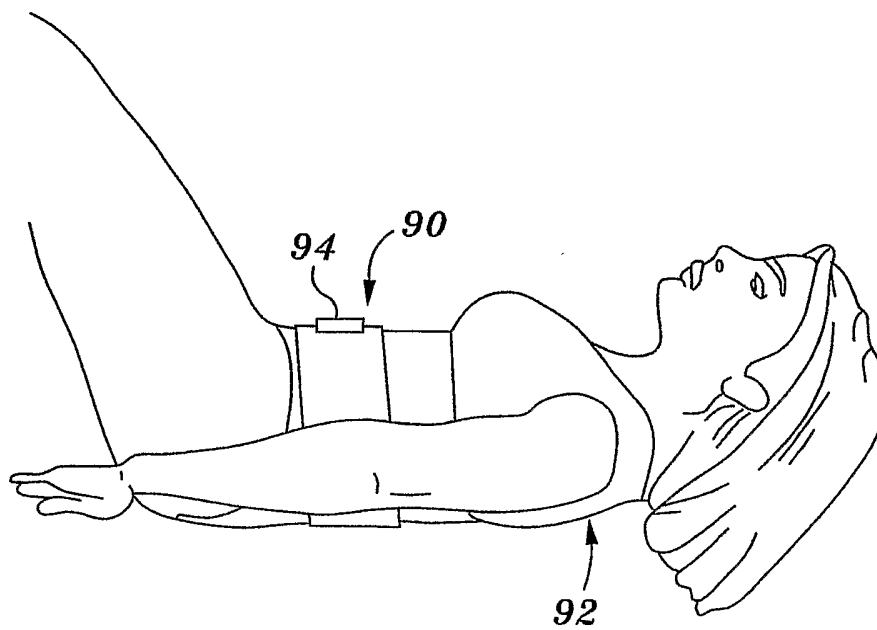

Fig. 15

Fig. 16

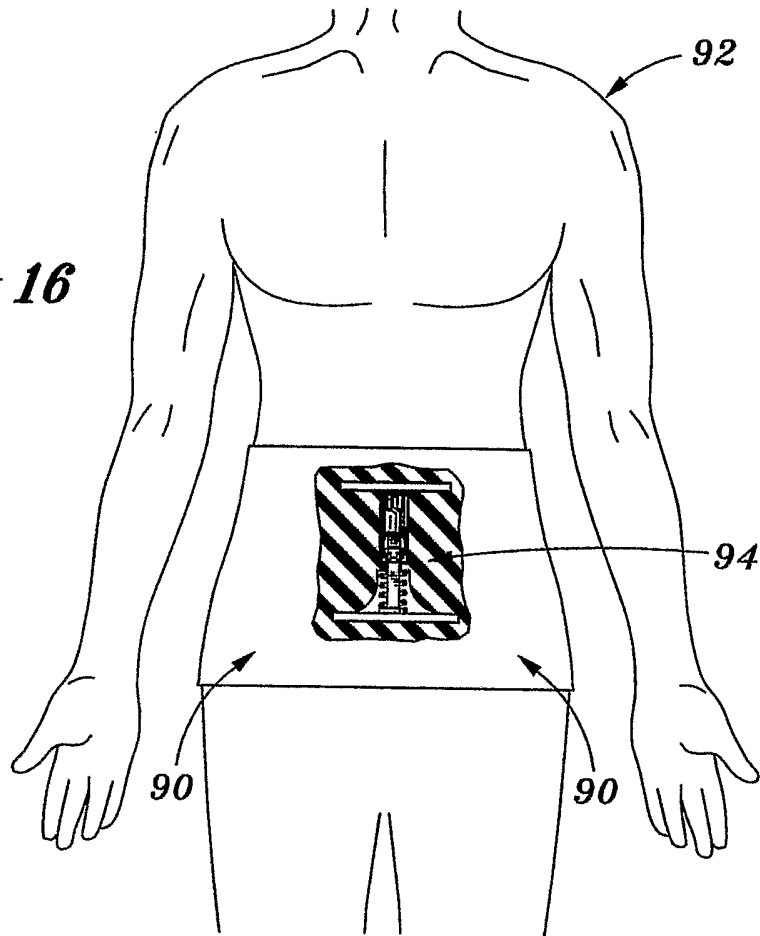
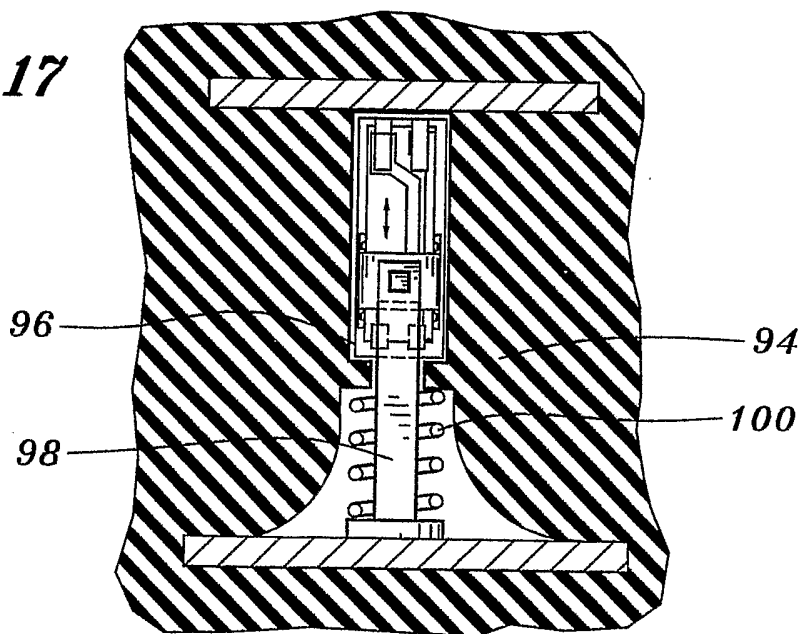

Fig. 17



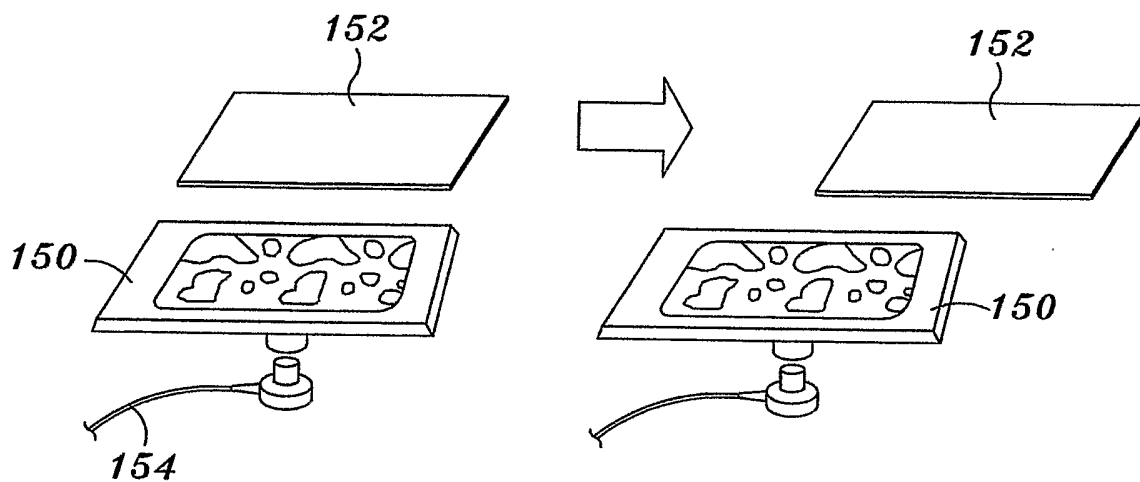

Fig. 18

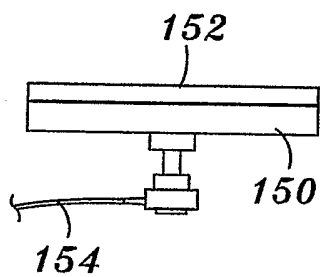

Fig. 19A

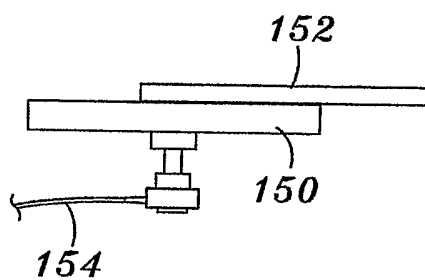

Fig. 19B