



(12) **EUROPEAN PATENT APPLICATION**

(43) Date of publication:
08.09.1999 Bulletin 1999/36

(51) Int Cl. 6: **E05D 15/06, E05D 5/02**

(21) Application number: **99500037.9**

(22) Date of filing: **05.03.1999**

(84) Designated Contracting States:
**AT BE CH CY DE DK ES FI FR GB GR IE IT LI LU
MC NL PT SE**
Designated Extension States:
AL LT LV MK RO SI

(72) Inventor: **Tarrega Lloret, Miguel Angel
08017 Barcelona (ES)**

(74) Representative: **Davila Baz, Angel
c/o Clarke, Modet & Co.,
Avda. de los Encuartes 21
28760 Tres Cantos (Madrid) (ES)**

(30) Priority: **06.03.1998 ES 9800483**

(71) Applicant: **KLEIN IBERICA, S.A.
E-08024 Barcelona (ES)**

(54) **Mounting mechanism for sliding glass doors**

(57) Mechanism for mounting sliding glass doors, consisting of an upper rail (3-4), lower guides (5-6) and suspension heads (7-8) attachable to the upper edge of the door (1-2) and having rolling elements (9-10) which can move along the upper rail. The suspension heads are made from two baseplates which are connected to

each other and to the door and which have on their inner face from the upper edge corresponding matching indentations with a longitudinal channel or groove (19) which define guides between which is mounted a baseplate (20) with an orifice for a screw (22) which attaches it to the rolling elements (19).

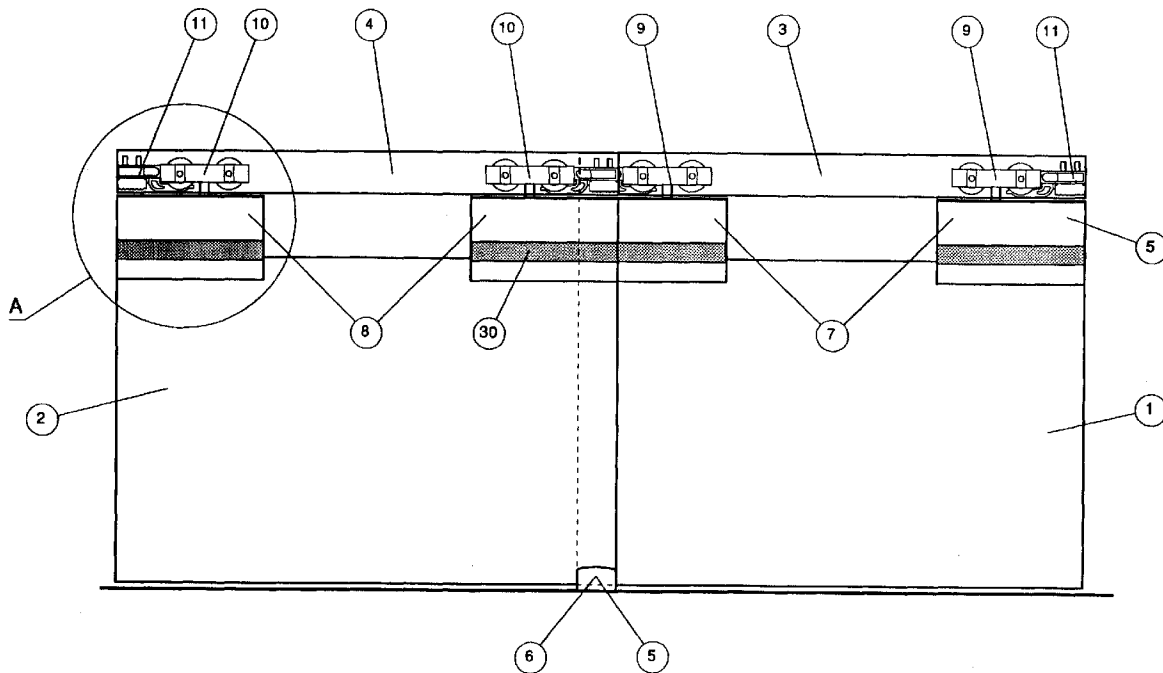
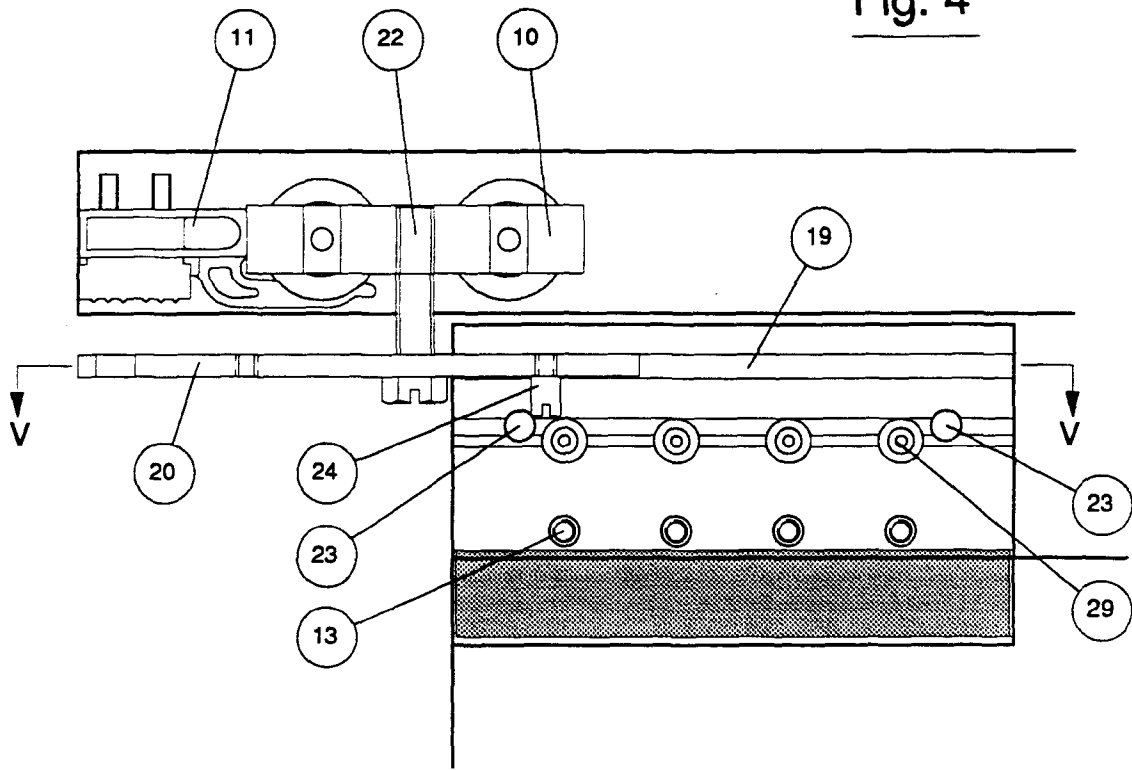

Fig. 1

Fig. 4



Description

[0001] The present invention refers to a mounting mechanism for sliding glass doors which does not require machining operations on the glass leaves and in addition allows an exact regulation of the height position.

[0002] More specifically, the mechanism of the invention is of the type which comprises an upper rail, a lower guide parallel to the upper rail and suspension heads which are attached to the upper edge of the door and have rolling elements which can move along the upper rail.

[0003] The Spanish patent application no. 9300632 already informs of a mechanism of the type described, in which the suspension heads are composed of two back-to-back plates which can be attached to each other in a matching position, which on their opposing faces and from the lower edge have matching indentations which make up a lower recess which can be attached to the upper edge of the door. One of the plates which make up the suspension head has one or more free wheels mounted on its outer face. The upper rail, on the other hand, is composed of an L-shaped bar with a horizontal branch which defines the track on which rest and may move the wheels of the suspension head.

[0004] With the arrangement described it is not possible to mount parallel leaves close to each other as they must be separated at least by the distance required to house the parallel rails of the different leaves.

[0005] For this same reason, mechanisms of the type described do not allow mounting glass doors between walls, when the wall separation is smaller than the width required to attach the bar which makes up the upper rail plus the space required for the door.

[0006] A further inconvenience of the mechanisms described is the difficulty of adjusting the door height, which is determined by the position of the rail.

[0007] For wooden sliding doors mechanisms are known in which the upper rail consists of a tubular bar above the door and open longitudinally on its lower side. Inside this rail carriages may move which are connected to the door leaves by vertical screws anchored on their lower side to a mounting element which is embedded and attached to the door, on its upper edge. In this sense the Spanish patent application no. 9501409 of the same applicants may be mentioned. Although this mechanism allows placing the parallel leaves very close to each other, it is not applicable to glass doors as it is not possible to embed and attach the mounting element to the upper edge of the leaves.

[0008] The object of the present invention is to eliminate the problems described by a mechanism of the type initially mentioned and which presents specific characteristics allowing mounting of one or more leaves in a small space, enough to house the leaves with their corresponding suspension heads.

[0009] Another object of the invention is being able to

adjust the height of the leave or leaves of the door, absorbing even certain tolerances or variations in the exact position of the upper rail and lower guide.

[0010] As mentioned above, the mechanism of the invention includes an upper rail and a lower guide between which are mounted the leave or leaves of the door and the suspension heads attachable to the upper edge of the door consisting of two back-to-back plates attachable to each other in a matching position.

[0011] According to the invention, the plates which make up the suspension heads have, on their inner face and after their upper edge, respective matching longitudinal indentations which make up an upper recess when the plates are placed together. These indentations which make up the recess have in their turn an equal number of identical grooves or channels along their bottom which face each other and define longitudinal guides in the recess, between which is mounted, so that it may move longitudinally, a baseplate with an orifice through which a mounting screw passes to a carriage which is placed above the door and which may travel along the inside of the upper rail.

[0012] In the mechanism of the invention the upper rail is composed of a tubular bar which is open on its lower side. The carriage or carriages joined to the suspension heads by the aforementioned mounting screw can travel along the inside of this bar.

[0013] With this arrangement glass doors of two or more parallel leaves near each other may be mounted with sufficient room for the width of the suspension heads as the upper rail is above the leaves, as are the rolling elements.

[0014] The upper recess of the suspension heads described, as well as the baseplates have means to limit the displacement of the baseplate once it is mounted on the recess guides between a position of maximum extraction in which the orifice for the screw to the carriage is left beyond the suspension head and an inner position in which the baseplate is completely housed in the recess. The suspension heads also have means to block the baseplate in its inner limit position, remaining locked there with no danger of accidental displacement when the door leaves are moved.

[0015] The arrangement described also has the advantage of allowing adjusting the height of the leaves by the baseplate to carriage mounting screw, an operation which will be executed when the baseplate is in the position of maximum extraction. Once the height is adjusted the baseplate is moved to its inner position and locked.

[0016] The upper recess of the suspension heads will have a width matching the head of the carriage mounting screw so that when the baseplate is moved to the inner position where the head of the screw is inside the recess, the screw cannot turn and accidentally loosen.

[0017] The characteristics set forth as well as others characteristic of the invention are presently described in greater detail with the aid of the attached drawings

where an example is shown of an embodiment of a non-limiting nature.

[0018] In the drawings:

[0019] Figure 1 is a front elevation of a mechanism in agreement with the invention for mounting two glass sliding doors with a cross section of the upper rail to show the movable carriages.

[0020] Figure 2 shows enlargement A of figure 1, at a greater scale and in cross section.

[0021] Figure 3a is a cross section of the suspension head along the III-III line of figure 2.

[0022] Figure 3b is a view similar to figure 3a with a variation of execution.

[0023] Figure 4 is a view similar to figure 2 with the baseplate to which is attached the mounting screw out of the suspension head.

[0024] Figure 5a is a longitudinal cross section of the suspension head along the line V-V of figure.

[0025] Figure 5b is a view similar to figure 5a showing a variation of execution.

[0026] Figure 6 shows a cross section of the suspension heads, upper rail and lower guide corresponding to the two leaves of the glass door.

[0027] The door shown in figure 1 includes two glass leaves labeled 1 and 2, which are mounted by a mechanism which includes an upper rail for each door, labeled by numbers 3 and 4, and lower guides 5 and 6. Each of the doors has suspension heads mounted on top labeled 7 and 8. Upper rails 3 and 4 as seen in figure 6, are tubular in section and are open along the bottom side. Inside each rail carriages 9 and 10 are housed, connected to suspension heads 7 and 8 as described below.

[0028] On the ends of rails 3 and 4 are extreme stops 11 which limit the displacement of carriages 9 and 10 and define their position when the doors 1 and 2 are closed.

[0029] As can be seen in figures 2 and 6, each of suspension heads 7 and 8 is composed of two rectangular plates 12, back-to-back and joined by screws 13. These plates have, on their inner face and from the lower edge, longitudinal indentations which define as the plates are joined a recess 15 which is connected to the upper edge of glass leaves 1 and 2. The inner surface of indentations 14 can be covered in a shock-absorbing and anti-skid material.

[0030] Plates 12 also have on their inner surface and from the upper edge corresponding longitudinal indentations 17 which define as the plates are set, a longitudinal recess 18. Indentations 17 have identical grooves or channels 19 on the bottom, which are left facing each other and define in recesses 18 longitudinal guides between which is mounted a baseplate 20 which can move horizontally.

[0031] This baseplate, as seen in figures 3 and 5, has an orifice 21 through which screw 22 passes attaching it to the corresponding suspension carriage.

[0032] Suspension heads have means in order to limit

the displacement of baseplate 20. These means can consist of pins or bolts 23 mounted across plates 12, which are tangent to recess 18 and slightly project out from the bottom. These means complement screws 24 which are attached to baseplate 20 and which project from the bottom and act as limiting stops for the displacement of the baseplate as they collide with pins 23. In the position shown in figure 2, baseplate 20 is housed completely inside recess 18 defined by plates 12, with screw 24 resting on one pin 23. In the position shown in figure 4, plate 20 is in the position of maximum extraction, screw 24 colliding with the other pin 23. In the position of figure 4 orifice 21 of baseplate 20 is outside recess 18 allowing the introduction of mounting screw 22 to the carriage 10, at which position the head of screw 22 can be acted upon to adjust the height of baseplate 20 and thus that of suspension heads 7 and 8, and therefore that of glass leaves 1 and 2, figure 1.

[0033] In the inner position of baseplate 20, shown in figures 2 and 3a, this position is locked by locking elements consisting of a pressure screw 25 inserted through a threaded orifice in one of plates 12 level with channel 19. Baseplate 20 has notches 26 in its longitudinal edges which lie opposite screw 25 in its inner position, as shown in figure 3. By tightening screw 25 it partially enters notches 26, stopping baseplate 20 from moving and perhaps projecting out from the suspension head accidentally, for example due to the displacement of the door leaves.

[0034] According to a variation of execution shown in figures 3b and 5b, baseplate 20 has a striation or groove 28, for example in its upper surface, which creates sufficient friction with channels 19 to prevent its accidental displacement.

[0035] As shown in figure 6, upper recess 18 of the suspension heads 7 and 8 is of the same width as the head of screw 22, at least in the segment located under channels 19. In this way screw 22 cannot turn once baseplate 20 is in its inner position of figures 2 and 3. Above channels 19 upper recess 18 can be of lesser width, enough to allow the pin of screw 22 to pass.

[0036] Plates 12 which make up the suspension head have, along their upper and outer edges, grooves or channels 27 meant for attaching brushes which close against tubes 3 and 4 which make up the upper rails.

[0037] In figure 6 heads 7 and 8 are shown in different cross sections in order to show in one case screw 13 for mounting of the two head plates and in the other case screw 22 for attaching the head to the corresponding carriage.

[0038] With the arrangement described and as seen in figure 6, parallel leaves of a glass door may be placed near each other, as corresponding suspension rails 3 and 4 are left above these leaves, back-to-back and it is enough that space remains between consecutive leaves to house suspension heads 7 and 8.

[0039] For this same reason a single-leaf door could be mounted between two walls which are near each oth-

er as long as upper rail 3 and the door suspension head can be housed.

[0040] In addition, as mentioned above screw 22 allows to adjust the height of the suspension head and with it that of the corresponding glass leaf.

[0041] Between plates 12 which make up the suspension heads are placed spacers 29, figures 2, 4 and 6, the length of which is adjusted for different thicknesses of glass leaf 1 or 2, for example for two different widths. In this case there are also two baseplates 20 of different width for mounting between channels 19.

[0042] The heads of screws for attaching plates 12 of each suspension head can be hidden by decorative strips 30, figure 6, or coupled to a slight groove of said plates on their outside face, level with the passage orifices of these screws.

[0043] Although in the example described each glass leaf 1 or 2 has two suspension heads 7 - 8, a single head of length equal to the width of the leaf could be used, with the above described components on its ends.

Claims

1. Mechanism for mounting sliding glass doors, comprising an upper rail (3, 4), a lower guide (5, 6) parallel to upper rail (3, 4) and suspension heads (7, 8) which may be attached to the upper edge of the door (1, 2), and having rolling elements which can move along the upper rail, with suspension heads (7, 8) composed of two back-to-back baseplates (12) which can be attached to each other so that they match and have on their matching faces and from the lower edge, corresponding matching indentations (14) which define a lower recess which can be mounted on the upper edge of the door, characterised in that the plates which make up suspension heads (7, 8) have on their inner face from the upper edge corresponding matching longitudinal indentations (17) which define as said plates (12) are set next to each other an upper recess (18); said indentations (17) have an equal number of identical grooves or channels (19) along their bottom, which are left opposite each other and form in the recess longitudinal guides between which is mounted, so that it may slide, a baseplate 20 with an orifice (21) through which passes a screw (22) for attachment to a carriage placed above door (1, 2) and which may move on the upper rail (3, 4); said upper recess (18) and baseplate (20) have means to limit the displacement of baseplate (20) between a position of maximum extraction, in which orifice (21) for screw (22) of attachment to the carriage is left outside the recess (18), and an inner position in which baseplate (20) is completely housed in the recess (18), also having means to lock the baseplate in its inner position.
2. Mechanism as in claim 1, characterised in that the upper recess (18) is of an equal width to the head of the screw (22) for attaching to the carriage, at least in the segment placed below the aforementioned longitudinal guides (26) while above these guides (26) it is preferably of lesser width, enough to allow passage of the pin of suspension screw (22).
3. Mechanism as in claim 1, characterised in that the means which limit the displacement of baseplate (20) consist of two pins or bolts (23) which cross the suspension head (7, 8) near its side edges and in a position secant to the upper recess (18), and of a lower stop of the baseplate (20) which touches said bolts (23) when baseplate (20) reaches its limit positions.
4. Mechanism as in claim 1, characterised in that the means for locking baseplate (20) in its inner position consist of at least one pressure screw (25) screwed into one of the plates (12) which make up suspension heads (7, 8) in a position matching the internal groove or channel, and of an indentation which baseplate (20) has in its longitudinal edges in a position even with the pressure screw (25) as said baseplate (20) reaches its inner position.
5. Mechanism as in claim 1, characterised in that the means for blocking the baseplate in its inner position consist of a striation or groove (28) formed on one of the surfaces of said baseplate (20) along the areas which rest on and rub on the channels or grooves of plates (12) of the suspension heads.

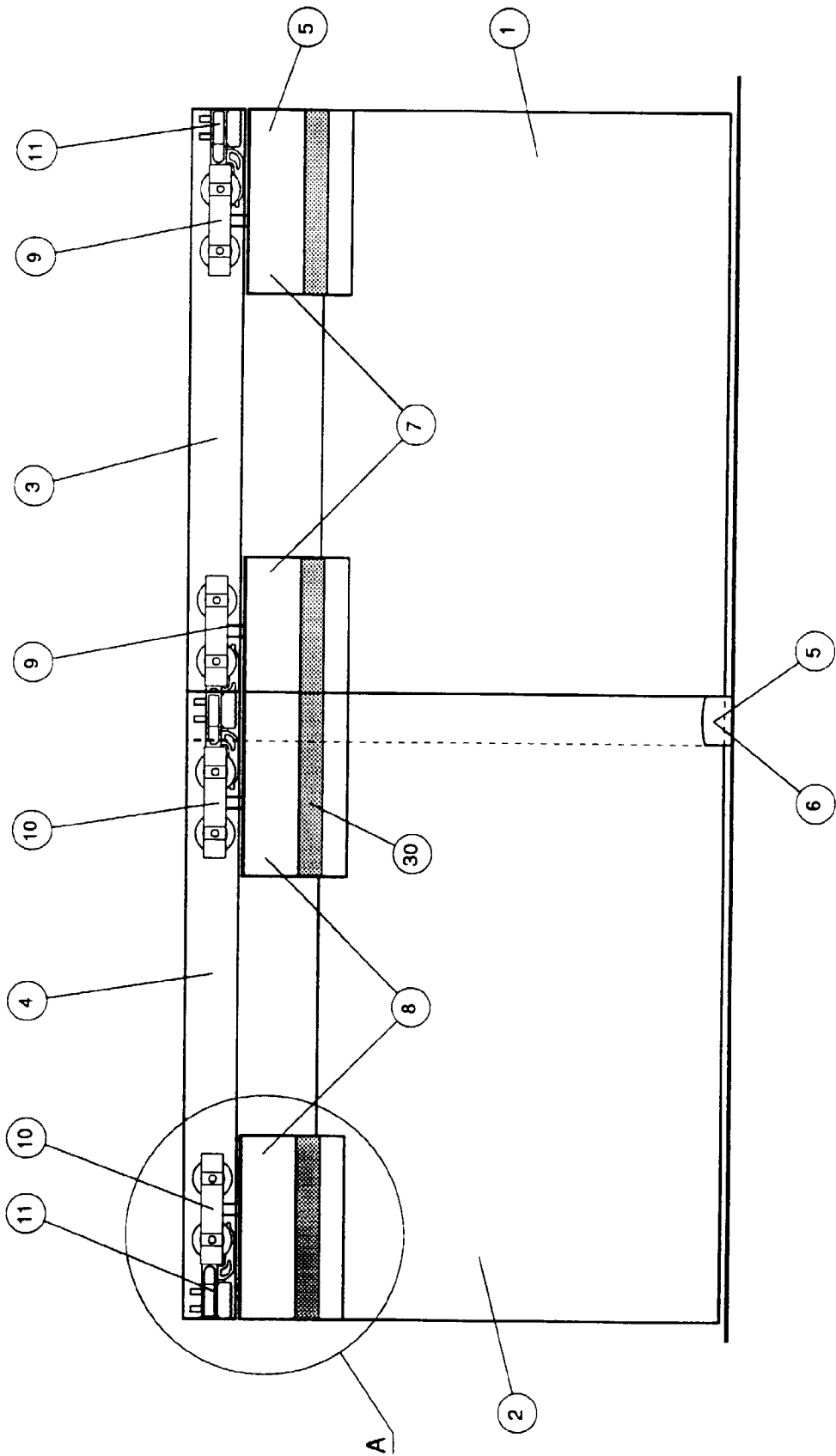

Fig. 1

Fig. 2

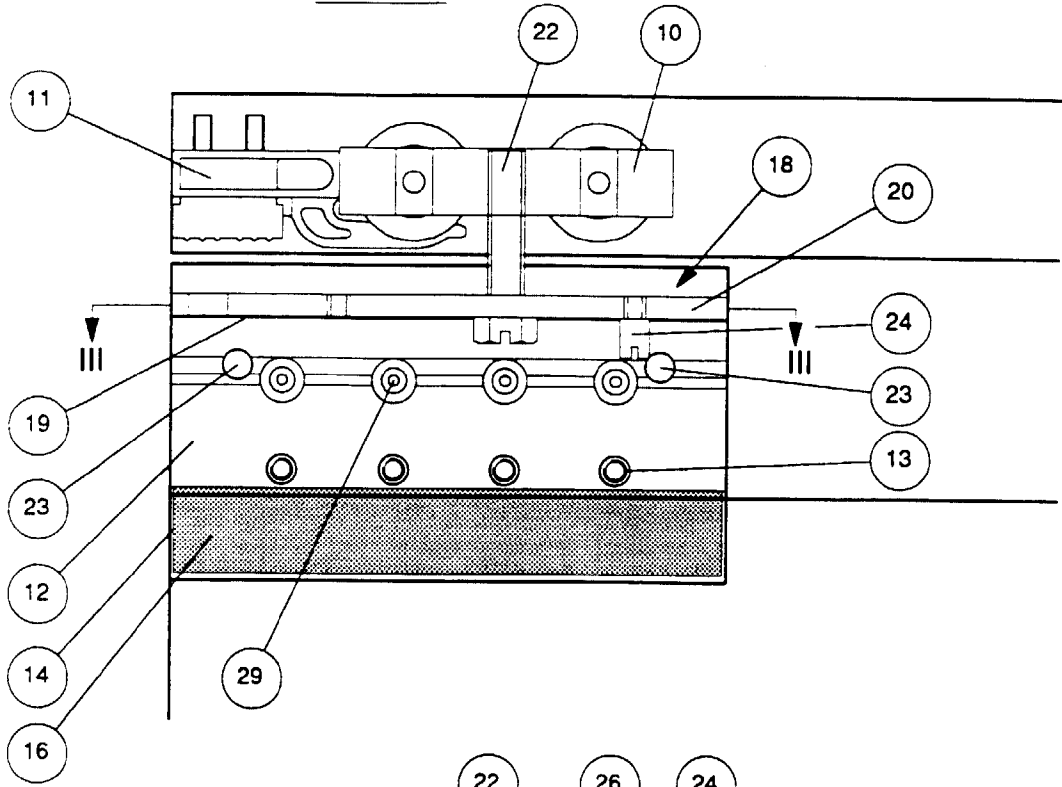

Fig. 3a

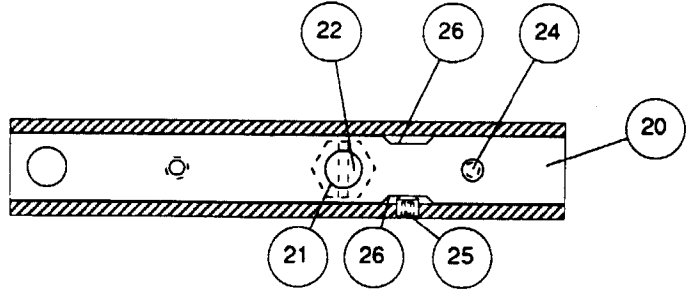

Fig. 3b

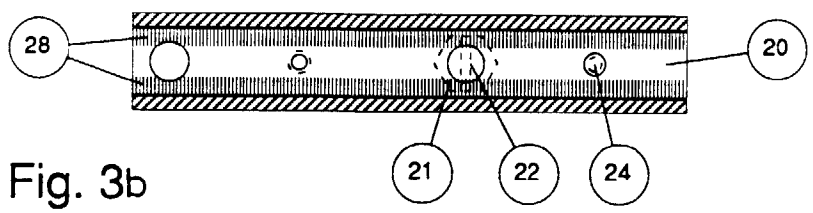

Fig. 4

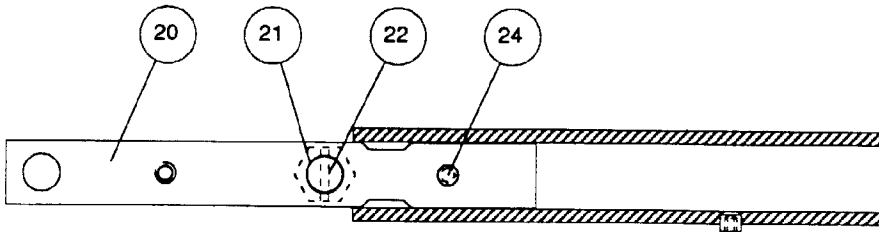
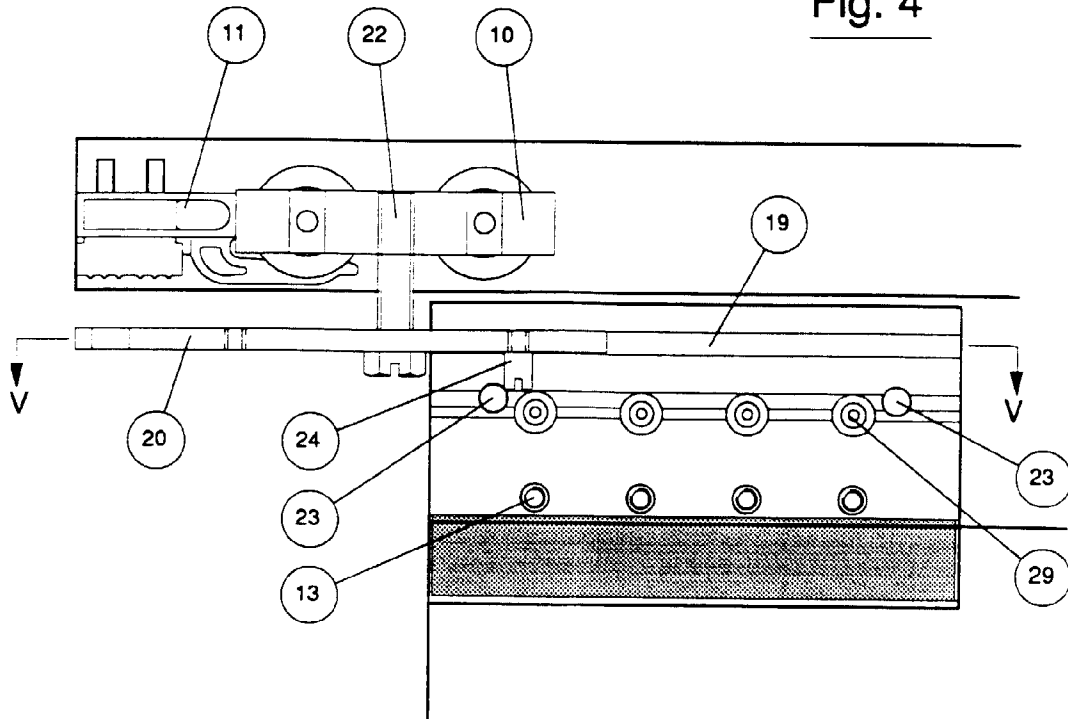

Fig. 5a

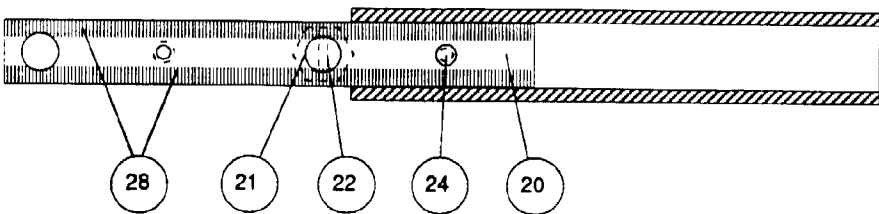

Fig. 5b

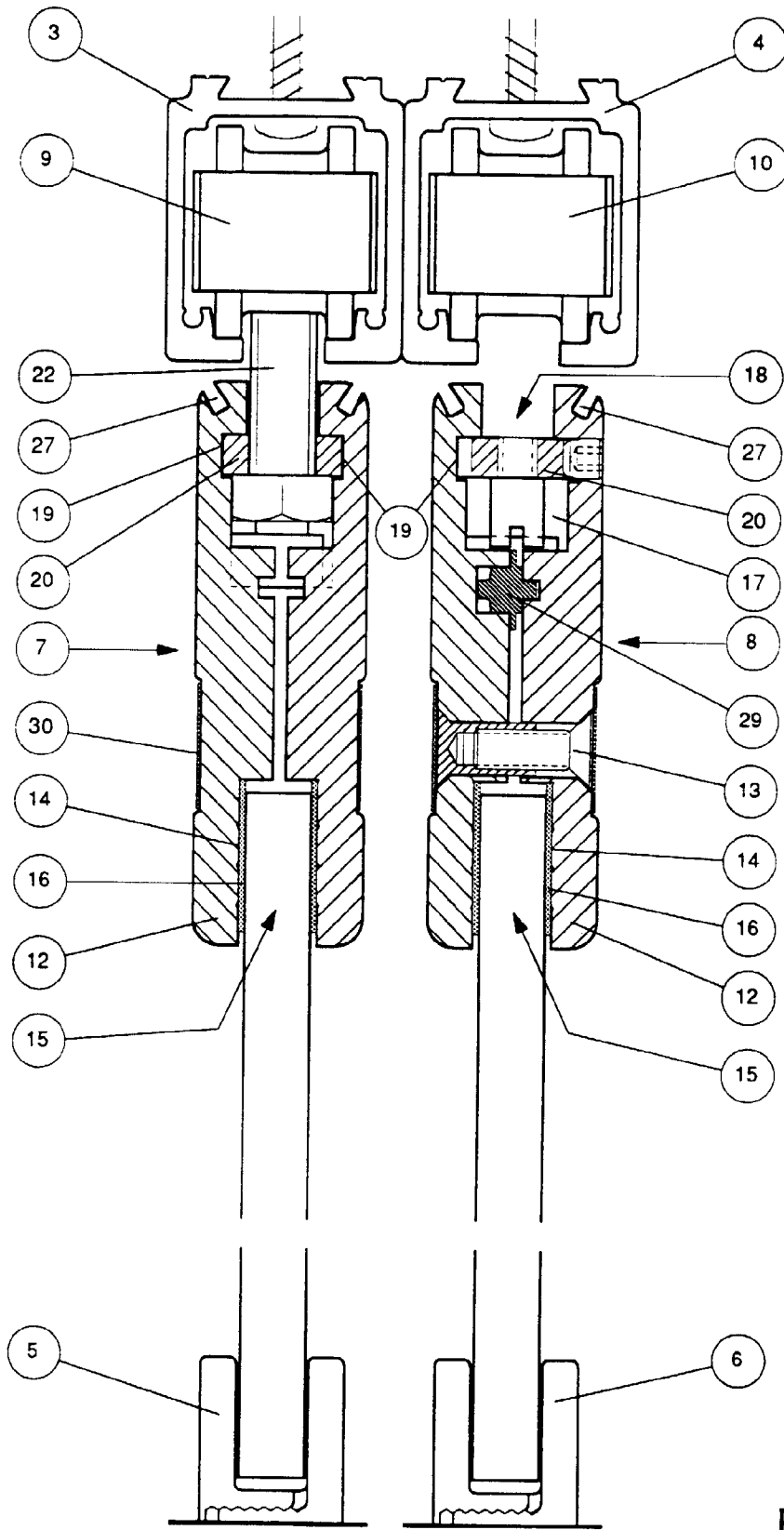

Fig. 6