

- [54] **DIMENSIONALLY STABLE ANODE CONSTRUCTION**
- [75] Inventors: **Richard E. Loftfield**, Chardon; **Ramesh C. Jhaveri**, Mayfield Heights, both of Ohio
- [73] Assignee: **Electronor Corporation**, Panama City, Panama
- [22] Filed: **Oct. 2, 1972**
- [21] Appl. No.: **294,241**

Related U.S. Application Data

- [63] Continuation of Ser. No. 880,797, Nov. 28, 1969, abandoned.
- [52] U.S. Cl. **204/286, 204/290 F, 204/DIG. 7**
- [51] Int. Cl. **B01k 3/04, C01b 7/06, B01k 3/06**
- [58] Field of Search **204/219, 220, 250, 286, 204/288, 290 F**

[56] **References Cited**

UNITED STATES PATENTS

3,042,602	7/1962	De Nora	204/250 X
3,271,289	9/1966	Messner	204/286 X
3,297,561	1/1967	Harrison et al.	204/286
3,308,044	3/1967	Barbato et al.	204/219 X
3,308,047	3/1967	Laub et al.	204/219

3,318,792	5/1967	Cotton et al.	204/219
3,445,374	5/1969	Ishimatsu	204/270
3,458,423	7/1969	Csizi	204/219
3,511,766	5/1970	Kisner et al.	204/279

FOREIGN PATENTS OR APPLICATIONS

1,147,442	4/1969	Great Britain	204/290 F
-----------	--------	---------------------	-----------

Primary Examiner—F. C. Edmundson
 Attorney, Agent, or Firm—Hammond & Littell

[57] **ABSTRACT**

Describes dimensionally stable anodes made of a valve metal (titanium) for electrolytic cells, for the electrolysis of brine solutions and other electrolytes, having lead-in conductors of high conductivity (copper) and inverted U-shaped distributor conductors of valve metal (titanium) extending substantially the length of the anode working face in one direction and of sufficient width and being equally distributed along the anode working face in the other direction to distribute current uniformly over the anode working face, the anode working face being made of valve metal and covered with an electrocatalytic coating capable of catalyzing halogen ion discharge without becoming passivated over long periods of time.

16 Claims, 8 Drawing Figures

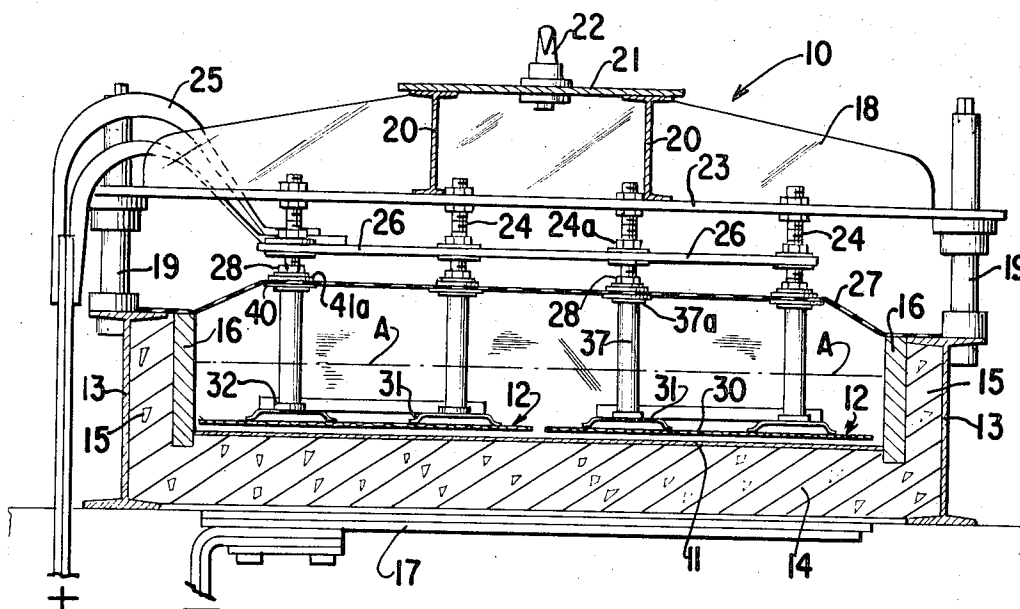

FIG. 1

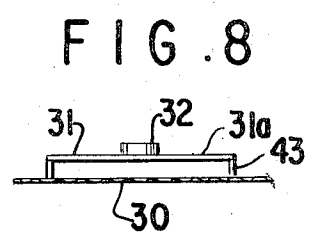
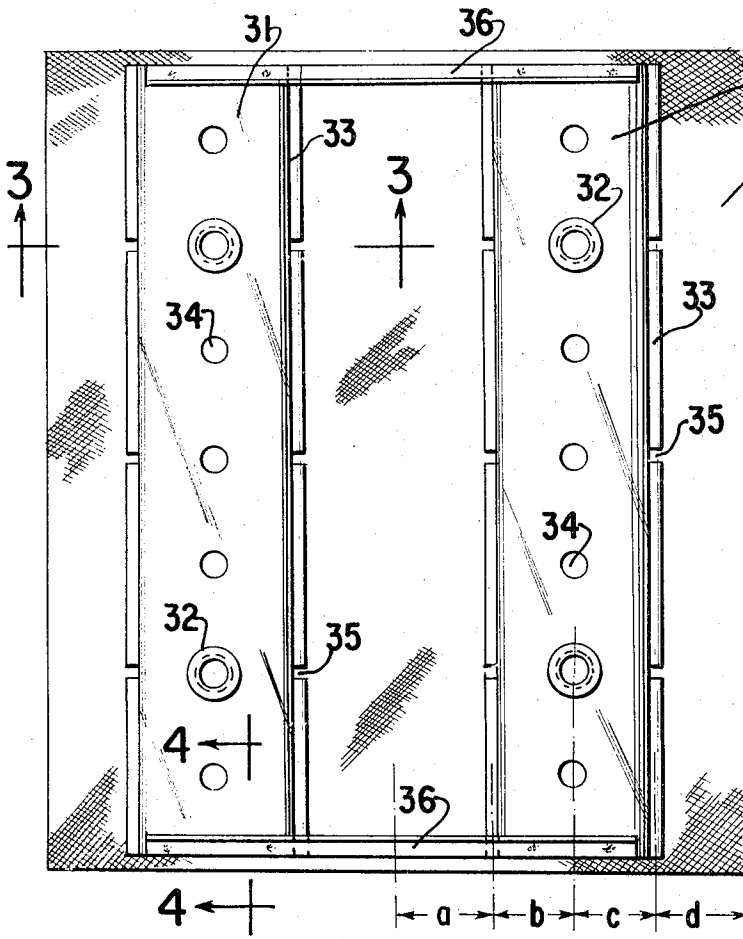
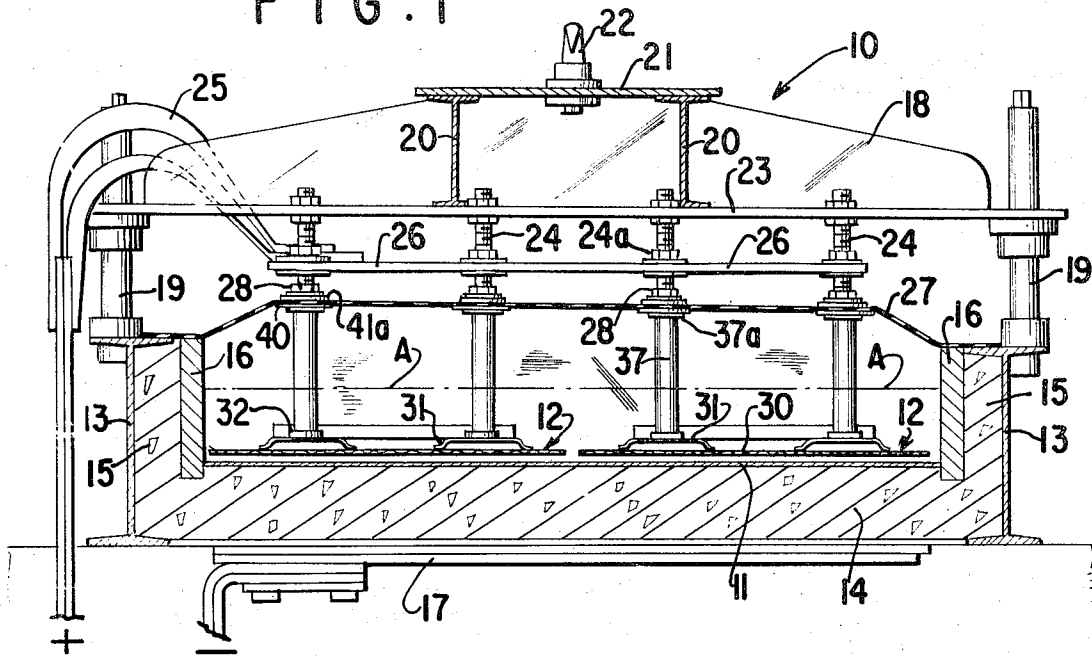

FIG. 2

INVENTORS
RICHARD E. LOFTFIELD
RAMESH C. JHAVERI
BY
ATTORNEYS

FIG. 3

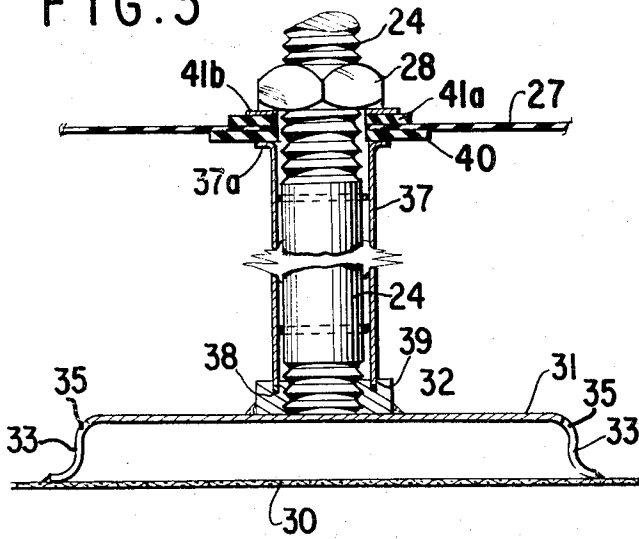

FIG. 4

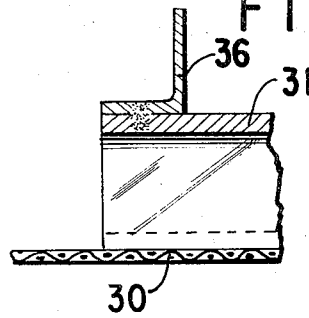

FIG. 6

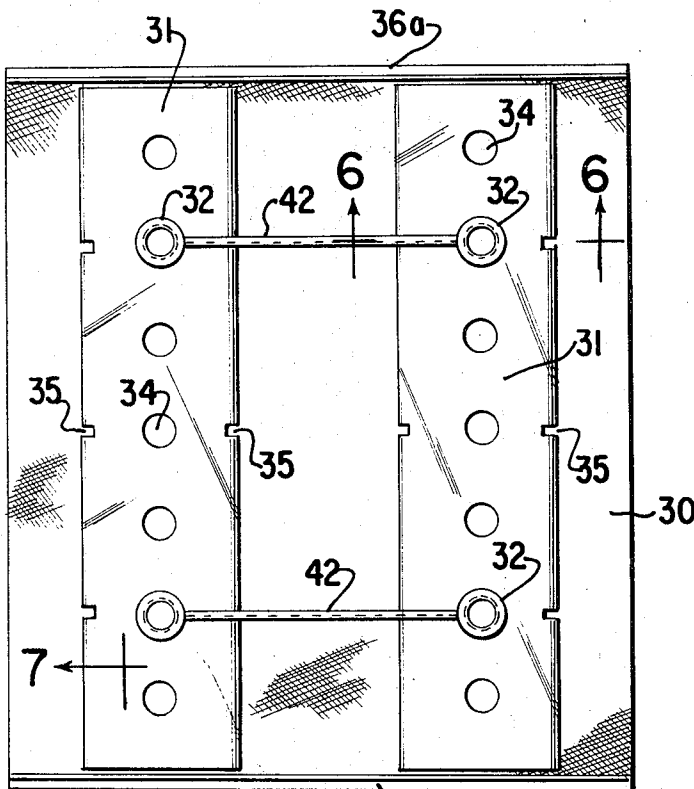
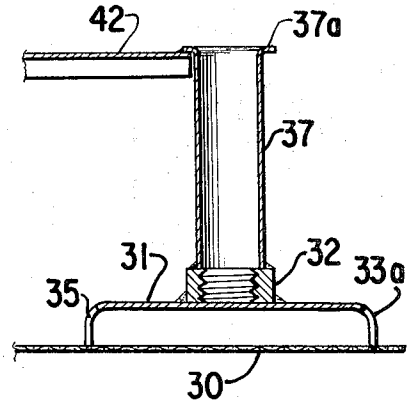
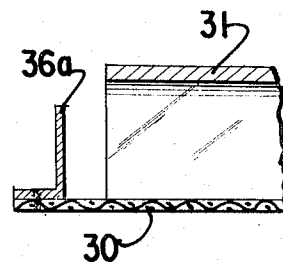

FIG. 5

FIG. 7



INVENTORS
RICHARD E. LOFTFIELD
RAMESH C. JHAVERI
BY *[Signature]*
ATTORNEYS

DIMENSIONALLY STABLE ANODE CONSTRUCTION

This is a continuation of Ser. No. 880,797, filed Nov. 28, 1969, now abandoned.

This invention relates to a new and improved construction of dimensionally stable anodes for use in the electrolysis of alkali metal chlorides and other salt solutions or fused salts, which undergo decomposition under electrolysis conditions.

Dimensionally stable anodes are constructed of metals which are resistant to electrolytic cell conditions, such as valve metals, and have negligible wear and, hence, constant stability of the working surface under normal cell operating conditions. They are used in place of the graphite anodes commonly used in mercury and other electrolysis cells.

The dimensionally stable anodes of this invention will be described, by way of example, for use in the production of chlorine and sodium hydroxide in a flowing mercury cathode electrolysis cell. They can be used in other electrolysis cells and for other purposes.

The dimensionally stable anodes of this invention are preferably constructed of a titanium framework and the titanium anode face is provided with a conductive electrocatalytic coating which protects the titanium anode face from developing a passivating film and continues to conduct electrolysis current from the face of the anode to the electrolyte and to catalyze chloride, or other halogen ion, discharge at the anode face over long periods of time. While titanium is preferred for the construction of our anode, other valve metals, such as tantalum, zirconium or alloys thereof may be used.

The conductive electrocatalytic coating on the face of the anode is preferably composed of a major portion of titanium dioxide (TiO_2) or tantalum pentoxide (Ta_2O_5) together with a minor portion of an oxide of a platinum group metal capable of rendering the titanium dioxide semiconductive and of catalyzing chloride ion discharge at the face of the anode. Other electrocatalytic active coatings, such as electro-deposited or chemi-deposited platinum group metal coatings, may be used, but are not as desirable as the oxide coatings because of costs and unfavorable wear characteristics.

The anode face is preferably foraminant to minimize the bubble effect of the gas bubbles released at the anode face and avoid gas blanketing of the anode face.

One of the objects of the invention is to provide a dimensionally stable anode which will be economical in the use of the metal of construction, such as titanium, which is relatively expensive.

Another object of the invention is to provide a dimensionally stable anode which will give uniform current distribution from the anode lead-ins to the anode face.

Another object of the invention is to provide an anode having a low voltage drop from the anode lead-in to the anode face.

Another object of our invention is to provide a dimensionally stable anode with means for uniform distribution of current to the working face of the anode, which means will not interfere with the release of gas bubbles from the working face of the anode.

Another object is to provide an anode frame which is easy to construct from valve metals.

Other objects and advantages of the invention will appear as this description proceeds.

Referring now to the drawings, which illustrate preferred embodiments of the anodes of this invention:

FIG. 1 is a cross sectional view of a mercury electrolytic cell equipped with a flexible cell cover and dimensionally stable anodes of the present invention;

FIG. 2 is a plan view of one embodiment of the anode;

FIG. 3 is a sectional view along the line 3 — 3 of FIG. 2;

FIG. 4 is a sectional view along the line 4 — 4 of FIG. 2;

FIG. 5 is a plan view of another embodiment;

FIG. 6 is a sectional view along the line 6 — 6 of FIG. 5;

FIG. 7 is a sectional view along the line 7 — 7 of FIG. 5; and

FIG. 8 is a sectional view of another embodiment.

In the embodiment of the invention illustrated in FIG. 1, an electrolytic cell 10, of the type shown in U.S. Pat. No. 2,958,635 or No. 3,042,602, comprises a continuously flowing mercury cathode which flows over the cell base 11 beneath anodes 12 immersed in a brine solution, such as sodium chloride. The approximate brine level is indicated by the line A — A. However, the brine level may be anywhere between the top of the anodes and the bottom of the cell cover, if a gas release space is provided. Electric current is supplied to the anodes and a return conductor connected to the cathode cell base sets up a potential difference across the gap between the anode and cathode which causes the chloride ions to migrate to the anode, and the sodium ions to migrate to the flowing mercury cathode, where the resultant sodium forms an amalgam which is conveyed out of the cell to a denuder (not shown). The chlorine gas, in bubbles, rises from the mesh openings in the face of anodes 12 to an outlet passage from the cell cover, from which it flows to the chlorine recovery system.

The cell 10 is mounted between a pair of I-beams 13 and is inclined to cause the mercury to flow, by gravity, over the cell base 11. The cell comprises a bottom wall 14 and a pair of upstanding side walls 15, made of concrete, steel or other suitable rigid material. The side walls 15 are lined with a corrosi resistant insulating material 16, such as natural stone, or a coating of resin. The electrically conductive base 11, made of steel or the like, defines the inner bottom face of the cell. A conductor arrangement 17 secured to the undersurface of the bottom wall 14 includes spaced, upwardly projecting conductors (not shown) which contact the metal base 11, a conventional bus bar is connected to the conductor 17 to permit completion of the circuit. Conductors 17 form the negative connections to the circuit.

A plurality of spaced, transversely disposed pillars 18 span the cell above the I-beams 13 and are mounted on adjustable posts 19 which rest on and are releasably secured to the beams 13. The pillars 18 support a pair of longitudinally extending I-beams 20 on which is mounted an overlying elongated plate 21. Spaced along the plate 21 are suitable hook members 22 which are engaged by a conventional hoisting assembly (not shown) to remove the mounting structure overlying the cell when access to the interior, for repairs, is necessary.

A plurality of transversely extending anode supports 23 are secured to the bottom face of the I-beams 20 in a conventional manner, such as welding, and are used to support the anode structure in the cell. A plurality of downwardly projecting lead-in conductors 24, made of copper or other highly conductive metal, are spaced along the anode supports 23 and releasably secured to the latter in a conventional manner, as, for example, by threaded nuts 24a on the conductor on either side of the supports. Bus bar connections 25, secured to a positive electric power source (not shown) convey current to the bus bars 26 which extend transversely of the cell and are secured to the lead-in conductors 24. A flexible cover member 27, such as is disclosed in the aforementioned U.S. Pat. No. 2,958,635, overlies the cell and is secured along its longitudinal edges to the top of the I-beam walls 13. The cover includes spaced apertures which are aligned with and receive the downwardly projecting lead-in conductors 24 which are sealed to the cover 27 by nuts 28. The flexible cover permits limited adjustment of the anodes without removal of the cover. A rigid cover may, however, be used. All of this construction is more fully described in U.S. Pat. No. 2,958,635 and No. 3,042,602.

The anode assembly constituting the subject matter of this invention comprises a working face 30, comprising a titanium or tantalum mesh base covered with a conductor coating, such as a major portion of titanium dioxide (TiO₂) or tantalum pentoxide (Ta₂O₅) together with a minor amount of a platinum group metal oxide, capable of rendering the titanium dioxide conductive and of catalyzing chloride ion discharge at the face of the anode. Other electrocatalytically active coatings, such as electro-deposited or chemi-deposited platinum group metal coatings may be used. The term "mesh" is intended to include thin sheets of titanium or tantalum or of alloys of titanium or tantalum in foraminous or expanded form, wire screen, wire mesh and gauge, rolled wire mesh, punched and slotted sheet titanium or tantalum metal or alloys of titanium or tantalum.

The working faces 30 are connected by welding, riveting or other connections to a plurality of inverted U-shaped titanium conducting bars or channel bars 31, which are connected to the copper lead-in conductors 24 by means of internally screw threaded titanium bosses 32, welded or otherwise secured to the inverted U-shaped conductor bars 31.

The inverted U-shaped conductor bars 31 extend substantially from end to end of the anode working face 30 in one direction and are of such a width and are so spaced laterally along the anode face in the other direction, as to convey current substantially uniformly to the anode face. In the embodiments illustrated, two inverted U-shaped conductor bars 31 are shown — but a larger or smaller number may be used depending on the width of the anode and the number of anode lead-ins used. The ends of the conductor bars 31 are open.

In the embodiment illustrated in FIG. 2, the distances *a*, *b*, *c* and *d* are equal so that there is a uniform distribution of current to the half of the anode served by the right hand conductor bar 31. The same is true of the left half of the anode shown in FIG. 2. Where a single

U-shaped conductor bar is used to distribute current to an anode face, it should be of such width and so located on the anode face as to distribute current uniformly to the anode face. Thus, a single wide U-shaped

conductor bar 31 located at the center of the anode face, with legs 33 spaced one-half the lateral distance from the center to the edge of the anode will also distribute current uniformly over the anode face. Any number of conductor bars 31 may be used according to this principle to distribute current uniformly to the anode face; the lead-in conductors 24 being sufficient in number and spaced so as to provide uniform distribution of current longitudinally of the anode face.

The legs 33 of the inverted U-shaped conductor bars are preferably integral with the conductor bars and are bent outwardly, as shown in FIGS. 1 and 3, and welded or otherwise secured to the anode face 30. A plurality of holes 34 spaced along the inverted U-shaped conductor bars 31 permit the escape of gas bubbles, released beneath the inverted U-shaped conductor bars, into the electrolyte above the anodes and out of the cell into the gas recovery system. Notches 35 in legs 33 relieve strains and permit adjustment of the working face of the anode for levelling purposes. The U-shaped conductor bars may be made of heavy gauge foraminous metal, if desired.

Cross bars 36 of L-shape connect the conductor bars 31 adjacent the ends of the conductor bars and are preferably welded to the conductor bars, as illustrated in FIGS. 2 and 4, to give greater rigidity to the anode.

The lead-in conductors 24 are screw threaded into the bosses 32 so that the base of the lead-in conductors 24 make firm contact with the top of the inverted U-shaped conductor bars 31 to improve the conductivity at this point. The portion of the copper lead-in conductors 24 inside the cell 10 is protected from the corrosive effect of the electrolyte and the cell gases by titanium sleeves 37 which are either welded to the bosses 32, as illustrated in FIG. 6, or separate from the bosses and inserted in a groove 39 (FIG. 3) in the top of the boss, any gap being sealed by an O-ring 38. As illustrated in FIG. 3, the sleeves 37 are made separate from the bosses 32 so that the anode may be manufactured and shipped separately from the sleeves 37 and sleeves 37 of different height may be used when mounting the anodes in cells of different height. When the sleeves 37 are separate from the bosses 32, a fluid tight seal is formed by the O-ring 38 of neoprene or similar material.

The sleeves 37 are provided with a flanged top 37a which makes a fluid tight seal with the cell cover 27 when the anodes are assembled in a cell. The flanges 37a rest against a gasket 40 which is sealed against the cell cover 27 by an upper gasket 41a, washer 41b and nut 28 screwed on the lead-in conductor 24. The sleeves 37 are of larger diameter than the lead-in conductors 24 and are spaced from the lead-in conductors, as shown in FIG. 3.

In the embodiment illustrated in FIGS. 5, 6 and 7, the inverted U-shaped conductor bars 31 are similar to the corresponding conductor bars illustrated in FIGS. 1 to 4, but the legs 33a are not bent outwardly at their base and are welded directly to the foraminous anode face 30. The titanium protector sleeves 37 are welded to the bosses 33 and the upper end of the sleeves 37 are connected by connecting bars 42 welded or otherwise secured to the top of flanges 37a of sleeves 37. Cross bars 36a (FIG. 7) of L-shape are welded to the anode working face 30 at each end of the inverted U-shaped conductor bars 31. The connecting bars 42 at the top of the

sleeves and the cross bars 36a give the anode illustrated in FIG. 5 a high degree of rigidity.

FIG. 8 illustrates a modification of the inverted U-shaped conductor bars 31, in which the legs 43 are bars welded to a flat conductor bar 31a, carrying bosses 32, and to the anode working face 30. This construction has a higher internal resistance loss because of the larger number of welds and, hence, is a less preferred embodiment.

The anode working faces 30 are preferably foraminous titanium mesh which is welded to the legs 33 of the inverted U-shaped conductor bars 31. However, the anode faces may be any thin sheet of titanium or tantalum in foraminous or expanded form, wire screen, rolled wire mesh, punched or slotted sheet titanium, spaced rods or half-round forms, as illustrated, for example, in FIGS. 14 to 17 of U.S. Pat. No. 3,308,043.

The anode illustrated is economical in the use of the metal of construction such as titanium. It uses about 15 percent less metal than prior titanium anodes such as illustrated in U.S. Pat. No. 3,297,561, with better and more uniform distribution of current to the anode working face. The cross sectional area of the various parts is proportioned to the total current to be conducted to the anode working face, so that there is no waste of the metal of construction.

Before or after the anode has been assembled as described, the front, and optionally the back, of the working face 30 is given a conducting coating capable of conducting electrolysis current to the electrolyte and catalyzing chloride ion discharge at the working face over long periods of time. The coating may surround the mesh strands of the working face 30. Any suitable coating which will continue to conduct current to the electrolyte without becoming passivated and catalyze chloride ion discharge without high overvoltage may be used, such as electro-deposited or chemi-deposited coatings of platinum group metals (i.e., platinum, ruthenium, iridium, rhodium, etc.) or mixture thereof, or mixed oxides of platinum group metals and film forming metals.

One such coating may be provided as follows:

EXAMPLE I

Before or after the anode as illustrated and described in connection with FIG. 2 has been assembled, the anode face is cleaned by boiling at reflux temperature of 110° C in a 20 percent solution of hydrochloric acid for 40 minutes. It is dried and then given a liquid coating containing the following materials in the proportions given:

Ruthenium as $\text{RuCl}_3 \cdot \text{H}_2\text{O}$	10 mg (metal)
Iridium as $(\text{NH}_4)_2\text{IrCl}_6$	10 mg (metal)
Titanium as TiCl_3	56 mg (metal)
Formamide (NCONH_2)	10 to 12 drops
Hydrogen peroxide (H_2O_2 30%)	3 to 4 drops

per 50 square centimeters of anode face.

The coating is prepared by first blending or mixing the ruthenium and iridium salts containing the required amount of Ru and Ir in a 2 molar solution of hydrochloric acid (5 ml are sufficient for the above amounts) and allowing the mixture to dry at a temperature not higher than 50° C until a dry precipitate is formed. Formamide is then added to the dry salt mixture at about 40° C to dissolve the mixture. The titanium chloride, TiCl_3 , dissolved in hydrochloric acid (15 percent strength commercial solution), is added to the dissolved Ru-Ir salt

mixture and a quantity of hydrogen peroxide (30% H_2O_2 , about 16–22 milliliters) is added, sufficient to make the solution turn from the blue color of the commercial solution of TiCl_3 , to a brown-reddish color.

The coating mixture, thus prepared, is applied to both sides of the cleaned titanium anode face and to the sides of the interstices in the mesh, by brush, roller or the like, in multiple subsequent layers so that the coating surrounds the mesh. After applying each layer, the anode face is heated in an oven under forced air circulation at a temperature between 300° and 350° C for 10 to 15 minutes, followed by fast natural cooling in air between each of the layers, and after the last layer is applied the anode is heated at 450° C for 1 hour under forced air circulation and then cooled. This provides a ceramic type semi-conducting coating on the anode face.

The amounts of the three metals in the coating correspond to the weight ratios of 13.15 % Ir, 13.15 % Ru and 73.7 % Ti and the amount of noble metal in the coating corresponds to 0.2 mg Ir and 0.2 mg Ru per square centimeter of projected electrode area. In place of ruthenium, any platinum group metal may be used and in place of titanium, tantalum or alloys thereof, other valve metals and alloys may be used in the above formulation. If a platinum group metal coating is used on the mesh face, it may be applied by electro-deposition or by chemi-deposition either before or after the anode working face 30 is secured on the inverted U-shaped conductor bars 31.

The holes 34 in the inverted U-shaped conductor bars 31 permit chlorine bubbles or other gas bubbles formed in the electrolysis process to escape freely from the working face of the anodes and prevent gas blanketing.

OPERATION

In operation, current is supplied via the lead-in conductors 24 from the electric power source connected to the bus bar 25. Equal amounts of current are distributed to the lead-in conductors 24 which pass the same to each of the inverted U-shaped conductor bars 31. The current then flows along the inverted U-shaped conductor bars bidirectionally, i.e., current flows equally in both directions, along the conductor bars 31 and thus longitudinally of the anode working face 30. The current is then redispersed laterally by the legs 33 of the U-shaped conductor bars along the working face 30 secured to the legs of the bars 31. The conductor bars 31 are symmetrically spaced with reference to the anode working face so that there is equal distribution over the entire working face of the anode. Consequently, a uniform potential difference across the entire electrode gap is secured so that as the brine solution passes through the gap between the anode and cathode, the electrolytic process is performed uniformly throughout the entire length and width of the gap and chlorine bubbles flow upwardly through the mesh of the anode working face and also through the holes 34 in the inverted U-shaped conductor bars to the outlet passage provided in the cell cover for the collection of chlorine. The anode thus imparts a uniform potential difference over the entire electrode gap to maximize the liberation of chlorine or other products of the electrolysis process.

The use of massive perforated titanium conductor bars 31, in preference to mesh conductor bars 31, pro-

vides better conduction to the mesh anode working face, which is less electrically efficient, as a conductor, but because of the mesh configuration permits discharge of the chlorine bubbles from the anode working face and substantially eliminates gas blanketing of the anode working face.

The words "titanium" and "tantalum" are intended to include also alloys of these metals and the word "welding" is intended to include other equivalent methods of connecting metal parts such as riveting, screw threading the parts together, etc.

It will be evident to those ordinarily skilled in the art that various modifications and changes may be made from the embodiments shown without departing from the principles of this invention.

We claim:

1. A dimensionally stable anode for use in a flowing mercury cathode electrolysis cell comprising a planar mesh anode made of a valve metal provided with an electrically conductive, electrocatalytic coating on the working anode face, at least one laterally inverted, U-shaped conducting bar open at both ends connected by the integral legs of the bar to the mesh anode and extending substantially from end to end of the working face, the legs of the conductor bar being equally spaced laterally along the anode face in the other direction so the distance between the center line and each leg is equal and the distance between laterally parallel bars is twice the distance between the center line and each leg to provide uniform longitudinal distribution of current on the anode face, and means on said conductor bar for a detachable connection to electrical lead-ins.

2. The anode of claim 1, in which the inverted U-shaped conducting bars are of massive titanium and have gas escape holes therein and the anode is made of titanium.

3. The anode of claim 1, in which lead-in conductors are connected to the conductor bar and liquid and gas-proof sleeves surround and are spaced from the lead-in conductors inside the cell and extend between the inverted U-shaped conducting bars and the cell cover.

4. The anode of claim 3, in which the inverted U-shape conducting bars and the anode working face are titanium.

5. The anode of claim 2, in which the anode working face has a semi-conducting coating thereon.

6. The anode of claim 3, in which the sleeves are titanium and are separate from the inverted U-shaped conducting bars and have a flange making a liquid and gas-proof seal with the cell cover and a base making a liquid proof seal with the inverted U-shaped conducting bars.

7. The anode of claim 4, in which the inverted U-shaped conducting bars have bosses thereon for securing the lead-in conductors thereto and holes for the escape of gas bubbles released beneath the inverted U-shaped conductor bars.

8. The anode of claim 1, in which the legs of the inverted U-shaped conducting bars are flanged and the flanges are notched to permit relative movement of one part of the flange relative to the other for levelling ad-

justment.

9. The anode of claim 7, in which internally threaded titanium bosses are secured to the inverted U-shaped conducting bars for detachable connection with electrical lead in conductors.

10. An anode assembly for electrolytic cells which comprises a titanium sleeve having a flat titanium closure attached in fluid-tight manner across one end, a current lead-in rod at least partially within the sleeve and coaxial therewith having one end in contact with the titanium closure, and a foraminate titanium structure carrying on at least a part of its surface a coating comprising an operative electrode material, the said foraminate titanium structure lying in a plane parallel to the said titanium closure and being electrically connected thereby by titanium members which, together with the said closure, define an inverted channel shape.

11. An anode assembly according to claim 10, wherein the said titanium members and the titanium closure which together define an inverted channel shape have been fabricated from one integral piece of titanium metal.

12. An anode assembly according to claim 10, wherein the edges of the titanium channel shape are welded at intervals to the foraminate titanium structure.

13. An anode assembly according to claim 10, wherein the operative electrode material is selected from the group consisting of platinum group metals and oxides thereof.

14. An anode assembly according to claim 10, wherein the coating comprising an operative material consists of at least one oxide of at least one platinum group metal as the operative electrode material and titanium dioxide.

15. An anode assembly according to claim 14, wherein the said operative electrode material is ruthenium dioxide.

16. An anode assembly for electrolytic cells comprising:

- a downwardly-facing, open-ended, horizontally-elongated titanium channel member having a web portion and two depending flange portions integral with the web portion:
- a titanium sleeve secured at one end to said web portion in a fluid-tight manner so that said web portion closes said end, said web portion having at least one gas escape opening therethrough located intermediate said tube and each end of said channel:
- a current lead-in rod of smaller diameter than said sleeve at least partially within said sleeve coaxially therewith having one end in contact with said web portion: and
- a foraminate titanium structure lying in a plane parallel to said web portion and electrically connected to the lower edges of the flange portions, said foraminate structure carrying on at least a part of its surface a coating comprising an operative electrode material.

* * * * *