



- (51) International Patent Classification:  
*H04J 14/02* (2006.01)    *H04Q 11/00* (2006.01)
- (21) International Application Number:  
PCT/EP2012/069538
- (22) International Filing Date:  
3 October 2012 (03.10.2012)
- (25) Filing Language: English
- (26) Publication Language: English
- (71) Applicant: TELEFONAKTIEBOLAGET L M ERICSSON (PUBL) [SE/SE]; SE-164 83 Stockholm (SE).
- (72) Inventors: BOTTARI, Giulio; Via Dei Carabinieri 8, I-57123 Livorno (IT). CAVALIERE, Fabio; Via Marconi 12, loc Filettole, I-56019 Vecchiano (Pisa) (IT).
- (74) Agent: STASIEWSKI, Piotr; Ericsson Ltd, Unit 4, Middleton Gate, Guildford Business Park, Guildford Surrey GU2 8SG (GB).

- (81) Designated States (unless otherwise indicated, for every kind of national protection available): AE, AG, AL, AM, AO, AT, AU, AZ, BA, BB, BG, BH, BN, BR, BW, BY, BZ, CA, CH, CL, CN, CO, CR, CU, CZ, DE, DK, DM, DO, DZ, EC, EE, EG, ES, FI, GB, GD, GE, GH, GM, GT, HN, HR, HU, ID, IL, IN, IS, JP, KE, KG, KM, KN, KP, KR, KZ, LA, LC, LK, LR, LS, LT, LU, LY, MA, MD, ME, MG, MK, MN, MW, MX, MY, MZ, NA, NG, NI, NO, NZ, OM, PA, PE, PG, PH, PL, PT, QA, RO, RS, RU, RW, SC, SD, SE, SG, SK, SL, SM, ST, SV, SY, TH, TJ, TM, TN, TR, TT, TZ, UA, UG, US, UZ, VC, VN, ZA, ZM, ZW.
- (84) Designated States (unless otherwise indicated, for every kind of regional protection available): ARIPO (BW, GH, GM, KE, LR, LS, MW, MZ, NA, RW, SD, SL, SZ, TZ, UG, ZM, ZW), Eurasian (AM, AZ, BY, KG, KZ, RU, TJ, TM), European (AL, AT, BE, BG, CH, CY, CZ, DE, DK, EE, ES, FI, FR, GB, GR, HR, HU, IE, IS, IT, LT, LU, LV, MC, MK, MT, NL, NO, PL, PT, RO, RS, SE, SI, SK, SM, TR), OAPI (BF, BJ, CF, CG, CI, CM, GA, GN, GQ, GW, ML, MR, NE, SN, TD, TG).

[Continued on next page]

(54) Title: OPTICAL PATH VALIDATION METHOD

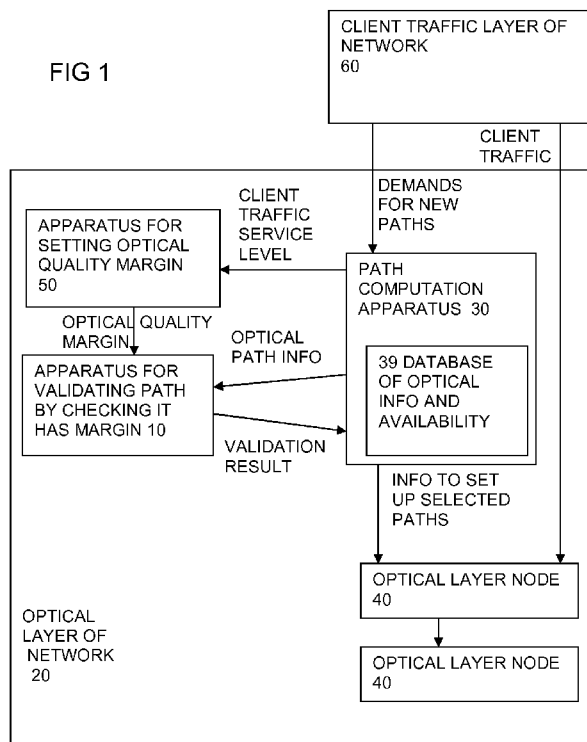

(57) Abstract: Validating a path in an optical layer (20) of a communications network, for client traffic having an associated service level, involves setting (100) an optical quality margin according to the service level associated with that client traffic. The optical quality margin indicates how close an estimated optical quality of the path can approach a level which produces a threshold error rate. This margin is used to check (110) whether the estimated optical quality is within the optical quality margin set according to the client traffic service level. Making the optical quality margin dependent on client traffic service level, can enable increased optical reach. This can give more flexibility in path selection and enable better matching to service levels of client traffic.

WO 2014/053175 A1

**Published:**

— *with international search report (Art. 21(3))*

## OPTICAL PATH VALIDATION METHOD

**5 Technical Field**

The present invention relates to methods of validating paths in a communications network, to corresponding apparatus and to corresponding computer programs, and to controllers for optical wavelength switches and to apparatus such as computers for off-line planning and to apparatus for  
10 multilayer nodes.

**Background**

In conventional optical networks there is always a limit to how far an optical signal can be transmitted along an optical path before the optical signal  
15 is lost in optical noise, or before there is sufficient noise to cause intolerable bit errors at the receiver. The target OSNR is the OSNR value at which the receiver reaches the target Bit Error Rate (BER). The OSNR margin, or simply "margin", is the difference between the estimated OSNR and the target OSNR. In conventional link engineering, the margin has to be budgeted in the design  
20 phase also taking into account system aging and other unexpected degradation events during the lifetime of the transmission infrastructure. Different physical layer phenomena are taken into account while estimating the margin.

**Summary**

25 Embodiments of the invention provide improved methods and apparatus. According to a first aspect of the invention, there is provided a method of validating a path in an optical layer of a communications network, for client traffic having a service level associated with that client traffic. There are steps of setting an optical quality margin according to the service level associated with  
30 that client traffic, and validating the path. The optical quality margin indicates how close an estimated optical quality of the path can approach a level which produces a threshold error rate in transmitted client traffic. A check is made

whether the estimated optical quality is within the optical quality margin set according to the client traffic service level.

By making the optical quality margin dependent on client traffic service level, this can enable increased optical reach. This can give more flexibility in path selection and enable better matching to service levels of client traffic. Overall this can help increase network capacity or reduce wasted capacity in the network. See figs 1 and 2 for example.

Any additional features can be added to the above features, or can be disclaimed. Some such additional features are set out below and described in more detail. One such additional feature is the service level representing a level chosen from at least a best effort service level and a guaranteed service level. This distinction between service levels indicating whether the service is guaranteed or not, is particularly useful since the optical quality margin can be reduced significantly for the best effort service level. See fig 3 for example.

Another such additional feature is the client traffic being packet based traffic, and the method having the step of obtaining the service level for the packet based client traffic. The additional flexibility provided by the adaptable optical quality margin is particularly useful here as such packet based traffic can often be dynamic and somewhat unpredictable in nature. See fig 3 for example.

Another such additional feature is the above method when used in an on-the-fly dynamic path computation step. The additional flexibility or additional optical reach is particularly useful for such path computation since it is often constrained by time or processing power limitations, at least for larger networks. See fig 2 or 3 for example.

Another such additional feature is the above method when used in off-line pre planning of paths for different service levels of possible client traffic, and having the subsequent step during on-line operation of the network, of selecting between the pre planned paths according to the actual service level of actual client traffic.

Since pre planning can enable more complex path computation, the additional flexibility and optical reach of the adaptable optical quality margin can be exploited more fully. See figs 4 and 5 for example.

Another such additional feature is the above method when used in  
5 validating a recovery path for client traffic. This is particularly useful as the recovery path is likely to be temporary and so can justify a lower optical quality margin, enabling longer recovery paths or more paths to be found, thus increasing the resilience of the network. See fig 6 for example.

Another such additional feature is the network having a packet layer, and  
10 the method having the preliminary step of passing an indication of the service level associated with the client traffic from a client layer control entity to a control entity of the optical layer, for use in setting the optical quality margin. This is one particular way of obtaining the service level information efficiently, making use of existing control entities, while preserving their control domains, to  
15 enable the adaptation of the optical quality margin. See fig 7 for example.

Another such additional feature is the network having at least one intermediate layer between the packet layer and the optical layer, and the step of passing the indication has the steps of passing the indication to a control entity of the intermediate layer, and from the control entity of the intermediate  
20 layer to the control entity of the optical layer. Again this makes use of existing control entities, while preserving their control domains. See figs 7 and 8 for example

Another such additional feature is the optical layer having flexible optical bandwidth multiplexing, and the validating step being part of a path computation  
25 involving selecting any one or more of optical bandwidth, optical bitrate, and optical modulation format for the client traffic. The adaptable optical quality margin adds further flexibility which is compatible with the flexible optical bandwidth multiplexing and can be exploited with little additional complexity of path computation. See fig 9 for example.

Another aspect of the invention provides apparatus having a processor configured to carry out any of the above methods.

Another aspect of the invention provides a computer program on a computer readable medium and having instructions which when executed  
5 cause the processor to carry out the method.

Another aspect of the invention provides apparatus for validating a path in an optical layer of a communications network, for client traffic having a service level associated with that client traffic, the apparatus having a processor configured to receive an indication of the service level associated with that client  
10 traffic, to set an optical quality margin according to the service level associated with that client traffic. The optical quality margin indicates how close an estimated optical quality of the path can approach a level which produces a threshold error rate in transmitted client traffic. The processor can be configured to check whether the estimated optical quality is within the optical quality margin  
15 set according to the client traffic service level.

Another such additional feature is control apparatus for setting up the validated path in an optical switch of the optical layer of the network.

Another such additional feature is the optical layer comprising a flexible optical bandwidth multiplexing optical layer and the processor being configured  
20 to check a path having a selected optical bandwidth, and the control apparatus being configured to set the optical bandwidth of the validated path in the optical layer according to a result of the check.

Another such additional feature is the apparatus being for off-line pre planning of paths for different service levels of possible client traffic.

Another such additional feature is apparatus being in the form of a  
25 multilayer node for a network having a client layer and the optical layer, and having a client layer control entity configured to pass an indication of the service level associated with the client traffic to a control entity for the optical layer, for

use in setting the optical quality margin.

Another aspect provides a corresponding computer program.

Any of the additional features can be combined together and combined with any of the aspects. Other effects and consequences will be apparent to those skilled  
5 in the art, especially compared to other prior art. Numerous variations and modifications can be made without departing from the claims of the present invention. Therefore, it should be clearly understood that the form of the present invention is illustrative only and is not intended to limit the scope of the present invention.

10

#### **Brief Description of the Drawings:**

How the present invention may be put into effect will now be described by way of example with reference to the appended drawings, in which:

Fig 1 shows a schematic view of apparatus for path validation in a network  
15 according to an embodiment,

Figs 2 and 3 show steps of a method according to an embodiment,

Fig 4 shows another apparatus embodiment involving validating pre planned paths,

Fig 5 shows steps of another embodiment involving validating pre planned  
20 paths,

Fig 6 shows steps of another embodiment involving recovery

Fig 7 shows steps of another embodiment involving obtaining the service level

Fig 8 shows a schematic view of a multilayer node for use in an embodiment,

Fig 9 shows another apparatus embodiment involving paths for a variable  
25 optical bandwidth optical layer.

Figs 10 and 11 show path validating implementations for embodiments,

Fig 12 shows a network view for an embodiment having a centralized NMS, and

Fig 13 shows an implementation using programs

#### **Detailed Description:**

The present invention will be described with respect to particular embodiments and with reference to certain drawings but the invention is not limited thereto but

only by the claims. The drawings described are only schematic and are non-limiting. In the drawings, the size of some of the elements may be exaggerated and not drawn to scale for illustrative purposes.

Definitions:

- 5 Where the term “comprising” is used in the present description and claims, it does not exclude other elements or steps and should not be interpreted as being restricted to the means listed thereafter. Where an indefinite or definite article is used when referring to a singular noun e.g. “a” or “an”, “the”, this includes a plural of that noun unless something else is specifically stated.
- 10 Elements or parts of the described nodes or networks may comprise logic encoded in media for performing any kind of information processing. Logic may comprise software encoded in a disk or other computer-readable medium and/or instructions encoded in an application specific integrated circuit (ASIC), field programmable gate array (FPGA), or other processor or hardware.
- 15 References to nodes can encompass any kind of node including ROADMs, cross connects, other switching nodes, not limited to the types described, not limited to any level of integration, or size or bandwidth or bit rate and so on. References to software can encompass any type of programs in any language executable directly or indirectly on processing hardware.
- 20 References to processors, hardware, processing hardware or circuitry can encompass any kind of logic or analog circuitry, integrated to any degree, and not limited to general purpose processors, digital signal processors, ASICs, FPGAs, discrete components or logic and so on. References to a processor are intended to encompass implementations using multiple processors which may
- 25 be integrated together, or co-located in the same node or distributed at different locations for example.
- References to optical quality can encompass any measure that represents the effectiveness of the transmission of data at the optical level, such as bit error rate or signal to noise ratio. It may encompass OSNR or noise level for a given
- 30 optical signal power or optical power level for a given optical noise level, or BER or similar. It may encompass measurements or predictions with or without error correction, and measurements with or without any regeneration or other

processing.

References to selecting a path are intended as encompassing selecting from pre-planned paths, or dynamically finding paths, and validating such paths, or selecting characteristics of the path such as bandwidth, bit rate, modulation  
5 format and so on.

References to validating are intended as encompassing any way of checking an optical path, including at least comparing an estimated OSNR with a threshold OSNR, and similar.

References to service level are intended to encompass any of best effort,  
10 guaranteed bandwidth, guaranteed error rate, guaranteed delay, characteristics suitable for video, characteristics suitable for HD video, characteristics suitable for VoIP, characteristics suitable for data which can tolerate retransmission, tolerate error bursts, is interruptible and so on.

#### Abbreviations:

15	BV-OXC:	bandwidth variable optical cross-connect
	DP-QPSK:	dual polarization quadrature phase shift keying
	HD	High Definition
	MPLS	Multi Protocol Label Switching
	OFDM:	Orthogonal frequency division multiplexed
20	OTN	Optical Transport Network
	PCE:	Path Computation Element
	QAM:	quadrature amplitude modulation
	ROADM:	Reconfigurable Add Drop Muxdemux
	RSA:	Routing and Spectrum Assignment
25	SDH	Synchronous Digital Hierarchy
	VoIP	Voice over Internet Protocol
	WSON:	wavelength switched optical network

#### Introduction

By way of introduction to the embodiments, how they address some issues with  
30 conventional designs will be explained.

In optical networks with many links, paths may be computed by a path

computation element on the fly, in response to traffic requests. To avoid the risk of the paths being too long and thus having insufficient margin evaluation of the margin is necessary, this is known as validation. This involves estimating the OSNR from known optical qualities of the links and optical components along the proposed path.

The use of a margin ensures a desired maximum BER level during the whole network lifetime. However, it's not "for free" because it implies untapped OSNR and, ultimately, bandwidth capacity. The tributary of an optical channel (wavelength) is typically a packet client possibly framed using one or more intermediate layers like Ethernet, OTN, MPLS, SDH/SONET. Such clients can require a guaranteed (e.g. "carrier class") or a "best effort" service level. In the case of best effort clients, the level of BER ensured by the margin at the optical layer can be too restrictive. A more relaxed BER level can meet the needs of the best effort client. In addition packet technology can use peculiar mechanism (e.g. retransmission) to mitigate the effects of a more relaxed BER.

At least some of the embodiments aim at reducing an excess of optical signal quality (OSNR margin, BER) that could be used to allocate additional bandwidth or distance when an optical channel is used to transport best effort packet clients. The embodiments can encompass amongst others, applications to optical networks for data center interconnection. Some embodiments can be used in a multi-technology packet-optical context where a collective, shared, intelligence (control plane/management plane) can exchange information between the two layers.

The packet clients can be wrapped in intermediate bearers (i.e. in Ethernet at layer two) and then sent to the optical layer to be embedded in two separate wavelengths, one per service level. The required service level at the packet layer is communicated to the optical layer so that, in case of best effort packet client, longer optical paths with reduced OSNR margins can be allocated, gaining bandwidth and reach. For carrier class clients the margin is unaffected.

Some embodiments are useful in a multi-technology landscape where a packet layer and an optical layer operate concurrently to transport traffic. The target node (apparatus) can be an integrated packet-optical node, or a router connected to a standalone optical node (e.g. a ROADM). Intermediate layers  
5 can be present between the packet layer and the optical layer.

A simple embodiment can be applied to a chain of nodes. Two packet clients are sent to the packet module of a source node. The first client, requires a best effort service level. The second client, requires a guaranteed service level. The packet clients are wrapped in the intermediate bearers (i.e. in  
10 Ethernet at layer two) and then sent to the optical layer to be embedded in two wavelengths. The two wavelengths shall arrive on the receiver with appropriate margins. For example the best effort client can be sent on a wavelength with a near zero margin on the receiver, while the guaranteed service level client shall use a wavelength with at least 3 dB of margin.

By looking at the required service level, the minimum tolerated optical quality margin for the wavelength can be decided. In case of preplanned wavelength paths, there can be different pre-planned paths for each service level, each validated to a different optical quality margin. Then in use, one of these pre planned wavelength is selected, having an optical quality margin  
15 compatible with the service driven requirement. In case of wavelengths activated on the fly, the activation can be done on a path/reach/rate/format which ensures the appropriate margin.  
20

#### Figs 1, 2, 3 embodiments showing path validation

Figure 1 shows a schematic view of apparatus for path validation in a  
25 network according to an embodiment of the invention. The network has at least an optical layer 20 and a client traffic layer 60. The client traffic layer 60 of the network is shown feeding demands for new paths for client traffic to a path computation apparatus 30 of the optical layer. This and other apparatus features can be implemented in hardware or more usually in software running  
30 on general purpose hardware. The path computation apparatus is able to

compute possible paths through the optical layer to the given destination node for the client traffic. This may depend on available capacity on different links of the optical layer, and such availability information is typically stored in a database 39 (which can be incorporated as a part of the path computation apparatus, or implemented separately) and continually updated. Whether the computed paths are of sufficient optical quality is determined by a validation function. This is carried out by apparatus 10 for validating paths by checking if the estimated optical quality is within an optical quality margin. This depends on optical path information provided by the path computation apparatus typically from its database. The validation here also depends on an optical quality margin, which is variable and set by an apparatus 50 for setting optical margin, according to a client traffic service level. The service level can be an indication of best effort or guaranteed (e.g. carrier class), or other levels. The validation is usually to check that the estimated optical quality is not too close to the threshold, and leaves sufficient margin, though in principle the check can also (or alternatively) be that the estimated optical quality is not too far from the threshold and thus effectively invalid for wasting too much margin.

The validation result is returned to the path computation apparatus and helps enable the path computation apparatus to select a path, and then set up the path in the optical layer 20 of the network. The validation can be carried out after path computation, or as part of the path computation. The optical layer is shown as having optical layer nodes 40, which may be for example wavelength switches, ROADMs or cross connects and so on. The optical layer can in principle be formed by a simple point to point link, or a network of links and nodes. Once the path is set up, the client traffic can flow from the source node through the optical layer to the destination node.

Figure 2 shows steps in the operation of the embodiment of figure 1 or other embodiments. At step 100 the optical quality margin for validating a given path is set according to the service level of the client traffic requesting the path. At step 110, the optical quality margin is used in checking the path. The estimated optical quality of the path is input. This can be calculated or looked up

and is a conventional step which can be carried out in various ways, and is described in more detail with reference to figures 10 and 11 below. An optical quality threshold is another input, which may itself be variable, if for example there are optical receivers of different performance in the optical layer. This threshold represents a quality which leads to an acceptable bit error rate. The validation involves checking whether the estimated optical quality is better than the threshold optical quality by sufficient margin, that sufficient margin being the variable optical quality margin set according to the service level. The optical margin is considered on the optical receiver interface (e.g. on a ROADM where the optical signal is terminated). At step 120 the selected and validated path can be set up and client traffic can be sent along it. In principle, these steps are used whether the paths are selected on the fly, or on a pre planned basis as discussed below in relation to fig 4.

Figure 3 shows steps in the operation of the embodiment of figure 1 or other embodiments and has steps similar to those of figure 2, but is intended to show an example where the service level indicates best effort or guaranteed or other level. At step 102 the optical quality margin for validating a given path is set according to whether the service level of the client traffic requesting the path is best effort or guaranteed or other. At step 110, as in figure 2, the optical quality margin is used in checking the path. The estimated optical quality of the path is input to check whether it is within the optical quality margin as described above.

#### Figs 4, 5 pre planned example

Figure 4 shows a schematic view of another embodiment, similar to that of fig 1, but showing an example of additional features involved in selecting and validating pre planned paths, which are then stored for use later. An off-line path computation apparatus 33 is provided, coupled to receive potential traffic requests rather than actual ones, and thus can select paths for some or every combination of source and destination, and for different levels of service. The apparatus for setting the optical quality margin and for checking whether the estimated optical quality of the paths is within the adaptable optical quality margin are as shown in fig 1. The pre planned paths that are validated are

stored in store 34. There they can be looked up by a path computation apparatus 30 which receives demands for new paths from the client layer 60. Other parts can be as shown in fig 1.

Figure 5 shows steps in the operation of the embodiment of figure 4 or other embodiment. Steps 100, 111 and 113 are used in the off line pre planning phase. At step 100 the optical quality margin for validating a given path is set according to the service level of the client traffic requesting the path. At step 110, the optical quality margin is used in checking the path for the possible traffic. The estimated optical quality of the path is an input, and may be calculated by the off line path computation apparatus. An optical quality threshold is also input, and the pre planned path can be validated by checking if the estimated optical quality leaves more margin than the selected optical quality margin from the threshold. This can be repeated for some or all of the possible source-destination pairs and for all the service levels, and the selected paths can be stored at step 113.

During on-line operation of the network, at step 115, in response to a demand for a path for client traffic, there is a step of looking up one of the stored pre planned paths. This store can be addressed using the source and destination information and the service level of the client traffic. As before, at step 120, the selected and validated path is set up and client traffic can be sent along it.

#### Fig 6, recovery example

Figure 6 shows steps in the operation of the embodiment of figure 1 or other embodiments and has steps similar to those of figure 2, but is intended to show an example where the path selection is for a recovery path. In this case there are preliminary steps of detecting a fault and initiating a recovery procedure at step 95, and computing possible recovery paths at step 97. The possible path or paths are then validated. This involves obtaining estimated optical quality of the possible recovery paths at step 97, and setting an optical quality margin at step 100, according to the service level associated with the

traffic. This service level or the resulting optical quality margin can be revised to be less stringent, to reflect the fact that a recovery path is likely to be temporary, and is usually urgent. Further steps 110 and 120 are as fig 2.

Fig 7, indication of service level

5 Figure 7 shows steps in the operation of the embodiment of figure 1 or other embodiments and has steps similar to those of figure 2, but is intended to show an example of additional features for obtaining the service level information, for use in setting the adaptable optical quality margin. At step 90 the indication of service level is passed from a control entity for the client layer,  
10 to a control entity for the optical layer. This can be for example passed with the other information usually needed by the optical layer, such as source and destination, and bandwidth for the traffic demand. This could be implemented in various ways, such as using the PCE communication protocol (PCEP) for sending path computation requests to a PCE (i.e., using a PCEP PCReq  
15 message). The control entity for the optical layer can be for example the path computation apparatus, though in principle it could be other parts. For example since the service level information is needed by the optical quality margin setting apparatus, this could be an example of a control entity and the service level information could be sent directly to this part. The path computation and  
20 validation functions can be centralized or distributed or partially distributed, and likewise the control entity for the client traffic layer may be centralized or distributed or partially distributed. Hence the passing of the service level information may take place across different nodes, or may take place within the same multilayer node.

25 Fig 8, multilayer node example

Figure 8 shows a schematic view of a multilayer node and shows an example of the transfer of an indication of service level for client traffic, from a client layer control entity to an optical layer control entity. In the multilayer node  
130 there are shown three layers for processing the traffic, and three  
30 corresponding control entities for the layers. A packet layer subsystem 140 may

be a packet switch for example, and this is coupled to a corresponding packet layer control entity 170. This may have routing tables for example and may implemented in hardware or software running on general purpose processing hardware as usual. This may be part of a wider packet layer control structure  
5 which can undertake end to end routing at a logical level, and leaves the optical layer to do the routing at the physical level and to do the wavelength assignment for the path.

The packet layer subsystem has a path for traffic to an intermediate layer subsystem 150. This may be for example an Ethernet switch or MPLS  
10 processing layer or OTN processing layer. A corresponding control entity is shown as the intermediate layer control entity 180, coupled to the intermediate layer subsystem 150. This has a path for traffic to an optical layer subsystem 160, which can be for example a ROADM, an optical cross connect, an optical regen or a wavelength switching system for example. This is coupled to an  
15 optical layer control entity 190, which may be implemented by parts 10, 30, 39, 50 shown in figure 1 for example. The transfer of the service level information for particular client traffic is shown by dashed arrows from the client interface (not shown) to the packet layer control entity 170, and from there to the intermediate layer control entity 180, which passes it on to the optical layer  
20 control entity 190. Here it is used for setting the optical quality margin.

Fig 9, example using variable optical bandwidth optical layer

Figure 9 shows a schematic view similar to that of fig 1, but intended to show an example of the additional features for application to an optical layer 220 having flexible or variable optical bandwidth allocation. Thus there is a path  
25 computation apparatus 35 for computing paths for a variable optical bandwidth layer. The nodes shown are variable optical bandwidth nodes 240. Otherwise the remaining parts shown are similar to those of figure 1 and corresponding reference numerals have been used. So the apparatus for setting optical quality margin and the apparatus for validating the path can operate as described  
30 above, even though the path computation is more complex for this type of optical layer.

Path computation for a flexible optical bandwidth optical layer can exploit several techniques which, depending on the modulation format, are able to allocate the required frequency slots along the path while limiting the spare capacity. A database can be provided for storing a network topology, and current slot availability information. A flexible-grid WSON network has a number of variable bandwidth nodes 240 which may be for example ROADMs or BV-OXCs. Traffic demands are fed to the PCE. The PCE is coupled to the database to access the information about the network topology and the slot availability. The PCE is able to compute a route for the new path and to assign frequency slots to the new paths. An indication of the assigned frequency slots is sent to the relevant nodes in the network so that the new traffic can be passed over the network. The indication is also sent to the database to enable it to update the current slot availability information.

An example of a network to which this can be applied is a transparent WSON with E nodes and V bi-directional links, in which the nodes support transmission and reception at 100 and 400 Gb/s. 100 Gb/s is supported by dual polarization quadrature phase shift keying (DP-QPSK) or other techniques. 400 Gb/s is supported by dual polarization and 4-quadrature amplitude modulation (QAM), or 16-QAM, or 64-QAM for example. More generally, examples of modulation types are at least 4-QAM, 16-QAM, and 64-QAM, using a single carrier, or multicarrier types such as OFDM.

Bandwidth requirements of 100 Gb/s and all-optical reach are summarized in: T. Pfau, "Hardware requirements for coherent systems beyond 100G," in ECOC 2009. An example of a model of quality of transmission for 100 Gb/s is detailed in Sambo, N.; Secondini, M.; Cugini, F.; Bottari, G.; Iovanna, P.; Cavaliere, F.; Castoldi, P.; , "Modeling and Distributed Provisioning in 10–40– 100-Gb/s Multirate Wavelength Switched Optical Networks," *Lightwave Technology, Journal of* , vol.29, no.9, pp.1248-1257, May1, 2011.

Each link can support S slots of bandwidth B (e.g., S = 320 if B = 12.5 GHz). PCE is devoted to path computation and slot assignment and it is aware of the QoT of any path in the network. Upon lightpath request of the given bit-rate from source s to destination d, s exploits the PCE communication protocol (PCEP)

for submitting path computation requests to the PCE (i.e., using a PCEP PCReq message), which must carry bit-rate information. The database can be a traffic engineering database with detailed and updated slot availability information, i.e. the status (reserved or available) of each slot of bandwidth B on every link. In  
5 an example, the PCE performs path computation depending on the bit-rate, the admitted modulation formats (i.e., the ones guaranteeing the QoT at the given bit-rate), and the available slots along the path. Typically for a path connecting s to d, depending on the admitted modulation format and bit-rate, the lightpath requires n-adjacent slots along the whole path. Also, similar to the wavelength  
10 continuity constraint, those slots must satisfy the slot continuity constraint, i.e. the same slots are available in all the links along the path.

Dynamic RSA schemes have been proposed in the context of optical orthogonal frequency-division multiplexing (OFDM) where the fine granularity of elastic requests is specifically exploited to occupy a freely variable number of adjacent  
15 sub-carriers, as shown in: K. Christodoulopous, et al., "Dynamic bandwidth allocation in flexible OFDM-based networks," in Proc. of OFC/NFOEC, 2011. Frequency slot assignment can be based on first fit technique, meaning a lowest indexed available set of slots is chosen for a new path.

#### Figs 10, 11, path validation

20 Figures 10 and 11 show two examples of implementations of the optical path validation function. In figure 10 an OSNR calculation 300 is followed by a subtraction of OSNR penalties calculated at 310. This first OSNR calculation may depend on the signal, modulation format and other characteristics. A subtraction of the acceptable OSNR threshold 320 leaves a remaining margin  
25 which can be compared at 330 with the adaptable margin set according to the service level. The result is a value which if positive, indicates successful validation. If negative, this indicates unsuccessful validation. Of course there can be multiple levels of output rather than a binary pass or fail output.

OSNR penalties are related to optical impairments affecting the signal  
30 transmission in fiber. For example there can be manufacturing variations, jitter penalty, PMD penalty, dispersion, connector loss and fiber loss. For each

impairment is estimated a penalty in dB which is subtracted from the “gross OSNR”, that is the ideal OSNR if no impairments would be present, to obtain a “net OSNR” which is compared with an OSNR threshold. The difference between the net OSNR and the threshold is the margin. By keeping a high margin, like 3 dB, the transmission will be safer but the possible path will be shorter.

Figure 11 shows an alternative embodiment in which the adaptable optical quality margin is implemented by adjusting 340 the OSNR threshold 320, the adjustment being according to service level of the client traffic. Optionally the output is fed to a comparison 345 for comparing with a zero threshold to give a binary output. The end result is the same as in figure 10. Other implementations can be envisaged in which the adaptable margin is used to adjust the functions 300 or 310, and again the end result will be the same.

#### Fig 12, network view

Figure 12 shows a view of a part of a network to show an example of the additional feature of the path computation and validation for the optical layer being centralized at the NMS. A number of nodes of the network are shown, in particular a source node 430 and a destination node 460, with respect to a particular client traffic. For other client traffic, others of the nodes may be source and destination nodes. The source node has a packet layer subsystem 440, and an optical layer subsystem 450. The destination node 460 has a corresponding packet layer subsystem 440, and an optical layer subsystem 450. For intermediate optical nodes 455 only the optical layer subsystem 450 is shown, though there may be other parts in such nodes. The optical layer subsystems can be for example ROADMs or optical cross connects, or optical switches such as wavelength selective optical switches. Optical links for traffic are shown between the nodes. A dashed line 1200 shows a path selected for the client traffic. A multi layer centralized NMS 420 is shown. This has a client layer control entity 490 able to communicate with the packet layer subsystems in each of the nodes. The centralized NMS also has an optical layer path computation entity 410 with validation using adaptable optical quality margin.

This can operate as described above at least in relation to figure 2, so that the optical quality margin is adapted according to the service level of the client traffic. The service level is passed from the client layer control entity 490 to the centralized optical layer path computation entity 410. The control functions may  
5 be implemented by providing a control agent at each node for cooperating with the centralized control entities.

#### Fig 13 program based example

Figure 13 shows a schematic view of another embodiment, similar to that of fig 1, but showing an example of an implementation of the various functions  
10 using programs running on a general purpose processor 540. The functions of path computation, setting optical quality margin, and validating the path using the optical quality margin, can operate as described above. In this case they are implemented by a path computation program 530, a program 550 for setting optical quality margin, and a program 510 for validating the path by checking  
15 the estimated quality against the set optical quality margin as described above. Other additional features as described above can also be implemented by such programs running on one or more general purpose processors.

#### Concluding remarks

This service level dependent optical margin can help with content provider  
20 demand for reduced CAPEX, compatibly with their different QoS requirements with respect to traditional Telco operators. It can be simple to implement in a multi-technology network. It is compatible with different layer combinations (intermediate layers between packet and optical do not prevent the use of the method). It can help reduce the waste of resources typical of a “service level  
25 blind” optical layer where an excess of optical signal quality is unnecessarily allocated for best effort services. It can add a useful feature to the packet-opto solutions to further increase the bandwidth exploitation obtained by the synergy between the two layers. It is compatible with existing/legacy optical devices by allowing, for this kind of nodes, the activation of wavelengths with a reduced  
30 margin.

Other variations and additions can be envisaged within the claims.

## Claims:

1. A method of validating a path in an optical layer of a communications network, for client traffic having a service level associated with that client traffic, the method having the steps of
  - 5 setting an optical quality margin according to the service level associated with that client traffic, the optical quality margin being indicative of how close an estimated optical quality of the path can approach a level which produces a threshold error rate in transmitted client traffic, and
  - 10 checking whether the estimated optical quality is within the optical quality margin set according to the client traffic service level.
2. The method of claim 1, the service level representing a level chosen from at least a best effort service level and a guaranteed service level.
- 15 3. The method of claim 1 or 2, the client traffic being packet based traffic, and the method having the step of obtaining the service level for the packet based client traffic.
- 20 4. The method of any preceding claim, when used in an on-the-fly dynamic path computation step.
- 25 5. The method of any preceding claim, when used in off-line pre planning of paths for different service levels of possible client traffic, and having the subsequent step during on-line operation of the network, of selecting between the pre planned paths according to the actual service level of actual client traffic.

6. The method of any preceding claim, when used in validating a recovery path for client traffic.

5 7. The method of any preceding claim, the network having a packet layer, and the method having the preliminary step of passing an indication of the service level associated with the client traffic from a client layer control entity to a control entity of the optical layer, for use in setting the optical quality margin.

10

8. The method of claim 7, the network having at least one intermediate layer between the packet layer and the optical layer, and the step of passing the indication has the steps of passing the indication to a control entity of the intermediate layer, and from the control entity of the intermediate layer to the  
15 control entity of the optical layer.

9. The method of any preceding claim, the optical layer having flexible optical bandwidth multiplexing, and the validating step being part of a path computation involving selecting any one or more of optical bandwidth, optical  
20 bitrate, and optical modulation format for the client traffic.

10. Apparatus having a processor configured to carry out the method of any preceding claim.

25 11. A computer program on a computer readable medium and having

instructions which when executed cause the processor to carry out the method of any of claims 1 to 9.

12. Apparatus for validating a path in an optical layer of a communications network, for client traffic having a service level associated with that client traffic, the apparatus having:

a processor configured to receive an indication of the service level associated with that client traffic, to set an optical quality margin according to the service level associated with that client traffic, the optical quality margin being indicative of how close an estimated optical quality of the path can approach a level which produces a threshold error rate in transmitted client traffic,

the processor also being configured to check whether the estimated optical quality is within the optical quality margin set according to the client traffic service level.

13. The apparatus of claim 12 and having control apparatus for setting up the validated path in an optical switch of the optical layer of the network.

14. The apparatus of claim 13, the optical layer comprising a flexible optical bandwidth multiplexing optical layer and the processor being configured to check a path having a selected optical bandwidth, and the control apparatus being configured to set the optical bandwidth of the validated path in the optical layer according to a result of the check.

15. The apparatus of claim 12 in the form of apparatus for off-line pre planning of paths for different service levels of possible client traffic.

16. The apparatus of claim 12 in the form of a multilayer node for a network having a client layer and the optical layer, and having a client layer control entity configured to pass an indication of the service level associated with the client traffic to a control entity for the optical layer, for use in setting
- 5 the optical quality margin.

FIG 1

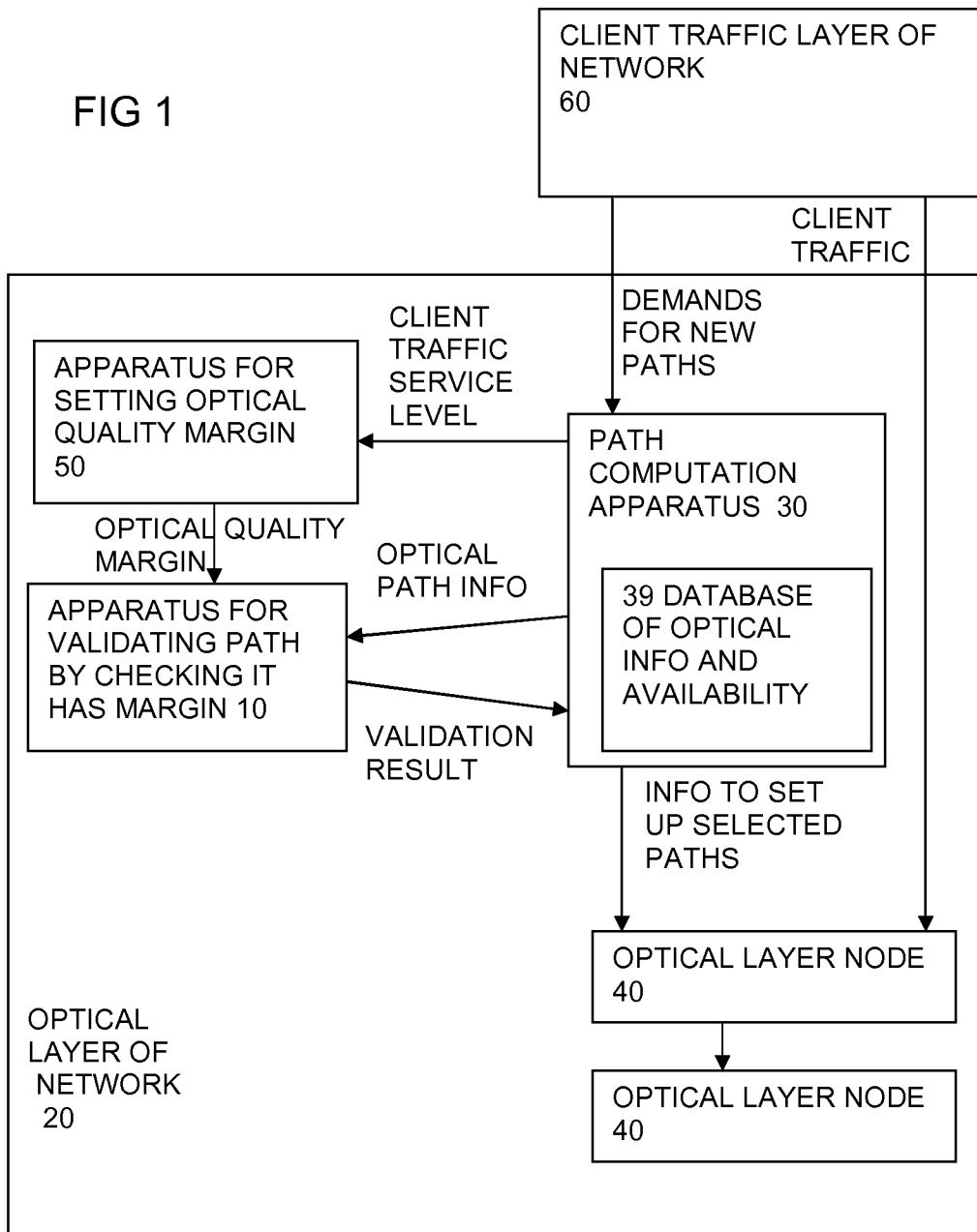

FIG 2

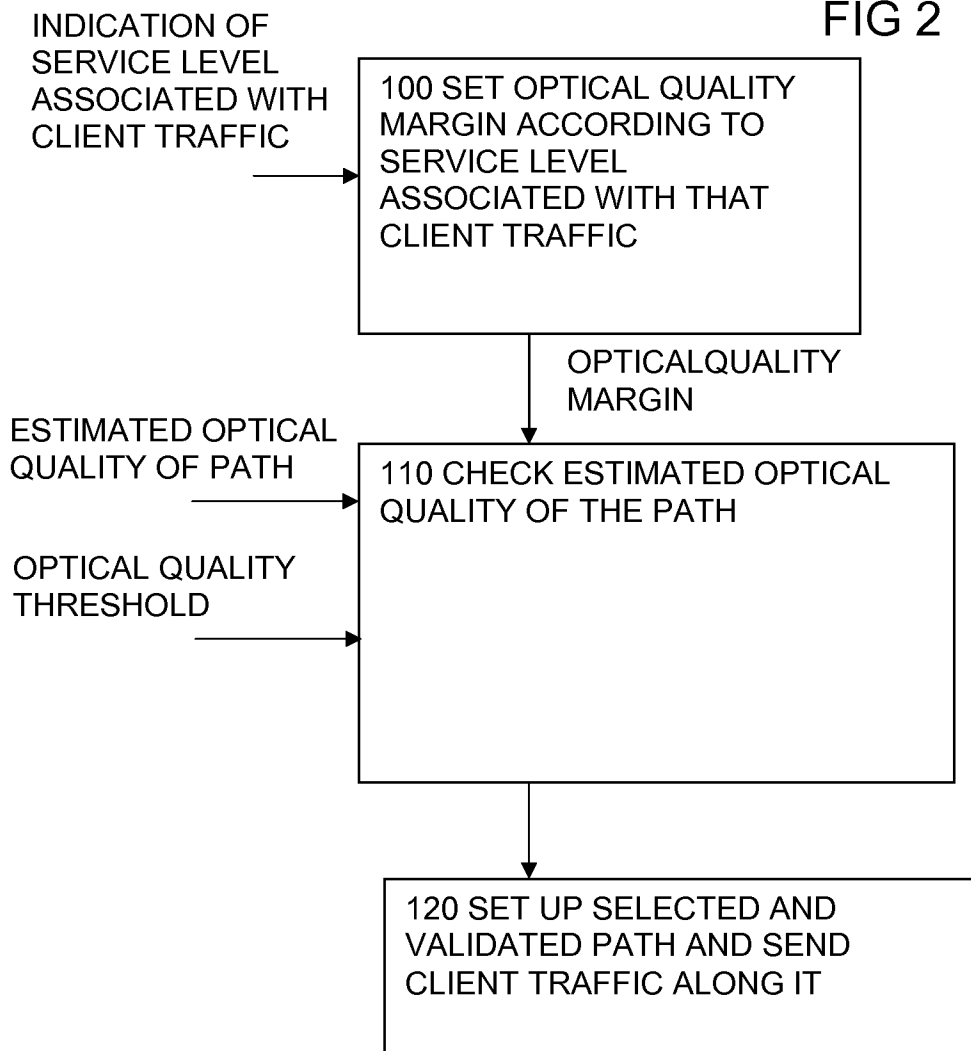

FIG 3

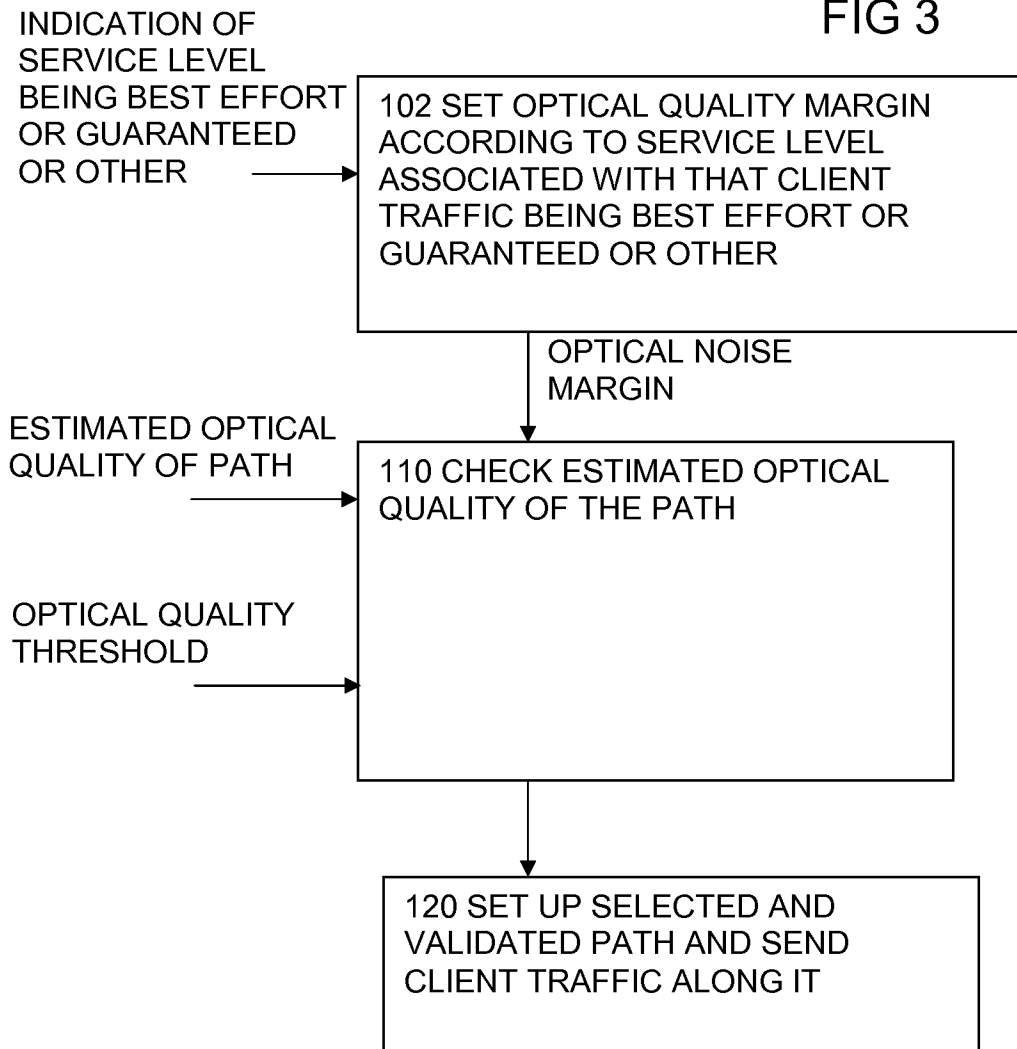
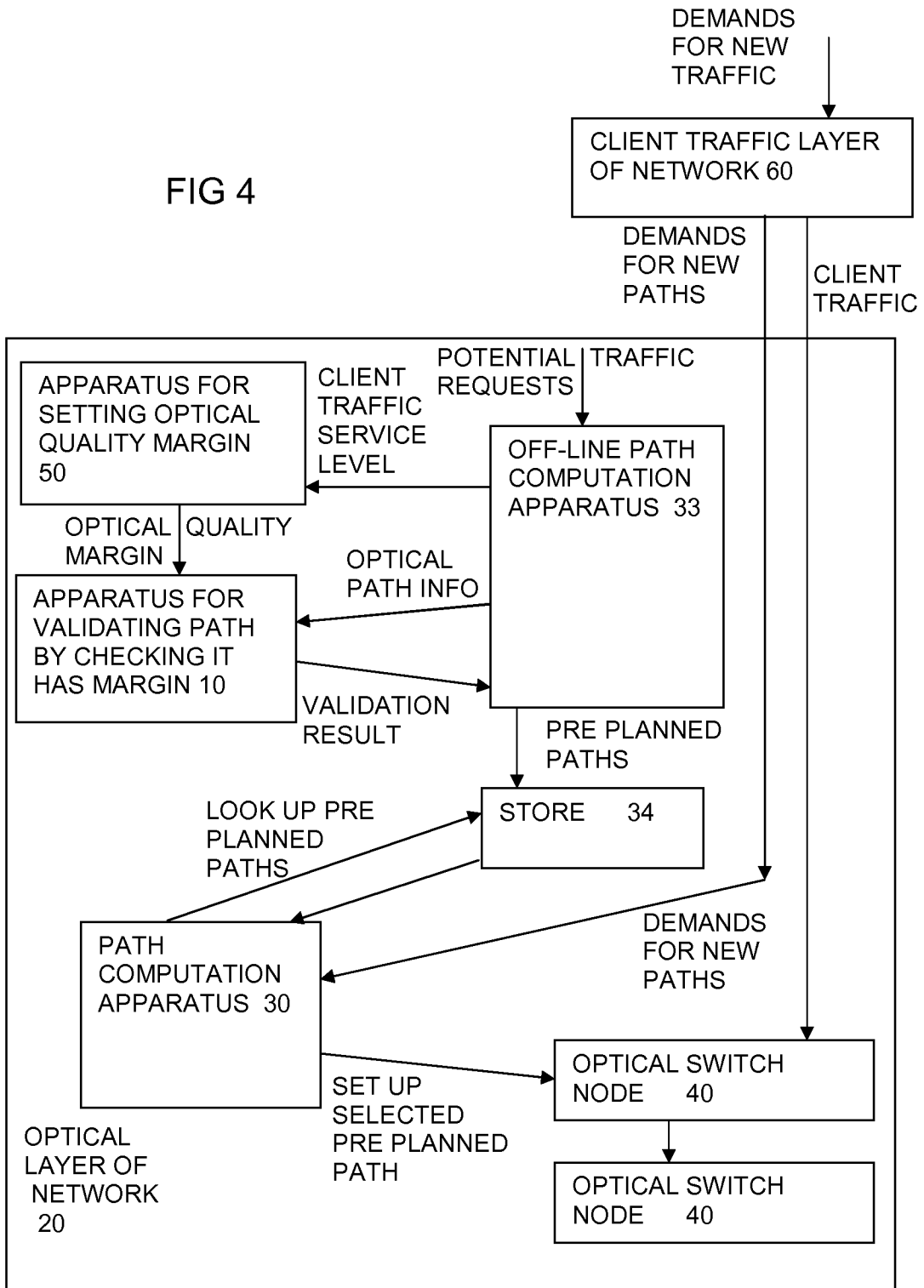
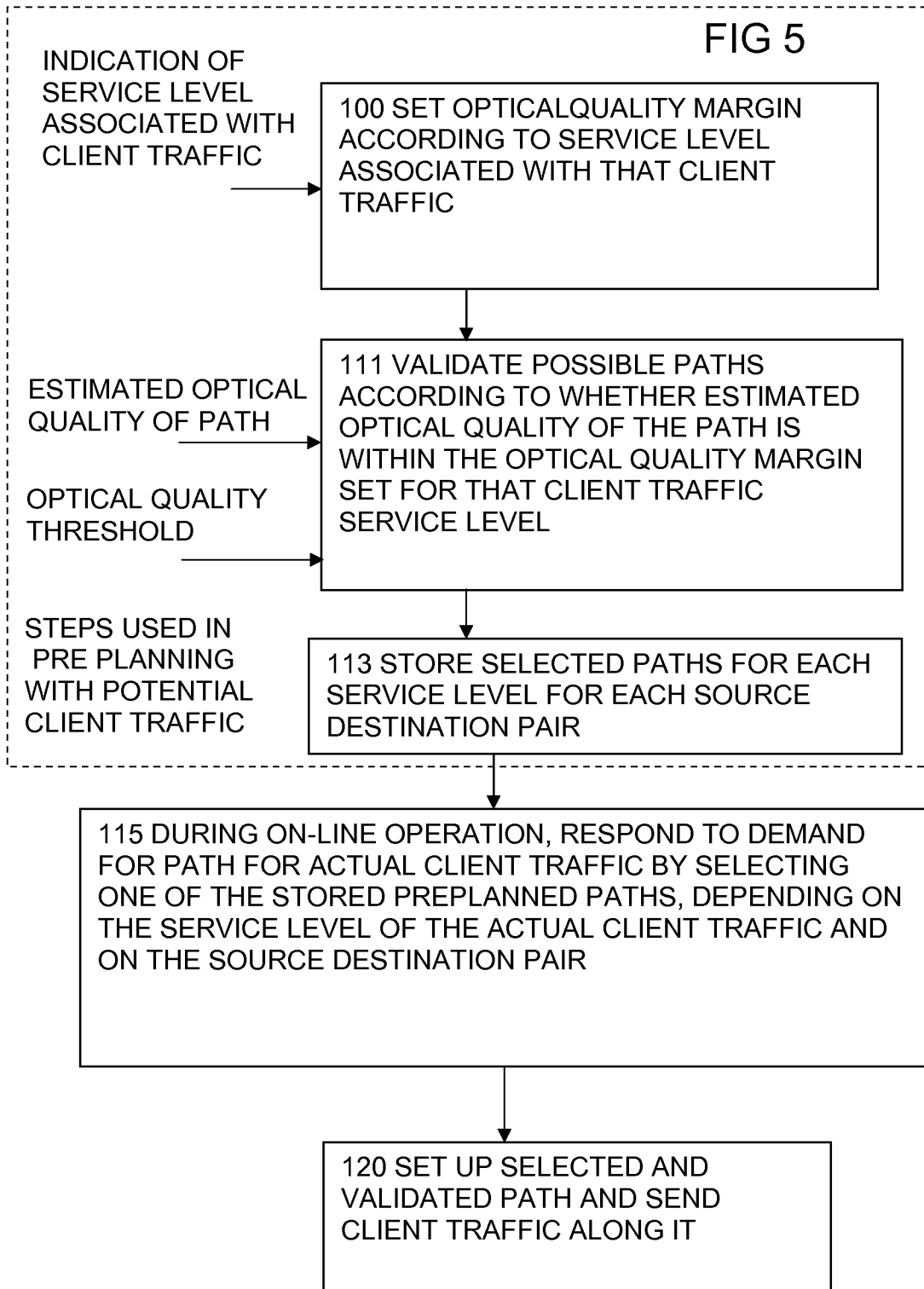
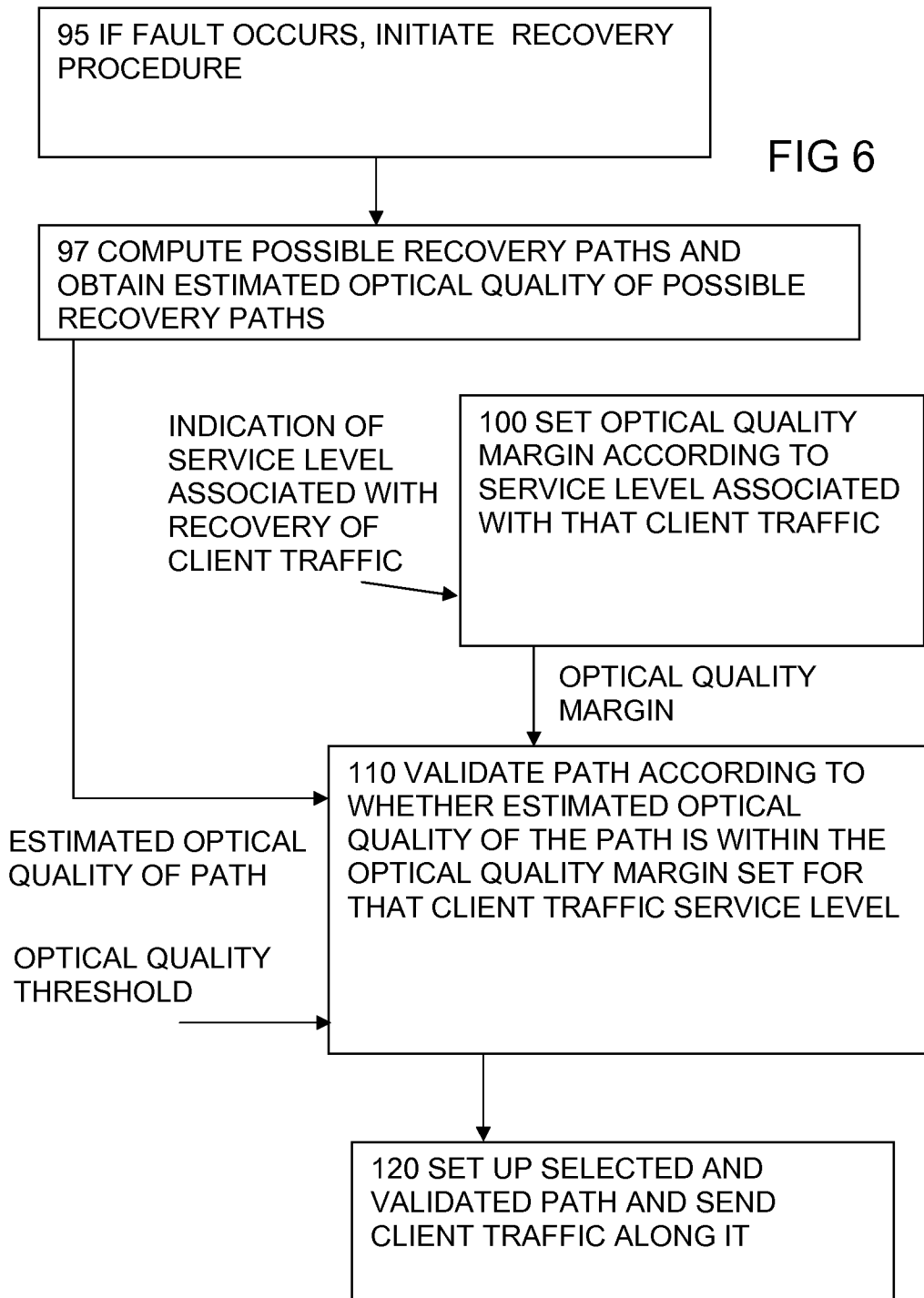
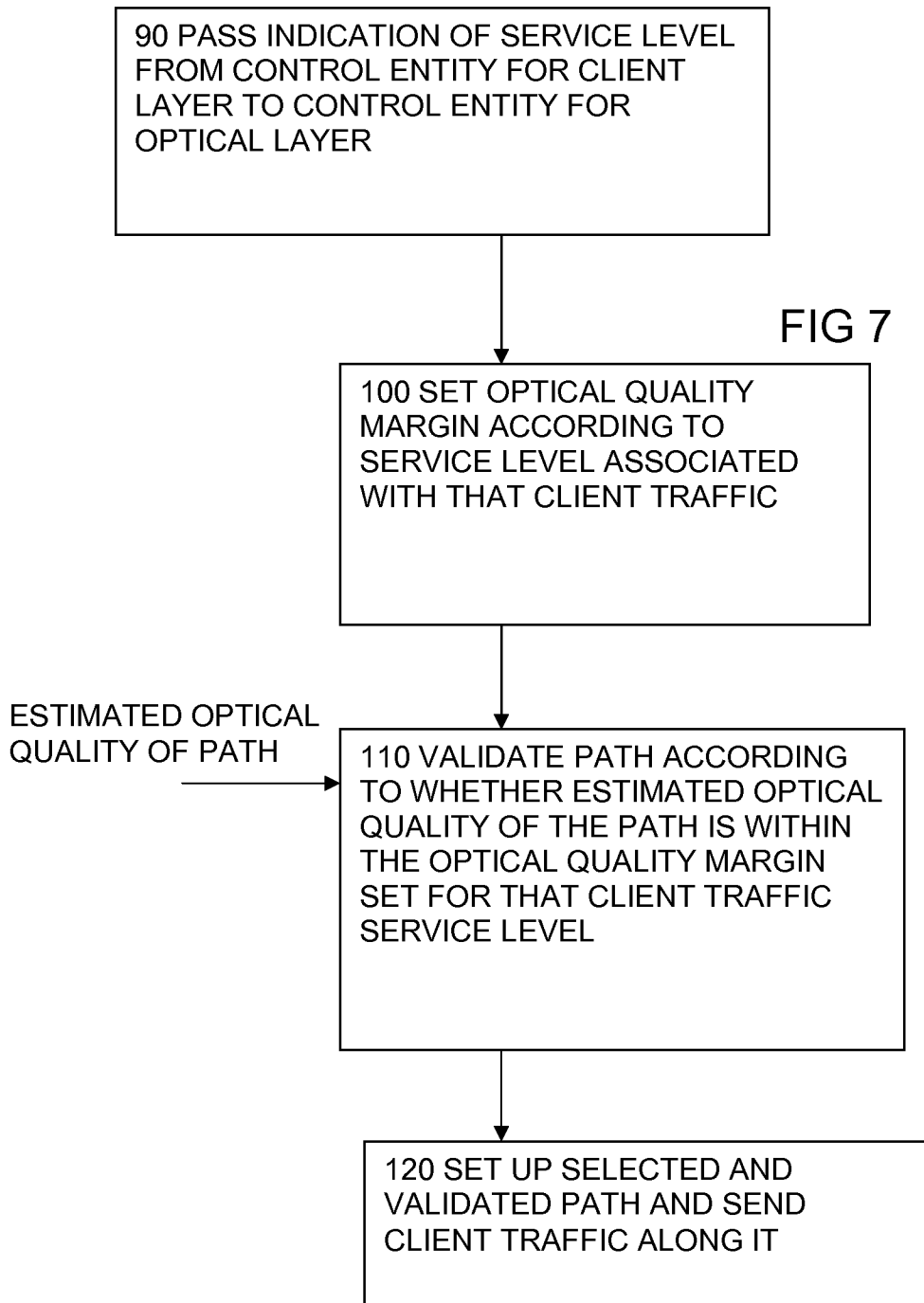

FIG 4









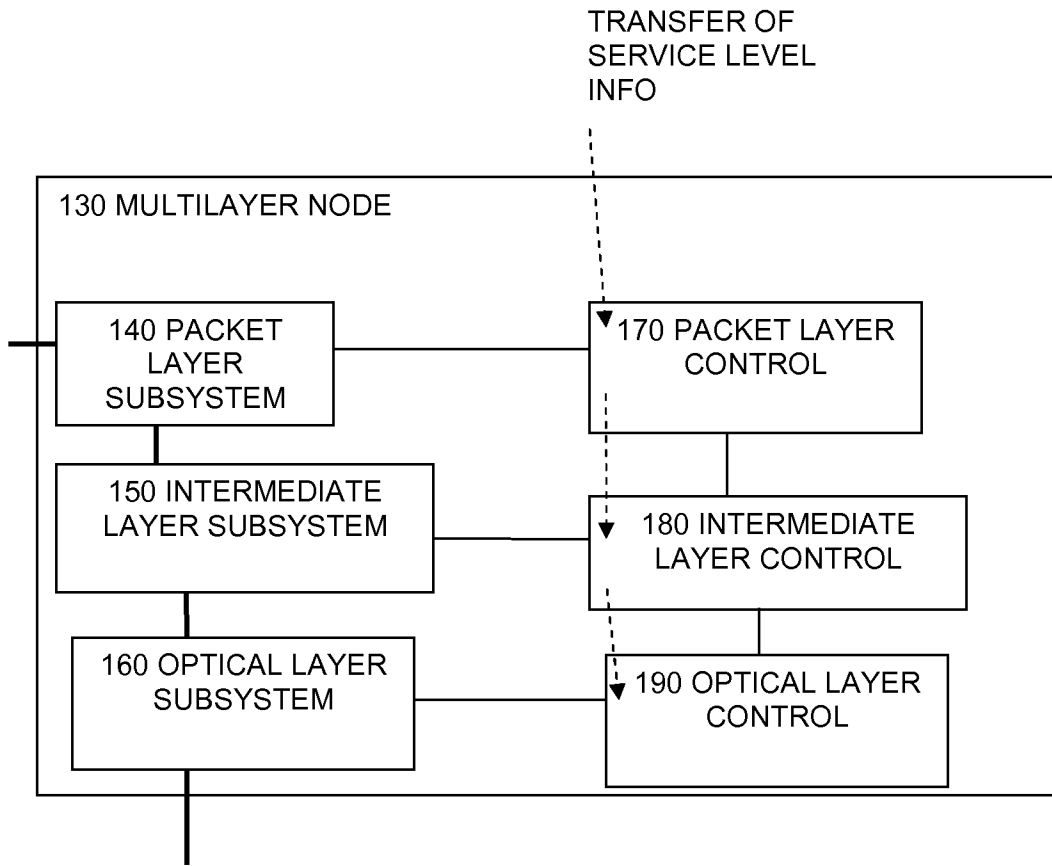
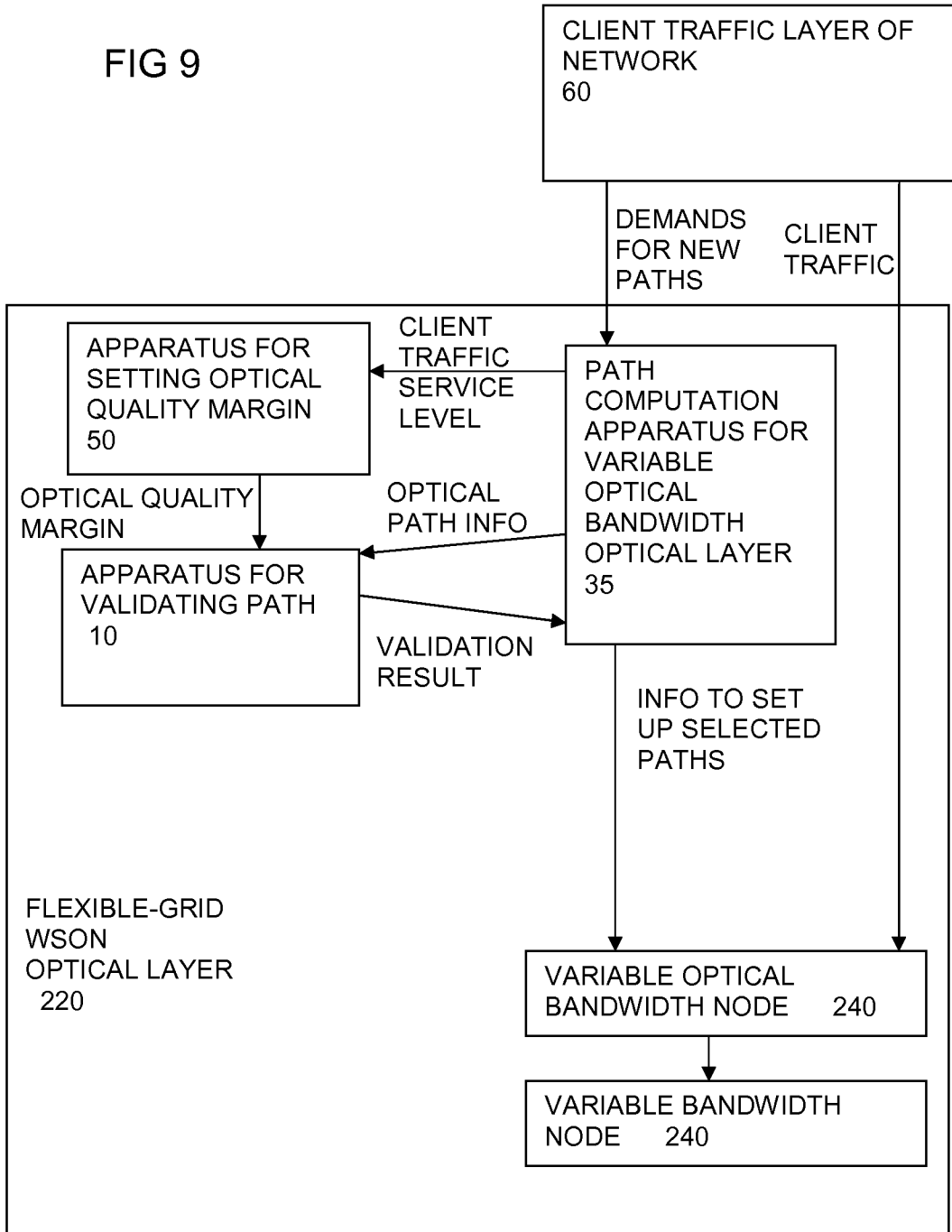

FIG 8

FIG 9



PATH  
CHARACTERISTICS,  
OPTICAL SIGNAL  
CHARACTERISTICS

FIG 10

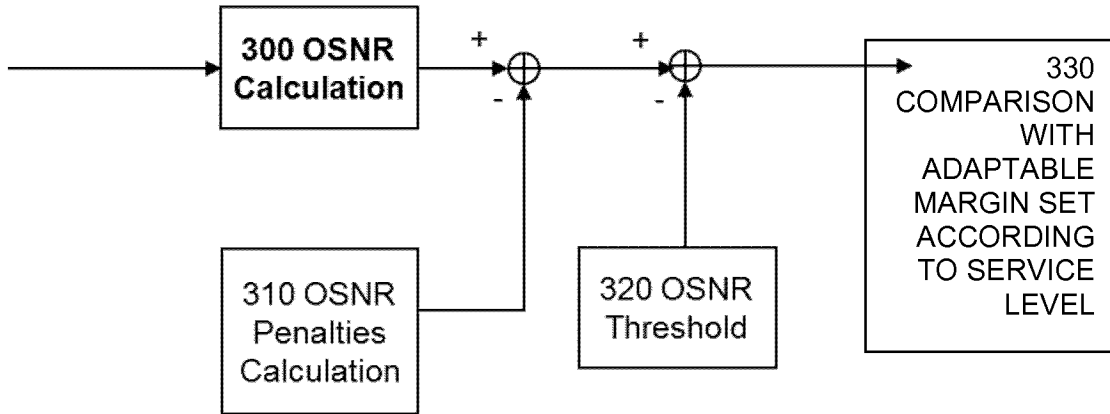

PATH  
CHARACTERISTICS,  
OPTICAL SIGNAL  
CHARACTERISTICS

FIG 11

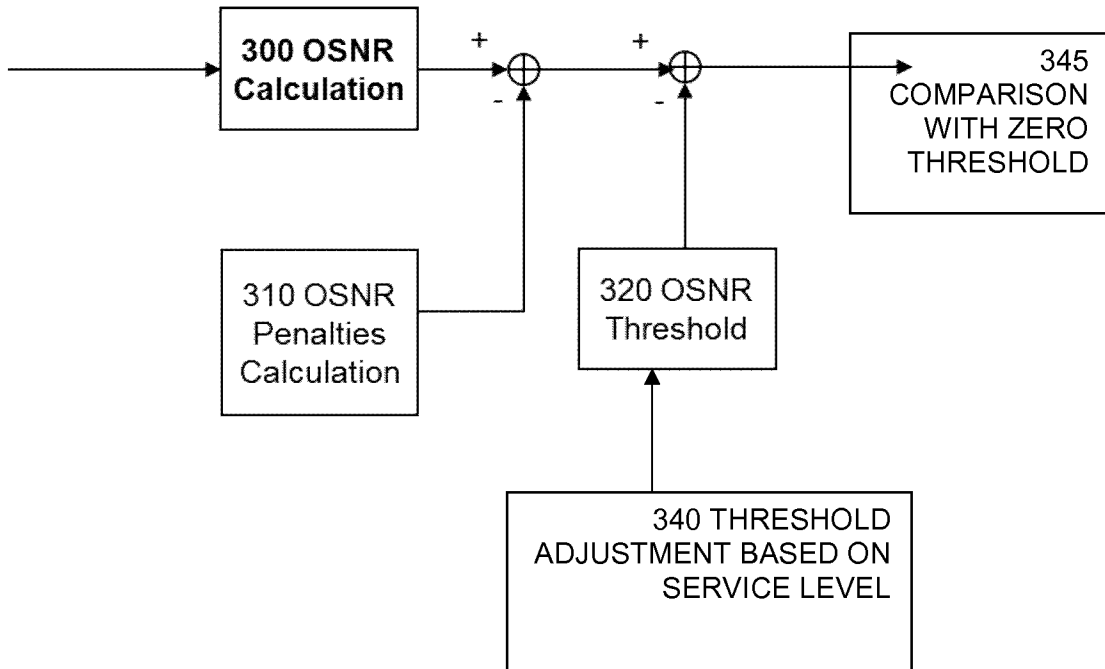

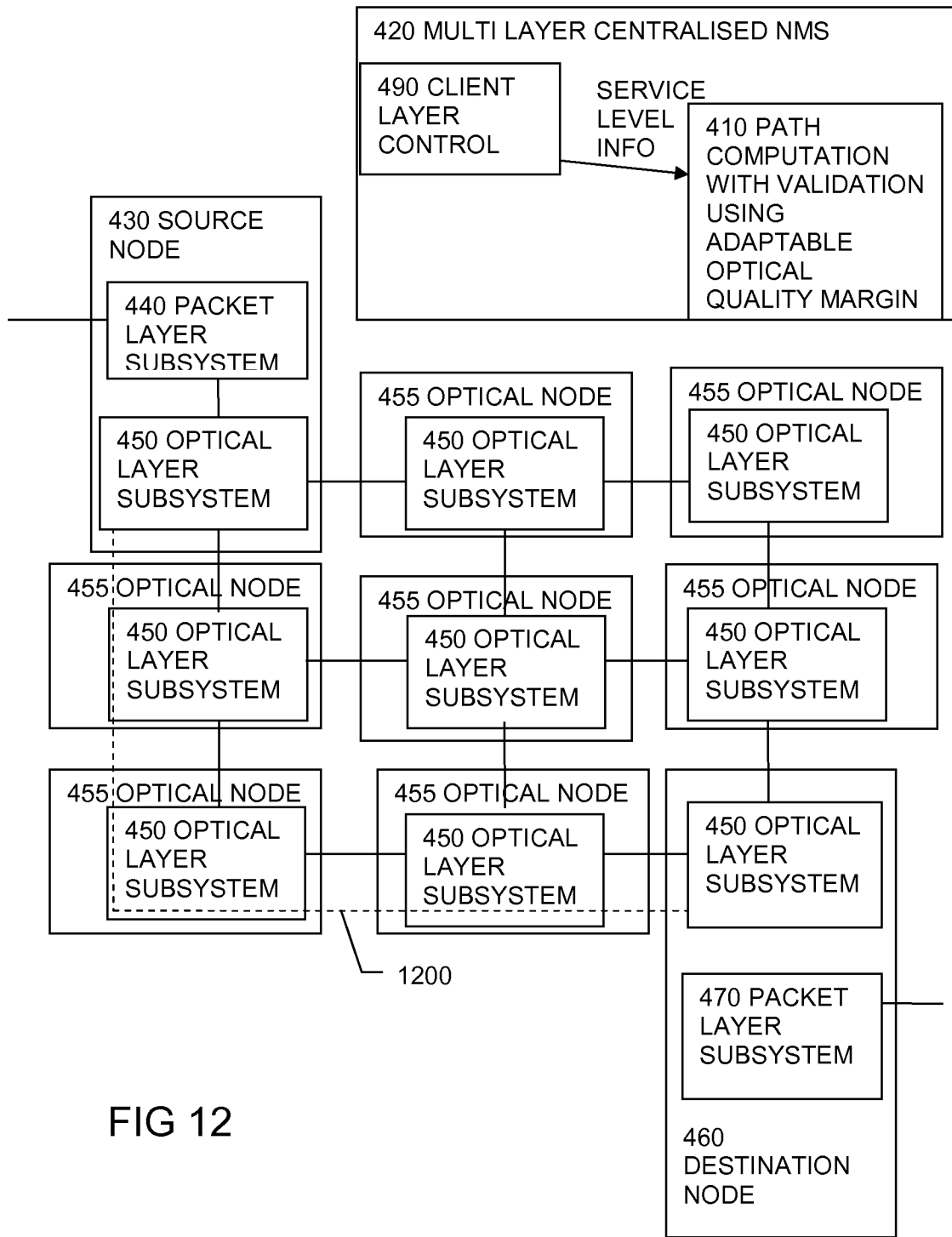
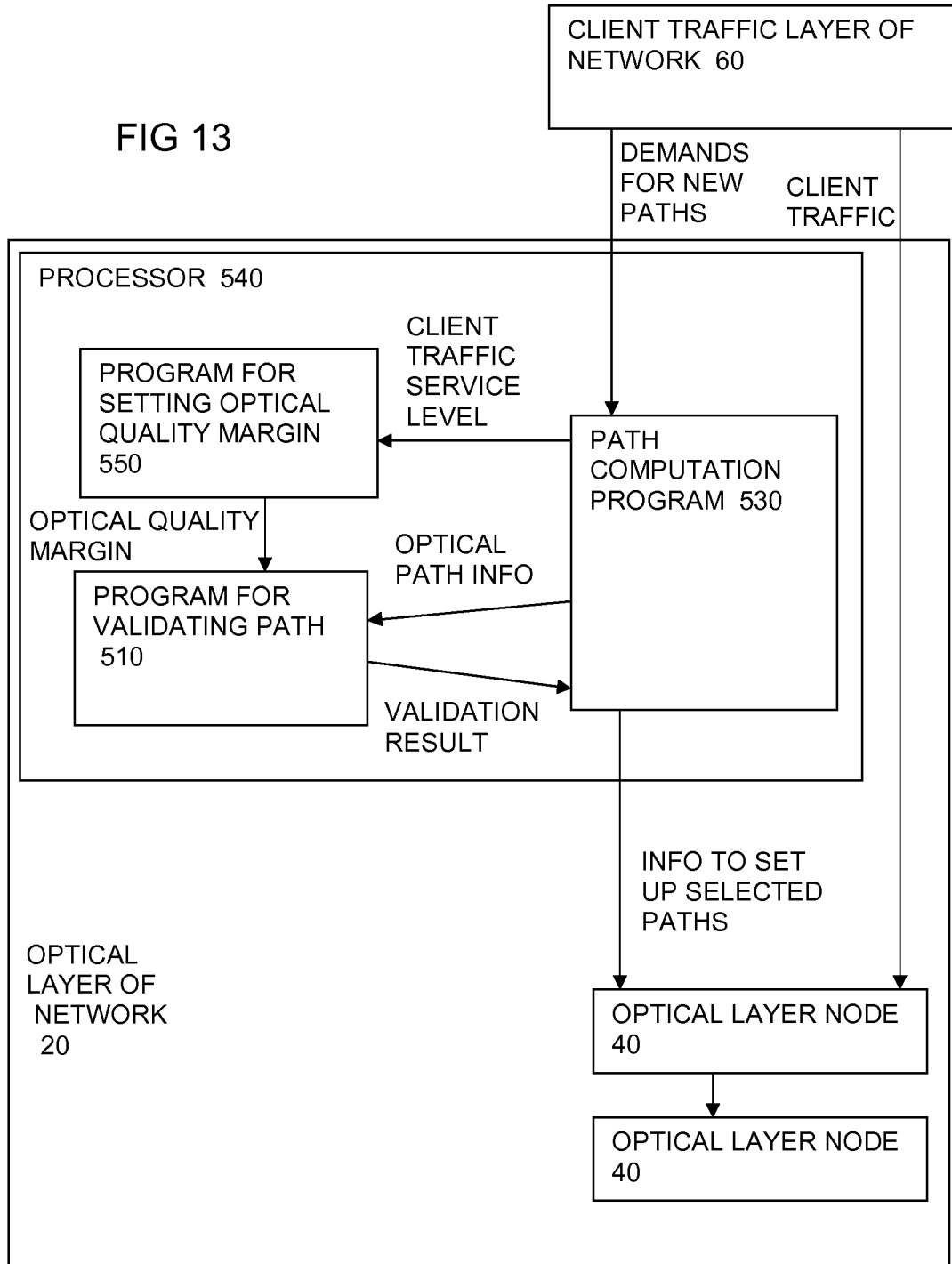

FIG 12

FIG 13



INTERNATIONAL SEARCH REPORT

International application No  
PCT/EP2012/069538

A. CLASSIFICATION OF SUBJECT MATTER  
INV. H04J14/02 H04Q11/00  
ADD.  
According to International Patent Classification (IPC) or to both national classification and IPC

B. FIELDS SEARCHED  
Minimum documentation searched (classification system followed by classification symbols)  
H04J H04Q

Documentation searched other than minimum documentation to the extent that such documents are included in the fields searched

Electronic data base consulted during the international search (name of data base and, where practicable, search terms used)  
EPO-Internal, INSPEC, WPI Data

C. DOCUMENTS CONSIDERED TO BE RELEVANT

Category*	Citation of document, with indication, where appropriate, of the relevant passages	Relevant to claim No.
A	WO 2007/024317 A2 (INTELLAMBDA SYSTEMS INC [US]; SADANANDA SANTOSH KUMAR [US]; LOOK CHRIS) 1 March 2007 (2007-03-01) abstract paragraph [0084] paragraph [0093] paragraph [0179] - paragraph [0184] ----- -/--	1-16

Further documents are listed in the continuation of Box C.

See patent family annex.

\* Special categories of cited documents :

<p>"A" document defining the general state of the art which is not considered to be of particular relevance</p> <p>"E" earlier application or patent but published on or after the international filing date</p> <p>"L" document which may throw doubts on priority claim(s) or which is cited to establish the publication date of another citation or other special reason (as specified)</p> <p>"O" document referring to an oral disclosure, use, exhibition or other means</p> <p>"P" document published prior to the international filing date but later than the priority date claimed</p>	<p>"T" later document published after the international filing date or priority date and not in conflict with the application but cited to understand the principle or theory underlying the invention</p> <p>"X" document of particular relevance; the claimed invention cannot be considered novel or cannot be considered to involve an inventive step when the document is taken alone</p> <p>"Y" document of particular relevance; the claimed invention cannot be considered to involve an inventive step when the document is combined with one or more other such documents, such combination being obvious to a person skilled in the art</p> <p>"&amp;" document member of the same patent family</p>
---	---

Date of the actual completion of the international search  28 June 2013	Date of mailing of the international search report  09/07/2013
---	--

Name and mailing address of the ISA/ European Patent Office, P.B. 5818 Patentlaan 2 NL - 2280 HV Rijswijk Tel. (+31-70) 340-2040, Fax: (+31-70) 340-3016	Authorized officer  Dhondt, Erik
--	--

## INTERNATIONAL SEARCH REPORT

International application No  
PCT/EP2012/069538

C(Continuation). DOCUMENTS CONSIDERED TO BE RELEVANT		
Category*	Citation of document, with indication, where appropriate, of the relevant passages	Relevant to claim No.
A	<p>LEE HUAWEI G BERNSTEIN GROTTO NETWORKING JONAS MARTENSSON ACREO T TAKEDA NTT T TSURITANI KDDI Y: "PCEP Extensions for WSON Impairments; draft-lee-pce-wson-impairments-02.txt", PCEP EXTENSIONS FOR WSON IMPAIRMENTS; DRAFT-LEE-PCE-WSON-IMPAIRMENTS-02.TXT, INTERNET ENGINEERING TASK FORCE, IETF; STANDARDWORKINGDRAFT, INTERNET SOCIETY (ISOC) 4, RUE DES FALAISES CH- 1205 GENEVA, SWITZERLAND, no. 2, 7 July 2011 (2011-07-07), pages 1-19, XP015077037, [retrieved on 2011-07-07] paragraph [02.1]</p> <p style="text-align: center;">-----</p>	1-16
A	<p>AYAN BANERJEE (CALIENT NETWORKS) ANGELA CHIU (CELION NETWORKS) JOHN DRAKE (CALIENT NETWORKS) DAN BLUMENTHAL (CALIENT NETWORKS) AND: "Impairment Constraints for Routing in All-Optical Networks; draft-banerjee-routing-impairments-00.txt" 20010301, 1 March 2001 (2001-03-01), XP015010606, ISSN: 0000-0004 paragraph [04.3]</p> <p style="text-align: center;">-----</p>	1-16
A	<p>EP 2 501 065 A1 (ERICSSON TELEFON AB L M [SE]) 19 September 2012 (2012-09-19) abstract</p> <p style="text-align: center;">-----</p>	1-16
A	<p>PAOLUCCI F ET AL: "Experimental Demonstration of Impairment-Aware PCE for Multi-Bit-Rate WSONs", IEEE/OSA JOURNAL OF OPTICAL COMMUNICATIONS AND NETWORKING, IEEE, USA, vol. 3, no. 8, 1 August 2011 (2011-08-01), pages 610-619, XP011360019, ISSN: 1943-0620, DOI: 10.1364/JOCN.3.000610 the whole document</p> <p style="text-align: center;">-----</p>	1-16

**INTERNATIONAL SEARCH REPORT**

Information on patent family members

International application No

PCT/EP2012/069538

Patent document cited in search report	Publication date	Patent family member(s)	Publication date	
WO 2007024317	A2	01-03-2007	EP 1900120 A2	19-03-2008
			US 2009304380 A1	10-12-2009
			US 2013039651 A1	14-02-2013
			WO 2007024317 A2	01-03-2007
-----				
EP 2501065	A1	19-09-2012	EP 2501065 A1	19-09-2012
			US 2012237207 A1	20-09-2012
			WO 2012123249 A1	20-09-2012
-----				