

E. THOMSON.  
MANIPULATION OF REFRACTORY MATERIAL.  
APPLICATION FILED AUG. 28, 1902.

2 SHEETS-SHEET 1.

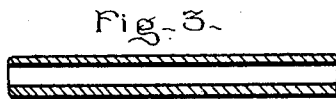
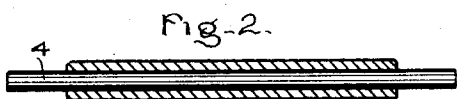
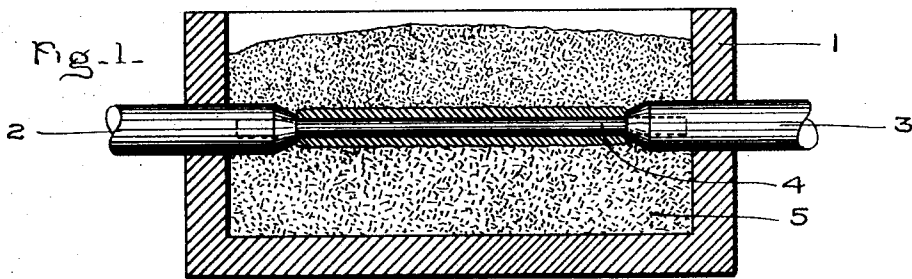

Fig. 5-

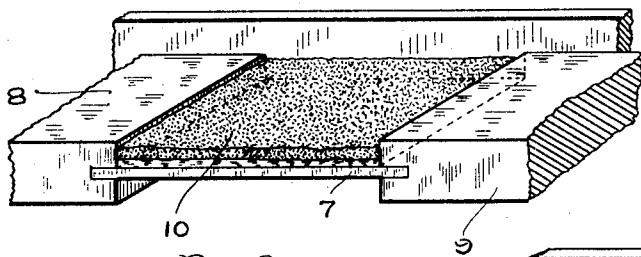
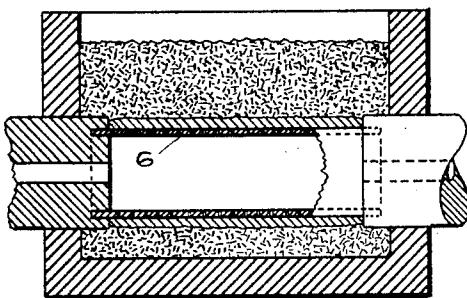

Fig. 6-

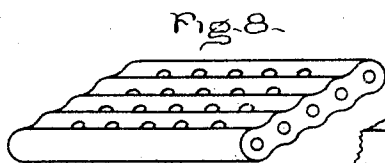

Fig. 8-

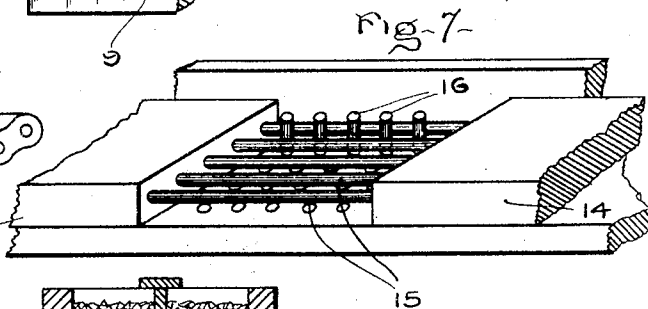
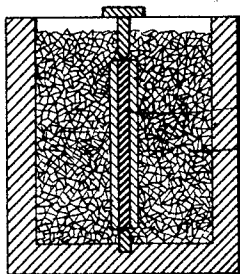

Fig. 7-

Fig. 9-



WITNESSES.

*George A. Thomson.*  
*Benjamin B. Hill.*

INVENTOR.

*Elihu Thomson.*

By *Albert S. Davis*

Att'y.

E. THOMSON.  
MANIPULATION OF REFRACTORY MATERIAL.

APPLICATION FILED AUG. 28, 1902.

2 SHEETS—SHEET 2.

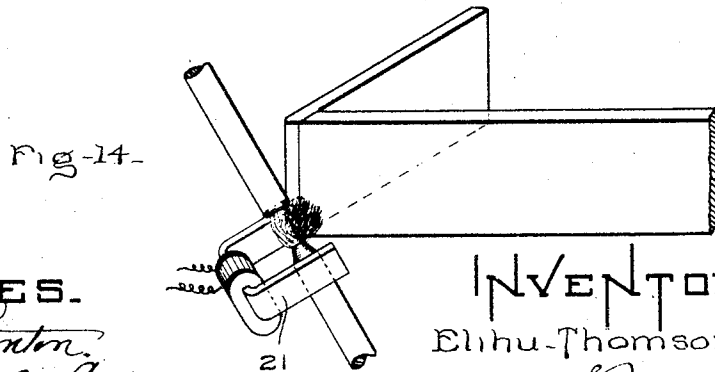
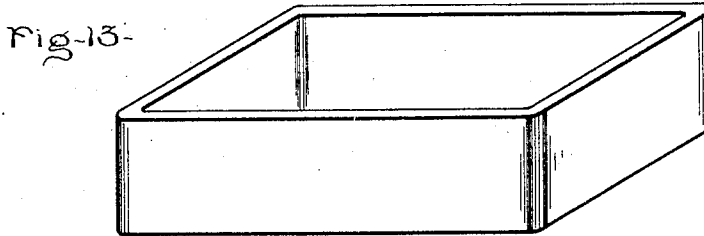
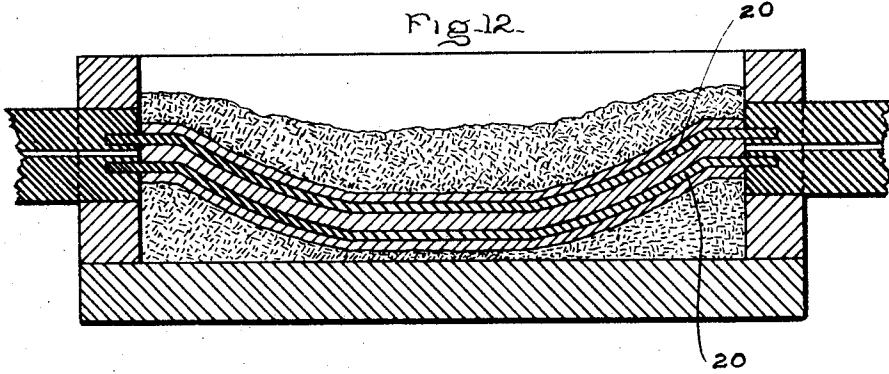
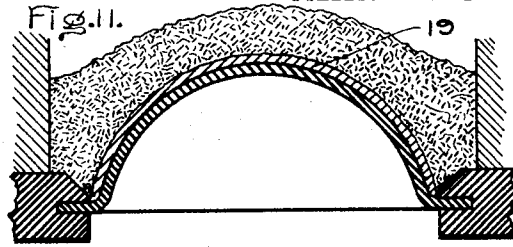
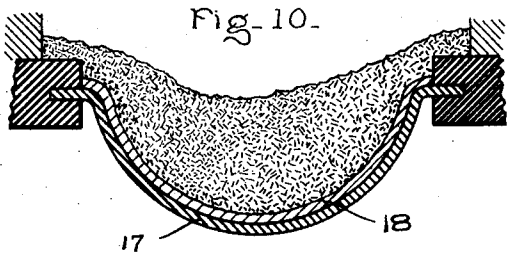

WITNESSES.

*George A. Thornton*  
*Benjamin B. Hill*

INVENTOR.  
Elihu Thomson.

By, *Amos D. ...*  
Atty.

# UNITED STATES PATENT OFFICE.

ELIHU THOMSON, OF SWAMPSCOTT, MASSACHUSETTS, ASSIGNOR TO  
GENERAL ELECTRIC COMPANY, A CORPORATION OF NEW YORK.

## MANIPULATION OF REFRACTORY MATERIAL.

SPECIFICATION forming part of Letters Patent No. 778,286, dated December 27, 1904.

Application filed August 28, 1902. Serial No. 121,322.

*To all whom it may concern:*

Be it known that I, ELIHU THOMSON, a citizen of the United States, residing at Swampscott, county of Essex, State of Massachusetts, have invented certain new and useful Improvements in the Manipulation of Refractory Material, of which the following is a specification.

My present invention relates to the formation of articles—such as tubes, plates, or more complex forms—out of refractory material, such as fused silica.

In carrying out my invention in practice I provide a refractory conductor, such as carbon, arranged to be traversed by a heavy electric current and adapted to be embedded in or surrounded by quartz granules or silica in comminuted form. Upon the passage of very strong heating-currents through the carbon conductor the quartz or other refractory material in the immediate vicinity of the conductor is melted, so that upon the cooling of the conductor a body of fused quartz following the contour of the conductor is formed. By choosing the shape and size of the conductor I find it possible to produce articles of fused quartz in a large variety of configurations.

The novel features which I believe constitute my invention I have set forth with particularity in the appended claims, while the invention itself I have described in detail in the following specification, which is to be taken in connection with the accompanying drawings, which represent various ways of carrying out my invention in practice.

In the drawings, Figure 1 shows a view, partly in section, of an arrangement for forming a tube from granular quartz. Figs. 2, 3, and 4 are views showing the result of the operation. Fig. 5 shows a modified arrangement particularly useful for the formation of tubes of comparatively large diameter. Fig. 6 represents the formation of a plain slab of silica. Figs. 7 and 8 show the formation of a more complex structure. Fig. 9 shows a means for the simultaneous formation by a single conductor of a plurality of slabs. Figs. 10, 11, and 12 show modifications of the arrangements noted, and Figs. 13 and 14 show

the method of building up vessels from the slabs formed by previous operations. 50

The practically non-expansibility of silica which has once undergone fusing is a property which enables the silica to be applied to many uses. It is difficult, however, to obtain the material in the various forms desired, and to render easier the production of these forms is among the objects of my present invention. 55

In Fig. 1 the raw material to be acted upon, which may either be ordinary quartz-sand or, if preferred, quartz which has previously been fused and then pulverized, is placed in a suitable retaining vessel 1, through the walls of which are passed terminals 2 3 of conducting material, such as metal. Between the ends of these terminals and making good contact with the ends of the terminals is mounted a rod 4, of carbon. By sending a very strong electric current through this rod it becomes intensely heated and causes fusion of the contiguous portions of the mass of granulated quartz or sand 5, in which the rod is embedded during operation. The length of time during which current is permitted to pass determines the depth to which the fusion takes place about the heating-rod, and therefore the thickness of the tube which results from the operation. After the heating has been continued for a suitable length of time the current is shut off and the apparatus is allowed to cool, after which the carbon rod with its inclosing coating of fused quartz, as represented in Fig. 2, is removed from the apparatus. The fused coating of quartz about the carbon rod generally does not adhere to the rod, so that the latter may be removed, thereby leaving a tube of quartz, as in Fig. 3. 60  
65  
70  
75  
80  
85

In case a curved instead of a straight tube is desired it is only necessary that the heating-rod should be curved to correspond. The curved rod after being heated in the manner above described becomes coated with fused quartz, thereby forming a curved tube, as in Fig. 4. When the heating-rod cannot be removed by mechanical withdrawal, it may be burned out by heating the whole to a high 90

temperature, but not sufficient, however, to soften the tube.

The exterior of the tube is of a more or less granular nature, dependent on the fineness of the granules used, but may be smoothed exteriorly by a subsequent heating in the electric arc progressively from end to end.

Where the tube to be formed is of relatively large diameter, I make the heating member tubular, as at 6 in Fig. 5, and this tube I provide with fine perforations, so as to permit the ready escape of gases generated during the operation of the apparatus. The openings or perforations in the tube permit the escape of gas which would otherwise injure the outline of the tube to be formed from the surrounding outer or granulated quartz, but are not sufficiently large to permit the granulated quartz to sift through into the heating-tube.

Where it is desired to form a slab or plate of fused quartz, I pursue a method substantially similar to that described. Instead, however, of a heating rod or tube I make use of a perforated plate 7, of carbon, joined to heavy terminals 8 and 9. Upon the face of this plate of carbon I place a layer of granular quartz 10 and then pass a heavy heating-current through the plate. A layer of fused quartz thereby results, and the thickness depends upon the length of time the current is permitted to pass through the heating-plate. After the mass has cooled the plate of fused quartz may be removed, and its outer surface, which consists of more or less imperfectly-fused quartz, may be treated in the electric arc in the manner already described in connection with the foregoing figures of the drawings.

In Fig. 9 the heating conductor or slab or carbon 11 instead of being mounted horizontally and quartz placed on its upper surface only is arranged vertically and completely surrounded by a mass of fused quartz 12. After heating the carbon plate or slab masses of fused quartz form on both sides of the slab, thereby forming two slabs simultaneously. As soon as the current is cut off the slabs chill and retain their form.

The formation of a somewhat more complicated structure is represented by Figs. 7 and 8, in which the main terminals are indicated at 13 and 14, between which terminals extend a plurality of heating-rods 15, of carbon. By enveloping these rods in granulated quartz and then pushing the heating operation until the quartz is fused to a sufficient depth a slab having a plurality of parallel openings there-through is formed, as indicated in Fig. 8. In case openings extending in any other direction or directions through the slab or mass are devised pieces of refractory material, such as carbon, may be inserted in place to act as cores, as indicated, for example, at 16. Where

it is desired that the slabs or plates of fused quartz shall have a curved or other irregular form, I correspondingly fashion the contour of the heating-conductor. Thus in Fig. 10 the heating-conductor, which may be of carbon, is curved downwardly, as shown, so that when heated portions of the granular quartz contiguous to the heating-conductor 17 become fused and upon cooling form a rigid mass with curved outline, as at 18.

Instead of carrying on the operation indicated in Fig. 10 with the heating-conductor bowed or curved downward the conductor may, if desired, be arranged so that its convex portion is upward. This portion being then covered with the granulated quartz is heated, thereby producing a curved sheet 19.

The arrangement shown in Fig. 12 differs from the arrangements shown in Figs. 10 and 11 only in that a plurality of curved heating-plates 20 are used, the plates being arranged side by side and producing after having been heated a plurality of correspondingly-shaped bodies of fused quartz located both on the outer sides of the plates and between the plates, as shown.

Fig. 13 represents a vessel formed from separately-produced slabs of fused quartz by the application of the electric arc in the manner indicated in Fig. 14. In this latter figure the edges of the plates are burned or fused together by the electric arc, which may be used somewhat in the manner of a blowpipe by utilizing the deflecting action of a magnetic field produced either by a permanent magnet or by a suitably-excited electromagnet, such as 21.

On account of the almost negligible expansion of the fused quartz there is no difficulty in fusing the separate parts together, for the heat may be applied as suddenly as desired without any danger of cracking or rupturing the material.

What I claim as new, and desire to secure by Letters Patent of the United States, is—

1. The method of forming articles out of quartz or analogous refractory material in a divided state, which consists in placing a mass of the material in contact with a highly-refractory conducting-body, passing a heating-current of electricity through said conducting-body so as to produce fusion of a portion or portions of the material nearest to the refractory body, then discontinuing the heating, and after the parts have cooled removing the fused mass from contact with the refractory body.

2. The method of producing tubes, plates or the like from quartz or analogous refractory material in a divided state, which consists in surrounding a refractory conducting-body having the desired contour with a quantity of the divided refractory material, heating said conducting-body so as to produce fusion of portions of the refractory material

in contact therewith, allowing the mass to cool, and then removing the fused refractory material from said body.

3. The method of forming articles out of quartz or analogous refractory material in a divided state, which consists in surrounding a highly-refractory conducting-body with such material, passing through said body an electric current of sufficient strength to heat up the body and produce fusion of that portion only of the surrounding refractory material nearest to the body, then discontinuing the heating, and after the parts have cooled removing the fused mass from contact with the heating-conductor.

4. The method of forming articles from

quartz in a divided state, which consists in partially surrounding a highly-refractory conducting-body with the quartz, generating heat electrically in said conducting-body such as to produce fusion of the quartz in contact therewith, then allowing the mass to cool and when cold separating the fused mass from the conducting-body without destroying the form imparted to the mass by said conducting-body.

In witness whereof I have hereunto set my hand this 26th day of August, 1902.

ELIHU THOMSON.

Witnesses:

DUGALD MCK. MCKILLOP,  
JOHN J. WALKER.