

(No Model.)

2 Sheets—Sheet 1.

# J. HEMPHILL & J. FAWELL. CRANE.

No. 489,634.

Patented Jan. 10, 1893.

FIG. 1.

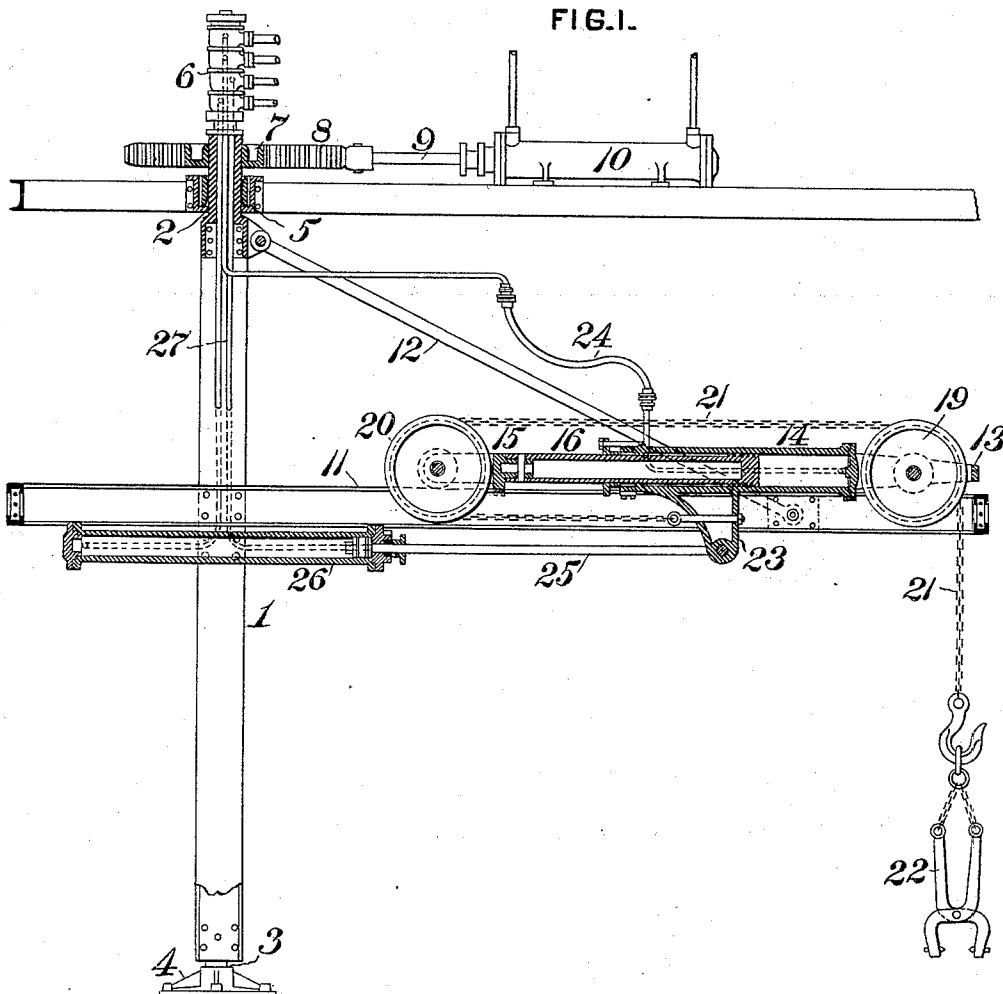
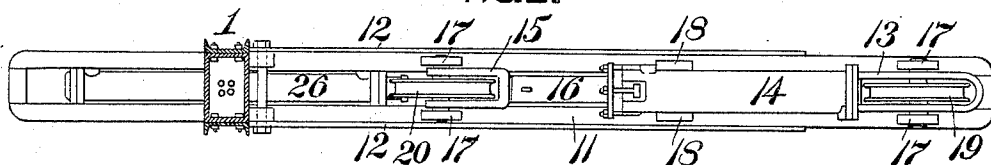

FIG. 2.



WITNESSES:

*Danron S. Wolcott*  
*F. E. Gaither*

INVENTORS:

*James Hemphill,*  
*Joseph Fawell,*  
by *George H. Christy*  
Att'y.

(No Model.)

2 Sheets—Sheet 2.

J. HEMPHILL & J. FAWELL.  
CRANE.

No. 489,634.

Patented Jan. 10, 1893.

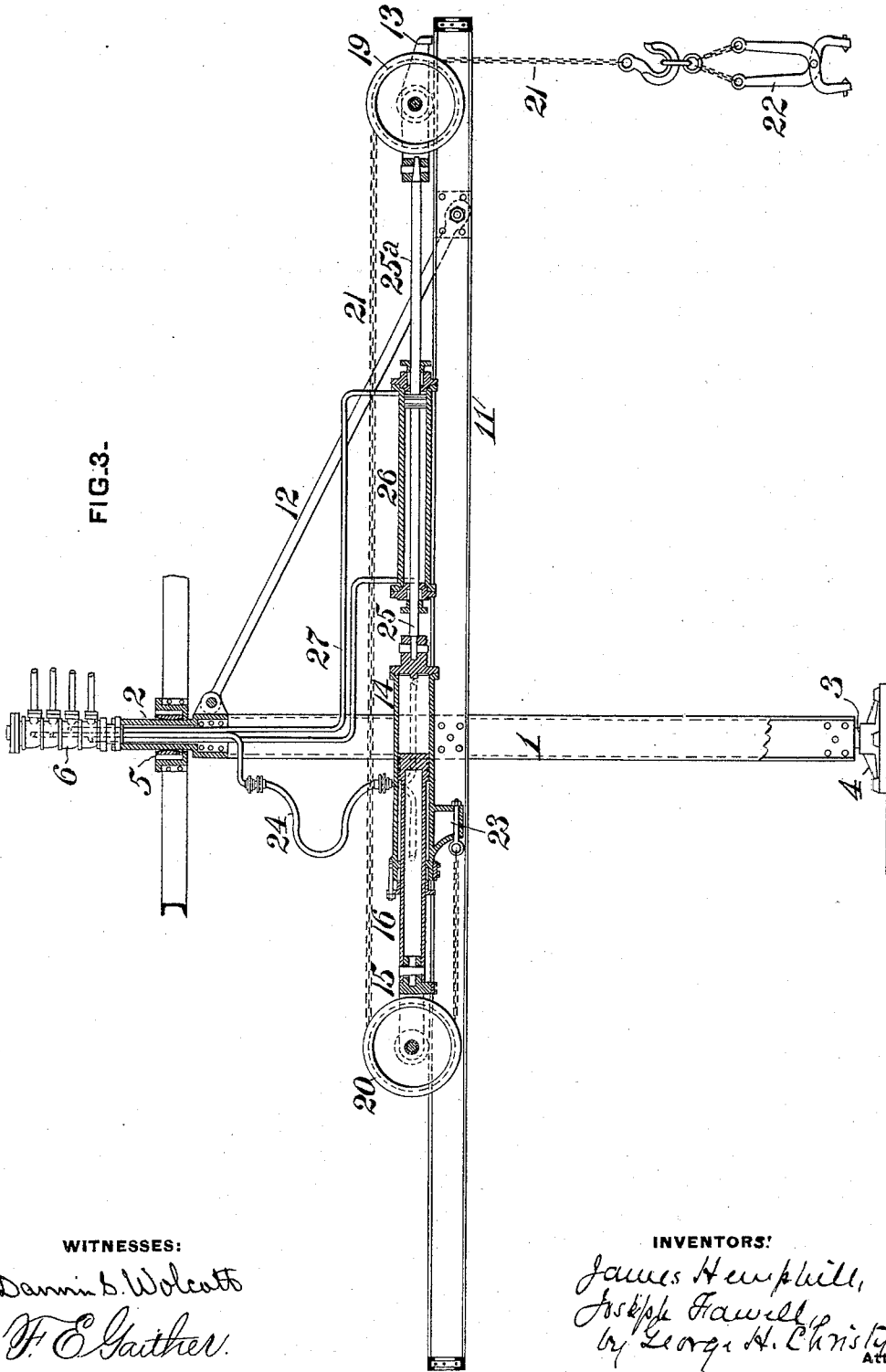

WITNESSES:

Davin S. Wolcott  
F. E. Gaither.

INVENTORS:

James Hemphill,  
Joseph Fawell,  
by George H. Christy  
Att'y.

# UNITED STATES PATENT OFFICE.

JAMES HEMPHILL AND JOSEPH FAWELL, OF PITTSBURG, PENNSYLVANIA.

## CRANE.

SPECIFICATION forming part of Letters Patent No. 489,634, dated January 10, 1893.

Application filed July 14, 1892. Serial No. 440,001. (No model.)

*To all whom it may concern:*

Be it known that we, JAMES HEMPHILL and JOSEPH FAWELL, citizens of the United States, residing at Pittsburg, in the county of Allegheny and State of Pennsylvania, have invented or discovered certain new and useful Improvements in Cranes, of which improvements the following is a specification.

The invention described herein relates to certain improvements in fluid pressure cranes. It has heretofore been customary in this class of cranes to effect the vertical movement of the load by means of a jib shifted vertically by a fluid pressure cylinder and piston located at or near the mast, or by a fluid pressure cylinder and piston arranged vertically on the jib of the mast. The former class of cranes are not applicable for low-roofed buildings where a comparatively large range of vertical movement is required, as it is necessary in order to obtain the desired lift to place the lower end of the mast with the lifting cylinder in a pit below the floor level. In the latter class only a small range of movement can be had, on account of the necessary limitation as to the length of the lifting cylinder.

The object of the present invention is to so construct and arrange the lifting mechanism as will render it possible to obtain a range of lift approximately equal to the height of the building in which the crane is placed.

In general terms the invention consists in the construction and combination substantially as hereinafter more fully described and claimed.

In the accompanying drawings forming a part of this specification, Figure 1 is a sectional elevation of a crane constructed in accordance with the present invention; Fig. 2 is a top plan view of the jib, the mast being shown in section, and; Fig. 3 is a view similar to Fig. 1, showing certain modifications in the arrangement of the cylinders on the jib.

In the practice of the invention, the mast 1 is constructed of channel-irons which are secured at their upper and lower ends to journals 2 and 3, the journal 3 being arranged in a suitable step 4, and the journal 2 mounted in a suitable bearing 5 secured to the upper frame work of the building. The upper end of the mast is provided with a fluid pressure distributing head 6 from which extend pipes

leading to the several fluid pressure cylinders as will be hereinafter described. On the upper journal 2 is fastened a gear wheel 7 intermeshing with a rack bar 8 connected to the piston 9 of the fluid pressure cylinder 10, employed for rotating the mast.

The jib 11 is formed of I beams bolted at or near their inner ends to the mast, their outer ends being supported by rods 12, extending down from the head of the mast. A frame 13 is secured or formed integral with one head of the fluid pressure cylinder 14, and a yoke 15 is secured to the end of the piston rod 16 of said cylinder. On the sides of the frame and yoke are mounted rollers 17, which together with wings 18 formed on the side of the cylinder rest upon the top of the beams forming the jib. In the frame 13 and yoke 15 are mounted wheels 19 and 20, over which passes a chain 21 having one end connecting to a gripping mechanism 22, and its opposite end secured to a lug 23 on the underside of the cylinder. Fluid pressure is introduced into the ends of the cylinder by pipes 24, which extend down from the distributing head 6. By admission of fluid pressure into one end and a corresponding exhaust from the opposite end of the cylinder the wheel 20 will be shifted and the gripping mechanism raised or lowered the distance of travel of the gripping mechanism being twice that of the wheel 20.

In order to control the movements of the lifting cylinder 14 during the raising or lowering a load, and also to shift said cylinder along the jib, the piston rod 25 of a second fluid pressure cylinder 26 is connected to the lifting cylinder as shown in Figs. 1 and 3. In the construction shown in Fig. 1, the shifting cylinder 26 is secured to the underside of the jib, and its piston rod is connected to the lug 23. If preferred, however, the lifting and shifting cylinder may be arranged as shown in Fig. 3. In this arrangement, the piston of the stationary shifting cylinder is provided with rods projecting through opposite ends of the cylinder. One of these rods as 25 is attached to the rear end of the lifting cylinder 14 and the frame 13 carrying the wheel 19 is shifted from the end of the lifting cylinder and attached to the end of the piston rod 25. It will be observed that the rods 25, 25<sup>a</sup>, form

a solid connection between the lifting cylinder and the frame, so that the cylinder and frame move together on the admission of fluid pressure to the shifting cylinder, as in the construction shown in Figs. 1 and 2.

Fluid pressure is conducted to the shifting cylinder by pipes 27 extending from the distributing head 6.

It will be readily understood that the jib 11 may be arranged very near the upper end of the mast, so that a lift nearly equal to the height of the building can be had. When the jib is arranged at or near the upper end of the mast, the rods 12 would be changed to compression rods by arranging them from the outer end of the jib to the lower end of the mast.

In other forms of fluid pressure cranes, a very large percentage of power is employed in lifting parts of the crane, but it is characteristic of our improved crane that the power is employed almost entirely in raising the load, and we are, therefore, enabled to effect a large economy in the amount of water or other fluid in raising a given load.

We claim herein as our invention:

1. In a crane, the combination of a jib, a movable fluid pressure cylinder mounted horizontally on said jib and a gripping mechanism having a flexible connection to said cylinder, substantially as set forth.

2. In a crane, the combination of a jib, a lifting cylinder mounted horizontally on said jib, and a stationary fluid pressure cylinder for shifting the lifting cylinder, substantially as set forth.

3. In a crane, the combination of a jib, a movable fluid pressure cylinder mounted horizontally on said jib, wheels movable with the piston rod of said cylinder and with the cyl-

inder respectively, and a flexible connection extending from the gripping mechanism around said wheels and connected to the cylinder, substantially as set forth.

4. In a crane, the combination of a jib, a fluid pressure cylinder mounted on said jib, wheels movable with the piston rod of said cylinder and with the cylinder respectively, a flexible connection extending from the gripping mechanism around said wheels and connected to the cylinder, and means for shifting said cylinder along the jib, substantially as set forth.

5. In a crane, the combination of a jib, a fluid pressure cylinder mounted on said jib, wheels movable with the piston of said cylinder and with the cylinder respectively, a flexible connection extending from the gripping mechanism around said wheels and connected to the cylinder, and a stationary fluid pressure cylinder secured to the jib for shifting the lifting cylinder, substantially as set forth.

6. In a crane, the combination of a jib, a lifting cylinder mounted on said jib, a shifting cylinder having a piston rod connected to the lifting cylinder, wheels mounted on the ends of the piston rods of the lifting and shifting cylinders, respectively, and a flexible connection extending from a gripping mechanism around said wheels and connected to the lifting cylinder, substantially as set forth.

In testimony whereof we have hereunto set our hands.

JAMES HEMPHILL.  
JOSEPH FAWELL.

Witnesses:

R. H. WHITTLESEY,  
DARWIN S. WOLCOTT.