

*J. Nicolai,
Folding Chair,*

N^o 107,708.

Patented Sep. 27, 1870.

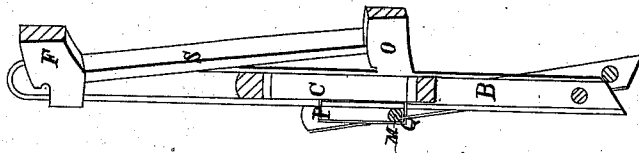

Fig. 2.

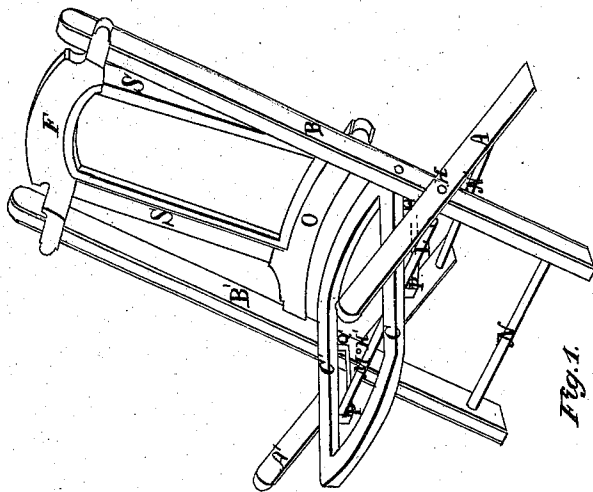

Fig. 1.

Witnesses.

*Frank G. Parker.
Arthur Berry*

Inventor.

J. Nicolai

United States Patent Office.

JULIUS NICOLAI, OF BOSTON, MASSACHUSETTS.

Letters Patent No. 107,708, dated September 27, 1870.

IMPROVEMENT IN FOLDING-CHAIRS.

The Schedule referred to in these Letters Patent and making part of the same.

To all whom it may concern:

Be it known that I, JULIUS NICOLAI, of Boston, in the county of Suffolk and State of Massachusetts, have invented certain new and useful Improvements in Folding-Chairs; and I do hereby declare that the following is a full and exact description thereof, reference being had to the accompanying drawings and to the letters of reference marked thereon.

My invention relates particularly to an improvement in that class of folding-chairs described in United States Letters Patent No. 71,445, granted to me, each chair having crossing legs, or leg-frames, and a hinged back, all folding together into substantially one plane.

In my present chair the parts are made to simultaneously fold in the same, or substantially the same manner as is shown in the folding-chair patented by myself and Philip J. Rinn, October 26, 1869, No. 96,139, and my improvement is shown in the accompanying drawings as embodied upon such Nicolai and Rinn chair, said improvement consisting in combining the frame formed by the extension of one pair of the legs with an auxiliary quadrangular frame, the vertical bars of which are placed between the vertical bars of the main frame, and in an angular plane relatively thereto, while the top and bottom bars are placed, the former in front and the latter in rear of the main frame, this auxiliary frame, when upholstered, constituting the most easy and practical back-rest that can be applied to these chairs.

In the Nicolai and Rinn chair, shown in their patent, No. 96,139, this auxiliary frame is not employed, the upholstery being fastened to top and bottom cross-bars and the main frame-pieces, but such construction is defective, and the objections to it are entirely obviated by my improvement.

In the drawings—

Figure 1 is a perspective view of my chair open ready for an occupant.

Figure 2 is a section of my chair as it appears folded.

I construct my chair as follows:

B B', fig. 1, form the back and two legs, and are framed together by means of a rung, N, and the cross-pieces O and F, the upper cross-bar F being attached

to the front of the pieces B B', while the lower cross-bar O is attached to the back.

The object of thus attaching the cross-bars O and F is to give the back of the chair a more desirable angle than would be obtained if both cross-bars were attached to the same side of the pieces B B'.

A A' are two pieces forming the rear legs of a chair and part of the arms, being connected together by means of a rung, N', at the lower extremities, and a rung, L M, near the upper extremities.

The parts A A' are connected to the parts B B' by the pivots H H'.

O C' represent the frame of the seat of the chair, and is hinged, as shown in fig. 1, to the parts B B', and being otherwise supported, when the chair is open, by the rung L M.

P Q and P' Q', figs. 1 and 2, are strong loops, made of suitable material, and attached to the under side of the seat, as shown in the drawings, so that the rung L M passes through the loops thus formed.

By this arrangement the legs A A' and seat O C' both move together.

The outer ends P P' of the loops form a convenient stop for the rung L M, and give suitable rigidity to the chair.

The parts so described constitute the Nicolai and Rinn chair, and in my improvement, as shown in the drawings, I extend, from each side of the upper cross-bar F to the corresponding side of the lower cross-bar O, a vertical bar, S, the two bars F O and the two bars S S making a strong and rigid frame, properly adapted, when upholstered, to support the back of the occupant of the chair in a comfortable and healthy position.

I claim—

In combination with folding cross-legs or frames and a folding-seat, a back-frame, F O, S S, when arranged relatively to the parts B B', substantially as shown and described.

J. NICOLAI.

Witnesses:

FRANK G. PARKER,
A. HUN BERRY.