

No. 785,437.

PATENTED MAR. 21, 1905.

C. H. REPATH & F. E. MARCY.
ROASTING FURNACE.

APPLICATION FILED MAY 9, 1904.

3 SHEETS—SHEET 1.

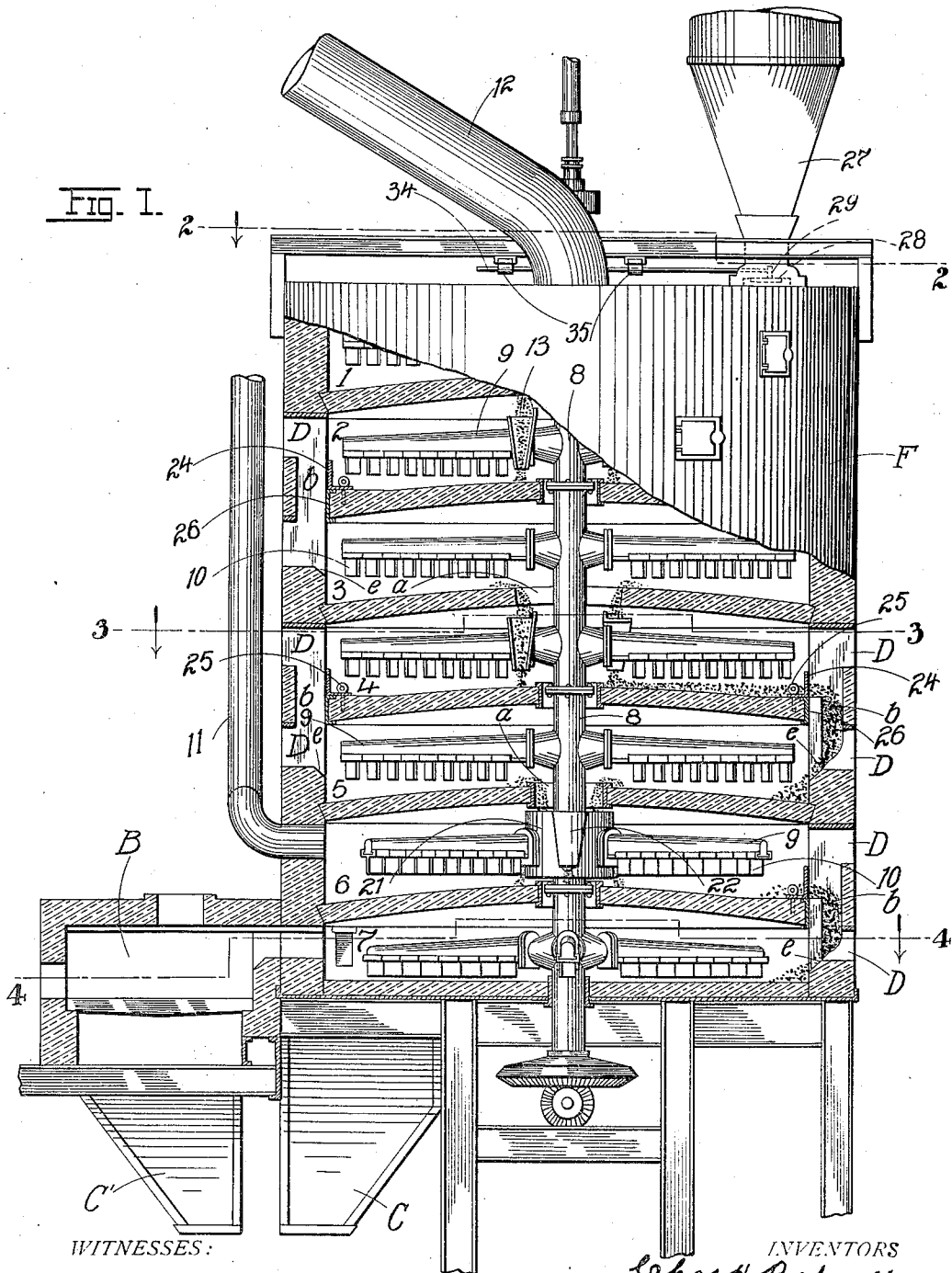

WITNESSES:

Thos. J. Dawy
M. D. Whitecomb

INVENTORS

Chas. H. Repath
Frank E. Marcy

BY

Edw. J. Carey

ATTORNEY.

No. 785,437.

PATENTED MAR. 21, 1905.

C. H. REPATH & F. E. MARCY.
ROASTING FURNACE.

APPLICATION FILED MAY 9, 1904.

3 SHEETS—SHEET 2.

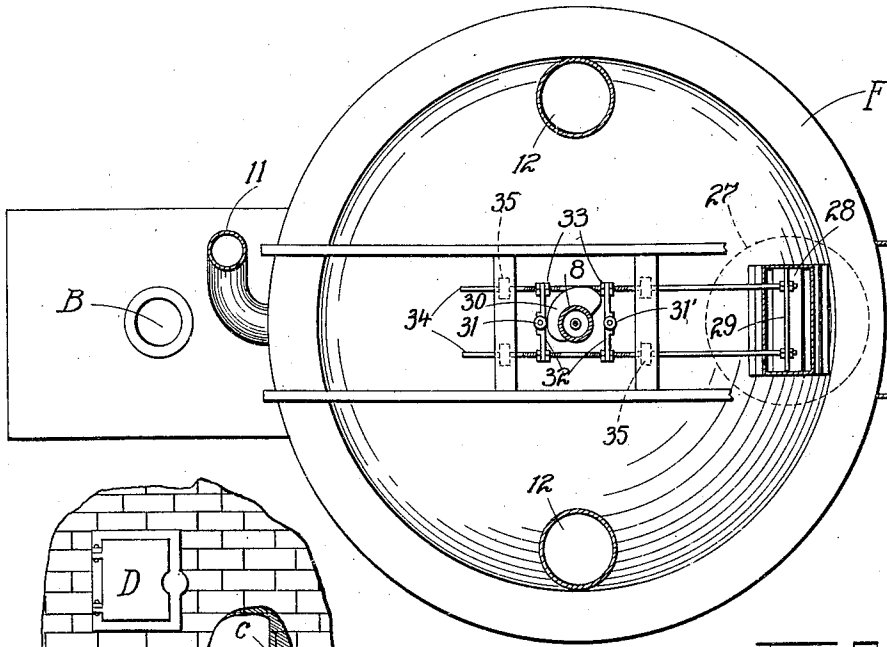

FIG. 2.

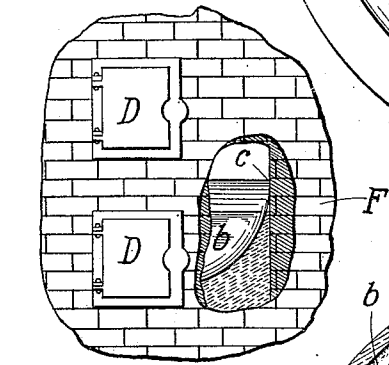

FIG. 3.

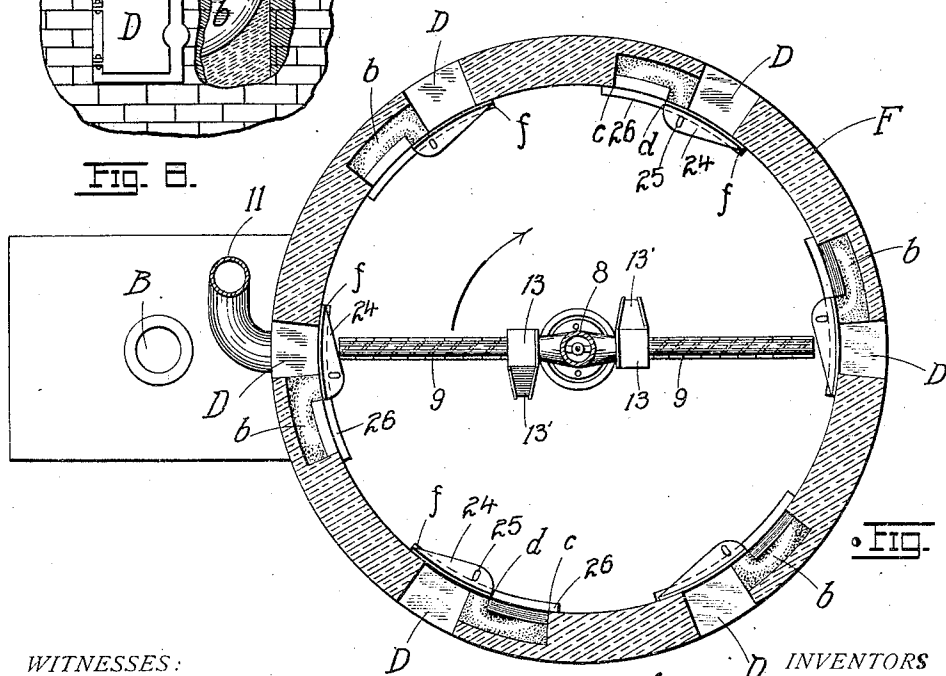

FIG. 4.

WITNESSES:

W. J. Rawson
M. D. Whitcomb

INVENTORS
Chas. H. Repath
BY Frank E. Marcy
Ernst Searen
ATTORNEY.

C. H. REPATH & F. E. MARCY.

ROASTING FURNACE.

APPLICATION FILED MAY 9, 1904.

Fig. 4.

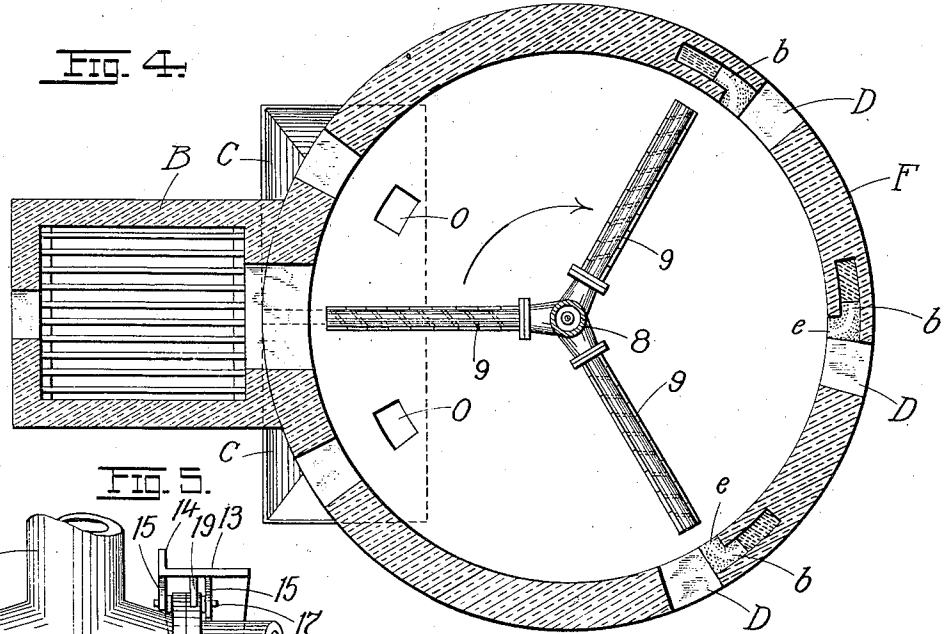

Fig. 5.

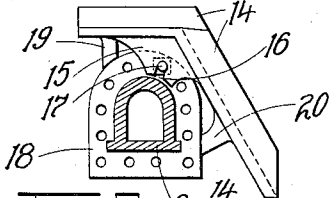
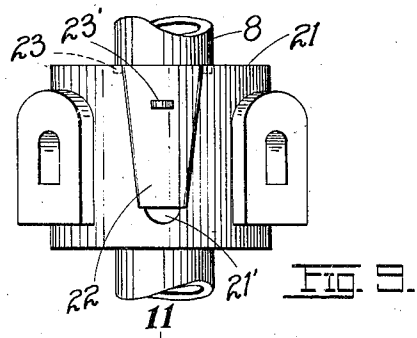
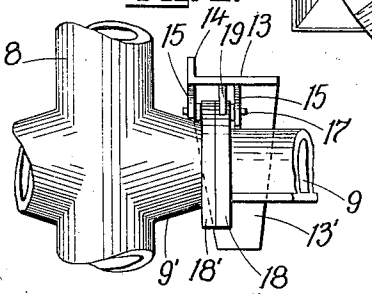

Fig. 8.

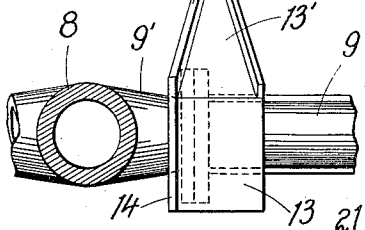

Fig. 7.

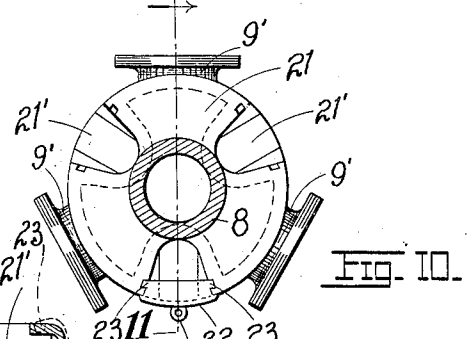

Fig. 10.

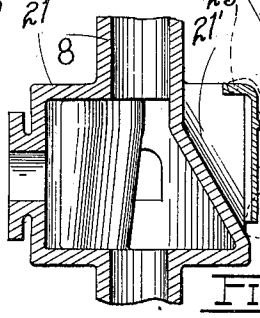

Fig. 11.

WITNESSES:

W. J. Sawyer
M. D. Whitcomb

INVENTORS

Chas. A. Repath
Frank E. Marcy
Emil Sauer
 ATTORNEY.

UNITED STATES PATENT OFFICE.

CHARLES H. REPATH AND FRANK E. MARCY, OF NEW YORK, N. Y., AS-
SIGNORS TO FRANK KLEPETKO, OF NEW YORK, N. Y.

ROASTING-FURNACE.

SPECIFICATION forming part of Letters Patent No. 785,437, dated March 21, 1905.

Application filed May 9, 1904. Serial No. 207,105.

To all whom it may concern:

Be it known that we, CHARLES H. REPATH and FRANK E. MARCY, citizens of the United States, residing at New York, in the county of New York and State of New York, have invented certain new and useful Improvements in Roasting-Furnaces, of which the following is a full, clear, and exact description, reference being had to the accompanying drawings, forming a part hereof.

Our invention has relation to improvements in roasting-furnaces; and it consists in the novel arrangement and combination of parts more fully set forth in the specification and pointed out in the claims.

In the drawings, Figure 1 is a combined vertical section and elevation of the furnace, the plane of section being taken through the middle of the fire-box. Fig. 2 is a top plan and part section on the line 2 2 of Fig. 1. Fig. 3 is a horizontal section on line 3 3 of Fig. 1. Fig. 4 is a horizontal section on the line 4 4 of Fig. 1. Fig. 5 is a detail showing a rear elevation of the ore-conveying shield. Fig. 6 is a side elevation thereof. Fig. 7 is a top plan thereof. Fig. 8 is a detail showing a section of the furnace in elevation with portion of the wall removed to show the inclined bottom of the marginal discharge-openings which conduct the ore from one hearth to the next hearth beneath. Fig. 9 is a detail showing an elevation of the diverted-draft ore-conveying shield. Fig. 10 is a top plan thereof, and Fig. 11 is a vertical section on line 11 11 of Fig. 10.

The present improvements are directed to the general class of roasting-furnaces known as the "McDougall" or "turret" type, the purpose thereof being to so qualify the details of this type as to make it specially adapted for the roasting of zinc-blende with a view not only of converting the ore into the form of oxid, but also with a view of preventing any loss thereof and with a further view of saving the sulfurous anhydrid formed in the roasting operation. It is to be understood, however, that the furnace need not necessarily be restricted to the roasting of zinc-blendes, the novel features thereof being capable of

adoption to any furnace where it would be advantageous to do so. The aim in zinc-roasting is to convert the sulfid into the oxid, and to accomplish this the ore must be fine, (or about such as will pass through a six-mesh screen,) the temperature high, and the roasting must be slow and careful with frequent stirring. Of course it is never economical to effect a complete elimination of the sulfur; but in good practice to reduce the amount combined with the zinc, iron, and lead to at least one per cent. for every part, by weight, of sulfur remaining in the ore means approximately two parts of zinc that are lost in the subsequent metallurgical process that follows. The reaction that takes place may be expressed as follows:

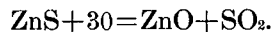

The sulfurous anhydrid escapes partly as such; but by catalysis a portion is converted into sulfuric anhydrid, which combining with the zinc oxid forms the neutral sulfate of zinc. The latter at a red heat is decomposed into basic sulfate and sulfuric anhydrid, thus,

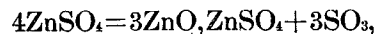

the sulfuric anhydrid being in turn split up into sulfurous anhydrid and oxygen. The basic zinc sulfate is not decomposed until after a preliminary roasting by the aid of external heat, which must be sufficient to bring the ore up to a bright red heat. This decomposition of course has reference also to the elimination of the normal sulfate constituent by conversion thereof into oxid, thus,



and this is one of the several objects which our present furnace is designed to accomplish.

A further object of our present invention is to prevent the exposure of the ore (especially the fine particles thereof) to the upward draft of the gases disengaged during the roasting operation, it being well known that such upward draft will carry the fine particles with it and in time entail a considerable loss of ore. In the present instance this is accomplished by causing the ore to slide from one hearth to

the next hearth below instead of being permitted to drop through space and encounter the upward draft referred to. In a generic sense this idea of permitting the ore to slide is not new, dust-preventing devices having been described by us in United States Patent No. 740,589, issued to us under date of October 6, 1903, such devices being there shown in the form of spouts and annular rotatable shields. Yet with these the ore is more or less precipitated and does not slide as gradually as in our present furnace. With our present improvement, too, the ore as it slides from one hearth to the one next below is initially conducted in the direction in which it is raked after being once deposited on said hearth—that is to say, in dropping from a centrally-discharging hearth the ore slides away from the axis of rotation of the stirring-shaft, (either radially outward from said axis or at right angles to the radius of the cross-section of the shaft,) thereby starting in its course toward the outer margin of the hearth which discharges at such margin, and in dropping from a marginal-discharging hearth the ore slides toward the shaft or toward the center of the hearth discharging at such center. In this way the rakes which direct the ore in proper direction on the hearths during the stirring operation are materially assisted, and congestion of ore at either the center or margin is avoided.

Other advantages flowing from our present construction will be apparent from a detailed description of the invention, which is as follows:

Referring to the drawings, F represents the furnace, and 1 2 3 4 5 6 7 the several hearths in which the material is treated, the ore dropping from the upper hearth successively through the several hearths until it is delivered into the discharge-hoppers C C, (through openings O O on one side of the bottom hearth,) the hearths being provided, respectively, with central and marginal openings or apertures *a b* for the passage of the material. Passing centrally through the hearths is the rotatable hollow stirring-shaft 8, from which radiate the series of superposed hollow rabble-arms 9, extending into the several hearths and carrying rakes or blades 10, by which the material is stirred and successively fed from one hearth to the hearth immediately beneath it, all as fully understood in furnaces of the McDougall type. In the present case we provide the sixth and seventh hearths with three rabble-arms each, (there being but two in each of the remaining hearths,) whereby we increase the stirring, at the same time giving the ore a greater travel along the path of the rakes. We are thus able to discharge the ore on one side of the furnace rather than by the six marginal openings *b* set at sixty degrees apart, as on the hearths 2 and 4. The two lower hearths are supplied with heat

from a fire-box B, from which the ashes drop into a hopper C', the products of combustion from said fire-box passing through hearths 7 and 6 (see arrows, Fig. 1) and out through a flue 11, leading from the sixth hearth. The purpose of the fire-box is to effect the secondary roasting which splits up the basic sulfates that are formed on the upper hearths. The probable reactions by which this splitting up or decomposition is effected has been indicated above. The sulfurous anhydrid (SO₂) escapes through the flues 12 from the top of the furnace, being saved and subsequently utilized for the manufacture of sulfuric acid or for any available purpose. The stirring-shaft and rabble-arms are preferably water-cooled, as in our patent above referred to. Starting from the upper hearth the ore is discharged centrally therefrom onto the second hearth, then from the margin of the second hearth onto the third hearth, then centrally from the third hearth onto the fourth hearth, and so on, as clearly seen from the drawings, when it is finally raked into the discharge-hoppers C C. As was stated above, the ore in the present instance slides from one hearth to the hearth next beneath it, and on hearths 2 and 4 we mount at the base of the rabble-arms, immediately under the centrally-discharging openings *a*, leading from the hearths above, the shields, which not only serve to conduct the ore from the hearth above in a continuous and uninterrupted path, but permitting the top layers of sliding ore to indirectly protect the under layers or fines from the upward draft, Fig. 1. These shields and their manner of attachment to the rabble-arms may be described as follows: Each shield is composed of a horizontally-disposed platform or initial ore-depositing surface 13, from which extends downward an inclined portion 13', the ore being first deposited on the platform or surface 13 and piling up as high as the hearth from which it is delivered. Fig. 1, thereby giving a continuous path for the ore to slide to the next hearth below. The ore after leaving the platform 13 slides down the incline 13', the inner edges of both the platform and incline and the outer edge of the incline being provided with upwardly-projecting flanges 14 to prevent the ore from falling over the edge of the shield. The shield is provided with cast-iron hooks 15, whose recesses 16 engage the opposite projecting ends of the extended bolt 17, the latter constituting one of the series of bolts by which the basal flange 18 of the rabble-arm is coupled to the flange 18' of the stub-arm 9' of the stirring-shaft. This extended bolt, with the aid of the supports 19 and 20, formed, respectively, with the parts 13 and 13', gives a method by which the shield becomes secure, the same being readily removable without the necessity of first closing and cooling the furnace. This shield might of course be a

double one (the one shown here being single)—that is, there could be an inclined portion 13' on each side of the rabble-arm; but this would be of no advantage, as the ore would always slide on one side or the other, and therefore it is only necessary to increase the area of the platform 13 and the ore will always go in one direction. From the drawings it is apparent that the general dip of the inclines 13' is away from the axis of the stirring-shaft and in a vertical plane disposed at right angles to the radius of the cross-section of said shaft.

The shield above described is admirably adapted for the purpose for which the same is intended in the relation the same occupies in the furnace; but in the sixth hearth a qualified form of shield must be employed, one which while permitting the calcines to slide from the fifth hearth will at the same time serve to divert the courses of the products of combustion from the fire-box into the flue 11, so as to prevent these products mixing with the SO₂ gases passing upward through the first five hearths. This diverted draft-shield 21 is in the shape of a (preferably) cylindrical enlargement of the water-cooled stirring-shaft, the rabble-arms being carried directly thereby. It is in the nature of a chamber or drum through which the water freely circulates, and between the stub-arms 9' thereof the peripheral walls are formed into a series of inclined planes or sections 21', leading radially outward and serving to conduct the ore from the fifth to the sixth hearth, the ore being previously deposited on top of the drum and piling up into the opening *a* leading from the fifth hearth, thereby making the passage of the ore from the fifth to the sixth hearth continuous, Fig. 1. Pivotaly swung from the top of the drum opposite the inclined sections 21' are aprons 22, which are free to swing outward, and thus allow large lumps and broken rakes to pass down the inclines, Fig. 11. The aprons are swung on trunnions 23, resting in suitable bearings or depressions formed on top of the drum. This shield 21 thus permits the calcines to slide down into the sixth hearth, at the same time diverting the draft into the smoke-flue 11, as already explained. Each apron is provided with a perforated lug 23' for the insertion of the hooked end of a rod by which the aprons can be readily lifted out of the furnace while hot and in a similar manner replaced.

The marginal openings *b* in the present furnace are located not in the floor separating two adjacent hearths, (as in the majority of furnaces of this type,) but are preferably formed in the body of the outer peripheral wall or casing of the furnace. These openings *b* are located, preferably, opposite to the doors D for practical and economic reasons. They are made much larger than ore-discharg-

ing openings in the standard furnace, so as to diminish the velocity of the gases passing through them, thereby reducing the percentage of loss of fine particles of ore carried upward mechanically by such rising currents.

The intake end of the opening *b* is confined between the points *c* *d*, the ore entering between these points and sliding down the inclined bottom of the opening, Fig. 3, which bottom conforms to the general peripheral curvature of the furnace-casing, after which the ore slides down the inwardly-directed discharge end *e* of such bottom, there to be received by the next hearth beneath and subsequently raked to the center of the latter hearth. Between the point *d* and the end of the opening opposite the point *c* is inserted a cast-iron shield or plate 24, by which the ore is prevented from falling into the opening until after it has come opposite the points *c* and *d*. The plate 24 is held in place by resting against the brickwork at the point *f*, Fig. 3, the base thereof being secured by a pin 25. This shield or plate can be readily replaced through the adjacent door D. The arch is supported by the cast-iron member 26 and special brick. Thus whether the ore descends through a central or marginal discharge-opening it slides down in a continuous stream from one hearth to the next hearth beneath until it is finally raked into the hoppers below the bottom hearth.

The feed mechanism while not distinctively new may be briefly adverted to as follows: It consists of a hopper 27, having tapering sides forming a rectangular-shaped bottom in which there is a cast-iron plate 28, which nearly closes the hopper. Upon this plate there rests a rake 29. The ore is fed into the furnace by the reciprocating movement of this rake over the plate, whereby the ore is discharged over the edge of the latter and falls into the furnace. The rake is reciprocated by the cam 30, which is revolved by the stirring-shaft. As this cam rotates it pushes the roller 31 until it reaches the end of its stroke, when it again pushes the roller 31', and thus the rake is moved back and forth with each revolution of the shaft. In order to regulate the amount of feed, it is only necessary to spread the cross-supports 32 to variable distances apart by unscrewing or screwing the nuts 33 on the tie-rods 34. The tie-rods are held in place by guides 35, as shown.

To such other parts of the present furnace as may be shown no specific reference is herein made, as they are either well known in the art or covered by prior patents.

We may of course qualify the present construction in minor details without in any wise affecting the nature or spirit of our invention.

Having described our invention, what we claim is—

1. In a furnace having a plurality of superposed hearths, means for conducting the ma-

terial from one hearth to the next hearth below in such manner that there is always an uninterrupted body of material connecting the material on one hearth with that on the next adjacent hearth, substantially as set forth.

2. In a furnace having a series of superposed hearths discharging their contents successively into one another, means for conducting said contents in a continuous uninterrupted body throughout the series of hearths, whereby the material on one hearth is connected by a body of material with the material on the next adjacent hearth, substantially as set forth.

3. In a furnace having a series of superposed hearths having means for discharging their contents alternately centrally and marginally into one another, means for conducting the contents in such manner that there is always an uninterrupted body of material connecting the material on one hearth with that of the next adjacent hearth, substantially as set forth.

4. In a furnace having a series of superposed hearths discharging their contents alternately at the center and at the margin into one another, and suitable shields located in alternate hearths below the central discharging-openings of the hearths immediately above for conducting the contents during such discharge from said upper hearths in an unbroken body to the hearths beneath, substantially as set forth.

5. In a furnace having superposed hearths apertured for the passage of the ore, means for crowding the ore toward the apertures, in combination with shields having initial depositing-surfaces, and inclined ways for the subsequent passage of the ore adapted to direct the ore on its way from one hearth to the next hearth below in such a manner as to protect the ore from the influence of the draft, substantially as set forth.

6. In a furnace having superposed hearths apertured for the passage of the ore, means for crowding the ore toward the apertures, in combination with rotating shields having surfaces for the initial deposit of the ore, and inclined ways for the subsequent passage of the ore adapted to direct the ore on its way from one hearth to the next hearth below in such manner as to protect the ore from the influence of the draft, substantially as set forth.

7. In a furnace having superposed hearths apertured for the passage of the ore, means for crowding the ore toward the apertures, in combination with rotating shields having horizontal surfaces for the initial deposit of the ore and inclined ways for the subsequent passage of the ore adapted to direct the ore on its way from one hearth to the next hearth below in such manner as to protect the ore from the influence of the draft, substantially as set forth.

8. In a furnace having superposed hearths apertured for the passage of the ore, means

for crowding the ore toward the apertures, in combination with shields adapted to direct the ore from one hearth to the next hearth below outwardly from the center or axis of the furnace, substantially as set forth.

9. In a furnace having superposed hearths, a suitable ore-conveying shield having an upper platform or initial depositing-surface, and an inclined portion for directing the ore from the initial depositing-surface over the hearth below, substantially as set forth.

10. In a furnace having superposed hearths apertured for the passage of the ore, a central stirring-shaft passing through the several hearths, rabble-arms carried by the shaft and extending into the several hearths, and ore-conveying shields coupled to the shaft below the apertures and having each a platform or surface for the initial deposit of the ore, and an inclined portion dipping away from the axis of the shaft and in a vertical plane at right angles to the radius of the cross-section of the shaft, for conducting the ore from one hearth to the next hearth below, substantially as set forth.

11. In a furnace having a series of superposed hearths discharging their contents one into the other, an independent fire-box discharging its products of combustion into the bottom hearth of the series, a draft-diverting and ore-conveying shield located in a hearth above the bottom hearth, and means for conducting the products thus diverted out of the hearth in which the shield is located, substantially as set forth.

12. In a furnace having superposed hearths apertured for the passage of the ore, means for crowding the ore toward the apertures, an independent fire-box for the bottom hearth, in combination with a shield located in a hearth above the bottom hearth for directing the ore from one hearth to the next hearth below, and simultaneously diverting the products of combustion from the fire-box into a discharge opening or flue leading from the hearth containing said shield, substantially as set forth.

13. In a furnace having superposed hearths adapted to alternately discharge centrally and marginally into one another, a central hollow stirring-shaft passing through the several hearths, rabble-arms carried by the shaft and extending into the several hearths, an independent fire-box for the bottom hearth, a shield or drum forming an enlargement of the shaft located in a hearth above the bottom hearth and below an upper centrally-discharging hearth, said drum having inclined peripheral sections for conveying the ore discharging through the adjacent central aperture of the hearth above, and outwardly-swinging aprons mounted on the drum in front of said inclined peripheral sections, the hearth containing said drum being adapted to discharge the products of combustion from the fire-box, substantially as set forth.

14. In a furnace having superposed hearths, a suitable draft-diverting and ore-conveying drum having an upper or initial depositing-surface, a series of inclined peripheral sections for conducting the ore radially outward from the axis of the furnace from one hearth to the next hearth below, and aprons pivoted to the drum in front of the inclined sections, and adapted to swing outwardly therefrom, substantially as set forth.

15. In a furnace, a draft-diverting and ore-conveying shield comprising a rotatable drum, having outwardly-inclined peripheral sections, and an initial depositing-surface to which said inclined sections lead, substantially as set forth.

16. In a furnace having a series of superposed hearths alternately discharging centrally and marginally into one another, the marginal openings or apertures being located in and conforming in general contour to that of the outer peripheral wall of the furnace, substantially as set forth.

17. In a furnace having superposed hearths apertured marginally for the passage of the ore, the said apertures being located within the outer wall of the furnace and having contours following substantially the contour of said outer wall, and having bottoms inclining from one hearth to the next hearth below, substantially as set forth.

18. In a furnace having superposed hearths

apertured marginally for the passage of the ore, said apertures following substantially the contour of the outer wall of the furnace, and a shield or plate located along a portion of the inner edges of the apertures, and terminating at points adjacent to the intake ends thereof for preventing the ore falling thereinto before reaching said intake, substantially as set forth.

19. In a furnace having superposed hearths apertured marginally for the passage of the ore, said apertures having bottoms following substantially the contour of the outer wall of the furnace, said bottoms inclining inwardly and downwardly from the intake end to the discharge end of such aperture, substantially as set forth.

20. In a furnace having superposed hearths apertured centrally and marginally for the passage of the ore, the central apertures directing the ore away from the center of the furnace, and the marginal apertures initially directing it toward the center, substantially as set forth.

In testimony whereof we affix our signatures in presence of two witnesses.

CHARLES H. REPATH.
FRANK E. MARCY.

Witnesses:

M. A. PESTANA,
M. E. RUTLEDGE.