

C. A. LIEB.  
EMBOSSING AND PRINTING PRESS.

No. 452,016.

Patented May 12, 1891.

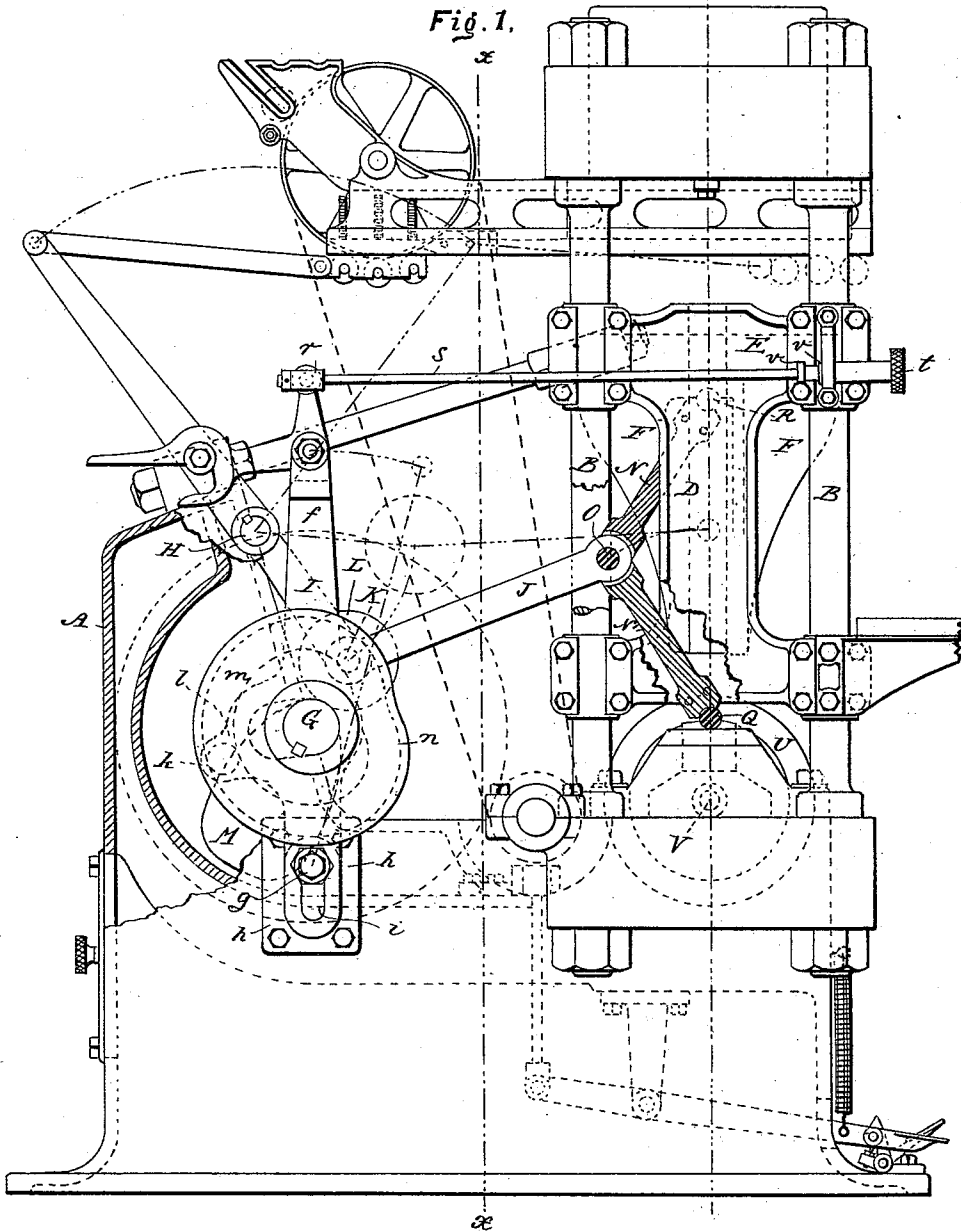

WITNESSES:

*W. A. Hilcox.*  
*D. C. Neusch.*

INVENTOR

*Charles A Lieb*  
BY *Phillip Abbott*  
his ATTORNEY.

(No Model.)

4 Sheets—Sheet 2.

C. A. LIEB.  
EMBOSSING AND PRINTING PRESS.

No. 452,016.

Patented May 12, 1891.

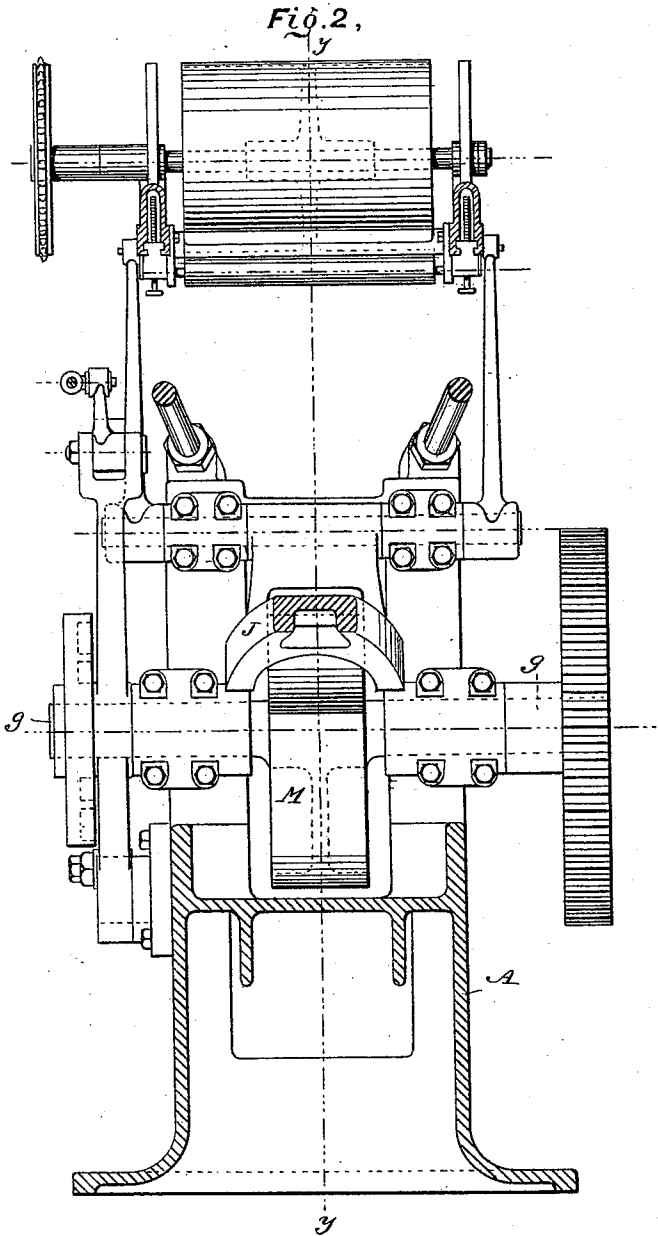

WITNESSES:

*H. H. Hilcox,*  
*D. C. Reusch.*

INVENTOR

*Charles A. Lieb*  
BY *Phillips Abbott*  
his ATTORNEY.

(No Model.)

4 Sheets—Sheet 3.

C. A. LIEB.  
EMBOSSING AND PRINTING PRESS.

No. 452,016.

Patented May 12, 1891.

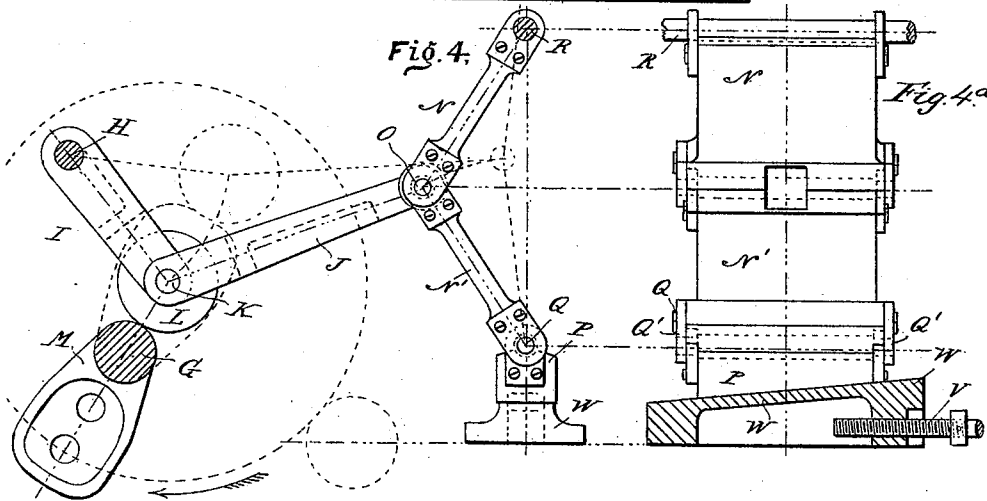
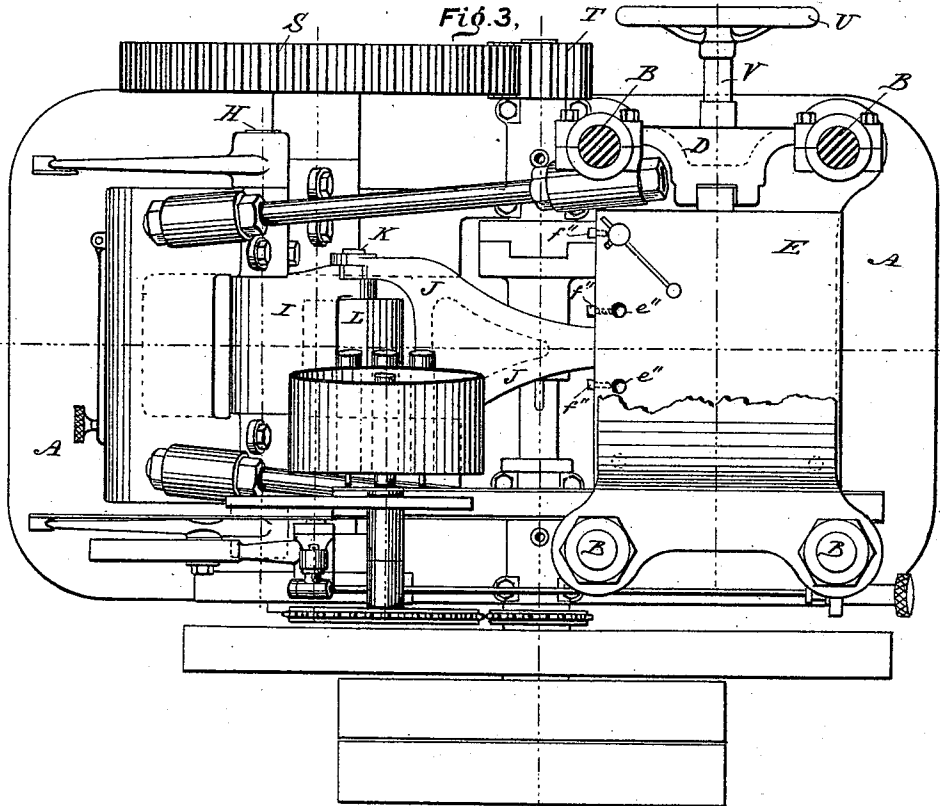

WITNESSES:  
*H. O. Niles.*  
*D. C. Reusch.*

INVENTOR  
*Charles A. Lieb*  
 BY  
*Phillips Abbott*  
 his ATTORNEY.

C. A. LIEB.  
EMBOSSING AND PRINTING PRESS.

No. 452,016.

Patented May 12, 1891.

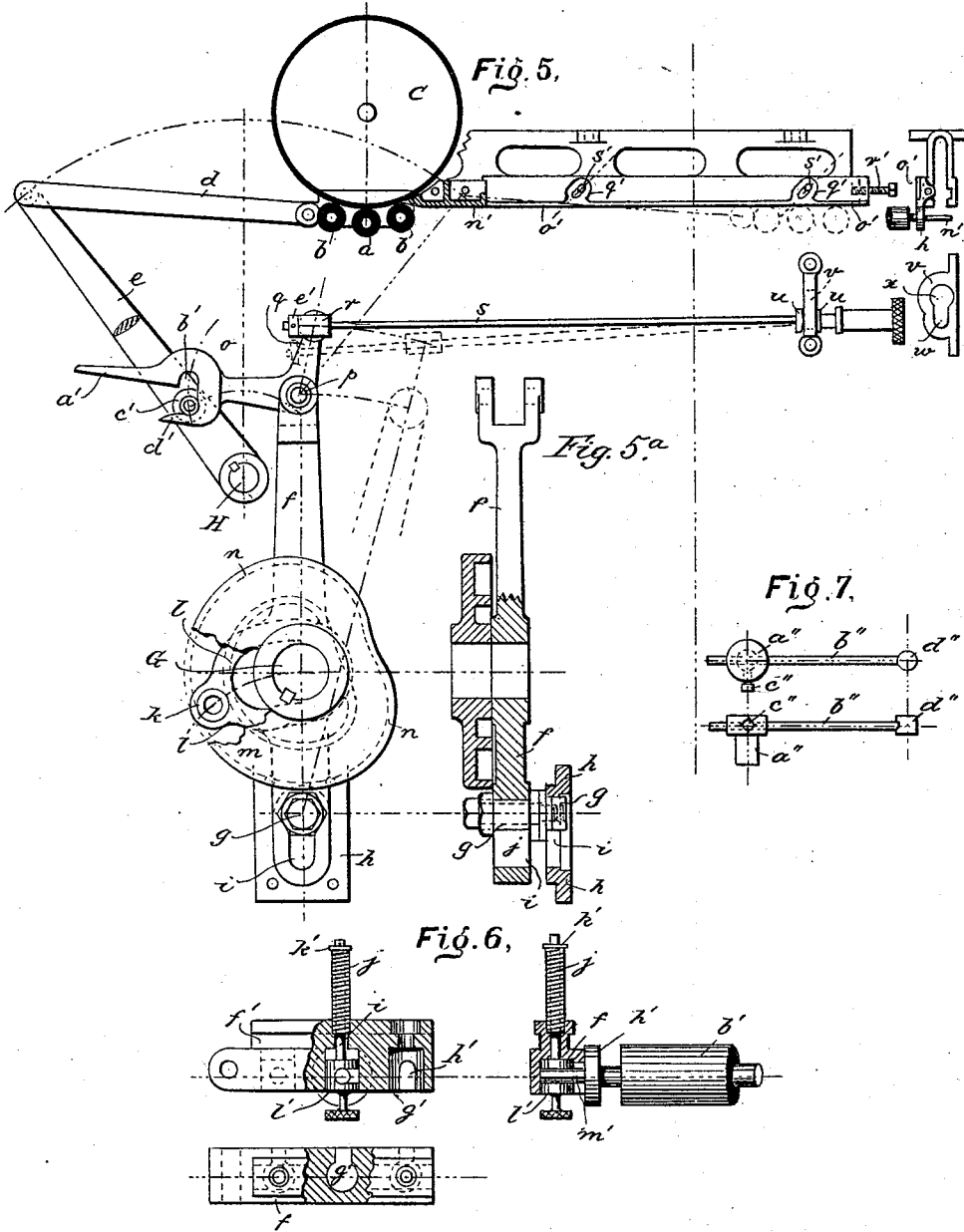

WITNESSES:

*W. H. Phelps*  
*D. C. Reusch*

INVENTOR

*Charles A. Lieb*  
BY *Phillips Abbott*  
his ATTORNEY.

# UNITED STATES PATENT OFFICE.

CHARLES A. LIEB, OF NEW YORK, N. Y.

## EMBOSSING AND PRINTING PRESS.

SPECIFICATION forming part of Letters Patent No. 452,016, dated May 12, 1891.

Application filed May 22, 1890. Serial No. 352,812. (No model.)

*To all whom it may concern:*

Be it known that I, CHARLES A. LIEB, a citizen of the United States, and a resident of New York, in the county of New York and State of New York, have invented certain new and useful Improvements in Embossing and Printing Presses, of which the following is a specification.

My invention relates to improvements in embossing and inking presses, my improved machine being adapted either to embossing alone or to printing alone or to embossing and printing, and it has special reference to the mechanical features which I hereinafter specifically describe and illustrate.

Referring to the drawings hereof, the same reference-letters indicate the same parts in all the figures.

Figure 1 is an elevation, partly in section, of the machine. Fig. 2 is a vertical section on the line  $x x$  of Fig. 1. Fig. 3 is a plan view, partly in section, partly broken away. Fig. 4 is a detail side view of the toggles which operate the platen and the cam upon which operates the toggles fixed upon the main driving-shaft. Fig. 4<sup>a</sup> is a front view of the toggles and toggle-elevating wedge, the latter being shown in section. Fig. 5 is a detail view of the inking mechanism. Fig. 5<sup>a</sup> is a front view of the lever which actuates the inking devices. Fig. 6 illustrates a detail, partly in section, of the ink-rollers, their journals, and carriage. Fig. 7 is a side and top view, respectively, of the platen-gages.

A A is the base to the machine. It is shown as a single casting. It is made of such form and material as preferred, and may be supported and strengthened by ribs, trusses, &c., cast integral with it or otherwise, as may be desired.

B B are upright posts or rods on which the head of the press is supported, and upon which the slideways C and the platen-guides D are also supported.

E is the platen.

F are slideways at both sides of the platen, whereby it is supported and in which it slides.

G is the main driving-shaft, which is driven in any preferred manner.

H is the shaft, to which the toggles hereinafter to be described are attached.

I is one arm of the first toggle, which is pivoted to the second arm J by pin K, and on pin K is a friction-roller L, which engages with a cam M on the shaft G, as shown.

N N' are the two toggle-arms of the second toggle, which directly actuate the platen. They are pivoted together and to one end of the toggle-arm J by a pin O. The lower end of the toggle-arm N' is pivoted to a wedge-block by a pin Q. This toggle is preferably prevented from lateral movement by two plates Q' at each side of the block P. The upper end of the upper toggle N is pivoted to the under side of the platen E in any suitable manner, as by a pin R, and I prefer to make the connection between these toggle-arms and the under side of the platen and the upper side of the wedge-block, respectively, in such manner that the toggles cannot pull away from those parts.

S is the main driving-wheel, which is keyed on the cam-shaft G, which meshes into a pinion T, which receives power from any suitable source.

U is a hand-wheel set on a spindle V, which is threaded, as shown in Fig. 4<sup>a</sup>, and W is an elevating-wedge, through a threaded hole, in which the end of the spindle V works. Thus when the hand-wheel is turned in one direction this wedge W will be moved forward, and vice versa. The wedge W, as seen in Fig. 4, supports the wedge-block P, upon which rests the toggles and platen, and when the wedge W is forced inwardly the block P is elevated. Thus in the operation of the machine in a manner well understood I am enabled to secure a vertical adjustment of the platen as desired. I call attention to a very important fact relating to this wedge. Heretofore wedges have been employed to vertically adjust toggles and platen or a platen alone, as the case may be, but always, as I believe, so arranged that it slid crosswise of the toggle-arm with which it engaged, and not as I show it in line with the pin Q of the toggles. (See Fig. 4<sup>a</sup>.)

Referring now to the inking apparatus and having special reference to Figs. 1, 5, and 6, a is the carriage upon which the rollers b are carried. c is the ink-distributing drum. d is the connecting-rod, which connects the ink-roller carriage with an arm e, which is keyed

at its lower end upon a shaft H. *f* is an arm which is pivoted at its lower end to a threaded stud *g*, which is adjustably attached to a plate *h*, which is bolted to the base of the machine. This plate *h* is slotted at *i*, and the lower end of the arm *f* is likewise slotted, as at *j*. By this means I secure a sort of double adjustment of the arm *f*, so that its throw may be very materially increased or diminished, for reasons hereinafter set forth. *k* is a cam-roller which is fastened to a lateral extension *l* of the arm *f*. This roller engages with and works in a groove *m*, made in a cam *n* on the shaft G. This cam *n* may be made in any preferred manner to give such movement to the lever *f*, and consequently to its coating parts, as may be desired, and it is not at all essential that it should be of the precise form or contour that I show in the drawings hereof; also, as is well understood, the cam *n* may be made adjustable in various ways, so that its throw may be regulated as desired. In this way, in fact, I may, if preferred, do away with the lever *f* entirely, the lever *e* being extended to engage directly with the cam *n*, suitable throw-off devices being, of course, supplied. *o* is a throw-off lever. It is pivoted at *p* to the upper end of the lever *f*, and has a bell-crank extension *q*, to the upper part of which is pivoted a swivel-socket *r*, through which extends a rod *s*, which has upon its end a handle *t*, and adjacent to its end there are collars *u u*, which engage with a casting *v*, which is fastened to some suitable part of the frame. The collars *u u* lock the rod *s*, and consequently the throw-off *q*, in such position as may be desired, depending upon whether the one or the other of the collars *u u* engages with a locking-slot *w*, formed in the casting *v*. The upper portion *x* of this slot is made of such a size as to allow the collars *u u* to pass through. The throw-off lever *o* has a forwardly-projecting finger *a'*, and is provided at the base of the finger with a locking slot or notch *b'*. *c'* is a roller pivoted to the lever *e*. *d'* is a lip extending forwardly from the throw-off lever *o* in a manner similar to the finger *a'*. *e'* is a nut on the forward end of the rod *s*. The operation of this part of the apparatus is as follows: The shaft G supports the cam *n*, and the roller *k* actuates the lever *f*, the throw of which, whether greater or less, will depend upon the adjustment of the pin *g* in the slots *i* and *j* of the casting or plate *h* and the lever *f*, and it is likewise evident that the difference in the movement of the lever *f* will be only in increased or diminished forward movement, and that its initial point will always be the same. Further, that when the throw-off *o* engages with the roller *c'* by reason of its resting in the locking-notch *b'* then the levers *e* and *d* and the ink-roller carriage will all partake of the motion of the lever *f*, and the ink-rollers will be carried forward and back under the die type or stamp, which is fastened to the under side of

the head, and that the stroke or distance of travel of the carriage may be accurately adjusted by the adjustment of the lever *f*, already explained; also, if the lever *s* be pulled out and the locking-collars *u u* be engaged with the locking-casting *v* in such manner as to break connection between the throw-off and the roller or pin *c'*, that then there will be no movement of the inking-carriage.

In Fig. 6 I show an improved means by which I journal the inking-rollers in the inking-carriage. *f'* are the sides of the carriage. A cylindrical recess *g'* is drilled into them from the under side with a slot *h'* cut through them laterally into the recess *g'*. *i'* is the spindle provided with a retracting-spring *j'*, there being a washer *k'* or its equivalent at the upper end of the spindle, and on the spindle is fastened a slotted block *l'*, which conforms substantially to the recess *g'* and is adapted to be pulled down out of the recess *g'*, thus exposing the slot in it below the side *f'* of the carriage. *m'* is a shaft upon which the inking-roller is placed. It is obvious that upon pulling down the spindle *i'* the block *l'* will descend with it, thus exposing the slot in the block, and that the end of the shaft *m'* of the ink-roller may then be inserted in the slot in the block, and that on letting go of the spindle the shaft will be carried up through the slot *h'* in the side rail of the carriage, and that the two slots will then hold the shaft in position. By these means I can easily and quickly insert or remove the ink-rollers. The recess *g'* and block *l'* both being cylindrical results in much economy in manufacture and much more smooth movement of the parts, jamming, which is liable to occur when square blocks are used, being avoided, because they can rotate in their sockets to conform to non-alignment or springing in the roller-shafts.

Referring now to Fig. 5, *n'* is a little table across the under side of which the ink-rollers pass after leaving the drum C. This breaks up the line of roughened ink left upon the ink-rollers consequent upon their separation from the drum C. *o'* are the rails fastened to the under side of the head of the press, upon which the ink-rollers are guided, and along which little wheels *p'*, set on the shafts *m'* of the ink-rollers, roll. These rails *o'* are adjusted up and down, as desired, by slotted ears *q'*, which are integral with the rails, and by means of set-screws *i'* and pins *s'*, which are fastened in the head, and which play in the slots in the ears. By these means I can exactly adjust the position of the ink-rollers so that they will accurately apply the ink to the dies, type, or stamp.

In Fig. 7 I show the work-gages, which are attached to the platen, as seen in Fig. 3. *a''* are pins, through the heads whereof rods *b''* pass, which are fastened, as desired, by side screws *c''*. *d''* are knobs on the ends of the rods *b''*, which come directly in contact with the work. The shank part of the pins *a''* en-

ter hole *e''*, made in the platen. *f''* are set-screws, which pass through the side of the platen and hold the shanks of the pins in such position as desired. This form is much superior to the old form of gages for various reasons, among them the fact that there is no clamping-screw passing down through the gages, which have a tendency to give them an upward curve, so that ultimately they become unfit for use.

I have described those parts of the machine only which are intimately connected with my improvements.

It will be obvious to those who are skilled in this art that many modifications may be made in the details of construction and still the essentials of my improvements be employed.

Having described my invention, I claim—

1. The combination, in a press, of toggles which actuate the platen, and a wedge arranged in line with the fulcrums of the toggles and adjustable on said line, substantially as set forth.
2. The combination, in an inking device for presses, of rollers supported upon a moving

carriage, and adjustable rails, one at each end of the inking-rollers, which determine the position of the rollers irrespective of the carriage and adjust their position relative to the type or die, substantially as set forth.

3. The combination, in an inking apparatus, of a carriage for the rollers, provided with cylindrical recesses and slotted sides, and vertically-moving cylindrical slotted blocks constructed and arranged to receive and hold the shafts of the rollers and which conform to the recesses in the carriage, substantially as set forth.

4. The combination, in a press, of inking-rollers supported by and moving with a carriage and means whereby the extent of forward movement of the carriage from a fixed initial point may be adjusted, substantially as set forth.

Signed at New York, in the county of New York and State of New York, this 15th day of May, A. D. 1890.

CHARLES A. LIEB.

Witnesses:

PHILLIPS ABBOTT,  
FREDERICK SMITH.