

J. A. SMITH.

Improvement in Reed Organ-Stop Action.

No. 132,419.

Patented Oct. 22, 1872.

Fig. 1.

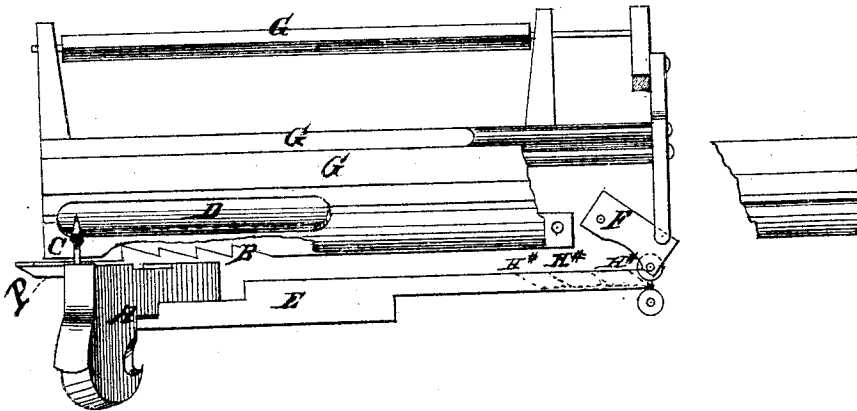
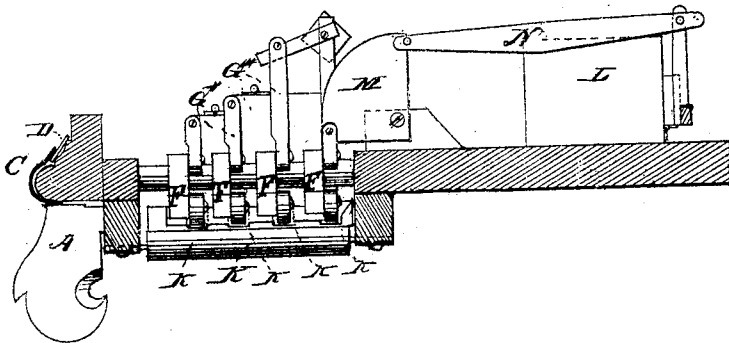

Fig. 3.



Witnesses.

Geo W. Haywood
C C Conner

Inventor.

John A. Smith

UNITED STATES PATENT OFFICE.

JOHN A. SMITH, OF ERIE, PENNSYLVANIA, ASSIGNOR TO BURDETT ORGAN COMPANY, OF SAME PLACE.

IMPROVEMENT IN REED-ORGAN STOP ACTIONS.

Specification forming part of Letters Patent No. **132,419**, dated October 22, 1872.

To all whom it may concern:

Be it known that I, JOHN A. SMITH, of the city and county of Erie, and State of Pennsylvania, have invented a certain Improvement in Reed-Organs, of which the following is a specification, reference being had to the accompanying drawing.

This invention consists in opening the stops of a reed-organ, in any desired succession, by means of an improved knee or foot lever instead of a manual register, thereby relieving the performer from the necessity of removing his hands from the keys to do so.

Figure 1.—A represents the knee-lever; B the ratchet-work by which the knee-lever's use is graduated. C is the indicator. D is the tablet containing the names of the stops. E is the moving table. F is one of a series of flexible elbows acted upon by the moving table E. G indicates the stops. P is the knee-lever latch to engage with the ratchet B.

Fig. 2.—E is the moving table. H indicates a succession of recesses in the moving table E, with inclines H*, Fig. 1, which act upon the flexible elbows when the knee-lever is pressed forward, these recesses being so constructed as to operate the stops in any order of succession that may be desired. I is a fulcrum attached to the moving table E.

Fig. 3.—K indicates friction-rollers. L is the sub-bass box. M is the elbow, and N is the lever which opens the sub-bass. G* indicates the ends of the stops with their elbow connections. H* indicates the inclines in the moving table E. (See Fig. 1.)

It will therefore be seen that by moving the knee-lever A to the right it engages with the ratchet-lever B at the same time that the indicator C, attached to the said knee-lever, moves past the face of the tablet D, pointing to the names of the stops thereon. The lever A is disengaged by raising the latch P by the knee at any time in the usual manner. The recesses in the moving table may vary in number, more or less, and be arranged in any desired order of succession.

I claim—

1. The moving table E, with the recesses H and inclines H*, substantially as described.
2. In combination with the above, the lever A, and indicator C with the tablet D, substantially as set forth.

JOHN A. SMITH.

Witnesses:

GEO. W. HAYWOOD,
C. C. CONVERSE.