

T. M. Millett, Sr.,

Mill Gearing.

No. 110,151.

Patented Dec. 13. 1870.

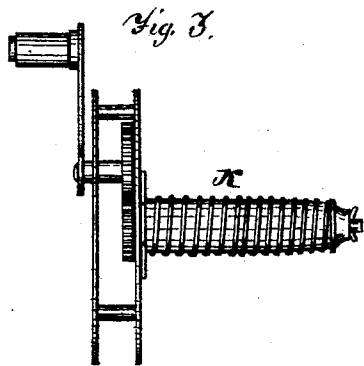
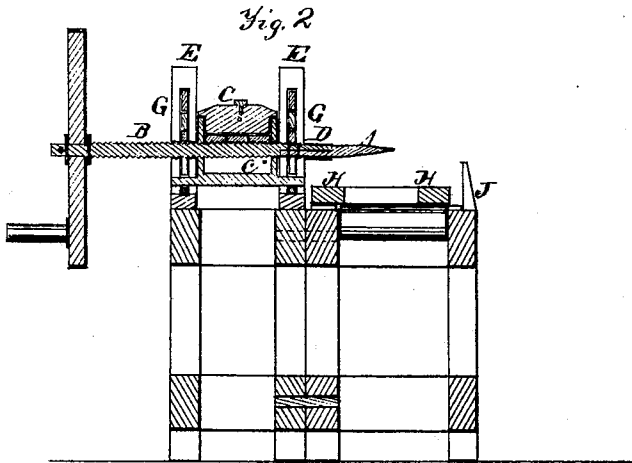
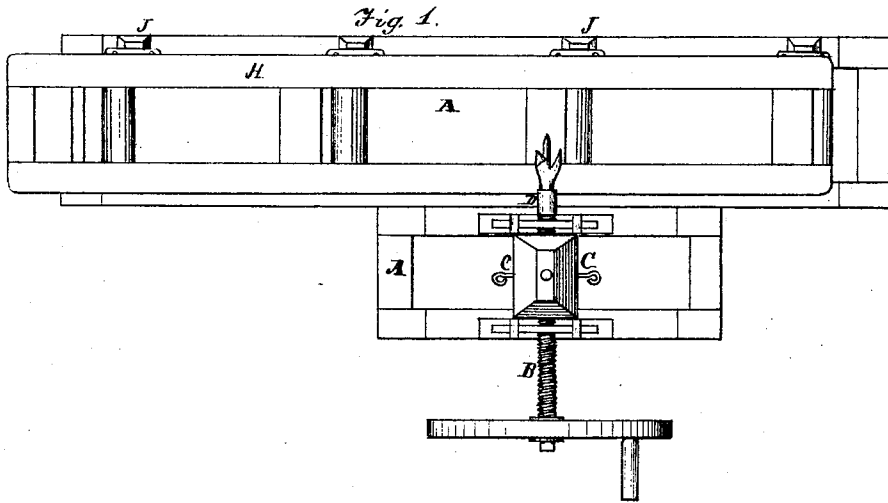

Attest; }
 } *Thos. J. Blair*
 } *Isaac Inman*

Inventor,

Thos. Millett, Sr.

UNITED STATES PATENT OFFICE.

THOMAS M. MILLETT, SR., OF SAVANNAH, GEORGIA.

IMPROVEMENT IN GEARINGS FOR MACHINERY.

Specification forming part of Letters Patent No. **110,151**, dated December 13, 1870.

To all to whom it may concern:

Be it known that I, THOMAS M. MILLETT, Sr., of Savannah, in the county of Chatham and State of Georgia, have invented a new and useful Improvement in Gearing, adapted to a variety of machines; and I do hereby declare that the following is a full, clear, and exact description thereof, which will enable others skilled in the art to make and use the same, reference being had to the accompanying drawing, forming a part of the specification.

The present invention relates to the combination and arrangement of parts in gearing capable of being adapted to a variety of machines.

I have shown and described the gearing as adapted to a boring-machine, especially intended and designed for the boring of fence-posts, in the manufacture of rail fences, to form the mortises for receiving the ends of the rails constituting the fence; also, the boring of timber for building purposes; and, further, for the boring of logs for pumps; and it consists in so arranging a carriage moving on rollers upon a main frame for the reception of the posts to be bored, so constructed as to move across the plane of operation of the boring-tool, whereby the post or timber can be fed to the boring-tool, and thus presented to it at the proper point for being mortised or bored.

To this main frame is joined a side frame, upon which is mounted an endless screw, working in a nut-casting inclosed within a suitable box or case, one end of said screw being provided with any of the known devices for retaining the bit in firm position, while at or near the other end is securely attached a fly-wheel of any desired diameter; or, if desired, two or three of such wheels may be used, and of any diameter.

The screw rests upon suitable journals, and is capable of being adjusted at higher or lower angle by means of wedges, which are located on opposite sides of the box inclosing the nut-casting, through which the wormed or screw-thread shaft extends, by the use of which the bit is always pressing against the post to be bored, thus dispensing with the force of the hand to cause said bit to bite the wood.

In the accompanying drawing, which forms a part of this specification, Figure 1 represents a top or plan view of the gearing as ap-

plied to a boring-machine; Fig. 2, a transverse central section; Fig. 3, a side view of my improved multiplying-gear and its attachments.

A A A is the frame of the boring-machine in Figs. 1 and 2, which frame should be substantially constructed, to prevent the vibration of the operating parts. B is the endless screw passing through the nut-casting, at the end of which there is a socket (marked D) for placing any bit required for boring; C C, the nut-casting, which draws the endless screw B through it, inclosed in a box or case on front of frame A, resting on suitable journals, as is represented in Fig. 2, (marked E E.)

The nut-casting, inclosed in case C C, is capable of being adjusted at a higher or lower angle by means of wedges G G in Fig. 2.

H H in Fig. 1 is a carriage, moving on rollers upon the main frame A, for the reception of timber to be bored, with brackets on the back of frame A, to hold more securely the timber on said carriage while boring, which shows in Fig. 2, (marked J.)

The multiplying speed of wheel, Fig. 3, to be attached to endless screw, with its coiled spring, is to facilitate the drawing out of endless screw and bit after boring by the end of said spring to press against the frame at the entrance of the endless screw, causing a pressure for the endless screw to come out after boring. It is particularly adapted where the boring of logs for pumps is required, and increases the force of drawing out after boring.

The stand on which the log is placed for boring is arranged by placing the carriage A A lengthwise, instead of crosswise, so as to receive the bit of endless screw with the center of log to be bored.

What I claim is—

1. The wheel F, carrying the endless screw A, working in nut-castings within a regulating-box, as shown and described, said screw being adjustable by means of wedges or gib and key, all combined and arranged as herein shown and described.

2. In combination with the foregoing, the multiplying gear-wheel K, with its coiled spring, as shown and described.

THOMAS M. MILLETT, SR.

Witnesses:

AUGUSTUS BARIÉ,
H. S. DRUSE.