

(19) World Intellectual Property Organization  
International Bureau



(43) International Publication Date  
6 March 2003 (06.03.2003)

PCT

(10) International Publication Number  
WO 03/018088 A1

(51) International Patent Classification<sup>7</sup>: A61M 1/16

(21) International Application Number: PCT/US02/26519

(22) International Filing Date: 20 August 2002 (20.08.2002)

(25) Filing Language: English

(26) Publication Language: English

(30) Priority Data:  
09/938,007 23 August 2001 (23.08.2001) US

(71) Applicant: MICHIGAN CRITICAL CARE CONSULTANTS, INC. [US/US]; Suite 3, 3550 West Liberty, Ann Arbor, MI 48103 (US).

(72) Inventors: CHAMBERS, Sean, D.; 2976 Green Valley Drive, Ann Arbor, MI 48103 (US). MONTOYA, Jean, P.; 1610 Harbal Drive, Ann Arbor, MI 48105 (US).

(74) Agents: SOSENKO, Eric, J. et al.; Brinks Hofer Gilson & Lione, P.O. Box 10087, Chicago, IL 60610 (US).

(81) Designated States (*national*): AE, AG, AL, AM, AT, AU, AZ, BA, BB, BG, BR, BY, BZ, CA, CH, CN, CO, CR, CU, CZ, DE, DK, DM, DZ, EE, ES, FI, GB, GD, GE, GH, GM, HR, HU, ID, IL, IN, IS, JP, KE, KG, KP, KR, KZ, LC, LK, LR, LS, LT, LU, LV, MA, MD, MG, MK, MN, MW, MX, MZ, NO, NZ, PL, PT, RO, RU, SD, SE, SG, SI, SK, SL, TJ, TM, TR, TT, TZ, UA, UG, UZ, VC, YU, ZA, ZW.

(84) Designated States (*regional*): ARIPO patent (GH, GM, KE, LS, MW, MZ, SD, SL, SZ, TZ, UG, ZM, ZW), Eurasian patent (AM, AZ, BY, KG, KZ, MD, RU, TJ, TM), European patent (AT, BE, BG, CH, CY, CZ, DE, DK, EE, ES, FI, FR, GB, GR, IE, IT, LU, MC, NL, PT, SE, SK, TR), OAPI patent (BF, BJ, CF, CG, CI, CM, GA, GN, GQ, GW, ML, MR, NE, SN, TD, TG).

Published:  
— with international search report

For two-letter codes and other abbreviations, refer to the "Guidance Notes on Codes and Abbreviations" appearing at the beginning of each regular issue of the PCT Gazette.

(54) Title: APPARATUS FOR EXCHANGING GASES IN A LIQUID

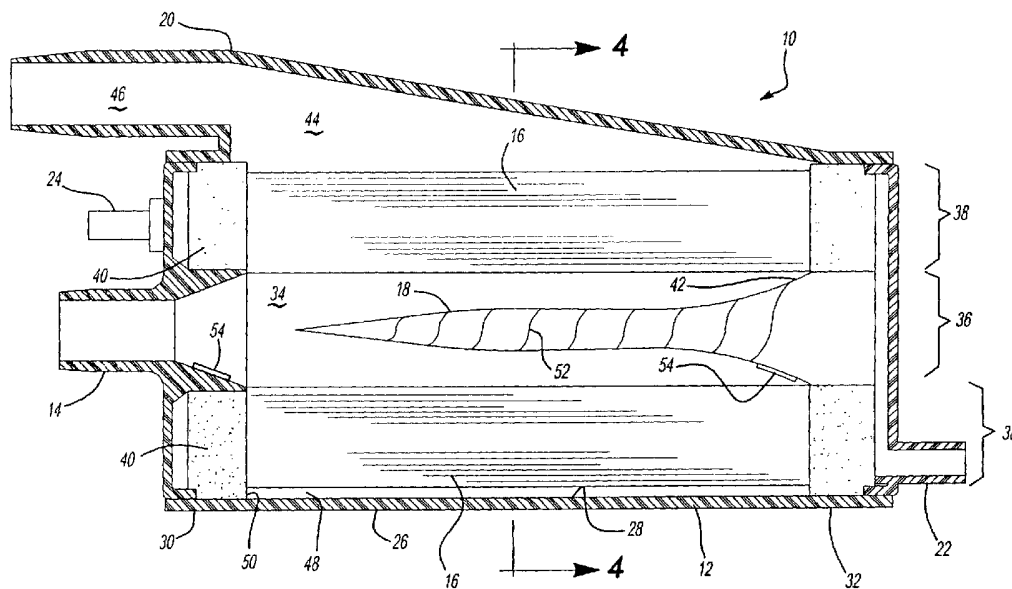

(57) Abstract: An apparatus for exchanging gases in a liquid is provided. The apparatus comprises a housing (12), a first inlet (14), a gas exchange medium (16), a separator (18), a first outlet (20), and a second inlet and outlet (29, 24). The apparatus may further comprise a circumferential collection gap (48) that collects liquid from the gas exchange medium (16) and directs it toward the first outlet (20). Also, the apparatus may further comprise a compliant chamber (160) positioned near the first inlet. The compliant chamber reduces the overall impedance of the apparatus. The apparatus is particularly well-suited for use as an implantable, artificial lung. In this embodiment, the liquid comprises blood and the apparatus exchanges supplied oxygen for waste carbon dioxide.



WO 03/018088 A1

## APPARATUS FOR EXCHANGING GASES IN A LIQUID

### FIELD OF THE INVENTION

**[0001]** The present invention relates to an apparatus that allows for the exchange of gases in a liquid sample. More specifically, the invention relates to a blood oxygenator, which allows external oxygen to be incorporated into a blood sample while carbon dioxide is removed from the sample.

**[0002]** The invention includes several features that make it particularly well suited for use as an artificial lung. Indeed, the apparatus according to the present invention has several characteristics that make it suitable for use in an extracorporeal bypass circuit, as well as a temporary in vivo replacement for a mammalian lung.

### BACKGROUND OF THE INVENTION

**[0003]** Blood oxygenators are frequently used to accomplish the gas exchange functions normally performed by the lungs. Conventional blood oxygenators contain a gas exchange medium positioned adjacent a flowing stream of blood. When attached to an oxygen supply, the blood is perfused with oxygen and carbon dioxide is removed.

**[0004]** Typically, these devices are utilized when a patient's lungs are temporarily disabled. The situations in which a patient needs a blood oxygenator can generally be classified into two types: short term and indefinite term. Open heart surgery provides an example of a short-term need for a blood oxygenator. During this procedure, a patient's heart can be stopped temporarily. To continue vital functions of the circulatory system, an extracorporeal bypass circuit is constructed, in which a pump sends the patient's blood through a series of devices. A blood oxygenator is frequently included in these circuits so that the patient's blood can continue to deliver oxygen to the tissues of the body.

**[0005]** The prior art provides several examples of blood oxygenators that are suitable for use in these extracorporeal bypass circuits. Unfortunately, the use of these external circuits are not ideal for situations in which the need for an artificial blood oxygenator spans an indefinite term. The extracorporeal bypass circuits are

bulky, labor intensive, and expensive to operate. For these reasons and more, these circuits are typically only used to manage the blood oxygenation needs of the indefinite term patient who requires long term intensive care.

**[0006]** Many indefinite term patients are those awaiting a lung transplantation procedure, which has become a well-established clinical procedure for several respiratory maladies, including chronic obstructive pulmonary disease, emphysema, cystic fibrosis, and idiopathic pulmonary fibrosis. Unfortunately, many patients who would benefit from a lung transplant must wait to receive a suitable lung. Furthermore, immunosuppressive therapy, which is commonly used prior to transplantation procedures, is generally a contraindication to extracorporeal support, such as by a bypass circuit, due to the risk of bacterial infections.

**[0007]** As a consequence, there is a need for a blood oxygenator that is suitable for use in indefinite term patients. A blood oxygenator that is able to provide gas exchange functions without imposing a significant load onto the heart would be particularly desirable. Furthermore, an implantable blood oxygenator, which could effectively serve as an artificial lung, would enhance the lifestyle of indefinite term patients and provide a bridge therapy to lung transplantation.

#### SUMMARY OF THE INVENTION

**[0008]** The present invention provides an apparatus that allows for exchange of gases in a liquid sample. In a particularly preferred embodiment, the invention provides a blood oxygenator. The blood oxygenator according to the present invention has several characteristics that make it suitable for use as an artificial lung in indefinite term patients.

**[0009]** In one embodiment, the apparatus according to the present invention comprises a housing having an inner surface, a first end and a second end. The housing defines an interior chamber that has inner and outer portions. A gas exchange medium is disposed in the outer portion of the interior chamber, and a separator is disposed in the inner portion. The separator preferably extends substantially along the length of the gas exchange medium.

**[0010]** The apparatus includes first and second inlets and first and second outlets.

**[0011]** The first inlet is adapted to introduce a stream of liquid into the interior chamber, on an axial path extending from the first end of the housing to the second end, and preferably directed toward the separator.

**[0012]** The first outlet allows the liquid to exit the apparatus after flowing through or past the gas exchange medium. In the application described in detail herein, the first inlet and outlet serve as a blood inlet and outlet.

**[0013]** The second inlet and second outlet are adapted to introduce and carry away, respectively, gas from the gas exchange medium. In the application described herein, the second inlet and outlet serve as an air or oxygen inlet and outlet.

**[0014]** The separator functions to radially divert the stream of liquid off its axial path and toward the gas exchange medium. Consequently, the liquid flows principally radially through the gas exchange medium.

**[0015]** The outer portion of the housing's chamber may further define a circumferential collection gap that collects liquid exiting from the gas exchange medium and directs it toward the first outlet.

**[0016]** Preferably, the housing and first outlet both have a generally elliptical cross-sectional shape. Particularly preferable, the ovoid shapes of these elements are oriented such that a major axis of the elliptical shape of one element is substantially perpendicular to a major axis of the elliptical shape of the other element.

**[0017]** The apparatus of the present invention may also include a compliant chamber placed on a communicative passageway that carries liquid to the first inlet. In a preferred embodiment, the compliant chamber comprises a relatively non-elastic chamber formed by the communicative passageway. One end of the chamber can be fixedly attached to a surface while another end remains adjustable. Alternatively, the compliant chamber can be formed of an elastic material. Also alternatively, the compliant chamber can be placed in a sealed container having a fluid that surrounds the chamber. Furthermore, one or more springs could be utilized to store energy and provide the desired compliance.

**[0018]** The apparatus may further comprise a means for warming and/or cooling the liquid being passed through the device. In one embodiment, a

conductive element, such as electrical tape, is disposed on the separator. The electrical tape is responsive to an external temperature regulator and warms the liquid, such as blood, when an electrical current passes through the tape.

**[0019]** The present invention provides an apparatus with impedance characteristics that allow it to be incorporated into the circulation without placing a significant load on the right heart. Indeed, the impedance characteristics of the blood oxygenator according to the present invention allows for perfusion of the oxygenator by the native circulation without detrimental effects on the right ventricle.

#### BRIEF DESCRIPTION OF THE DRAWINGS

**[0020]** Figure 1 is a perspective view of a blood oxygenator according to a first preferred embodiment of the present invention.

**[0021]** Figure 2 is an end view, partially broken away, of the blood oxygenator illustrated in Figure 1.

**[0022]** Figure 3 is a cross-sectional view of the blood oxygenator taken along line 3,3 in Figure 2.

**[0023]** Figure 4 is a cross-sectional view of the blood oxygenator taken along line 4,4 in Figure 3.

**[0024]** Figure 5 is a partial cross-sectional view of a blood oxygenator according to a second preferred embodiment of the present invention and illustrates the use of a compliant chamber in the oxygenator.

**[0025]** Figure 6 is a cross-sectional view, partially broken away, of a second preferred embodiment of a compliant chamber in the blood oxygenator.

**[0026]** Figure 7 is a cross-sectional view, partially broken away, of a third preferred embodiment of a compliant chamber in the blood oxygenator.

**[0027]** Figure 8 is a cross-sectional view, partially broken away, of a fourth preferred embodiment of a compliant chamber in the blood oxygenator.

#### DETAILED DESCRIPTION OF THE INVENTION

**[0028]** The following description of preferred and alternate embodiments of the invention provides examples of the present invention. The embodiments discussed herein are merely exemplary in nature, and are not intended to limit the

scope of the invention in any manner. Rather, the description of these preferred embodiments serves to enable a person of ordinary skill in the relevant art to make and use the present invention.

**[0029]** The present invention provides an apparatus for exchanging gases in a liquid. The apparatus is particularly well suited for use as a blood oxygenator. Figures 1 through 4 illustrate a blood oxygenator 10 in accordance with a first preferred embodiment of the present invention.

**[0030]** The blood oxygenator 10 comprises a housing 12, a first inlet 14, a gas exchange medium 16, a separator 18, a first outlet 20, a second inlet 22, and a second outlet 24.

**[0031]** The housing 12 comprises the main body of the oxygenator 10, and has an exterior surface 26, an inner surface 28, a first end 30, a second end 32, and a wall extending therebetween. The housing 12 defines an interior chamber 34 that provides the space in which gas exchange functions are performed.

**[0032]** As best illustrated in Figure 2, the housing 12 preferably has an elliptical cross-sectional shape. The elliptical shape confers several benefits onto the oxygenator 10, including increased ease of handling and suitability for implanting into the thoracic cavity of a mammal, such as a human.

**[0033]** The housing 12 is preferably comprised of a rigid material, such as a plastic. The use of biocompatible materials known to those skilled in the art facilitates the use of the oxygenator 10 as an implanted artificial lung. A particularly preferred material for the housing 12 is polycarbonate.

**[0034]** The housing 12 defines the outermost surface of the oxygenator 10, and therefore dictates the size of the oxygenator 10. Preferably, the housing 12 is dimensioned such that the ratio of its major axis to its minor axis is between about 1 and 4. Particularly preferably, the ratio of major axis to minor axis is about 1.32. The inventors have found that a blood oxygenator according to the present invention that has a length of about 6.375" and a maximum height of about 4.219" facilitates implantation of the oxygenator.

**[0035]** As indicated above, the interior chamber 34 provides the necessary space for gas exchange to occur. As best illustrated in Figure 2, the interior chamber 34 can be divided into two primary regions: an inner portion 36 and an

outer portion 38. The inner portion 36 comprises the center of the chamber 34, while the outer portion 38 comprises the periphery of the chamber 34, i.e. the area of the chamber 34 that is adjacent the inner surface 28 of the housing 12. Since the inner 36 and outer 38 portions are regions of the interior chamber 34, there is no precise line that defines the regions.

**[0036]** As best illustrated in Figure 3, the first inlet 14 comprises a communicative passageway that provides communication to the interior chamber 34 of the oxygenator 10. Preferably the first inlet 14 comprises a passageway that traverses the first end 30 of the housing 12 at a point that allows the first inlet 14 to provide direct access to the inner portion 36 of the interior chamber 34.

**[0037]** The first inlet 14 is preferably integrally formed by the housing 12. Alternatively, any suitable communicative passageway can be utilized. Furthermore, the first inlet 14 may define features that facilitate connection to another communicative passageway, such as a section of a plastic tubing or the like. Such features can include barbs, hooks, clamps, and any other suitable connection feature. Alternatively, the first inlet 14 can be adapted such that it can be directly attached, such as by sewing or other suitable means, to tubes or a vessel of the native circulatory system.

**[0038]** The gas exchange medium 16 provides the surface area necessary for the exchange of gases in the liquid to occur. Preferably, as best illustrated in Figure 4, the gas exchange medium 16 is disposed in the outer portion 38 of the interior chamber 34, leaving the inner portion 36 free of the gas exchange medium 16. Also preferable, the gas exchange medium 16 is disposed completely around the inner portion 36 of the chamber 34.

**[0039]** The gas exchange medium 16 is adapted to carry a first gas, such as oxygen, in such a manner that allows the gas to be taken up by a liquid contacting the medium 16, such as blood. Further, the medium 16 is adapted to carry away any excess of the first gas, as well as any other gas given off by the liquid, such as carbon dioxide. Many examples of suitable gas exchange mediums are known in the art, and any can be employed in the present invention. The medium preferably comprises a plurality of individual hollow fibers, such as those discussed in United States Patent No. 5,964,725 to Sato, et al. for a GAS EXCHANGE APPARATUS

USING IMPROVED SILICONE RUBBER HOLLOW FIBER and 6,004,511 to Biscegli for a HOLLOW FIBER OXYGENATOR. Alternatively, the gas exchange medium 16 can comprise any suitable exchange medium known to those skilled in the art. A particularly preferred gas exchange medium comprises a two-dimensional mesh in which fibers along one dimension are hollow gas exchange fibers and fibers in the second dimension are connecting support fibers.

**[0040]** Preferably, as best illustrated in Figure 3, the gas exchange medium 16 is seated within the housing 12. The seating of the medium 16 prevents movement of the medium 16 that may interfere with operation of the oxygenator 10, such as movement of the medium 16 toward or into the inner portion 36 of the interior chamber. Preferably, a section of potting material 40 is disposed at both the first 30 and second 32 ends of the oxygenator 10 and around the respective ends of the gas exchange medium 16. The potting material 40 is preferably positioned to separate the gas phase from the liquid phase within the oxygenator 10. Various potting materials are used in conventional blood oxygenators, and a variety of types will be known to those skilled in the art. United States Patent No. 6,113,782 to Leonard for POTTING OF TUBULAR BUNDLES IN HOUSING provides an example of suitable potting material.

**[0041]** During operation, blood enters the oxygenator 10 through the first inlet 14 along an axial path extending from the first end 30 toward the second end 32. Because the gas exchange medium 16 is disposed around the inner portion 36 of the interior chamber 34, the liquid must be radially diverted so that it can encounter the medium 16. Accordingly, a separator 18 is employed. The separator 18 functions to radially divert the incoming stream of liquid off of its initial axial path and toward the gas exchange medium 16. Further, the separator 18 can function to prevent impingement of the liquid on the second end 32 of the oxygenator, or the potting material 40 disposed therein.

**[0042]** As illustrated in Figure 3, the separator 18 is disposed in the inner portion 36 of the interior chamber 34 along the lengthwise axis of the housing 12. Preferably, the separator 18 comprises an element separate from the housing 12, and one end of the separator 18 is fixedly secured to the second end 32 of the housing 12, i.e., the end opposite the first inlet 14. This attachment can be direct to

the housing 12, or alternatively, to the potting material 40, which is secured to the housing 12. Alternatively, the separator 18 can be integrally formed with the interior surface of the housing. Also preferable, the separator 18 extends substantially along the length of the gas exchange medium 16. Preferred lengths for the separator 18, as compared to the length of the gas exchange medium 16, are within the range of about 50% to about 99%. Particularly preferable, the separator 18 is between about 75% and 95% of the length of the medium 16. Most preferable, the separator 18 is approximately 90% as long as the gas exchange medium 16.

**[0043]** The separator 18 is preferably conical in shape. As illustrated in Figure 3, the separator 18 is preferably positioned such that the tip of the conical form is substantially opposite the first inlet 14. Also preferable, the cross-sectional shape of the separator 18, at any position along its length, is generally elliptical. Furthermore, the separator 18 may define a tapered surface 42 at a point near the end secured to the housing 10. This tapered surface 42 prevents the incoming stream from impinging on the potting material 40 or inner surface 28 of the housing 10 at the second end 32, i.e., the end opposite the first inlet 14. This also lowers the pressure drop that occurs across the gas exchange medium 16. As illustrated in Figure 3, the opposite end of the separator 18, i.e., the end near the first inlet 14, preferably draws to a point.

**[0044]** The overall shape of the separator functions to prevent significant pressure drop across the oxygenator 10. For example, the point near the first inlet 14 allows the separator 18 to radially divert incoming fluid while providing minimal resistance to flow. Also, the tapered surface 42 at the opposite end allows the separator 18 to effectively divert a flowing stream of liquid having less volume toward the gas exchange medium 16.

**[0045]** Being positioned within the housing 10, the separator 18 comes into contact with liquid flowing through the oxygenator 10 during operation. As indicated above, the liquid will frequently comprise blood, which contains numerous living cells. Accordingly, the separator 18 is preferably formed of a biocompatible material, such as biocompatible plastic. Particularly preferable, the separator 18 is fabricated from the same material as the housing 12.

**[0046]** The first outlet 20 comprises a communicative passageway that provides fluid communication between the interior chamber 34 of the oxygenator 10 and the external environment. For example, the first outlet 20 can be connected to the remainder of an extracorporeal bypass circuit, or to the pulmonary artery of a patient. In the flow path, the first outlet 20 is positioned after the gas exchange medium 16. Accordingly, the first outlet 20 functions to carry away liquid that has encountered the medium 16, i.e., liquid that has undergone gas exchange.

**[0047]** As best illustrated in Figure 3, the first outlet 20 preferably comprises a collection portion 44 and an outlet portion 46. The collection portion 44 provides the opening that collects liquid from the gas exchange medium 16, and the outlet portion 46 provides the passageway that allows the liquid to exit the oxygenator 10. Preferably, the collection portion 44 comprises a tapered region having an opening that extends substantially along the length of the gas exchange medium 16. This allows for even collection of liquid from the medium 16 and helps to prevent pressure drop. The taper preferably proceeds from a narrow end located near the second end 32 of the housing 12, to an enlarged end located near the first end 30. Preferably, the taper proceeds at an angle of between approximately 5° and 20° from parallel to the lengthwise axis of the oxygenator 10. Particularly preferable, the taper proceeds at an angle of approximately 9.7° degrees from parallel to the lengthwise axis of the oxygenator 10. The enlarged end provides the transition, i.e., direct fluid communication, from the collection portion 44 to the outlet portion 46.

**[0048]** As best illustrated in Figure 2, the collection portion 44 preferably has an elliptical cross-section shape. Particularly preferable, a major axis of the elliptical cross-sectional shape of the collection portion 44 is substantially perpendicular to a major axis of the elliptical cross-section shape of the housing 12.

**[0049]** As best illustrated in Figure 1, the collection portion 44 preferably tapers such that the outlet portion 46 has a circular cross-sectional shape. The circular cross-sectional shape facilitates connection of the first outlet 20 to a communicative passageway that carries away exiting liquid, such as a vascular graft or a section of tubing.

**[0050]** Preferably, the first outlet 20 is integrally formed by the housing 12. Also preferable, the outlet portion 46 is substantially parallel to the first inlet 14. The

first outlet 20, in a manner similar to that described above for the first inlet 14, is preferably adapted to facilitate connection to tubes or other passageways, or even to facilitate direct attachment, such as by sewing, to a vessel of the native circulatory system.

**[0051]** The oxygenator 10 may further include a third outlet 20a. As illustrated in Figure 1, the third outlet 20a is preferably identical to the first outlet 20. The third outlet 20a is in fluid communication with the interior chamber 34. As shown in the figure, the third outlet 20a preferably has an identical form and configuration as the first outlet 20. Also preferable, the third outlet 20a is preferably positioned opposite the first outlet 20 in the housing 12, such that it is a mirror image of the first outlet 20. In this embodiment, a connector of some type, such as a Y-connector, can be used to join passageways extending from the first 20 and third 20a outlets into a common passageway.

**[0052]** The second inlet 22 and second outlet 24 provide fluid communication with the gas exchange medium. The second inlet 22 defines a communicative passageway that allows an external gas source, such as an oxygen reservoir, to introduce a gas into the medium 16. The second outlet 24 defines a communicative passageway that is able to carry away excess supplied gas and/or a waste gas, such as carbon dioxide, from the medium 16.

**[0053]** Preferably, both the second inlet 22 and second outlet 24 are integrally formed by the housing 12. Also preferable, both the second inlet 22 and second outlet 24 define structural features, as described above for the first inlet 14 that facilitate connection to external communicative passageways, such as tubing and the like.

**[0054]** As best illustrated in Figure 3, a clearance 48 preferably exists between the inner surface 28 of the housing 12 and the gas exchange medium 16. The clearance 48 is preferably formed by leaving a shoulder 50 in the potting material 40, near the inner surface 28 of the housing, that does not seat any portion of the gas exchange medium 16. This creates the clearance 48 between the medium 16 and the inner surface 28. Alternatively, the housing 12 can define a series of shoulders, recesses, and/or other structural features to form the clearance 48.

**[0055]** Preferably, as best illustrated in Figure 4, the clearance 48 forms a circumferential gap that extends around the inner surface 28 of the housing 12. The gap 48 is preferably between about 0.05" and 0.25", and preferably uniform around the inner surface 28 of the housing. Particularly preferable, the gap 48 is about 0.10".

**[0056]** As best illustrated in Figure 3, the clearance 48 preferably merges into the collection portion 44 of the first outlet 20. Thus, the clearance 48 is in fluid communication with the first outlet 20. This allows the clearance 48 to collect liquid that has passed through the gas exchange medium 16 and direct it into the first outlet 20.

**[0057]** The oxygenator 10 may also contain a heater that is adapted to warm blood or another liquid that enters the device. A variety of suitable heaters are known in the art and any can be used. Examples of suitable heaters include heat exchange tubes positioned proximate the gas exchange fibers and a conductive element disposed on a surface of the oxygenator 10. Figure 3 illustrates an example of a conductive element used as a heater. In this embodiment, an electrical tape 52 is disposed on the separator 18, thereby being positioned to contact blood entering the oxygenator 10. The electrical tape 52 warms when a current is passed through it, thereby enabling it to warm the blood. Preferably, the electrical tape 52 is responsive to an external temperature regulator or an internal temperature sensor.

**[0058]** The oxygenator 10 may further include one or more sensors 54. The sensor(s) 54 can comprise any sensor adapted to measure various characteristics of the liquid being passed through the oxygenator 10. For example, when the oxygenator 10 is used to oxygenate blood, the sensor(s) 54 can include sensors adapted to measure O<sub>2</sub> concentration in the blood, CO<sub>2</sub> concentration in the blood, pressure flow, flow rate through the first 14 and/or second 22 inlets, temperature of the blood, pH of the blood, and hemoglobin concentration in the blood. Preferably, the sensor(s) 54 is adapted to provide an output signal to an external device such as a computer and/or printer. Various sensors in accordance with these preferred characteristics are known in the art and will not be described in detail herein.

**[0059]** Figure 5 illustrates a blood oxygenator 110 according to a second preferred embodiment of the invention. This embodiment is similar to the first

preferred embodiment, except as described below. Accordingly, like reference numbers in Figure 5 refer to similar features and/or components illustrated in Figures 1, 2, 3 and 4.

**[0060]** In this embodiment, the oxygenator 110 includes a compliant chamber 160 located near the first inlet 114. The compliant chamber 160 allows the oxygenator 110 to receive the ejection volume of the right ventricle of the heart without placing a significant load on the right ventricle. The compliant chamber 160 allows for a change in volume when pressure is changed, thereby lowering overall impedance of the oxygenator 110. The inventors have discovered that the ability of the compliant chamber 160 to dampen impedance harmonics increases as the chamber is moved closer to the right heart.

**[0061]** The compliant chamber 160 is preferably disposed proximate the first inlet 114. Preferably, as illustrated in Figure 5, the compliant chamber 160 is positioned in line with a communicative passageway 162 that ultimately connects to the first inlet 114. The communicative passageway 162 can be a vascular graft, tubing, or any other suitable passageway. Alternatively, the compliant chamber can be placed within the housing.

**[0062]** Preferably, the compliant chamber 160 defines an enlarged region in the passageway 162. In this embodiment, the chamber 160 can be a bulbous or other shaped region that is integrally formed in the passageway 162. Preferably, the chamber 160 comprises a relatively non-elastic material, such as polyurethane or a silicone-polyurethane copolymer. When secured for use with the oxygenator 110, the chamber 160 is preferably slightly elongated such that it is slightly deformed. The chamber 160 is then able to passively fill with the ejection volume of the right ventricle. (approximately 60-70 cc for human hearts).

**[0063]** Alternatively, the communicative passageway can comprise a flexible tubing, such as a segment of silicone or silicone-urethane copolymer tubing. The passageway forms the compliant chamber when the passageway receives fluid. The flexible nature of the passageway allows the passageway to expand upon receiving liquid, thereby forming the compliant chamber. Upon filling, the compliant chamber elastically recoils and propels the liquid into the first inlet of the oxygenator 110.

**[0064]** As illustrated in Figure 6, one end 164 of the chamber 160 can be fixedly attached to a surface 166, such as a support brace 168. In this embodiment, another end 170 of the chamber 160 is attached to an adjustable surface 172 of the brace 168. This allows the length of the chamber 160 to be adjusted, which allows for the adjustment of the compliance of the chamber 160.

**[0065]** Figure 7 illustrates an alternate brace 174 for use with the chamber 160. In this embodiment, the brace includes two surfaces 176,178 for securing two opposing ends of the chamber 160. Springs 180 are disposed between the surfaces 176,178 such that the surfaces 176,178 are connected to each other. The springs 180 are preferably enclosed or covered to facilitate implantation. Also, the springs 180 are preferably adjustable, and serve to allow for adjustment of compliance of the chamber 160.

**[0066]** As illustrated in Figure 8, the compliant chamber 160 can be positioned within a sealed rigid container 182. In this embodiment, a fluid, such as a gas or liquid, is placed within the sealed container 182 and around the compliant chamber 160. This allows the compliance of the chamber 160 to be regulated by the pressure of the fluid in the container 182.

**[0067]** The present invention also provides a method of operating a blood oxygenator. The method is particularly well suited for operating a blood oxygenator that has a housing defining an interior chamber, a blood inlet in fluid communication with an inner portion of the interior chamber, a gas exchange medium disposed in an outer portion of the interior chamber, a blood outlet in fluid communication with the gas exchange medium and a gas inlet and outlet in fluid communication with the gas exchange medium.

**[0068]** The method preferably comprises introducing blood into the inner portion of the interior chamber by passing the blood through the blood inlet along an axial path that extends substantially from one end of the oxygenator to the opposite end, radially diverting the blood toward the outer portion of the interior chamber such that the blood passes through the gas exchange medium, and directing the blood through the blood outlet such that it exits the oxygenator. The radially diverting the blood is preferably accomplished by utilizing a separator in the interior chamber of the oxygenator, as described above.

**[0069]** In order to facilitate gas exchange, the method preferably further comprises introducing a gas, such as oxygen or air, into the gas inlet such that it passes through the gas exchange medium and exits the oxygenator through the gas outlet.

**[0070]** It will be readily understood that, while the invention has been described herein as being particularly well suited for oxygenating blood, in which the liquid comprises blood and the gas comprises oxygen or air, the invention can also be used in any other application in which it is desired to introduce a gas into a liquid. For example, various anesthetics can be delivered into the device in order to introduce the anesthetic into a patient's blood.

**[0071]** All references cited herein, except to the extent they contradict any statement or definition made herein, are hereby incorporated into this disclosure in their entirety.

**[0072]** The foregoing disclosure includes the best mode devised by the inventors for practicing the invention. It is apparent, however, that several variations in accordance with the present invention may be conceivable to one of ordinary skill in the relevant art. Inasmuch as the foregoing disclosure is intended to enable such person to practice the instant invention, it should not be construed to be limited thereby, but should be construed to include such aforementioned variations, and should be limited only by the spirit and scope of the following claims.

## CLAIMS

We claim:

1. An apparatus for exchanging gases in a liquid, comprising:
  - a housing having a first end, a second end, an inner surface, and defining an interior chamber;
  - a first inlet in fluid communication with the interior chamber and positioned to introduce said liquid into the interior chamber substantially along an axial path extending from the first end toward the second end;
  - a gas exchange medium disposed in the interior chamber;
  - a separator disposed in an inner portion of the interior chamber, the separator extending substantially along the length of the gas exchange medium and adapted to divert a stream of said liquid radially outward toward the gas exchange medium;
  - a first outlet in fluid communication with the interior chamber;
  - a second inlet in fluid communication with the gas exchange medium;and
  - a second outlet in fluid communication with the gas exchange medium.
2. An apparatus in accordance with claim 1, wherein a clearance exists between the gas exchange medium and the inner surface of the housing.
3. An apparatus in accordance with claim 1, wherein the clearance comprises a circumferential collection gap between the inner surface and the gas exchange medium.
4. An apparatus in accordance with claim 3, wherein the circumferential gap extends substantially along the length of the gas exchange medium.
5. An apparatus in accordance with claim 1, wherein the separator defines a generally conical shape.

6. An apparatus in accordance with claim 1, wherein the separator is spaced from the gas exchange medium.

7. An apparatus in accordance with claim 1, wherein an end of the separator is fixedly attached to the housing.

8. An apparatus in accordance with claim 1, wherein the gas exchange medium comprises a plurality of gas exchange fibers.

9. An apparatus in accordance with claim 8, further comprising potting material disposed at the first and second ends of the housing, wherein the gas exchange fibers are seated in the potting material.

10. An apparatus in accordance with claim 1, wherein the first outlet comprises a collection portion and an outlet portion, and wherein the collection portion extends substantially along the length of the gas exchange medium.

11. An apparatus in accordance with claim 10, wherein the collection portion has a narrow end and an enlarged end, and wherein the enlarged end directly communicates with the outlet portion.

12. An apparatus in accordance with claim 10, wherein the collection portion has a generally elliptical cross-sectional shape and the outlet portion has a generally circular cross-sectional shape.

13. An apparatus in accordance with claim 1, wherein the housing has a generally elliptical shape.

14. An apparatus in accordance with claim 13, wherein the first outlet has a generally ovoid shape.

15. An apparatus in accordance with claim 14, wherein a major axis of the elliptical shape of the housing is substantially perpendicular to a major axis of the elliptical shape of the first outlet.

16. An apparatus in accordance with claim 1, further comprising a communicative passageway connected to the first inlet and adapted to carry said liquid to the first inlet, and a compliant chamber disposed on the communicative passageway.

17. An apparatus in accordance with claim 16, wherein the compliant chamber comprises a chamber formed by the communicative passageway and adapted to passively fill with said liquid.

18. An apparatus in accordance with claim 16, wherein one end of the compliant chamber is fixedly attached to a surface.

19. An apparatus in accordance with claim 16, wherein the compliant chamber is comprised of an elastic material.

20. An apparatus in accordance with claim 16, further comprising a rigid container disposed about the compliant chamber.

21. An apparatus in accordance with claim 20, wherein the rigid container is sealed and contains a fluid disposed about the compliant chamber.

22. An apparatus in accordance with claim 1, further comprising a third outlet in fluid communication with the interior chamber.

23. An apparatus in accordance with claim 22, wherein the third outlet is positioned opposite the first outlet.

24. An apparatus in accordance with claim 22, wherein the third outlet is a mirror image of the first outlet.

25. An apparatus in accordance with claim 1, further comprising a sensor adapted to measure a characteristic of said liquid while within said apparatus.

26. An apparatus in accordance with claim 25, wherein the sensor is an oxygen concentration sensor, a carbon dioxide concentration sensor, a pressure flow sensor, a flow rate sensor, a temperature sensor, a pH sensor, or a hemoglobin concentration sensor.

27. An apparatus for exchanging gases in a liquid, comprising:  
a housing having an inner surface, a first end, and a second end, and defining an interior chamber having inner and outer portions;  
a first inlet in fluid communication with the inner portion of the interior chamber;  
a gas exchange medium disposed in the outer portion of the interior chamber;  
a first outlet in fluid communication with the outer portion of the interior chamber;  
a second inlet in fluid communication with the gas exchange medium;  
and  
a second outlet in fluid communication with the gas exchange medium;  
a separator disposed substantially opposite the first inlet and adapted to radially divert said liquid entering the interior chamber toward the gas exchange medium.

28. An apparatus in accordance with claim 27, wherein the separator defines a generally conical shape.

29. An apparatus in accordance with claim 27, further comprising a heater adapted to change the temperature of said liquid.

30. An apparatus in accordance with claim 29, wherein the heater comprises a conductive element disposed on the separator and adapted to warm said liquid when an electrical current is passed through the conductive element.

31. An apparatus for exchanging gases in a liquid comprising:  
a housing having an inner surface, a first end, and a second end, and defining an interior chamber having inner and outer portions;  
a first inlet in fluid communication with the interior chamber and positioned to introduce a stream of said liquid into the interior chamber substantially along an axial path extending from the first end to the second end;  
a gas exchange medium disposed in the outer portion of the interior chamber such that a clearance exists between the gas exchange medium and the inner surface of the housing;  
a conical separator disposed in the inner portion of the interior chamber, the separator extending substantially along the length of the gas exchange medium and adapted to radially divert a stream of said liquid entering the interior chamber through the first inlet toward the gas exchange medium;  
a first outlet in fluid communication with the interior chamber;  
a second inlet in fluid communication with the gas exchange medium;  
and  
a second outlet in fluid communication with the gas exchange medium.

32. An apparatus in accordance with claim 31, wherein the clearance forms a circumferential gap between the inner surface of the housing and the gas exchange medium.

33. An apparatus in accordance with claim 32, wherein the clearance merges with the first outlet.

34. A method of operating a blood oxygenator having a housing defining an interior chamber with an inner portion and an outer portion, and a gas exchange medium disposed in the outer portion of the interior chamber, the method comprising:

introducing a liquid into the inner portion of the interior chamber;

diverting the liquid radially outward toward the outer portion of the interior chamber and passing the liquid radially through the gas exchange medium to oxygenate the liquid;

collecting the liquid after passing through the gas exchange medium;

and

expelling the liquid through an outlet.

35. The method in accordance with claim 34, further comprising introducing a gas such that the gas passes through the gas exchange medium and exits said blood oxygenator through a second outlet.

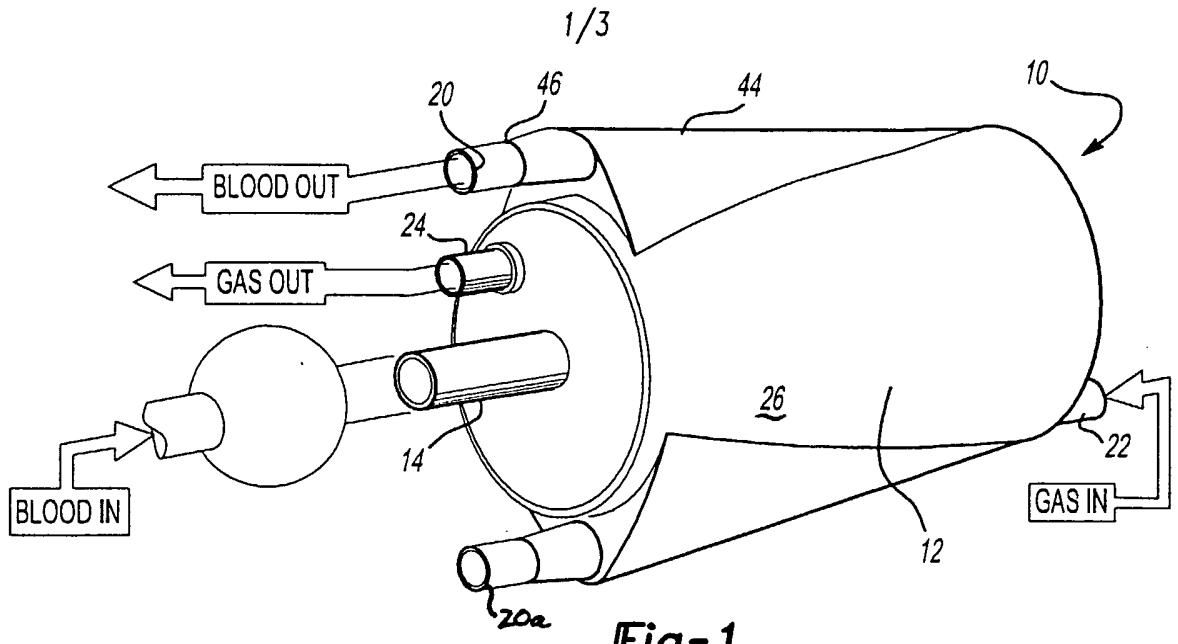

**Fig-1**

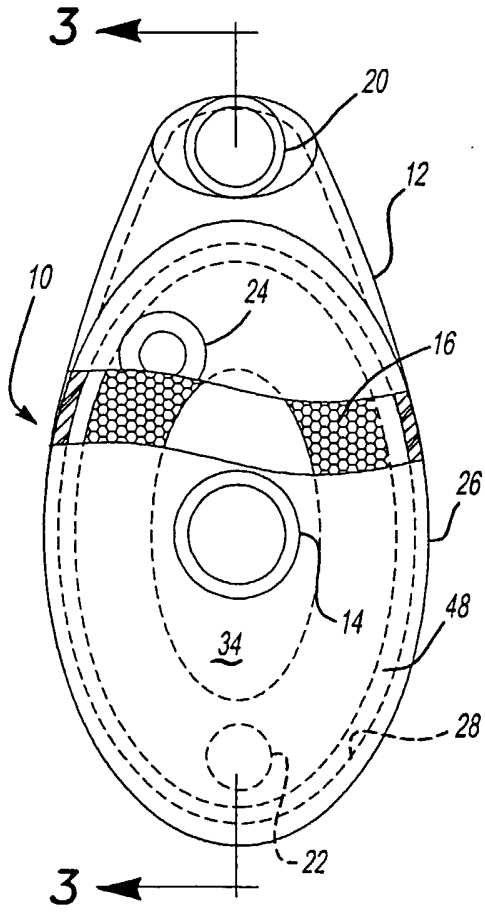

**Fig-2**

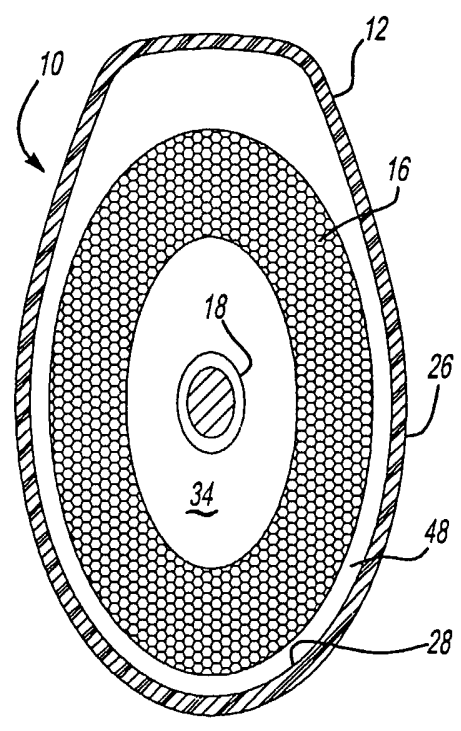

**Fig-4**

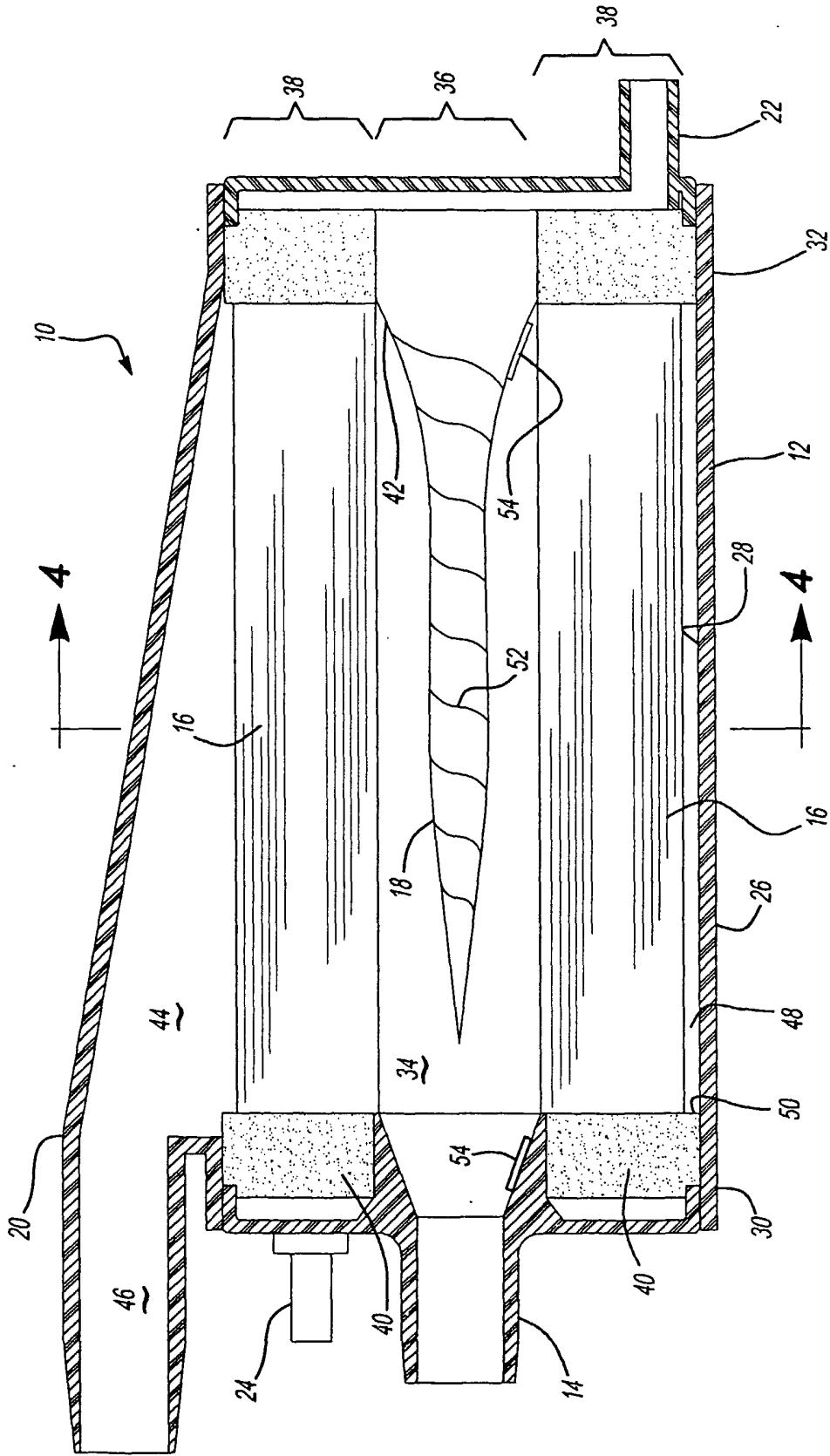

**Fig-3**

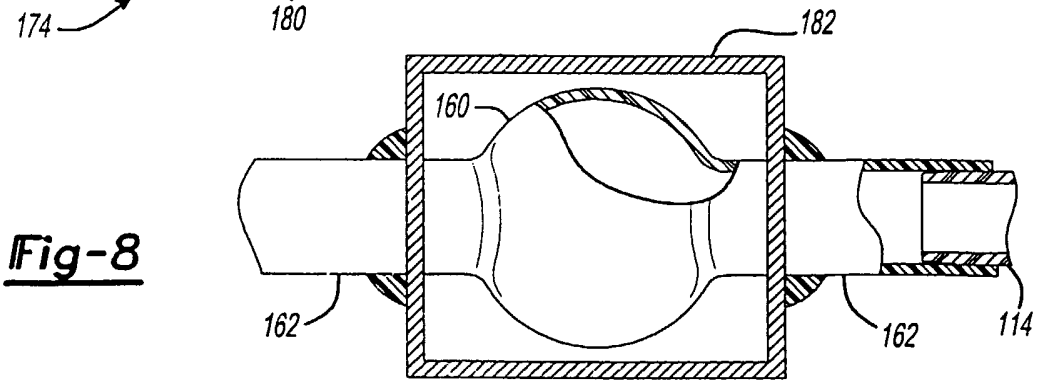
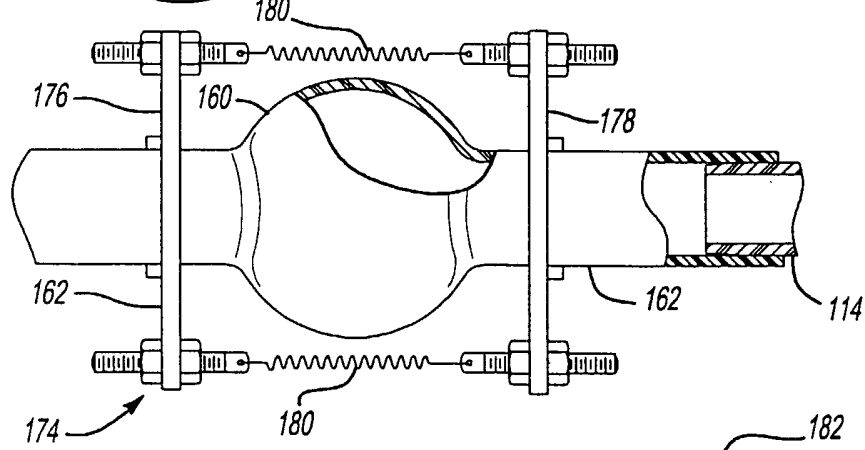
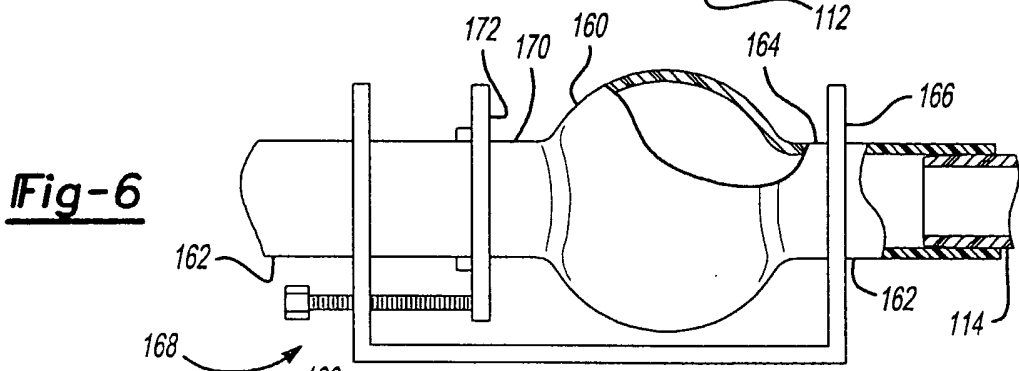
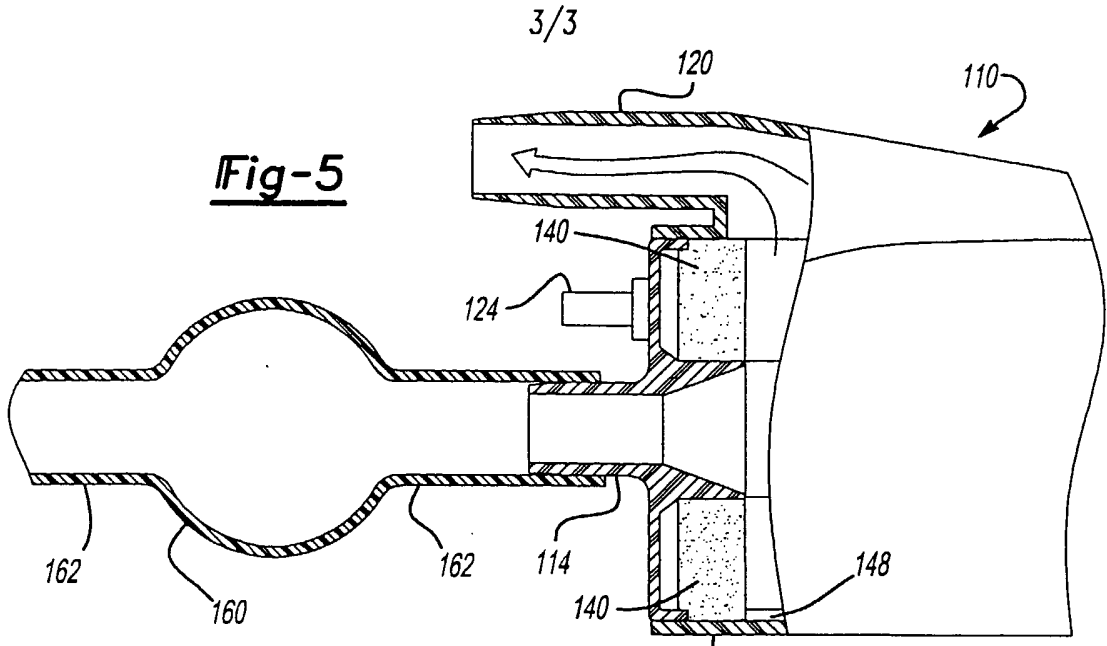

## INTERNATIONAL SEARCH REPORT

Interr Application No

PCT/US 02/26519

A. CLASSIFICATION OF SUBJECT MATTER  
IPC 7 A61M1/16

According to International Patent Classification (IPC) or to both national classification and IPC

## B. FIELDS SEARCHED

Minimum documentation searched (classification system followed by classification symbols)  
IPC 7 A61M

Documentation searched other than minimum documentation to the extent that such documents are included in the fields searched

Electronic data base consulted during the international search (name of data base and, where practical, search terms used)

EPO-Internal

## C. DOCUMENTS CONSIDERED TO BE RELEVANT

Category *	Citation of document, with indication, where appropriate, of the relevant passages	Relevant to claim No.
X	US 4 424 190 A (MATHER III FRANK W ET AL) 3 January 1984 (1984-01-03)  column 6, line 17 - line 26; figures 3,7	1-9, 16, 27-29, 31-35
Y	column 2, line 15 - column 4, line 41	10-15, 17-26, 30
X	US 5 762 869 A (DU MONTELLE JEFFREY P ET AL) 9 June 1998 (1998-06-09)	1-3, 7-9, 22, 23, 27-29, 31-35
Y	column 3, line 10 - line 18; figure 2	13-15
A	column 4, line 57 - column 7, line 43	4-6, 24-26, 30
	--- -/--	

 Further documents are listed in the continuation of box C. Patent family members are listed in annex.

## \* Special categories of cited documents :

- \*A\* document defining the general state of the art which is not considered to be of particular relevance
- \*E\* earlier document but published on or after the international filing date
- \*L\* document which may throw doubts on priority claim(s) or which is cited to establish the publication date of another citation or other special reason (as specified)
- \*O\* document referring to an oral disclosure, use, exhibition or other means
- \*P\* document published prior to the international filing date but later than the priority date claimed

- \*T\* later document published after the international filing date or priority date and not in conflict with the application but cited to understand the principle or theory underlying the invention
- \*X\* document of particular relevance; the claimed invention cannot be considered novel or cannot be considered to involve an inventive step when the document is taken alone
- \*Y\* document of particular relevance; the claimed invention cannot be considered to involve an inventive step when the document is combined with one or more other such documents, such combination being obvious to a person skilled in the art.
- \*Z\* document member of the same patent family

Date of the actual completion of the international search

28 November 2002

Date of mailing of the international search report

09/12/2002

Name and mailing address of the ISA

European Patent Office, P.B. 5818 Patentlaan 2  
NL - 2280 HV Rijswijk  
Tel. (+31-70) 340-2040, Tx. 31 651 epo nl,  
Fax: (+31-70) 340-3016

Authorized officer

Péru, L

## INTERNATIONAL SEARCH REPORT

Intern Application No  
PCT/US 02/26519

C.(Continuation) DOCUMENTS CONSIDERED TO BE RELEVANT		
Category °	Citation of document, with indication, where appropriate, of the relevant passages	Relevant to claim No.
X	WO 96 16684 A (BAXTER INT) 6 June 1996 (1996-06-06)  page 6, line 2 -page 7, line 10 page 10, line 8 - line 10; figure 2 page 12, line 19 -page 13, line 4 ---	1,5-8, 27,28, 31,34,35
X	US 4 082 670 A (JOH YASUSHI) 4 April 1978 (1978-04-04) column 2, line 60 - line 38 column 3, line 13 - line 28 ---	34,35
Y	US 3 907 504 A (HAMMOND GARY W ET AL) 23 September 1975 (1975-09-23) the whole document ---	17-21
Y	WO 99 58171 A (BAXTER INT) 18 November 1999 (1999-11-18)	22-24
Y	page 14, line 20 -page 15, line 18	1-4,8,9, 31-35
A	figure 3 ---	
Y	US 5 698 161 A (MONTROYA JEAN P) 16 December 1997 (1997-12-16)  column 1, line 41 -column 2, line 6 column 7, line 63 -column 8, line 2 figure 6A ---	1-4, 8-12, 31-35
Y	US 5 270 005 A (RAIBLE DONALD A) 14 December 1993 (1993-12-14) column 5, line 44 - line 53 ---	25,26
Y	US 6 047 108 A (SWORD RANDALL JAY ET AL) 4 April 2000 (2000-04-04) column 2, line 47 - line 55 ---	30
A	EP 0 376 298 A (TERUMO CORP) 4 July 1990 (1990-07-04) page 2, line 30 - line 35 page 7, line 17 - line 57 abstract ---	16-21
A	EP 0 089 122 A (CORDIS DOW CORP) 21 September 1983 (1983-09-21) -----	

## INTERNATIONAL SEARCH REPORT

 Interr I Application No  
 PCT/US 02/26519

Patent document cited in search report		Publication date	Patent family member(s)	Publication date
US 4424190	A	03-01-1984	AT 35622 T	15-07-1988
			AU 562663 B2	18-06-1987
			AU 1114283 A	01-09-1983
			BR 8300830 A	16-11-1983
			CA 1191415 A1	06-08-1985
			DD 207657 A5	14-03-1984
			DE 3377332 D1	18-08-1988
			DK 71183 A ,B,	23-08-1983
			EP 0089748 A2	28-09-1983
			JP 1813448 C	18-01-1994
			JP 5009111 B	04-02-1993
			JP 58155863 A	16-09-1983
			MX 159076 A	14-04-1989
			NO 830593 A ,B,	23-08-1983
			NZ 203332 A	28-02-1985
US 5762869	A	09-06-1998	NONE	
WO 9616684	A	06-06-1996	WO 9616684 A1	06-06-1996
US 4082670	A	04-04-1978	JP 978222 C	29-11-1979
			JP 51101790 A	08-09-1976
			JP 54008551 B	17-04-1979
			JP 51093787 A	17-08-1976
			JP 1106474 C	30-07-1982
			JP 51103873 A	14-09-1976
			JP 56040604 B	22-09-1981
			JP 52000095 A	05-01-1977
			JP 56054162 B	24-12-1981
			JP 1169642 C	17-10-1983
			JP 52054296 A	02-05-1977
			JP 58001603 B	12-01-1983
			CA 1069834 A1	15-01-1980
			DE 2603560 A1	05-08-1976
			FR 2299061 A1	27-08-1976
			GB 1512881 A	01-06-1978
			IT 1054589 B	30-11-1981
NL 7600996 A	03-08-1976			
US 3907504	A	23-09-1975	CA 1006709 A1	15-03-1977
			DE 2415528 A1	24-10-1974
			FR 2238918 A1	21-02-1975
			GB 1460116 A	31-12-1976
			IT 1004078 B	10-07-1976
			NL 7402161 A	08-10-1974
WO 9958171	A	18-11-1999	AU 3971399 A	29-11-1999
			BR 9910313 A	23-10-2001
			CN 1308549 T	15-08-2001
			EP 1076572 A2	21-02-2001
			WO 9958171 A2	18-11-1999
			US 2001033813 A1	25-10-2001
US 5698161	A	16-12-1997	EP 0948389 A1	13-10-1999
			JP 2000516852 T	19-12-2000
			WO 9808591 A1	05-03-1998
US 5270005	A	14-12-1993	WO 9204060 A1	19-03-1992

## INTERNATIONAL SEARCH REPORT

Intern | Application No  
PCT/US 02/26519

Patent document cited in search report	Publication date	Patent family member(s)	Publication date	
US 6047108	A	04-04-2000	AU 4739497 A	24-04-1998
			CA 2237179 A1	09-04-1998
			DE 69711023 D1	18-04-2002
			DE 69711023 T2	07-11-2002
			EP 0873147 A2	28-10-1998
			ES 2174226 T3	01-11-2002
			JP 2000501642 T	15-02-2000
			NO 982436 A	28-05-1998
			WO 9814231 A2	09-04-1998
			EP 0376298	A
JP 2811455 B2	15-10-1998			
JP 2180272 A	13-07-1990			
AU 618440 B2	19-12-1991			
AU 4738389 A	05-07-1990			
DE 68909902 D1	18-11-1993			
DE 68909902 T2	17-03-1994			
EP 0376298 A1	04-07-1990			
US 5139741 A	18-08-1992			
AU 648600 B2	28-04-1994			
AU 8691791 A	19-12-1991			
EP 0089122	A	21-09-1983		
			AU 565652 B2	24-09-1987
			AU 1114383 A	25-08-1983
			BR 8300807 A	16-11-1983
			CA 1190443 A1	16-07-1985
			DD 207656 A5	14-03-1984
			DE 3377331 D1	18-08-1988
			DK 71283 A ,B,	20-08-1983
			EP 0089122 A2	21-09-1983
			JP 1814216 C	18-01-1994
			JP 5020111 B	18-03-1993
			JP 58155862 A	16-09-1983
			NO 830578 A ,B,	22-08-1983
			NZ 203283 A	08-11-1985