



(11) **EP 1 995 201 A3**

(12) **EUROPEAN PATENT APPLICATION**

(88) Date of publication A3:
21.03.2012 Bulletin 2012/12

(51) Int Cl.:
B65H 67/048 (2006.01) B65H 65/00 (2006.01)
B65H 54/72 (2006.01)

(43) Date of publication A2:
26.11.2008 Bulletin 2008/48

(21) Application number: **08008137.5**

(22) Date of filing: **28.04.2008**

(84) Designated Contracting States:
AT BE BG CH CY CZ DE DK EE ES FI FR GB GR HR HU IE IS IT LI LT LU LV MC MT NL NO PL PT RO SE SI SK TR
Designated Extension States:
AL BA MK RS

(72) Inventor: **Kitayama, Futoshi**
Fushimi-ku
Kyoto-shi
Kyoto (JP)

(30) Priority: **24.05.2007 JP 2007137340**

(74) Representative: **Liedl, Christine et al**
Hansmann & Vogeser
Patent- und Rechtsanwälte
Albert-Rosshaupter-Strasse 65
81369 München (DE)

(71) Applicant: **TMT Machinery, Inc.**
Osaka-shi, Osaka 541-0041 (JP)

(54) **Yarn take-up winder**

(57) The present invention provides a yarn take-up winder that can more reliably engage yarns on respective empty bobbins. A yarn take-up winder 1 includes rotatable turrets 11, bobbin holders 12, 13 supported by the turrets 11 and on each of which bobbins 20 are set, a turret driving motor that rotationally drives the turrets 11, and a yarn engaging member 25 that is movable between a retract position where the yarn engaging member 25 is retracted from the bobbins 20 and a yarn pressing position where the yarn engaging member 25 presses the yarns Y against the respective bobbins 20. The yarn take-up winder 1 is configured such that the bobbin holder 12, 13 move from a winding position P1 where the yarns Y are wound around the respective bobbins 20 to a yarn engaging position P3 located at yarn path side than the winding position P1 and then the yarn engaging member 25 moves to the yarn pressing position to engage the yarns Y around the respective bobbins 20 (Fig. 1).

FIGURE 1

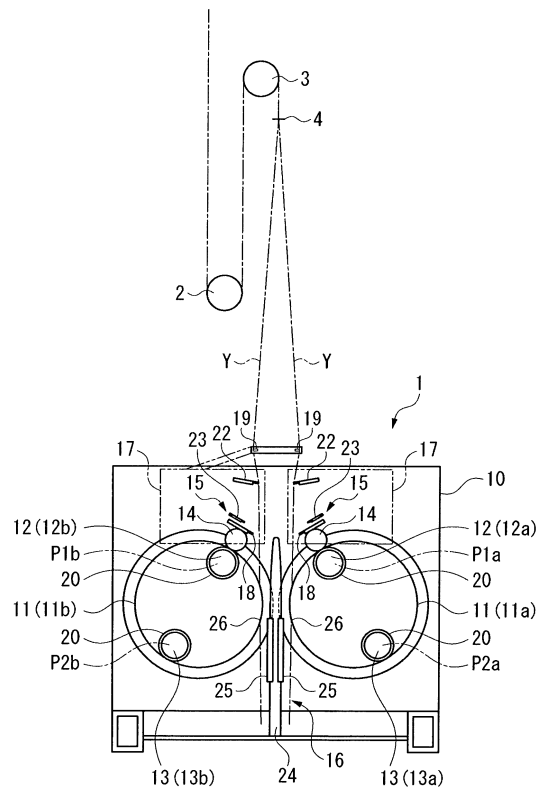

EP 1 995 201 A3



EUROPEAN SEARCH REPORT

Application Number
EP 08 00 8137

DOCUMENTS CONSIDERED TO BE RELEVANT			
Category	Citation of document with indication, where appropriate, of relevant passages	Relevant to claim	CLASSIFICATION OF THE APPLICATION (IPC)
X	DE 103 47 783 A1 (SAURER GMBH & CO KG [DE]) 12 May 2005 (2005-05-12) * paragraph [0026] - paragraph [0028] * * paragraph [0040] - paragraph [0044] * * figures 4.1, 4.2 * -----	1-3	INV. B65H67/048 B65H65/00 B65H54/72
X	DE 103 92 255 B4 (TSTM CO LTD [JP]) 19 October 2006 (2006-10-19) * paragraph [0030] - paragraph [0032] * * paragraph [0040] * * paragraph [0052] * * figures 1-3 * -----	1,2	
			TECHNICAL FIELDS SEARCHED (IPC)
			B65H
The present search report has been drawn up for all claims			
Place of search		Date of completion of the search	Examiner
The Hague		9 February 2012	Guisan, Thierry
CATEGORY OF CITED DOCUMENTS			
X : particularly relevant if taken alone Y : particularly relevant if combined with another document of the same category A : technological background O : non-written disclosure P : intermediate document		T : theory or principle underlying the invention E : earlier patent document, but published on, or after the filing date D : document cited in the application L : document cited for other reasons & : member of the same patent family, corresponding document	

1
EPO FORM 1503 03.82 (P04C01)

**ANNEX TO THE EUROPEAN SEARCH REPORT
ON EUROPEAN PATENT APPLICATION NO.**

EP 08 00 8137

This annex lists the patent family members relating to the patent documents cited in the above-mentioned European search report. The members are as contained in the European Patent Office EDP file on The European Patent Office is in no way liable for these particulars which are merely given for the purpose of information.

09-02-2012

Patent document cited in search report	Publication date	Patent family member(s)	Publication date
DE 10347783 A1	12-05-2005	NONE	

DE 10392255 B4	19-10-2006	AU 2003207230 A1	04-09-2003
		CN 1630613 A	22-06-2005
		DE 10392255 B4	19-10-2006
		DE 10392255 T5	07-07-2005
		JP 4128367 B2	30-07-2008
		JP 2003238031 A	27-08-2003
		TR 200402001 T2	22-11-2004
		WO 03068648 A1	21-08-2003

EPO FORM P0459

For more details about this annex : see Official Journal of the European Patent Office, No. 12/82