

H. Mauthe,

Brick Machine.

No. 104,330.

Patented June 14, 1870.

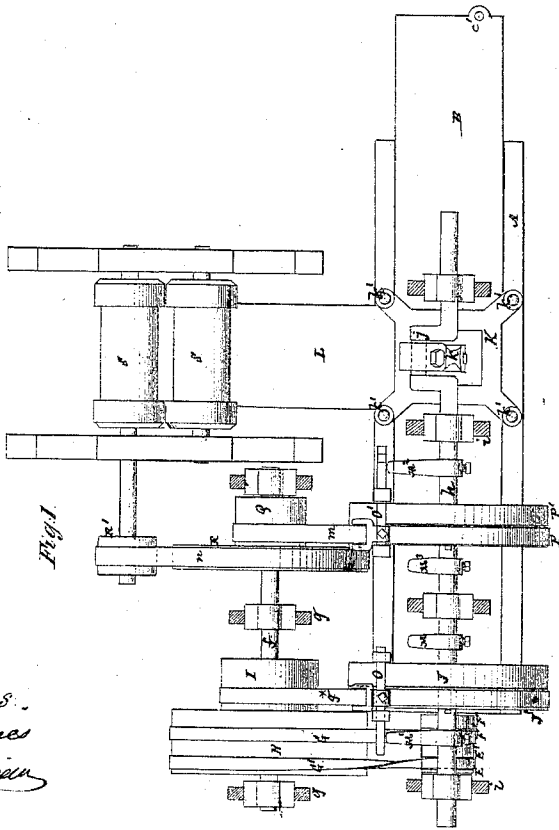
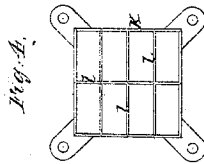

Witnesses:
 Fred. Haynes
 R. E. Rabear

Inventor:
 H. Mauthe

H. Mauthe,

2. Sheets. Sheet 2.

Brick Machine.

No. 104,330.

Patented June 14, 1870.

Fig. 3.

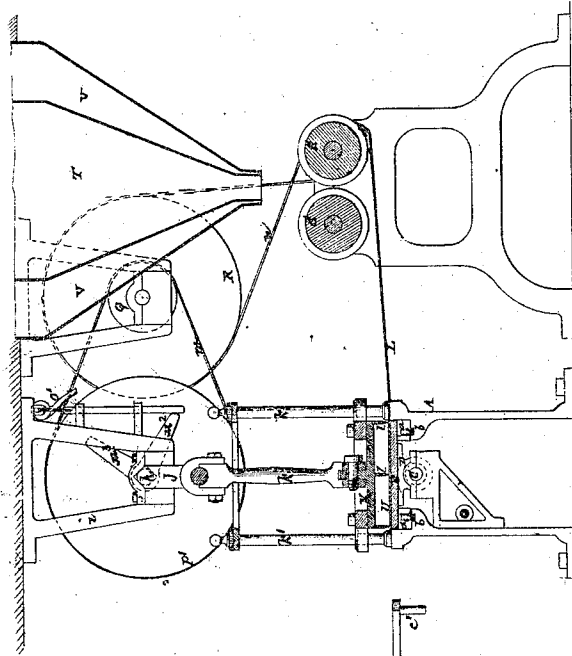
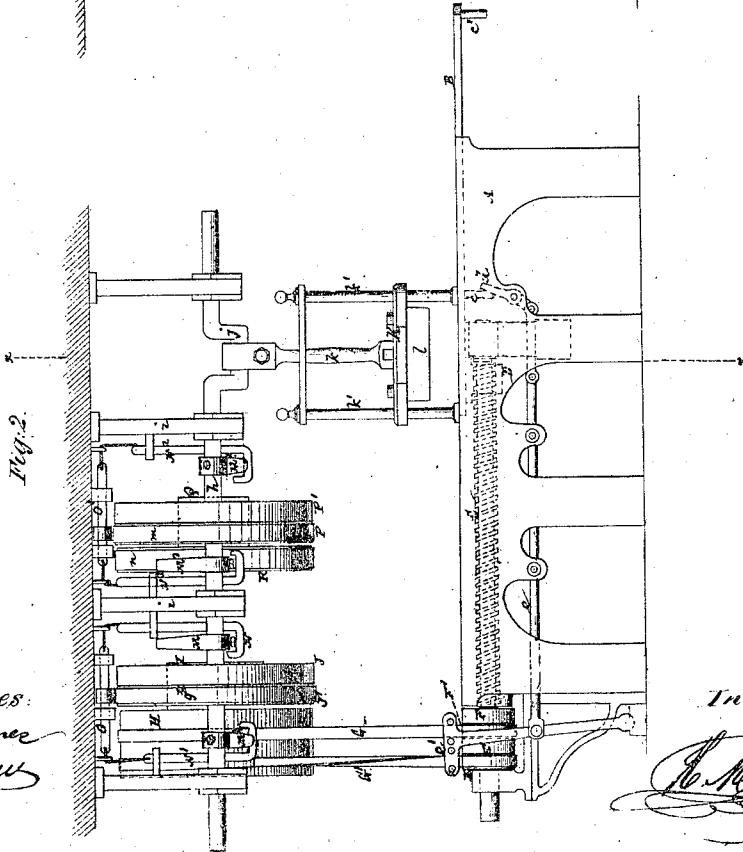

Fig. 2.



Witnesses:
Fred. Haynes
R. Chabaux

Inventor:

H. Mauthe

United States Patent Office.

HENRY MAUTHÉ, OF NEW YORK, N. Y., ASSIGNOR TO JULIEN LARRU, OF SAME PLACE.

Letters Patent No. 104,330, dated June 14, 1870.

IMPROVED BRICK-MACHINE.

The Schedule referred to in these Letters Patent and making part of the same

To all whom it may concern:

Be it known that I, HENRY MAUTHÉ, a subject of the Empire of France, but now a resident of New York, in the city, county, and State of New York, have invented a new and useful Improvement in Brick-Machines, of which the following is a full, clear, and exact description, reference being had to the accompanying drawing forming part of this specification, and in which—

Figure 1 represents a plan of a brick-machine constructed in accordance with my improvement;

Figure 2, a front or side view of the same;

Figure 3, a transverse section, taken as indicated by the line $x x$ in fig. 2; and

Figure 4, an under view of the presser and cutters, detached.

Similar letters of reference indicate corresponding parts.

My invention consists in certain combinations of devices or mechanism for making brick, in a rapid and perfect manner, from the clay in a sheet, by the action of a constantly-reciprocating presser, with cutters attached, and intermittently-reciprocating bed, the clay being automatically sanded as it issues from the hopper to crushing-rolls, which operate, in conjunction with a suitable table, to press and pass the clay in a sheet to the presser and cutters.

Referring to the accompanying drawing—

A represents the frame, which may be made of cast-iron.

B is an intermittently-reciprocating bed or platform, arranged to travel, by means of any suitable number of rollers, $a a$, on rails $b b$, secured to or forming part of the frame.

The platform is operated by a feed-screw, C, which is arranged under it, and works through a nut or box, D, secured to the platform, said screw turning in bearings at opposite ends, and, where it projects beyond one end of the frame, carrying four pulleys E E' F F', two of which, E and F, are fast, and the other two, E' and F', loose.

Motion is given to the screw C alternately, in reverse directions, at suitable intervals, by means of a straight belt, G, and cross-belt G', by or from a drum, H, accordingly as said belts are shifted to run on the fast or loose pulleys E E' F F'.

This is done automatically by means of two offsets $c c'$ from the under side of the platform, being made to strike alternately, on opposite sides, a lever, d , and so move, in reverse directions, a rod, e , which operates a belt-shifter, e' .

The drum H is fast on a shaft, f , running in hangers $g g$, and is driven by a belt, g^* , arranged to run upon a smaller drum, I, and passing over either a fast or loose pulley, J J', on a main driving-shaft, h .

The object of the fast and loose pulleys J J' is to secure to the screw C an intermittent motion in its reverse actions on the platform, during the movement of the latter in both or opposite directions.

The shaft h runs in hangers i , and, near one of its extremities, is made to form a crank, j , that serves to secure continuous up-and-down motion to a pitman, k , which works the presser and cutters or cutting-block K, that slides up and down guide-rods l , and is divided, upon its under face, into any desired number of knives or cutting-partitions, l , of the shape and size of the brick to be made.

Said cutting-block is arranged to play over the platform B, where the latter is joined by a feed-table, L, disposed to lie at right angles to the platform.

On the revolving main shaft h are secured, by set-screws, two arms M M', which serve, as they strike in timely order the lower bent ends of vertically-sliding bars N N', connected by cords passing over pulleys, through eyes, with a horizontally-sliding belt-shifting bar, O, to shift the belt g^* onto the one or the other of the fast and loose pulleys J J', and so to secure an intermittent motion to the screw C, in either or both directions of its travel.

On the main shaft h are also arranged two other fast and loose pulleys P P', over either of which, accordingly as it is shifted, passes a belt, m , which serves to drive a pulley, Q, on the shaft of which is a pulley, R, that operates, by a belt, n , and pulley R', the one of a pair of pressing-rolls, S S, that press the clay as it is delivered from a hopper, T, and pass it on to the table L, along which it is fed, in a sheet-form, on to the platform B, or on to each one in succession of a series of loose plates or boards, U, placed thereon to receive the brick as it is made by the cutting-block, and to facilitate the transfer of the brick, as made.

V V are sand-hoppers for holding and distributing sand on to the rolls and opposite sides of the clay passing therethrough, to prevent the clay sticking to the rolls or other parts in its passage through the machine, and to improve the manufacture of the brick.

The object of the fast and loose pulleys P P' is to give an intermittent action to the feed of the clay, or arrest of the feed at intervals, as required, and as hereinafter described.

The shifting of the belt m onto either pulley P P', alternately, to secure such intermittent action, is produced by arms M² M³ on the shaft h , acting, as they rotate, in a consecutive manner on the lower bent ends of a second pair of vertically-sliding bars, N² N³, connected, by cords, with a horizontally-sliding belt-shifting bar, O.

In the operation of the machine the clay is fed in a sheet, from over the table L, onto the plate or board U, in line with it, and the cutting-block K descends

to cut and form, or press a series of bricks, the platform B remaining stationary during such action, by the running of the driving-belt g^* on the loose pulley J; but as the block K, with its knives, leaves the clay, the arm M acts upon the bar N to shift the belt on to the feed-pulley J, which gives to the platform a feed the distance of one set of molds or cutting-partitions, forward or backward, according to which of the belts, G or G', the platform B has last shifted onto their fast pulleys E or F. Each time the platform is thus moving the cutting-block continues to rise, and makes a succeeding descent, but immediately before coming in contact with the clay again, the arm M¹ acts upon the bar N¹ to shift the belt g^* onto the loose pulley J, and to stop the motion of the platform.

This action is repeated continuously, and, by means of the arms M² M² acting successively on the bars N² N², a like timely intermittent action of the feed-rolls, relatively to the cutting-block, takes place, the feed stopping when the knives of the latter are entering or leaving the clay, by the shifting of the belt m onto the loose pulley P'. Thus the cutting-block K moves

continuously, while the feed of the clay and platform B is intermittent.

The reciprocating travel of the platform B, in being divided up into a succession of movements in both of its opposite directions, provides for the working or filling with brick, in rapid succession, of a series of plates or boards U, from opposite sides of the cutting presser-block.

What is here claimed, and desired to be secured by Letters Patent, is—

1. The combination of the clay-hopper T, sand-hoppers V V, pressing-rolls S S, cutting-block K, and table L, substantially as set forth.

2. The combination of the cutting-block K with the intermittently-moving and self-reversing platform B, the table L, and intermittently-operating rolls S S, arranged to operate substantially as described.

H. MAUTHÉ.

Witnesses:

FRED. HAYNES,
R. E. RABEAU.