

(No Model.)

2 Sheets—Sheet 1.

J. B. CURL.
SELF HEATING FLAT IRON.

No. 383,346.

Patented May 22, 1888.

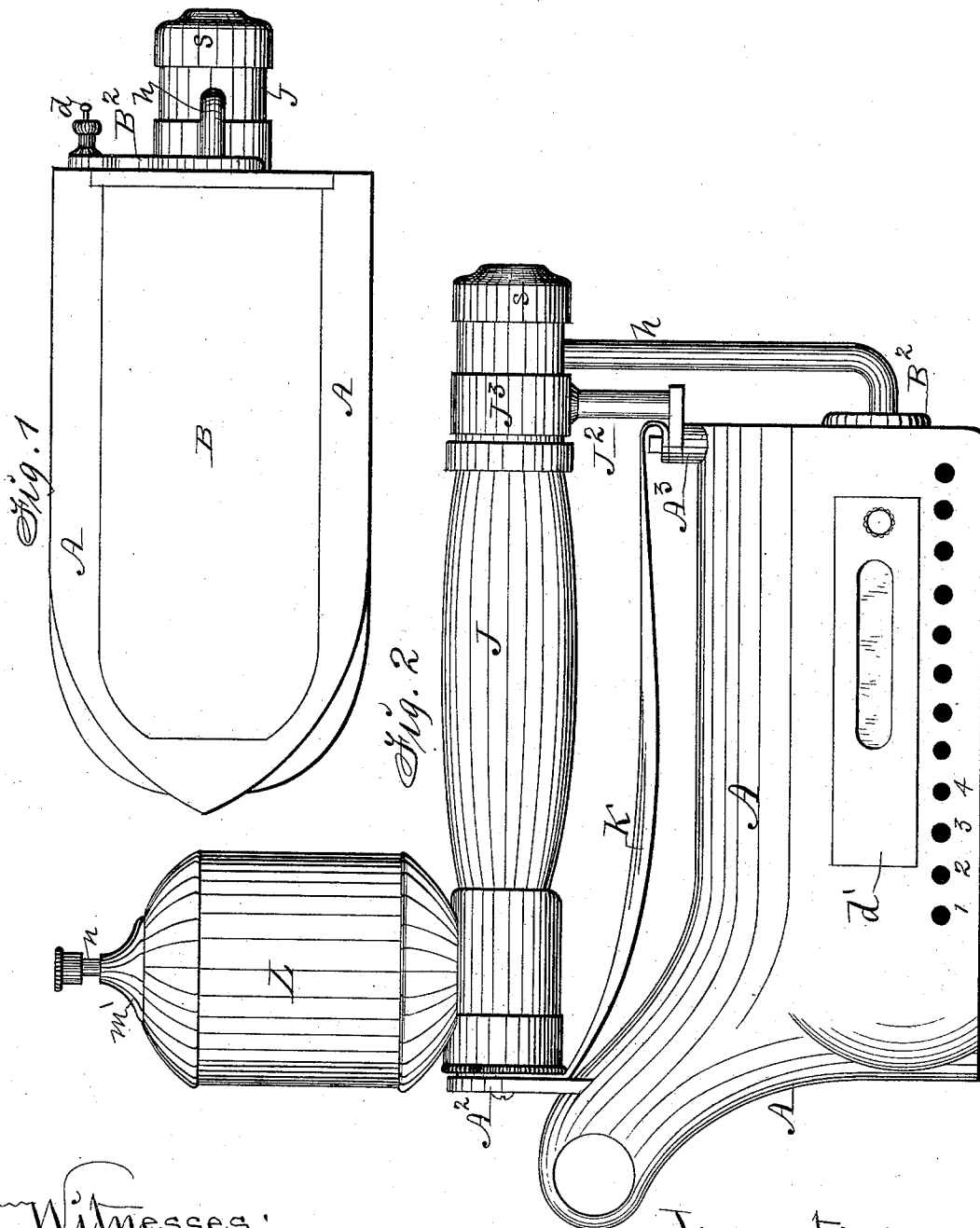

Witnesses:
 M. P. Smith
 J. C. Tate

Inventor:
 Jesse B. Curl,
 By Thomas G. Orwig, Atty.

(No Model.)

2 Sheets—Sheet 2

J. B. CURL.
SELF HEATING FLAT IRON.

No. 383,346.

Patented May 22, 1888.

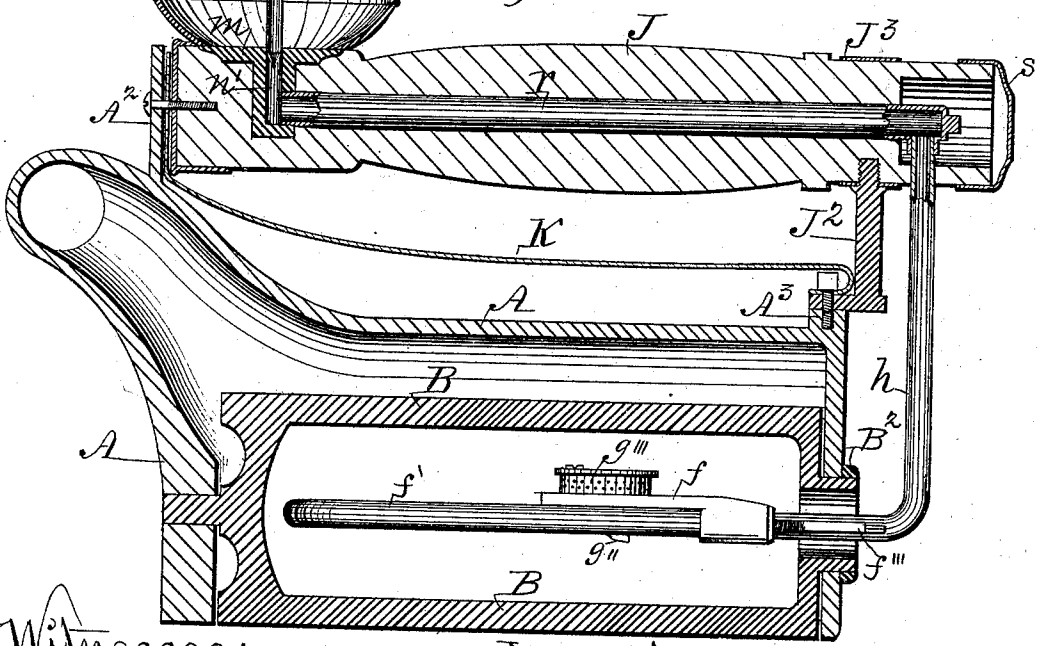
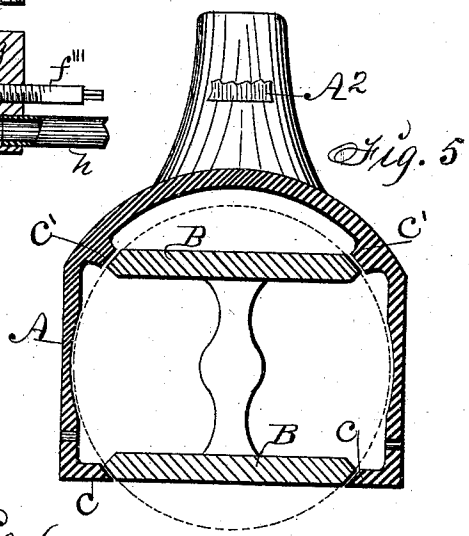
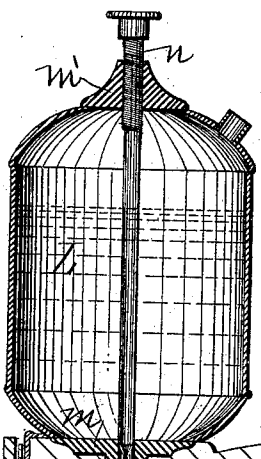
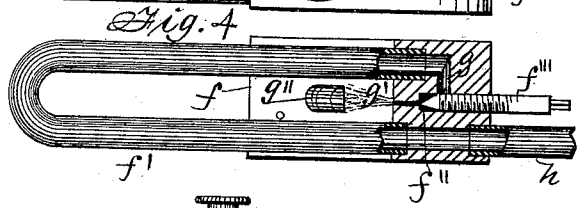
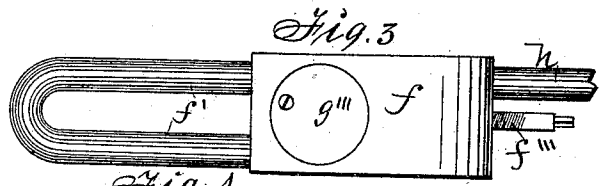

Witnesses:
M. P. Smith.
J. C. Tate

Inventor:
Jesse B. Curl,
By Thomas G. Orwig, Atty.

UNITED STATES PATENT OFFICE.

JESSE B. CURL, OF DES MOINES, IOWA.

SELF-HEATING FLAT-IRON.

SPECIFICATION forming part of Letters Patent No. 383,346, dated May 22, 1888.

Application filed August 30, 1887. Serial No. 248,295. (No model.)

To all whom it may concern:

Be it known that I, JESSE B. CURL, a citizen of the United States of America, and a resident of Des Moines, in the county of Polk and State of Iowa, have invented an Improved Self-Heating Flat-Iron, of which the following is a specification.

My invention consists in the construction and combination of a duplex revolving bottom, a vapor generator and burner, an oil-reservoir, and a handle, with a hollow open-bottomed iron, as hereinafter set forth, pointed out in my claim, and illustrated in the accompanying drawings, in which—

Figure 1 is a bottom view, and Fig. 2 a side view, of my improved iron. Fig. 3 is a top view, and Fig. 4 a bottom view, of my vapor generator and burner. Fig. 5 is a transverse view and Fig. 6 a longitudinal view, each taken through a central line.

A represents a cast-metal hollow and open-bottomed iron that may vary in dimensions, as desired. It has an integral tubular extension or chimney at its front end.

A² is a vertical projection at the top of the chimney, and A³ a projection at the top and rear of the iron, to which a wooden handle is attached.

B is my duplex revolving bottom, corresponding in size with the interior chamber and open bottom of the iron A. It has a solid journal on its front end and a hollow journal on its rear end, fitted in corresponding bearings in the ends of the iron, as clearly shown in Fig. 6, in such a manner that it can be readily revolved, as indicated by dotted lines in Fig. 5, by means of a crank, B², fixed to the end of the hollow journal at the rear end and outside of the iron A.

c c are flanges at the bottom of the iron, and c' flanges at the base of the roof, that project inward, as clearly shown in Fig. 5, to connect with the two revolving bottoms when they are in level horizontal position, as required to close the iron at the bottom and to produce a horizontal partition in the top portion of the iron that will serve as a deflector to direct the products of combustion forward and in contact with the under side of one of the parts of the revolving bottom, while at the same time a vacant space is retained under the roof that will prevent the top of the iron from becoming unduly heated.

d, shown in Fig. 1, represents a locking device in the form of a spring-actuated pin that extends through the crank-handle B² into a perforation in the end of the iron. To unlock the handle, I draw the pin outward to free its inner end from the iron.

d' is a door and window in the side of the iron, through which access is gained to the interior. A series of perforations, 1 2 3 4, under the door admit air to the burner inclosed within.

f is the cast-metal base of my vapor generator and burner. It has an enlargement at its rear end and under side, into which tubes are fitted, as clearly shown in Figs. 4 and 6.

f' is a coil or U-shaped tube that has its ends fitted and fixed in bores formed in the base, through which oil is conducted into the base to become heated and vaporized.

f'' represents a screw-seat and valve chamber, and f''' a valve fitted in said chamber to govern the flow of the fluid and the discharge of the vapor.

g is a bore that intersects the valve-chamber f'' and communicates with one end of the bent tube f'.

g' is a vent from which fluid and vapor are discharged from the valve-chamber f''.

g'' is an open-ended bent tube that extends through the metal base, to which it is fixed in such a manner that its open bottom end will be in line with the discharge-vent g'.

g''' is a perforated cap and burner fixed over the open top of the open tube g'', by means of a screw, in such a manner that the vapor will be distributed thereby and mixed with the air as required to be burned advantageously in maintaining a uniform heat in the iron.

h is an induction-tube, through which fluid is conveyed through a bore in the base f of the generator into the tube f', and from thence into the valve-chamber f'', formed in the said base f, as clearly shown in Fig. 4.

J is a wooden handle fixed to the projection A² by means of a screw and the projection A³ by means of a post, J², and a screw and a band, J³, as shown in Fig. 6.

K is a hand-shield jointly fastened with the handle J, as required, to protect the operator's hand.

L represents an oil-reservoir fixed on top of the front end of the wooden handle. It has a

cast-metal bottom, *m*, and a cast-metal top, *m'*, through which a screw or valve-stem, *n*, is extended into a vertical bore or valve-chamber, *n'*, formed in the bottom *m*, as clearly shown in Fig. 6, in such a manner that the flow of liquid from the reservoir can be readily governed thereby.

r is a straight tube extended through a bore in the wooden handle and screwed into a bore in the bottom *m* of the reservoir that intersects the vertical bore and valve-chamber *n'*. A square end on the straight tube and an enlargement of the bore in the wood facilitates the fastening of the tube by means of a wrench. A cap, *s*, fitted over the end of the wooden handle conceals the bore and tube. The elbow-shaped tube *h* is connected with the generator *f* at its lower end and with the tube *r* at its top end, as shown in Fig. 6.

In the practical use of my iron the flow of gasoline, or other suitable fluid, from the reservoir to the vapor-generator is readily controlled by means of the screw or valve *n* in the top of the reservoir, and the discharge of fluid and vapor from the generator is readily regulated by means of the screw or valve *f'''* in the end of the generator.

To start a fire, I open the valve *f'''* and allow a small quantity of fluid to flow and then light it with a match, so that the fluid will burn under the generator and heat and vaporize the fluid therein until it will begin to discharge vapor. I then, by means of the valve, regu-

late the discharge of the vapor as required to force it up through the tube *g''* into the burner *g'''*, from whence it will escape and burn as required to heat the upper portion of the duplex revolving bottom B; and when it is hot enough I reverse the position of the bottoms and utilize the heated one in a common way while the other one is becoming heated. The two bottoms can be thus successively heated and the iron continuously used by merely interchanging the positions of the connected revolving bottoms as long as there is fluid in the reservoir. To put out the fire, I simply close the valve in the generator.

I claim as my invention—

An improved self heating iron comprising an open-bottomed hollow iron having a chimney at its front end and journal-bearings at its opposite ends, a duplex bottom having journals on its ends and a crank on the end of one of said journals, a wooden handle having an oil-reservoir on its top connected by means of tubing with a vapor generator and burner located and concealed within the hollow iron and double revolving bottom, and valves for regulating the flow of fluid in the reservoir and in the vapor-generator, constructed, arranged, and combined to operate in the manner set forth.

JESSE B. CURL.

Witnesses:

MARTIN P. SMITH,
THOMAS G. ORWIG.