

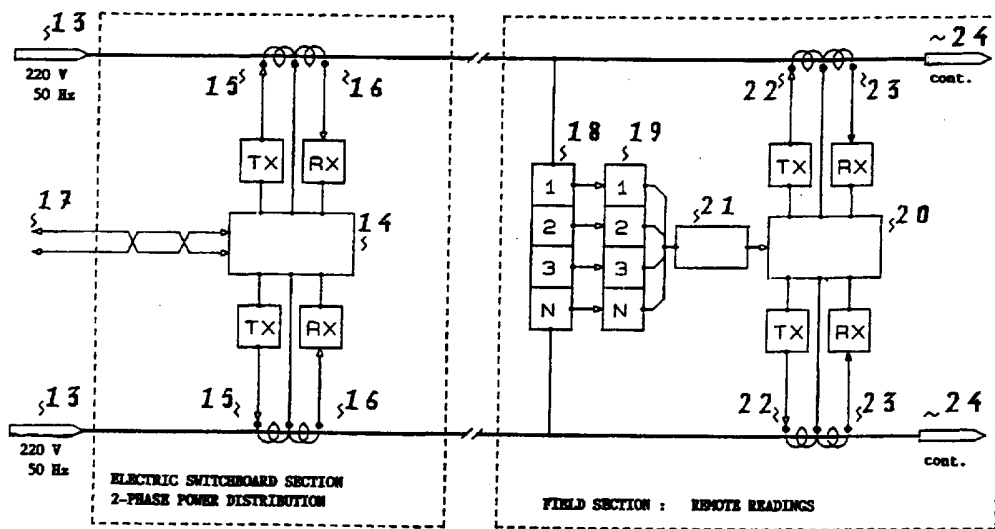

INTERNATIONAL APPLICATION PUBLISHED UNDER THE PATENT COOPERATION TREATY (PCT)

<p>(51) International Patent Classification ⁶ : H04B 3/54</p>	<p>A1</p>	<p>(11) International Publication Number: WO 97/31430 (43) International Publication Date: 28 August 1997 (28.08.97)</p>
<p>(21) International Application Number: PCT/IT97/00033 (22) International Filing Date: 20 February 1997 (20.02.97) (30) Priority Data: RM96A000116 21 February 1996 (21.02.96) IT (71) Applicant (for all designated States except US): TELOS TELECOMMUNICATIONS S.P.A. [IT/IT]; Via Lungomare di Pegli, 35, I-16155 Genova (IT). (72) Inventors; and (75) Inventors/Applicants (for US only): AIELLI, Florestano [IT/IT]; Viale Shakespeare, 71, I-00144 Roma (IT). MACCIONI, Ercole [IT/IT]; Via Monte di Malvaiato, 15/B, I-00060 Formello (IT). PETTAZZONI, Stefano [IT/IT]; Via Tarquinio Collatino, 191, I-00175 Roma (IT). (74) Agent: PERROTTA, Luciana; D. Perrotta & C. s.a.s., Corso Vittorio Emanuele II°, 21, I-00186 Roma (IT).</p>		<p>(81) Designated States: AL, AM, AU, BA, BB, BG, BR, CA, CN, CU, CZ, EE, GE, HU, IL, IS, JP, KG, KP, KR, LK, LR, LT, LV, MD, MG, MK, MN, MX, NO, NZ, PL, RO, SG, SI, SK, TR, TT, UA, US, UZ, VN, ARIPO patent (KE, LS, MW, SD, SZ, UG), Eurasian patent (AM, AZ, BY, KG, KZ, MD, RU, TJ, TM), European patent (AT, BE, CH, DE, DK, ES, FI, FR, GB, GR, IE, IT, LU, MC, NL, PT, SE), OAPI patent (BF, BJ, CF, CG, CI, CM, GA, GN, ML, MR, NE, SN, TD, TG).</p> <p>Published With international search report. Before the expiration of the time limit for amending the claims and to be republished in the event of the receipt of amendments.</p>

(54) Title: SYSTEM FOR DATA TRANSMISSION, REMOTE SENSING, REMOTE CONTROLS, REMOTE READINGS AND THE LIKE, PARTICULARLY SUITABLE FOR THE ELECTRIC POWER DISTRIBUTION LINES



(57) Abstract

Industrial invention of an electronic system able to use electric power supply lines, of parallel and/or series type, for transmitting data, remote sensing, remote controls, remote readings and the like. The system, called LDS (Line Data System) does not use modulated carrier power-line waves, but an original, fast and secure transmission technique which utilizes the same power supply lines without need for any modification or the adoption of costly components. The field units execute the commands emitted by the control and transmit back the data of the phenomena detected by means of transducers. More than one system can operate simultaneously for different uses on the same line without interfering with each other. Where the system uses the lines of a public lighting system the field detection units remain operational during the day hours without requiring the use of booster batteries.

FOR THE PURPOSES OF INFORMATION ONLY

Codes used to identify States party to the PCT on the front pages of pamphlets publishing international applications under the PCT.

AM	Armenia	GB	United Kingdom	MW	Malawi
AT	Austria	GE	Georgia	MX	Mexico
AU	Australia	GN	Guinea	NE	Niger
BB	Barbados	GR	Greece	NL	Netherlands
BE	Belgium	HU	Hungary	NO	Norway
BG	Burkina Faso	IE	Ireland	NZ	New Zealand
BG	Bulgaria	IT	Italy	PL	Poland
BJ	Benin	JP	Japan	PT	Portugal
BR	Brazil	KE	Kenya	RO	Romania
BY	Belarus	KG	Kyrgystan	RU	Russian Federation
CA	Canada	KP	Democratic People's Republic of Korea	SD	Sudan
CF	Central African Republic	KR	Republic of Korea	SE	Sweden
CG	Congo	KZ	Kazakhstan	SG	Singapore
CH	Switzerland	LI	Liechtenstein	SI	Slovenia
CI	Côte d'Ivoire	LK	Sri Lanka	SK	Slovakia
CM	Cameroon	LR	Liberia	SN	Senegal
CN	China	LT	Lithuania	SZ	Swaziland
CS	Czechoslovakia	LU	Luxembourg	TD	Chad
CZ	Czech Republic	LV	Latvia	TG	Togo
DE	Germany	MC	Monaco	TJ	Tajikistan
DK	Denmark	MD	Republic of Moldova	TT	Trinidad and Tobago
EE	Estonia	MG	Madagascar	UA	Ukraine
ES	Spain	ML	Mali	UG	Uganda
FI	Finland	MN	Mongolia	US	United States of America
FR	France	MR	Mauritania	UZ	Uzbekistan
GA	Gabon			VN	Viet Nam

DESCRIPTION

SYSTEM FOR DATA TRANSMISSION, REMOTE SENSING, REMOTE CONTROLS, REMOTE READINGS AND THE LIKE, PARTICULARLY SUITABLE FOR THE ELECTRIC POWER DISTRIBUTION LINES.

The current technique which uses for communications the same lighting and electric power distribution lines to provide the services listed in the abstract is superseded by the invention in question.

Glossary

To conform to the technical language certain terms have been abbreviated as specified here-under:

- Lines : Electric power supply lines;
- Sine wave : Sine wave and frequency at 50 Hz of the power supply Line current;
- Half-wave : Half-sine wave and frequency at 50 Hz of the power supply Line current;
- Control : Electronic unit with command functions;
- Station : Field unit;
- Tones : Unmodulated transmission frequencies;
- Block : Group of one or more Line Sine waves and/or Half-waves.

The inventors list certain major problems they have intended solving with this discovery called, for the sake of convenience, LDS (Line Data System):

1st Problem:

Obtain an innovative and speedy system which, for data communication, is able to use the existing parallel and/or series Lines with no need for modifications, and overcome the problems typical of Power -line Carrier (PLC) systems, among which the limited propagation and the possible radiofrequency radiation which creates interferences or disturbances on adjacent lines or to other systems. In fact the PLC transmission, which usually occurs between neutral grounded and the three phases united by unpredictable loads and high power factor capacitors, actually develops a typical unbalanced dipole, i.e. a real transmitting antenna which irradiates specially via the vertical supply conductors and the ground.

2nd Problem:

Necessity that the sensor Stations, when connected on a public lighting Line, continue to be fed and operational also during the hours when the luminaires are off, without having to use booster batteries or other support devices.

3rd Problem:

- 5 Necessity that the Stations communicate with the Control in Full-Duplex mode, minimizing the occupation of the spectrum of the allowed and available frequencies.

4th Problem:

- The problem concerns the economic aspect, i.e. the need to obtain a better
10 cost/performance ratio; this is obtained through the innovations of LDS which, not requiring any modifications of the power supply Lines, reduces investment costs.

TECHNICAL FIELD

- 15 In view of the original solutions of said problems, the LDS finds its ideal technical field (currently preferred by the inventors but nevertheless indicative and not limitative) wherever there is the opportunity to use the electric power distribution Lines to propose applications; these include at least 3 sectors: 1) Transport (detection and management of vehicular traffic); 2) Pollution (climate and
20 environmental data recording stations); 3) Management of electricity, gas, water, teleheating, etc. distribution networks.

- The wide extent and capillary expansion of the road network and distribution networks in the extra-urban and urban areas have created an insuperable economic barrier to the implementation of extensive and permeating monitoring and control
25 systems. This barrier is overcome through the opportunity offered by this invention. In fact LDS makes it possible to create extensive and capillary acquisition networks with extra-urban and urban area coverage concerning the acquisition and communication of elementary, congruent and isochronous data, thanks to the easiness with which the recording Stations can be applied to any type of Line to
30 implement the desired system.

INNOVATIVE TECHNICAL SOLUTIONS

- Substantially LDS is composed of two different types of electronic units. The first is
35 a Control unit and the second consists of the Sensor Stations for remote sensing, remote control and the like, to be installed in the field.

The units feature valid innovative solutions, the most important of which include:

1) **Synchrosys**: this concerns the original method synchronous with the Line frequency to send control data and codes to the field units (Fig. 6). The method, which uses un-modulated Tones, is managed by the Control units and uses the Line to obtain an extremely rugged and reliable communication system.

5 The data and commands can be addressed indifferently to one unit, to a group of units or to all the various families of units installed in the field that use the same Line. Said data and commands start, synchronize, stop, modify the operational parameters of the field units and the data managed by these units. LDS operates on any type of Line and more than one system can co-exist on the same Line, also for
10 different families and purposes, without any limitation and without interfering with one another.

The data and commands sent from the Control do not interrupt the stream of data that in the meantime the field sends to the Control unit.

2) **Synchrodata**: this concerns the original method of communication of the data
15 sent from the field towards the Control by means of Tones whose frequencies are not modulated (Fig. 4).

The operating principle is based on the employment of Tones inserted and synchronized with a Line Sine wave or Half-wave Block to communicate one Byte.

20 **The method**: The use of unmodulated frequencies, of the allowed and available range (also starting from the audio frequency range) and synchronous with the Line according to the Synchrosys and Synchrodata methods, permits communication protocols to be implemented, which are extremely simple and efficient when compared to the asynchronous types used by the PLC systems, as well as free from
25 interferences thanks to the signal (Tone) integration redundancy that can be effected by the receiver synchronously with the transmitter, thus avoiding the sending of parity Bits and/or the repetition of messages.

Thanks to the extreme reliability achievable in recognizing the presence of a known frequency Tone, it is possible to group and discriminate more Tones at the same
30 time in a 4 kHz bandwidth for example, to obtain a Full Duplex transmission channel according to this new technology method.

The use of base Tones at different frequencies allows having on the same Line more Control units which manage independently, concurrently, without reciprocal limitations and interferences, various Station arrays, each relating to one same
35 system or to different application systems.

The method makes it possible not only to contain the basic industrial costs, but also to reduce to a minimum the occupation of the allowed and available frequency range.

Lastly, since both Synchrodata and Synchrosys are synchronous with the line frequency, it is not necessary to introduce pauses between the sending of an elementary data and the next. Every instant of the Line time can be used to communicate data and commands (Figs. 4, 5 and 6).

5 In informatics terms, the method permits implementing a communication management protocol of the Token-Passing synchronous type with a pre-determined sequence in case of group or all-units scan. With this method both the Control and the Stations connected to it can manage the communication protocol transparently without occupying, for this management, part of the Line passband which thus
10 remains entirely available for the communication of data and commands .

Full Duplex: Synchrodata (Fig. 4) in conjunction with the Synchrosys command method (Fig. 6) have been invented to be used simultaneously with the advantage of obtaining an original and reliable method of bidirectional communication on the
15 Lines. At any moment the Control, using Tones other than those used by the Stations, is in a position to send towards its field units any Synchrosys communication without having to wait for the end of or to interrupt the flow of data such units are communicating to the Control.

20 **4) Smartpower:** "Smartpower" features the original method whereby the sensor Stations, when installed on a public lighting system, remain fed and thus operational also whith the luminaires switched off, with no need for autonomous supply. To obtain this result it was conceived to insert into the Line a low operating voltage which, while being capable of feeding the sensor Stations, is insufficient to trigger
25 the Starters of the Lamps and permits maintenance interventions.

5) Economic benefits: The LDS system satisfies both application and economy demands in that it permits, using the existing Lines as they are, to implement monitoring and control systems extended over all the area served by the road
30 network and the power, gas and water distribution networks. LDS can be viewed as one of the most original, innovative, economic and practical inventions, systems, methods or utilities known at present.

BACKGROUND ART

35

All the techniques in use so far involve heavy investments for implementation of the necessary infrastructures, and high maintenance costs; this has obliged, until now, to

limit the applications only to the most important distribution network nodes. The known techniques include:

5 A) **Accessory conductors:** Systems based on the use of accessory conductors to be installed beside the Lines. This method represents an apparently simple solution; however, it is costly as to both initial investments - in that the cables must meet precise isolation norms - and the additional maintenance costs linked to the vulnerability of the system due to the operational context: "The road".

10 B) **Radio or telephone communications:** Systems that use radio units, dedicated telephone lines or similar solutions, are exposed to the same problems as the accessory conductors.

15 C) **Power-Line Carrier :** Systems that use modulated waves on the Line. They are very susceptible to Line disturbances and electric impediments and thus require sophisticated management protocols capable of recognizing any data losses and of generating related message repetition. This results in higher complexity and cost of the systems based on this technique as well as a reduced capacity of data transport with respect to the theoretical values and the need for a cautious consideration of communication times. Furthermore, it is necessary to preliminarily check, for each cable to be used, that the passband and the group delay of each cable are congruent
20 with the frequency of emission and depth of modulation

Moreover, in view of the reduced capacity of propagation of said signals owing to a lower capacitive reactance due to the necessity to use higher frequencies with respect to the LDS system, it is not possible to reach the necessary operating distances without the use of intermediate amplifications or the repetition of the
25 signals.

D) **DTMF (Dual Tone Multifrequency):** this is a call-routing telephone system which employs 2 tones at a time out of 8 available and is thus able to supply 16 different values.

30 At times it is employed to communicate data and to send commands, both baseband and as carrier modulator but, owing to its limitations, it cannot be assimilated to the LDS system which, though employing one Tone at a time, is able to be faster and to transfer any Bytes configuration.

35 SYSTEM DESCRIPTION

System for data transmission, remote sensing, remote controls, remote readings and the like, particularly suitable for the electric power distribution lines, forming the object of this document.

The system has been invented to overcome the problems of the present technologies and to be easily produced and installed by all interested parties with the result - as will be seen further on - of obtaining a more secure method of performance; the LDS invention furthermore, is the most economic of any system known so far.

The general architecture of the LDS system is organized on 3 levels, as follows:

1st Level: Supervision Centre

This consists of a unit or system upstream the LDS Control(s) which, being conventional, is not claimable but nevertheless is included to have complete drawings for universal use of the LDS system.

2nd Level: Control

This consists of one or more electronic units, intelligent and capable of managing, dialoguing with and receiving data from the field units. More Control units can depend on a same Supervision Centre but can also operate independently and autonomously.

3rd Level: Stations

This level consists of field electronic units, intelligent and adaptable to multiple uses, capable of managing one or more transducers of different nature for remote sensing, remote control and the like according to the various user demands. The Stations, when installed on a public lighting system, can function also during the hours when the luminaires are off without need for booster batteries or other support systems. The various sections composing a Station are contained in a sealed, eventually thermostated box, of pole or wall type, which can supply the voltages and currents required for the various types of transducers used.

LIST OF DRAWINGS

The invention submitted now deals with the perfect description of the system and the major innovative solutions conceived concerning the following original methods:

- 1) Synchrosys, for sending synchronous data and commands;
 - 2) Synchrodata, for data communication;
 - 3) Smartpower, for day-time operation.
- Lastly, a clear description is provided of all the basic elements of the unit so that, thanks to the technical knowledge this documentation is able to offer, it is in fact possible for an expert to reproduce the invention.

It is understood that the following description, concerning the development, technical description and operation of the LDS system summarizes the version preferred by the inventors; however, nothing prevents that, based on the philosophy of the invention or on what suggested by the explained and/or exemplified solutions, the invention be developed and exploited, even in part and/or by derivation, industrially and economically in other manners and in different fields of application.

Fig.1 Shows the general block diagram of the system for remote sensing and remote control;

Fig.2 Shows the general block diagram of the system for the remote reading of meters;

Fig.3 Shows an application of the system between an individual phase and neutral;

Fig.4 Depicts the waveforms of the high speed Synchrodata communication;

Fig.5 Depicts the waveforms of the low speed Synchrodata communication;

Fig.6 Depicts the waveforms of the Synchronous command code by employing unmodulated Tones, synchronous with the Line Sine waves;

Fig.7 Shows the block diagram of the Control unit;

Fig.8 Shows the block diagram of a typical field Station.

DESCRIPTION OF DRAWINGS

For the sake of clarity the electric circuits have been described using discrete components; nevertheless the concept is claimed even though programmable wide-integration components (Gate Arrays, Microprocessors or other similar components) are used.

Only the more significant parts of the units are described and all the examples, not limitative, are referred to 220 Volt, 50 Hz electric circuit supply voltage. The concepts illustrated are valid also for use with other types of components and different voltage and frequency values.

Fig. 1 Shows the general block diagram of the LDS system dedicated to sensing and remote control when installed on a public lighting system. The diagram is divided into two sections: In the "Power Delivery Point Section" is grouped the Control unit and in the "Field Section" are grouped the field units.

On the left the incoming Line supply (1) and the power factor capacitor (2) eventually present upstream the LDS system are noted.

The Teledeflectors (3), are needed to insert the low voltage, 50 Hz Smartpower supply (4) to feed the Stations in the absence of the 220 Volt primary energy.

The low voltage power supply applied to the Line does not concern the installed public lighting luminaires which thus remain disconnected. Such power supply voltage for the recording Stations (9) is inserted during the hours when the luminaires are switched off. In fact, normally the Teledeflectors (3) are kept closed
5 on the contacts towards the 220 Volt power supply. Upon lack of said power supply the Teledeflectors automatically switch on the standby contacts and introduce the low voltage supplied by (4).

Control: The Control unit (5) sends the commands to the field via the induction circuit (6), one for each supply phase, and collects the data coming from the field
10 through an equal number of induction circuits (7) without connecting physically on the Line. Lastly, it communicates with an eventual Supervision Centre via a data transmission line (8).

Field: The lighting luminaires and relevant lamps, usually fed between phase and neutral, are not shown in that they do not pertain to the subject-matters in question.
15 The section shows only one sensor Station (9) provided with active and/or passive detection transducers (10) and remote control outputs (11) for actuators and/or display devices, and finally the Line (12) proceeds towards the other units. It is well visible that the sensor Station of the Field Section communicates with the Control unit (5) solely via the same Line.

20 **Fig. 2** shows the general block diagram of the LDS system where employed on phase to phase distribution networks. This type of connection permits also to translate the communication of data and commands between the medium voltage secondary and primary of a transformer.

The exemplified diagram, relating to the remote reading of meters, is divided into
25 two sections: the "Electric Switchboard Section" groups the Control unit and the "Field Section" the field unit.

On the left the presence is noted of the single-phase 220 Volt Line supply (13) present in the Electric Switchboard. The same concept is valid for the other two phases not shown in the drawing for the sake of simplicity of display.

30 **Section" the field units.**

The Control unit (14) sends the commands to the field via two induction circuits (15) and receives the data via two detection circuits (16) with which it obtains also the Line synchronism at 50 Hz.

It shall be noted that the Control does not act directly on the Line current, from
35 which however it is galvanically isolated.

On the right a column of counters (18) and respective transducers for their reading (19) is shown.

The reading Station (20) reads the values indicated by the transducers via a Demultiplexer (21) and keeps them in storage; it receives the commands emitted by the Control (14) via the detection circuits (23) and sends the data detected to the Control (14) via the induction circuits (22).

Performance: As a way of example the comparison is provided between the LDS system which employs a 1,600 Hz Tone and a PLC system which employs an 80 KHz frequency to transmit on a phase-to-phase distribution circuit.

Provided that, due to the different communication protocols intrinsic in the two systems (Synchronous that of LDS, asynchronous that of the PLCs), the LDS system can transfer, at equal time period, many more useful data than a PLC system with 1,200 bps communication speed, it must be borne in mind that, to evaluate the power needed to transmit long distance on low voltage Lines, it is necessary to take into account the presence of power factor capacitors.

Assuming that each capacitor has a nominal value of 8 μF and that the overall installed capacitance is 800 μF (for each phase), the relationship between the attenuations will be as follows:

- For a Tone of the LDS system at 1,600 Hz:

$$[1] X_{\text{CLDS}} = 1 : (2\pi \cdot F \cdot C) = 1 : (2\pi \cdot 1,600 \cdot 800 \cdot 10^{-6}) = 0.125\Omega$$

- For a PLC system at 80 kHz:

$$[2] X_{\text{C80K}} = 1 : (2\pi \cdot F \cdot C) = 1 : (2\pi \cdot 80 \cdot 10^3 \cdot 800 \cdot 10^{-6}) = 0.002,500\Omega$$

The dB attenuation ratio between the LDS system and the 80 kHz system, due to the capacitive load of the power factor correction capacitors is disadvantageous for the 80 kHz PLC system, being:

$$[3] 20 \text{Log}_{10} (X_{\text{C80K}} : X_{\text{CLDS}}) = -33.9 \text{ dB}$$

It follows that to obtain a voltage V_{rms} efficient by at least 0.050 Volts, the following transmission induced currents I_{80K} and I_{LDS} are required:

- For a Tone of the LDS system at 1,600 Hz:

$$[4] I_{\text{LDS}} = (V_{\text{rms}} : X_{\text{CLDS}}) = (0.050 : 0.125) = 0.4 \text{ Amperes};$$

Equal to 0.020 Watt power

- For a PLC system at 80 kHz.

$$[5] I_{80K} = (V_{\text{rms}} : X_{\text{C80K}}) = (0.050 : 0.002,500) = 20 \text{ Amperes};$$

Equal to 1 Watt power

Since the ratio between the two powers (Watt) = 16.9 dB, it follows that if the LDS system employed the same 20 Ampere induced current I_{80K} , it would exceed by at least 5 times the propagation attainable by an 80 kHz system like that shown in the example. Therefore, in terms of performance, the LDS system can permit a better propagation and a greater transport of useful data at equal time period.

Fig. 3 depicts the use of LDS on single phase and neutral power distribution networks, a pattern usually used by the PLC systems.

(25) Three-phase medium voltage power supply;

(26) Three-phase medium/low voltage transformer;

(27) RX-TX induction circuit of the Control;

(28) Control;

(29) Station;

(30) RX-TX induction circuit of the Station;

(31) Stray capacitances towards ground distributed along the Lines.

To evaluate the power needed to transmit with such method on long distances it is necessary to consider the attenuation caused by the stray capacitances (31) distributed among the 3 energy conductors and the neutral referred to ground.

The Ω value of capacitive reactance X_C represents the stray load which induces the attenuation of the signals.

As a way of example the comparison is provided between the performance of the LDS system that employs a 1,600 Hz Tone and a PLC system having the following characteristics:

- V_{TX} 2 Volts transmission rms voltage

- V_{RX} 0.01 Volts reception rms voltage

- W_{TX} 1 Watt transmission rms power

- F_{TX} 72 kHz transmission frequency

In this situation we will have:

- Transmission current I_{TX} :

$$[6] I_{TX} = W_{TX} : V_{TX} = 1 : 2 = 0.5 \text{ Amperes}$$

- Load capacitive reactance X_C :

$$[7] X_{C \text{ PLC}} = V_{TX} : I_{TX} = 2 : 0.5 = 4 \Omega$$

- Value of distributed capacitance C (31):

$$[8] C = 1 : (2\pi \cdot F_{TX} \cdot X_C) = 1 : (2\pi \cdot 72 \cdot 10^3 \cdot 4) = 0.552 \mu\text{F}$$

- dB attenuation between the rms level of the received signal V_{RX} and the transmitted signal V_{TX} :

$$[9] 20 \text{ Log}_{10} (V_{RX} : V_{TX}) = 20 \text{ Log}_{10} (0.01 : 2) = -46 \text{ dB}$$

In the case of LDS with a 1,600 Hz Tone, we will obtain:

- Load capacitive reactance:

$$[10] X_{C \text{ LDS}} = 1 : (2\pi \cdot F_{TX} \cdot C) = 1 : (2\pi \cdot 1,600 \cdot 0.552 \cdot 10^{-6}) = 180 \Omega$$

The attenuation ratio between the two systems (PLC/LDS) is to the detriment of the PLCs and is:

$$[11] 20 \text{ Log}_{10} (X_{C \text{ PLC}} : X_{C \text{ LDS}}) = 20 \text{ Log}_{10} (4 : 180) = -33 \text{ dB}$$

It follows that, due to the different attenuation, the LDS system is able to ensure a propagation more than 5 times greater than that supplied by the PLCs.

Fig. 4 illustrates the electric diagram of the Synchrodata communication code waveforms.

- 15 The principle upon which the communication is founded from the various field units to the Control unit consists in the modulation of the current of a Block of Sine waves by means of unmodulated Tones transmitted synchronously with the Sine waves. Recognition of the data coming from a given field unit occurs according to the principle that both the Control unit and all the field units are connected to the Line
- 20 Sine waves and are provided with 50 Hz counters started and synchronized by an appropriate Start signal emitted by a logic section of the Control (Figs. 6 and 7). Starting from this Start signal the counters of all the units are zeroed simultaneously and will start step counting starting from the same Sine wave. In the event that more than one unit (one group or all) has been addressed, each unit will transmit in turn,
- 25 according to the sequential order established upon installation, i.e. at the moment when the 50 Hz synchronous counting will correspond to the Block of Sine waves assigned as group sequence or Stations array sequence.

By exploiting the synchronism offered by the Line sine wave current, virtually free from disturbances given the considerable power in play, the system is able to

30 maintain the 50 Hz Control counters constantly synchronized with those of the field units.

By analyzing the sequence of the various Blocks of Sine waves with identical counting system of the Stations and by recognizing the Tone sent in each segment of the Block, the Control is able to reconstruct the binary content of the

35 communication made by the field unit, and recognizes its source.

The three parentheses (33), (34) and (35) show examples of various Blocks; other cases can be developed maintaining the same principle of synchrony which is the essential object of this new technology.

Line (32) shows the 50 Hz Line Sine waves;

- 40 In the parentheses, sign (+) indicates the positive Half-waves and sign (-) the negative Half-waves;

Each letter "R" shows the Result of the communication which is obtained according to the position of the Tones in the Sine waves or in the Half-waves;

- 45 Parenthesis (33) depicts the case where each field unit is assigned 4 Line Sine waves to transmit a Byte using 4 different Tones. Unit 1 is assigned Block 1 which comprises Sine waves 1 to 4; Unit 2 is assigned Block 2 which includes Sine waves 5 to 8, and so forth.

For the examples of the diagram the following values have been chosen for each Bit pair of the Byte:

- 1) Tone "A" = "0 0" binary value
- 2) Tone "B" = "0 1" binary value
- 3) Tone "C" = "1 0" binary value
- 4) Tone "D" = "1 1" binary value

In accordance with the binary value of each Bit pair of the Byte to be communicated, one of the 4 reference Tones is chosen and with it is modulated the Line current for the duration of one Sine wave.

Block 3, composed of Sine waves 9, 10, 11 and 12 of said parenthesis (33), provides an example of the above-mentioned 4 Tone method. In fact, the same result can be attained by employing only 3 Tones and associating to the no-Tone the "0 0" binary value, for example. Therefore, in the example, the no-Tone = Tone "A" of the two previous Blocks.

Parenthesis (34) shows how to use the method in the event that a higher communication speed is needed. In this case the duration of the Line current modulation is reduced to only one Half-wave for each Tone, thus obtaining the possibility of communicating one Byte with 2 Sine waves, 2 Bytes with 4 Sine waves, and so forth.

The same 3 Tone (33) 3rd Block method is applicable also in this case as shown at the 3rd Block relating to Sine waves 5 and 6.

Parenthesis (35) shows how to use the method in case of a slower communication specially suitable, for example, for remote reading of slowly varying consumption meters. In this situation it is possible to use Tones of lower frequency and to prolongue the modulation of the Line current for 2 or more 50 Hz Sine waves, as better detailed in Fig. 5.

Extensibility: For the sake of space and simplicity, the examples show that each unit communicates only one Byte.

In general the method permits to communicate any number of Bytes, one after the other, until the necessary length of the message is reached.

Dependent on the performance required and the frequencies chosen for the Tones, the Line current can be modulated for the period of one Half-wave or fraction of it or, of one Sine wave or multiple of it.

A Tone can be used according to a binary logic 1/0 so that its presence/absence in a Block element allows sending and receiving the state of each of the Bits of one Byte.

Assuming instead to have more elementary Tones available, it will be possible to associate to each binary configuration of n Bits a specific Tone, thereby obtaining

increasingly faster communication techniques as the value of n increases in that, at equal time, it will be possible to transfer increasingly greater parts of a Byte.

In this case, if " n " is the value of n Bits, it will be necessary to have an NT number of elementary Tones:

[12] $NT = 2^n$

There is the possibility of reducing such number to value:

[13] $NT_o = 2^n - 1$

using, as significant information, also the no-Tone to which can be associated, for example, the value = 0; the following table will be obtained:

□	1	2	3	4	5	6	7	8
□								
n								
NT	2	4	8	16	32	64	128	256
NT _o	1	3	7	15	31	63	127	255

Having, for example, 255 different elementary Tones, it would be possible to communicate any value of a Byte in one unit of time while, having only one Tone, 8 time units will be needed to obtain the same communication.

- 15 The optimal choice will be made by balancing the desired performance and the basic complexity of the system.

Determination of the elementary time unit: Half-wave or fraction/Sine wave or multiple, will be made on the basis of the frequencies chosen as base Tones and the redundancy needed to reach the desired communication reliability.

- 20 Fig. 5 explains better than the previous figure the waveforms of the low-speed Synchrodata method of communication, particularly suitable for monitoring systems regarding phenomena characterized by low variation speed. The adoption of Tones of appropriate frequency, associated to the presence of a Tone for multiple Sine waves, allows obtaining a communication free from disturbances thanks to the
- 25 signal integration redundancy that can be effected by the receiver.

Line (36) shows the 50 Hz Line Sine waves;

Line (37) shows the frequency "A" Tone which prolongues for 10 Sine waves and, for lack of space, a portion of the Tone "B" duration, and so forth;

Line (38) shows the Tone "A" integration upon reception;

- 30 Line (39) shows the beginning of the Tone "B" integration upon reception;

Line (40) shows the moment in which the transmit/receive Tone is identified;

The present example follows the same concepts as Fig. 3 as regards performance and possibility for expansion.

Fig. 6 illustrates the electric diagram of the waveforms of the Synchronsis code formulated and emitted by the Control for the command of the field units. It shall be noted that the current of a Line Sine waves series is modulated to generate binary codes corresponding to:

- - Start Signal
- - Encoded commands
- - Identification of the addressed devices (Individual and/or group)
- - Any other code/data following the previous and omitted for ease of display.

The method thus converts the 50 Hz Line low frequency into a brief and fast binary code which can be sent on the Line independently from the flow of data the field units are sending to the Control.

By using one or more unmodulated Tones, the Control can generate on the Line a powerful, complete and composite message able to satisfy any data and command communication requirement.

- The module that formulates the Code is contained in the Control unit which sends it via the induction circuits (see Figs. 1 and 2) which insert the Tone current synchronously with the Line Sine waves. The Start command emitted by a Control will synchronize only and solely all the field units relating to the application system controlled by it.
- As a way of example, not limitative, a Synchronsis code diagram is shown, dimensioned for 16 commands and 64 addresses, but nothing prevents the concept from being reduced or expanded as needed. The code shown in the diagram uses a Block of 12 Sine waves configured as follows:
 - * Start signal at 2 Bits;
 - * Command code at 4 Bits;
 - * Address code at 6 Bits.

Line (41 - A) shows the 50 Hz Line Sine waves;

Line (41 - B) shows the command code obtained by direct modulation of the Line current, particularly suitable for the Stations installed on public lighting systems;

- **Line (41 - C)** shows the command code obtained by indirect modulation of the Line current, particularly suitable for the Stations installed on other distribution networks;

- The code starts with the Start command formulated, in the example, with the use of the Tone in an "ON" Sine wave and one "OFF". This is followed by the command code and the address of the field unit to which the command is addressed. Line (41) represents the command as emitted by the Control, while the subsequent lines (42/49) show how said command is elaborated upon reception and detected by the field Stations.

The Tone used for the Start signal can be different from the Tones used for communication of data, commands and addresses.

Line (42) shows the result of the integration of the Tone. It shall be noted that the logic level is always high in the presence of the Tone ("ON" State) and low in the moments when instead the Tone is missing ("OFF" State);

Line (43) shows the 50 Hz continuous Clock reproduced locally. This continuous form is furnished by the local system of generation compared and synchronized in phase with the Line Sine waves;

Line (44) shows continuous pulses, shorter and shifted in phase towards the end of each positive Half-wave. Each pulse is used to detect the absence or presence of the Tone in each Half-wave.

For ease of display the code shown in the example relates only to the positive Half-waves, but the same is done with the negative Half-waves and the two Results compared and summed up as per Results (46, 47, 48 and 49).

Line (45) shows the output furnished by a comparator circuit AND (omitted) by comparing the previous levels of the forms (42, 43 and 44);

Line (46) displays the Result of the Start command in the established interval of time;

Line (47) shows the control of the duration of the communication cycle of the full code, command and address, which begins at the end of the Start command (46) and extends for the time established up to the 12th Sine wave in the example;

Line (48) displays the Result of the command code in the assigned time interval (4 Sine waves following the Start command);

Line (49) displays the Result of the field unit address code. The message will be received by all the stations operationally connected to the Control that has emitted the command: All those enabled to receive the commands on that specific frequency of Tone, but only the addressed Station(s) will execute it starting from the end of the communication cycle: 13th Sine wave, in the example.

Fig. 7 shows the block diagram of the Control unit divided into 4 sections: Address Counters; Tone Reception; Transmitter and Logic sections.

Address Counters section: its task is to count the 50 Hz Sine waves through:

- (50) Detection circuits;
- (51) Circuit for collecting and squaring the 50 Hz Line synchronization pulses supplied by the detection circuits (50), and command recognition circuit;
- (52) 50 Hz prescaler to obtain the Block;
- (53) Decimal counter of the units;
- (54) Decimal counter of the tens;
- (55) Decimal counter of the hundreds;

(56) AND matrix to determine the address of the Station that is sending the data coming from the field.

Tone reception: The example shows the case of a 4 Tone Synchrodata communication. The task of the section is to separate and detect the Tones received through:

(57) Circuit for collection and preamplification of the Tones acquired through the detection circuits (50);

(58) Tone treatment and squaring circuit;

(59) Tone "A" detector;

10 (60) Tone "B" detector;

(61) Tone "C" detector;

(62) Tone "D" detector;

(63) Demultiplexer.

Logic section: Its task is to manage all the unit via:

15 (64) Microcontroller (hereinafter: "CPU");

(65) Supply to the CPU (64) of the 50 Hz synchronism collected from the detection circuits (50);

Transmitter section: Its task is to send the commands to all the Stations operationally connected to the Control, in a balanced way on the two phases:

20 (66) First Push-Pull driver for the Tone transmission of the command code ;

(67) Second Push-Pull driver in phase opposition to the previous for the Tone transmission of the command code ;

(68) Induction circuit of the command code.

25 **Description:** The CPU (64) collects from the matrix (56) the address of the Station which is sending the data from the field. This determination occurs by means of the 50 Hz counters and on the basis of the multiples of the number of Sine waves established for each Block, as shown in Fig. 4 (33, 34 and 35).

The CPU, synchronously with the 50 Hz Line through the circuit (65), actuates the Demultiplexer (63) to know which Tone is present in each Sine wave or Half-wave 30 composing each Block.

Based on the Tones present in each Block element the CPU is able to reconstruct the binary content of the information sent by the Station whose address is that determined by the circuit (56).

35 For transmission of the commands the CPU enables the Push-Pull circuits (66 and 67) which function as current Drivers for the induction circuits (68).

Through the interface (69) (optional) the CPU sends the data to the eventual Supervision Centre via a line or coaxial cable (70).

Fig. 8 shows the block diagram of a typical field Station divided for simplicity into 3 sections: Address Counters; Oscillator and Logic.

Address Counters section

The task of the address counters section is to count the 50 Hz Sine waves through:

- 15 (71) 50 Hz prescaler to obtain the Block;
- (72) decimal counter of the Units;
- (73) decimal counter of the Tens;
- (74) decimal counter of the Hundreds;
- (75) decoding matrix AND for the communication turn; Storage of the Station
- 20 address numbers assigned upon installation.

Logic section

The task of the logic section is to manage all the Control unit through:

- (76) Microcontroller (hereinafter: CPU);
- (77) Circuit of supply of the 50 Hz synchronizing pulses and detection of the
- 25 command code;
- (78) Demultiplexer, to select and separate the Tone to be sent to transmission;
- (79) AND circuit to send to transmission the communication Tones;
- (80) Transmitter;
- (81) Induction circuit;
- 30 (82) Transducers interface;
- (83) Driver circuit to actuate the remote controls.

Oscillator: The task of the oscillator is to produce the Clock for the CPU and to generate the communication Tones which, in the explicative and not limitative example, are 4, through:

- 35 (84) Oscillator circuit synchronized with the 50 Hz Line Sine waves;
- (85) Divider for Tone "A";
- (86) Divider for Tone "B";
- (87) Divider for Tone "C";
- (88) Divider for Tone "D".

40 **Description:** The CPU (76) analyzes the data of each Transducer via the interface (82), composes and retains in memory the various messages to be transmitted but waits for Matrix AND (75) to indicate the transmission Block corresponding to the command received. In fact, dependent on this command the transmission can and shall take place:

- 45 1) Upon termination of the command if the unit has been addressed individually;
- 2) On the basis of the turn assigned to the unit as group sequence or universe sequence if the command has been addressed, respectively, to a specific group or to all the units connected to that Control.

In the instant in which the transmission shall start, the CPU actuates the Demultiplexer (78) to select the Tone to be used, as a function of the binary value of each pair of Bits of the Byte to be communicated, and enables the AND circuit (79) which will actuate the transmitter (80).

- ☐ The CPU is synchronized with the 50 Hz Line Sine waves by the circuit (77) through which it detects also the command code sent from the Control unit and sets up for the requested executions. In the event that an external device is addressed by the command, it will act through the Driver (83).

CLAIMS

1.- System for data transmission, remote sensing, remote controls, remote
5 readings and the like, particularly suitable for the electric power distribution lines,
characterized by the fact of being composed of one or more Control units (5), one or
more field Station units (9), the Control unit (Fig. 7) being composed essentially of
the following described sections, as shown:

Address Counters section

10 composed of electric circuits as described from no. (51) to no. (56);

Tone Reception section

composed of electric circuits as described from no. (57) to no. (63);

Logic section

composed of electric circuits as described from no.(64) to no. (65);

15 **Tone Transmission section**

composed of electric circuits as described from no. (66) to no. (67);

and the Station units (Fig. 8) for remote sensing, remote controls and the like, they
being composed essentially of the following described sections, as shown:

Address Counters section

20 composed of electric circuits as described from no. (71) to no. (75);

Logic section

composed of electric circuits as described from no. (76) to no. (83);

Oscillator section

composed of electric circuits as described from no. (84) to no. (88).

25 2.- System as per Claim no.1, characterized by the fact that to communicate the
system uses the special code composed of one or more Tones, consisting of
unmodulated frequencies, each of which transmitted for the duration of one Sine
wave of the power supply current and synchronously with it, assigning, to each of
the selected Tones, a different n Bits configuration so as to be able to communicate,
30 by successive steps, any binary configuration of one or more Bytes, as shown in
Figs.. 4 and 6.

3.- System as per Claim no. 2, characterized by the fact that to communicate
the system can also use Tones each of which transmitted for the duration of one
Half-wave of the power supply current.

35 4.- System as per Claims nos. 2 and 3, characterized by the fact that to
communicate the system can also use the absence of Tone as significant; to this
absence may be assigned one of the possible n Bit binary values.

5. - System as per Claims nos. 2, ²⁰3 and 4, characterized by the fact that to communicate the system can also use one or more Tones each of which transmitted for the duration of multiples of the power supply current Sine waves, as shown in Fig. 5.
- 5 6. - System as per Claims nos. 2, 3, 4 and 5, characterized by the fact that to communicate the system can also use Tones each of which transmitted for the duration of a fraction of the power supply current Half-wave.
7. - System as per Claims nos. 2, 3, 4, 5 and 6, characterized by the fact that the synchronous communication protocol is able to eliminate all the separation pauses
10 between the various logic blocks, as shown in Figs. 4, 5 and 6.
8. - System as per Claims nos. 2, 3, 4, 5, 6 and 7, characterized by the fact that all the units of the system can communicate between themselves without interfering among different groups, using Tones synchronized with the frequency of the same electric power supply line.
- 15 9. - System as per Claim no. 8, characterized by the fact that all the units composing the system communicate between themselves via the same electric power supply line also in "Full Duplex" bidirectional mode.
10. - System as per Claim no. 1, characterized by the fact that to feed the Stations connected to the public lighting network in the hours when such lighting is
20 off, the System inserts into the electric power supply line a low voltage subsidiary feed which ensures the operation of the Stations without causing the illumination of the lamps.
11. - System as per one or more of the above Claims, characterized by the fact that the system can also use, as transmission media, lines dedicated only to the
25 transmission of data and commands.
12. - System for data transmission, remote sensing, remote control, remote reading and the like, conceptually as described and illustrated with reference to the text and to the figures of the enclosed drawings or as per one or more of the above Claims, as well as any portion thereof, whether separate, combined, reduced or
30 expanded or reproduced with components other than those shown in the examples.

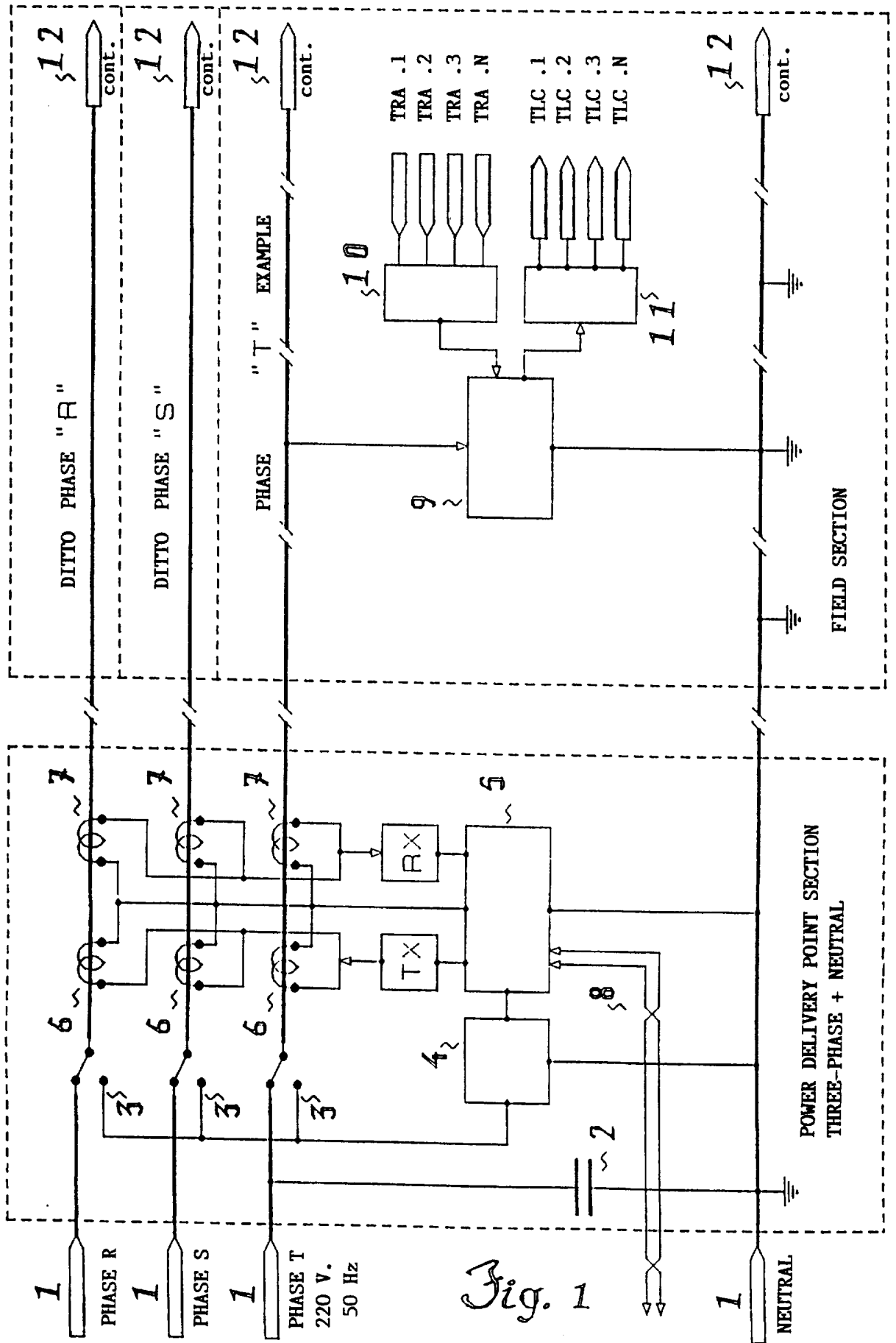

Fig. 1

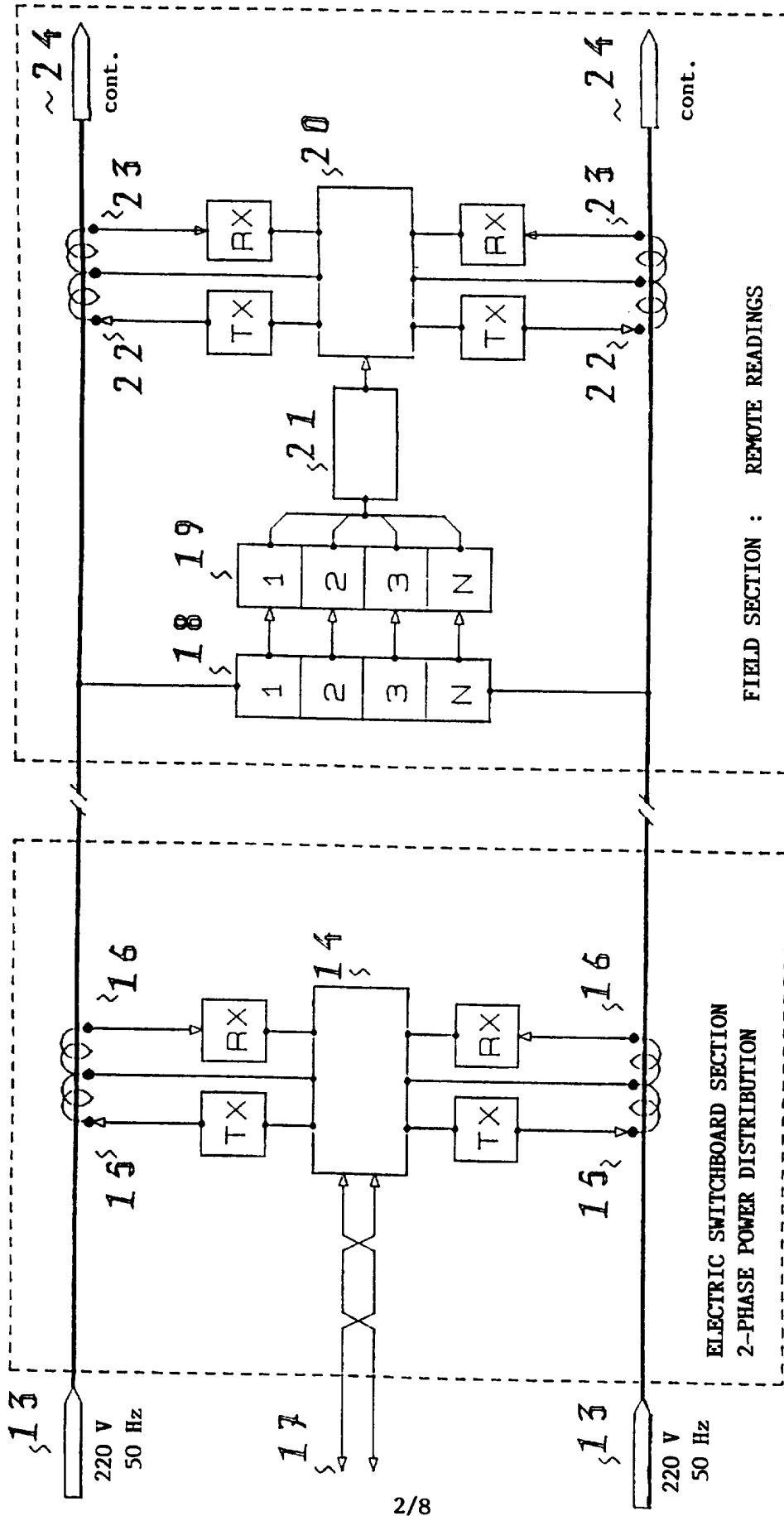

Fig. 2

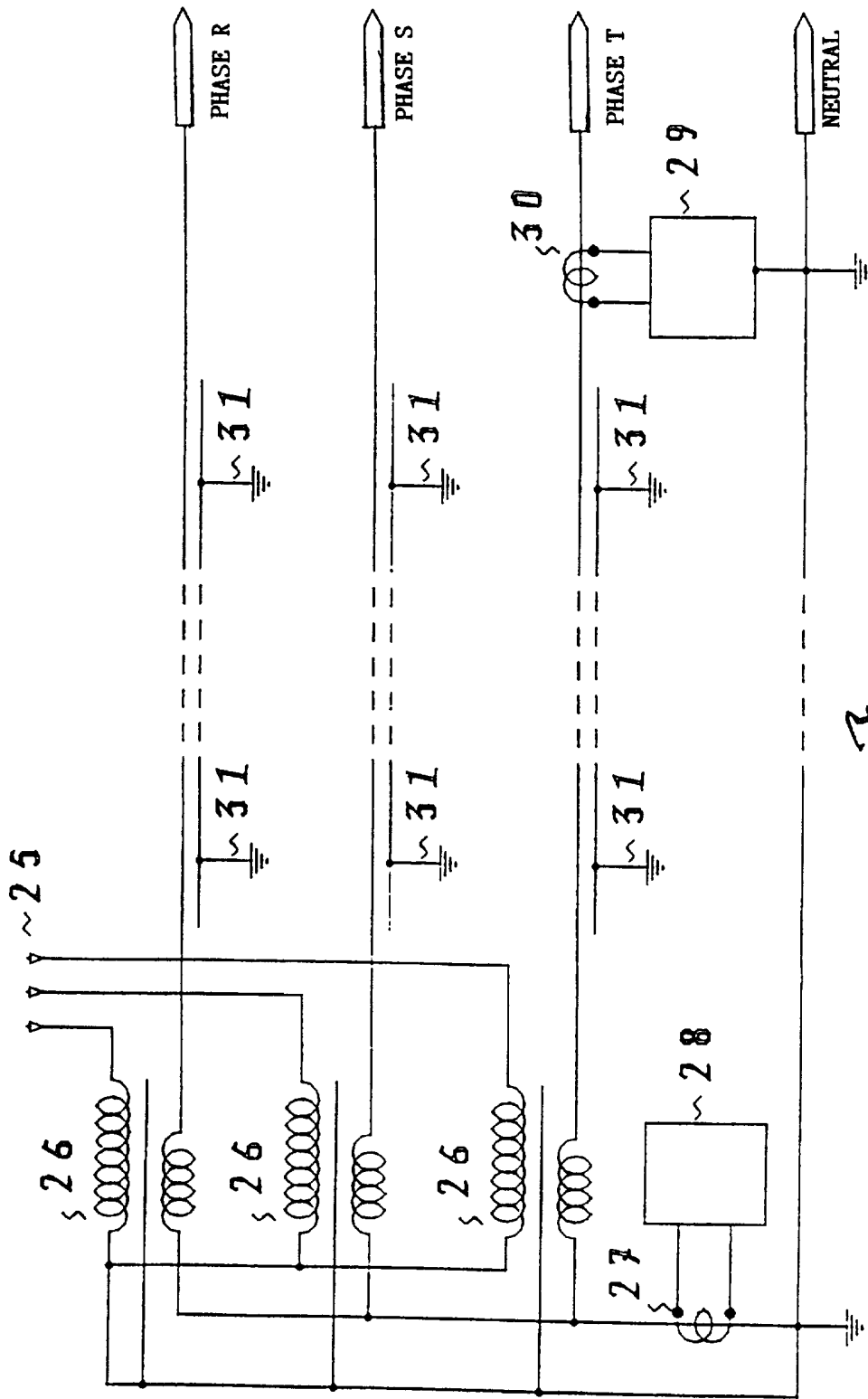

Fig. 3

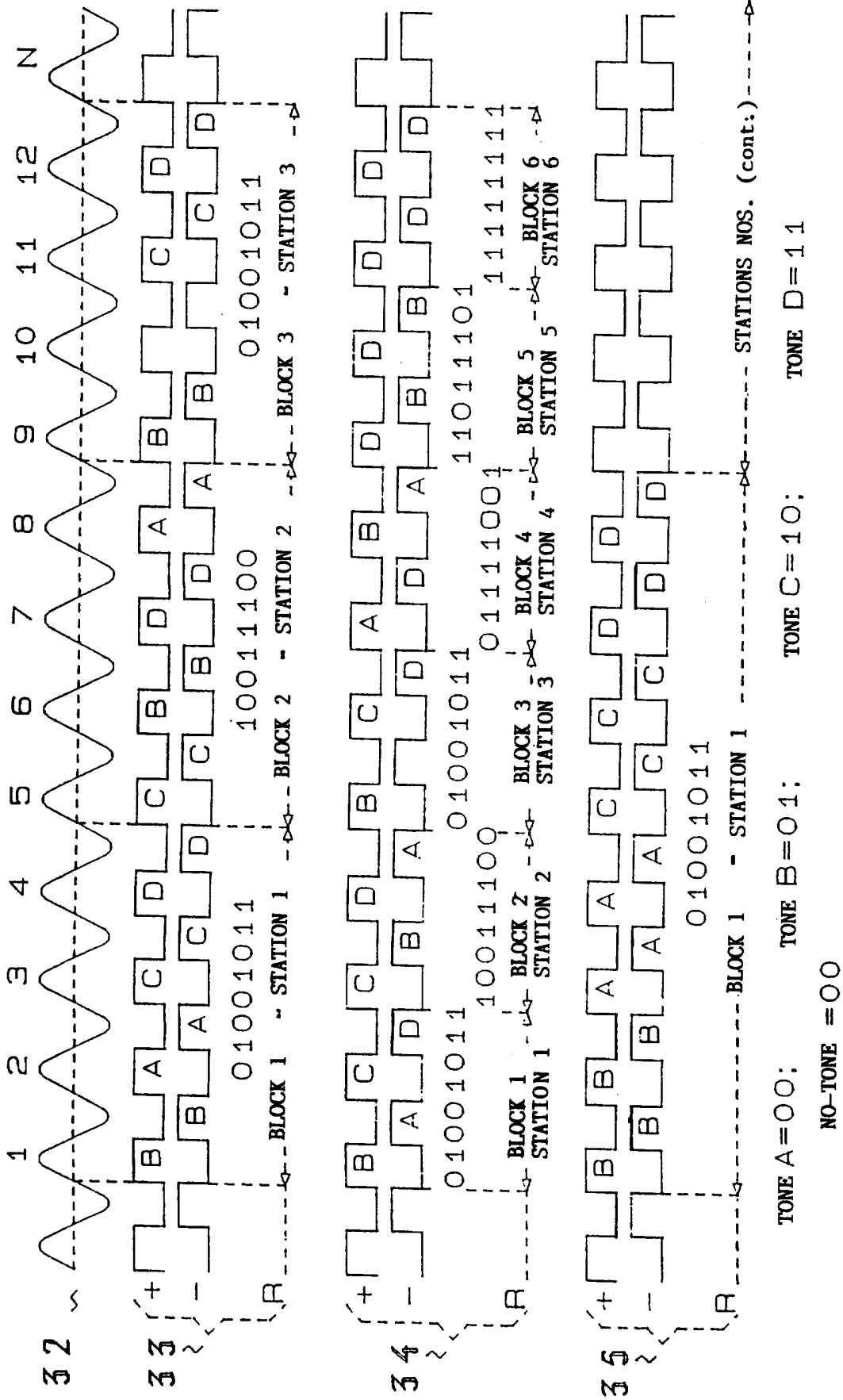
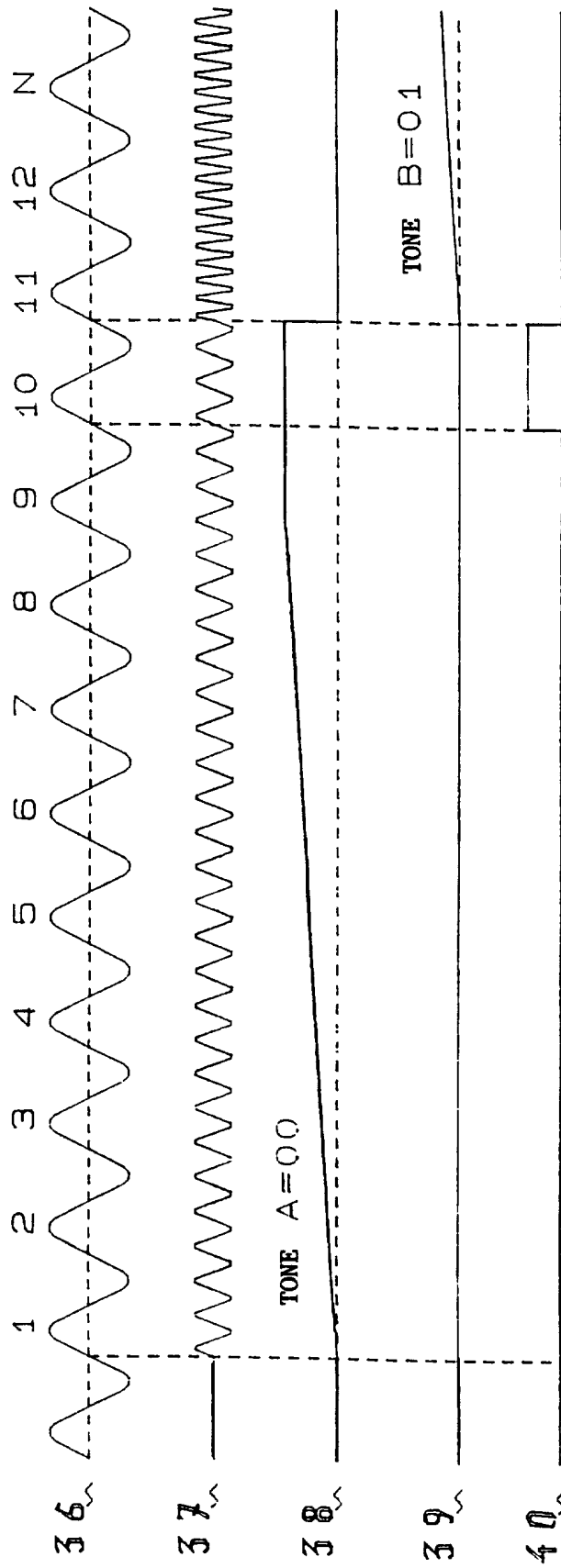

Fig. 4



TONE A=00; TONE B=01; TONE C=10; TONE D=11;

Fig. 5

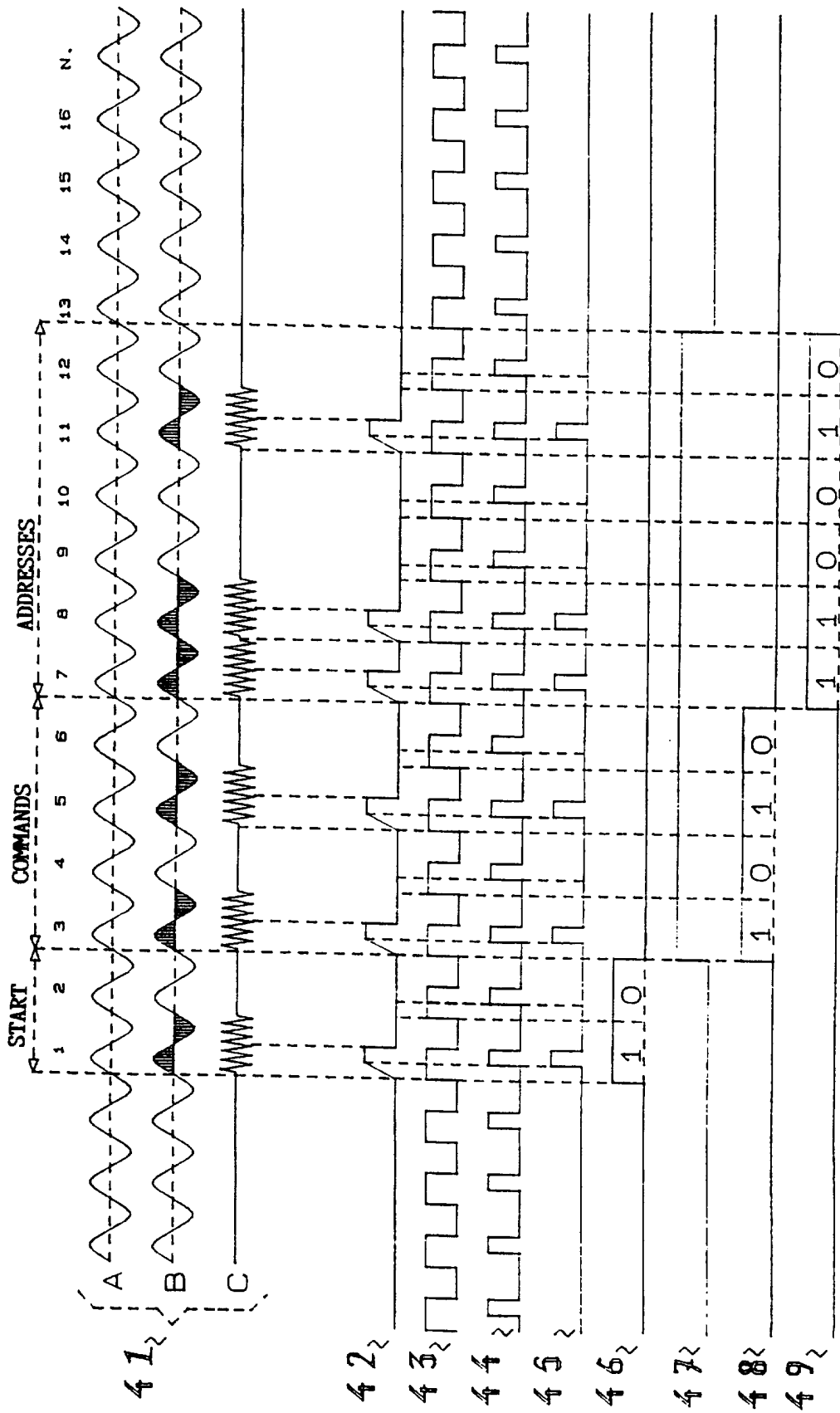

Fig. 6

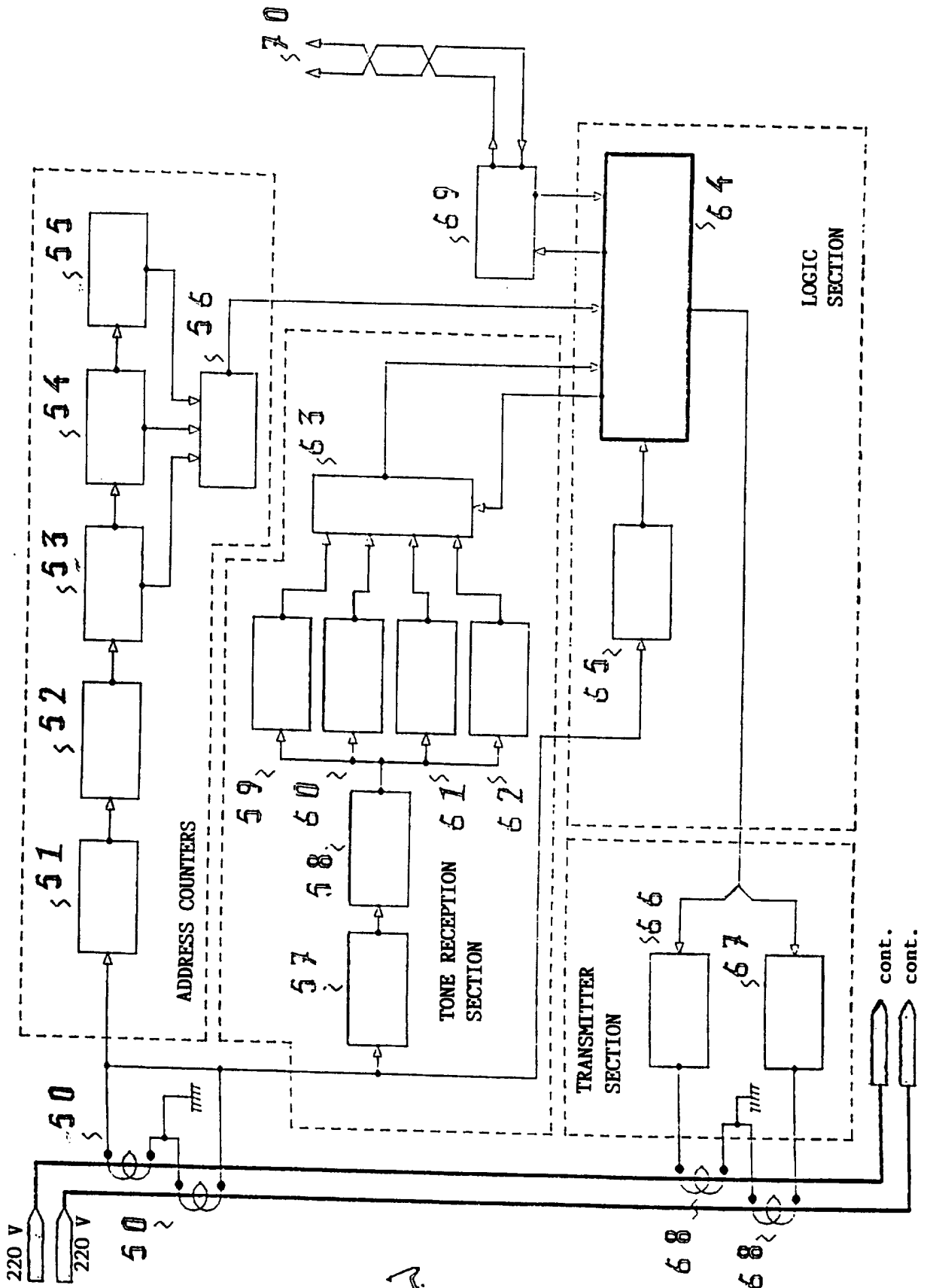

Fig. 7

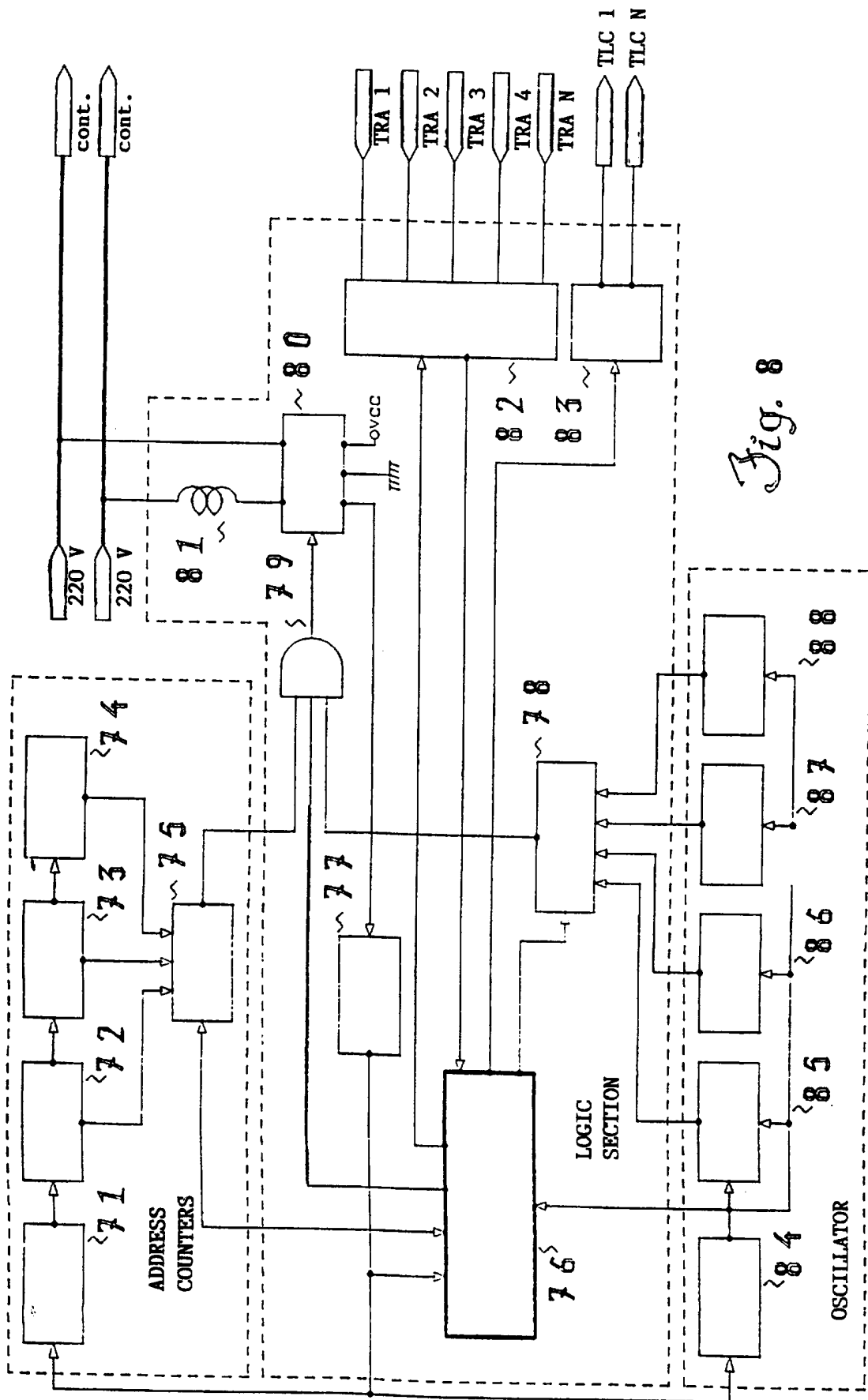

Fig. 8

INTERNATIONAL SEARCH REPORT

Intern. Patent Application No. PCT/IT 97/00033

A. CLASSIFICATION OF SUBJECT MATTER
 H 04 B 3/54

According to International Patent Classification (IPC) or to both national classification and IPC⁶

B. FIELDS SEARCHED

Minimum documentation searched (classification system followed by classification symbols)
 H 04 B

Documentation searched other than minimum documentation to the extent that such documents are included in the fields searched

Electronic data base consulted during the international search (name of data base and, where practical, search terms used)

C. DOCUMENTS CONSIDERED TO BE RELEVANT

Category*	Citation of document, with indication, where appropriate, of the relevant passages	Relevant to claim No.
A	US, A, 4 429 299 (KABAT) 31 January 1984 (31.01.84), fig. 4; abstract. --	1
A	US, A, 4 430 639 (BENNETT) 07 February 1984 (07.02.84), fig. 4,5; abstract. --	1
A	EP, A, 0 445 375 (KRONE) 11 September 1991 (11.09.91), fig. 1; abstract. ----	1

Further documents are listed in the continuation of box C. Patent family members are listed in annex.

* Special categories of cited documents :

<p>"A" document defining the general state of the art which is not considered to be of particular relevance</p> <p>"E" earlier document but published on or after the international filing date</p> <p>"L" document which may throw doubts on priority claim(s) or which is cited to establish the publication date of another citation or other special reason (as specified)</p> <p>"O" document referring to an oral disclosure, use, exhibition or other means</p> <p>"P" document published prior to the international filing date but later than the priority date claimed</p>	<p>"T" later document published after the international filing date or priority date and not in conflict with the application but cited to understand the principle or theory underlying the invention</p> <p>"X" document of particular relevance; the claimed invention cannot be considered novel or cannot be considered to involve an inventive step when the document is taken alone</p> <p>"Y" document of particular relevance; the claimed invention cannot be considered to involve an inventive step when the document is combined with one or more other such documents, such combination being obvious to a person skilled in the art.</p> <p>"&" document member of the same patent family</p>
--	--

Date of the actual completion of the international search 16 May 1997	Date of mailing of the international search report 18.06.97
--	--

Name and mailing address of the ISA European Patent Office, P.B. 5818 Patentlaan 2 NL - 2280 HV Rijswijk Tel. (+ 31-70) 340-2040, Tx. 31 651 epo nl, Fax: (+ 31-70) 340-3016	Authorized officer DRÖSCHER e.h.
--	-------------------------------------

ANHANG

zum internationalen Recherchenbericht über die internationale Patentanmeldung Nr.

ANNEX

to the International Search Report to the International Patent Application No.

ANNEXE

au rapport de recherche international relatif à la demande de brevet international n°

PCT/IT 97/00033 SAE 153399

In diesem Anhang sind die Mitglieder der Patentfamilien der im obengenannten internationalen Recherchenbericht angeführten Patentdokumente angegeben. Diese Angaben dienen nur zur Unterrichtung und erfolgen ohne Gewähr.

This Annex lists the patent family members relating to the patent documents cited in the above-mentioned international search report. The Office is in no way liable for these particulars which are given merely for the purpose of information.

La présente annexe indique les membres de la famille de brevets relatifs aux documents de brevets cités dans le rapport de recherche international visée ci-dessus. Les renseignements fournis sont donnés à titre indicatif et n'engagent pas la responsabilité de l'Office.

Im Recherchenbericht angeführtes Patentdokument Patent document cited in search report Document de brevet cité dans le rapport de recherche	Datum der Veröffentlichung Publication date Date de publication	Mitglied(er) der Patentfamilie Patent family member(s) Membre(s) de la famille de brevets	Datum der Veröffentlichung Publication date Date de publication
US A 4429299	31-01-84	CA A1 1151261 GB A1 2039402 GB B2 2039402	02-08-83 06-08-80 11-05-83
US A 4430639	07-02-84	keine - none - rien	
EP A1 445375	11-09-91	AU A1 70049/91 CA AA 2037557 DE A1 4008023 DE C2 4008023 FI A0 911169 FI A 911169 JP A2 4220023 NO A0 905446 NO A 905446	12-09-91 10-09-91 12-09-91 12-03-92 08-03-91 10-09-91 11-08-92 18-12-90 10-09-91