

(19)



Europäisches Patentamt
European Patent Office
Office européen des brevets



(11)

EP 0 818 280 A3

(12)

EUROPEAN PATENT APPLICATION

(88) Date of publication A3:
13.05.1998 Bulletin 1998/20

(51) Int Cl.6: B25C 1/08

(43) Date of publication A2:
14.01.1998 Bulletin 1998/03

(21) Application number: 97305041.2

(22) Date of filing: 09.07.1997

(84) Designated Contracting States:
AT BE CH DE DK ES FI FR GB GR IE IT LI LU MC
NL PT SE

- Bolger, Richard P.
Schaumburg, Illinois (US)
- Dewey, George G.
Palatine, Illinois (US)
- Wendling, E. Jonathan
Algonquin, Illinois (US)

(30) Priority: 12.07.1996 US 679526
05.06.1997 US 869984

(71) Applicant: ILLINOIS TOOL WORKS INC.
Glenview, Illinois 60025 (US)

(74) Representative: Rackham, Stephen Neil
GILL JENNINGS & EVERY,
Broadgate House,
7 Eldon Street
London EC2M 7LH (GB)

(72) Inventors:
• Velan, Michael
Mt. Prospect, Illinois (US)

(54) Powered fastener driving tool

(57) A fastener detection system (70) is provided for both internal combustion and powder actuated fastener driving tools (10). A sensor (54) disposed at a portion of a fastener supply path (38) detects the presence or absence of a fastener (46). An indicator (60) notifies an operator when the sensor (54,55) detects the absence of a fastener. In the combustion tool (10), either or both of fuel delivery and combustion ignition may alternatively or also be disabled when no fastener (46) is detected.

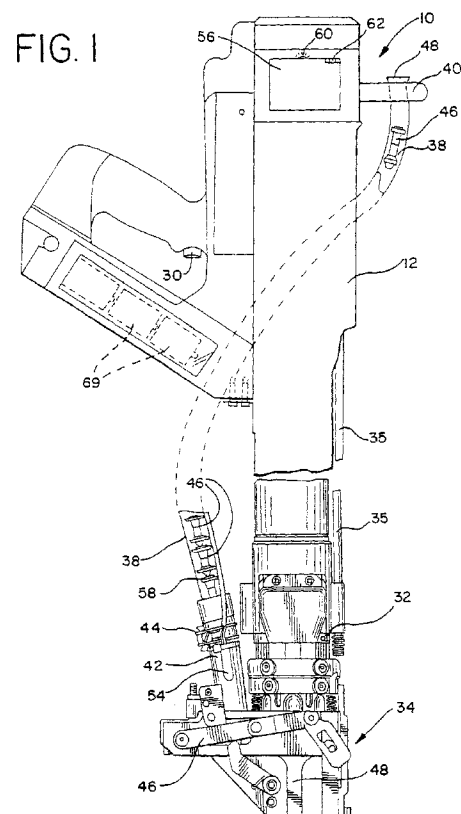

EP 0 818 280 A3



European Patent
Office

EUROPEAN SEARCH REPORT

Application Number
EP 97 30 5041

DOCUMENTS CONSIDERED TO BE RELEVANT				
Category	Citation of document with indication, where appropriate, of relevant passages	Relevant to claim	CLASSIFICATION OF THE APPLICATION (Int.Cl.6)	
X	US 4 978 045 A (MURAKAMI) * column 5, line 17-26 * * column 6, line 29-32 * * column 6, line 56-58 * * column 7, line 8-11; figure 1 *	1,8	B25C1/08	
Y	---	2-4		
X	US 4 386 725 A (CHAMBERS) * column 4, line 29-53; figures 2,3 *	1,7,8		
Y	EP 0 544 471 A (ILLINOIS TOOL WORKS) * abstract *	2-4		
A	US 4 715 522 A (JORDAN) * the whole document *	1,3,9		
A	US 3 961 408 A (GOODSMITH) * column 3, line 4-16 *	1,3		
A	EP 0 711 634 A (ILLINOIS TOOL WORKS) * column 5, line 38 - column 6, line 22 *	7		
A	US 5 181 315 A (GOODSMITH) * column 7, line 45-62 *	1		TECHNICAL FIELDS SEARCHED (Int.Cl.6)
A	EP 0 056 989 A (SIGNODE) * figure 2 *	2-5		B25C B23P
The present search report has been drawn up for all claims				
Place of search THE HAGUE		Date of completion of the search 24 March 1998	Examiner Matzdorf, U	
CATEGORY OF CITED DOCUMENTS		T : theory or principle underlying the invention E : earlier patent document, but published on, or after the filing date D : document cited in the application L : document cited for other reasons & : member of the same patent family, corresponding document		
X : particularly relevant if taken alone Y : particularly relevant if combined with another document of the same category A : technological background O : non-written disclosure P : intermediate document				

EPO FORM 1503 03 82 (P04C01)