



US 20070175111A1

(19) **United States**

(12) **Patent Application Publication**  
**Zhong**

(10) **Pub. No.: US 2007/0175111 A1**

(43) **Pub. Date: Aug. 2, 2007**

(54) **OVERLAP ONE PAIR OF SEMICIRCLES FOR THE FOLDING TYPHOON DEFENSE COMBINING STRUCTURE**

(52) **U.S. Cl. .... 52/167.1**

(75) **Inventor: Ci-Jing Zhong, Taipei (TW)**

(57) **ABSTRACT**

Correspondence Address:  
**Ci-Jing ZHONG**  
**P.O. Box 44 - 2049**  
**Taipei 10668 (TW)**

The invention related to an overlap one pair of semicircles for the folding typhoon defense combining structure, and it has installed several pieces of defend typhoon structure body between the left frame and the right frame of the window, its characteristic lies in: Defend structure body and include several even rounds-lack overlaps post, several even round-lack head defend typhoon board and two upright posts to make up, and the terminal surface of left frame and right frame have round-lack seat in order to join even round-lack head defend typhoon board, so, an overlap one pair of semicircles for the folding typhoon defense combining structure of the present invention is between the left frame and right frame, can form a result of effective dyke.

(73) **Assignee: CHIU JOU ALUMINIUM CO., LTD.**

(21) **Appl. No.: 11/332,346**

(22) **Filed: Jan. 17, 2006**

**Publication Classification**

(51) **Int. Cl.**  
**E04H 9/02 (2006.01)**

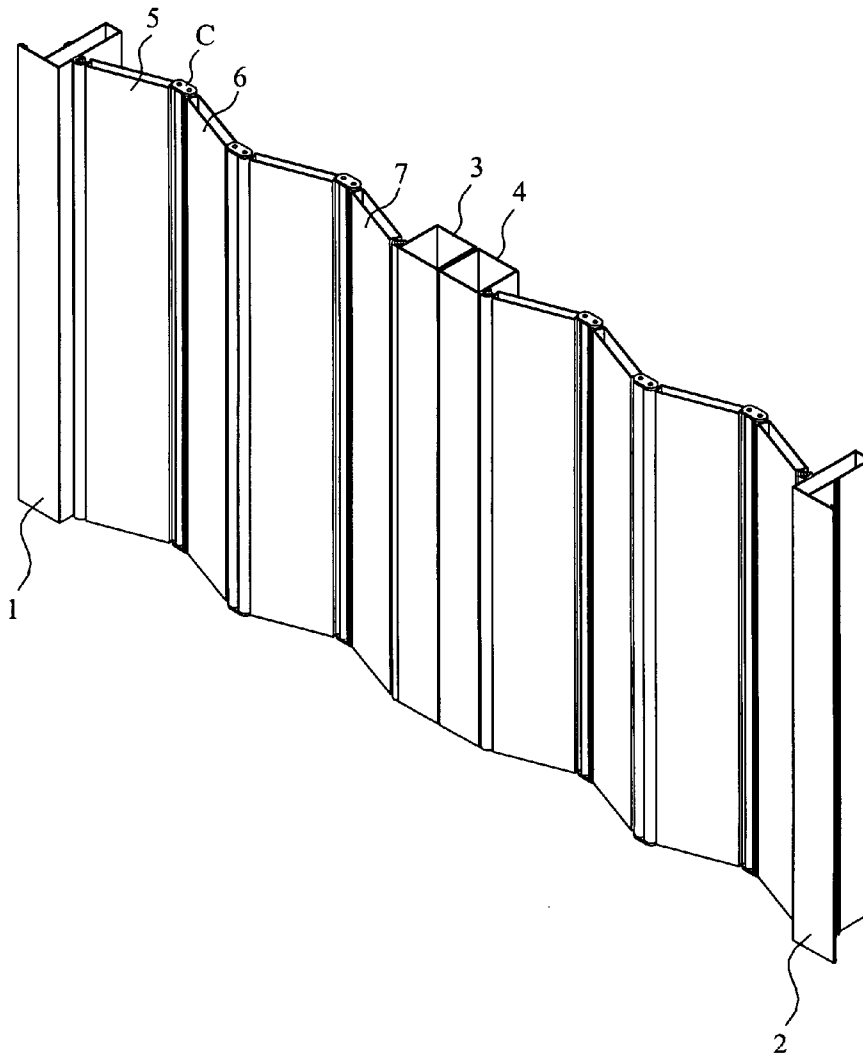

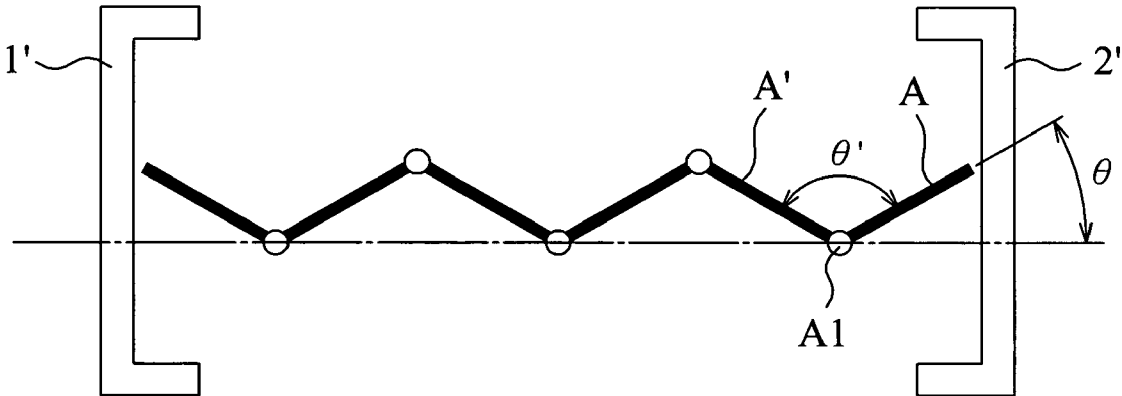

FIG. 1  
(PRIOR ART)

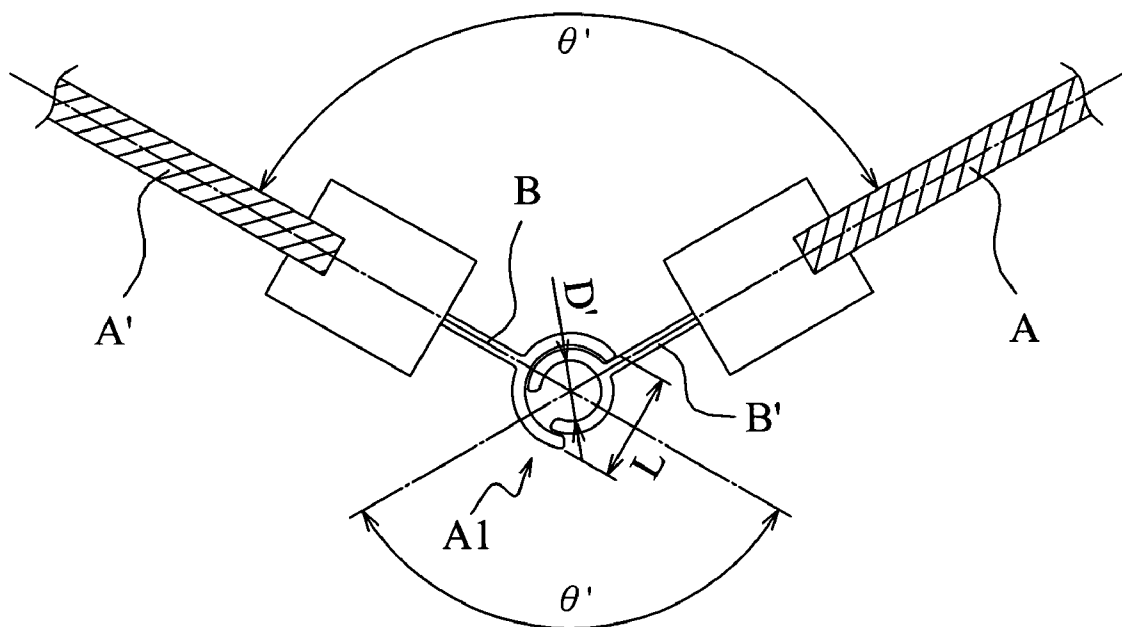

FIG. 2  
(PRIOR ART)

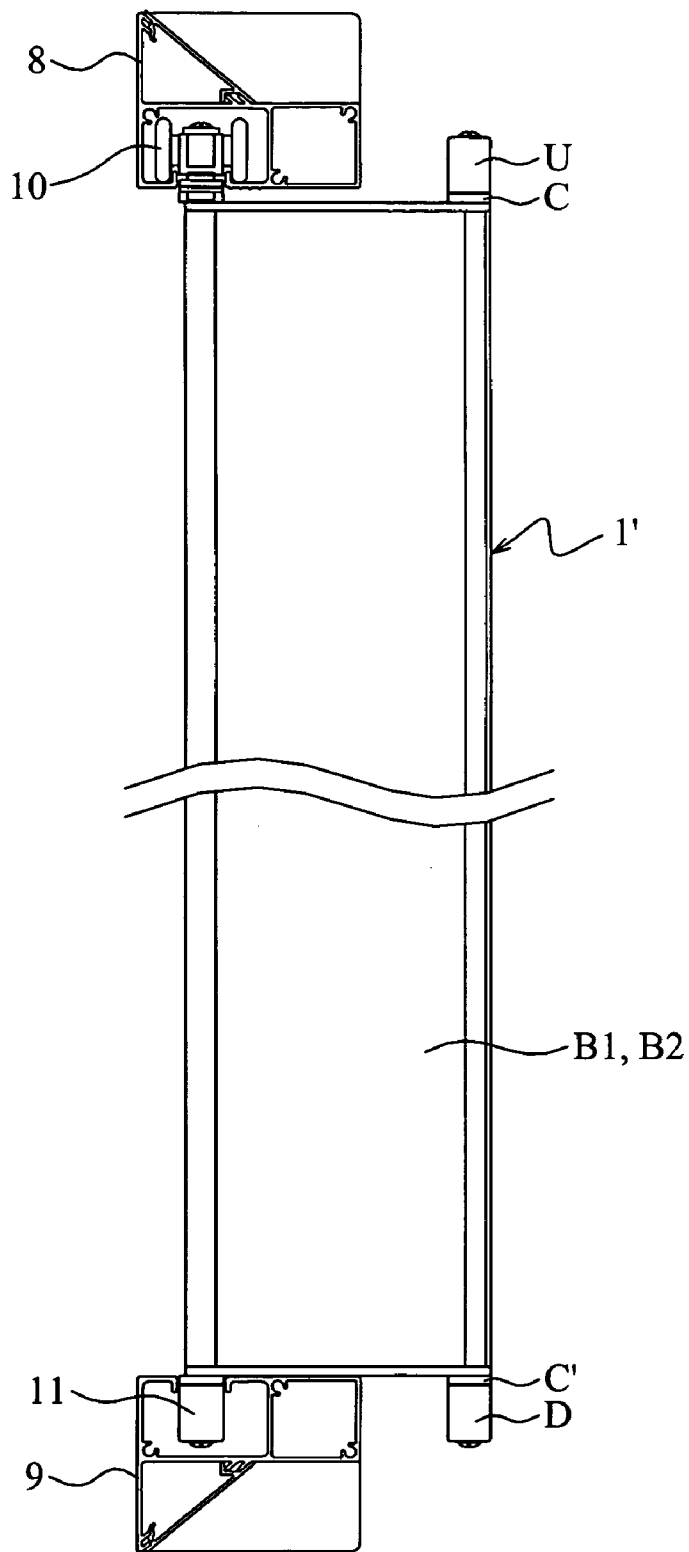

FIG. 3

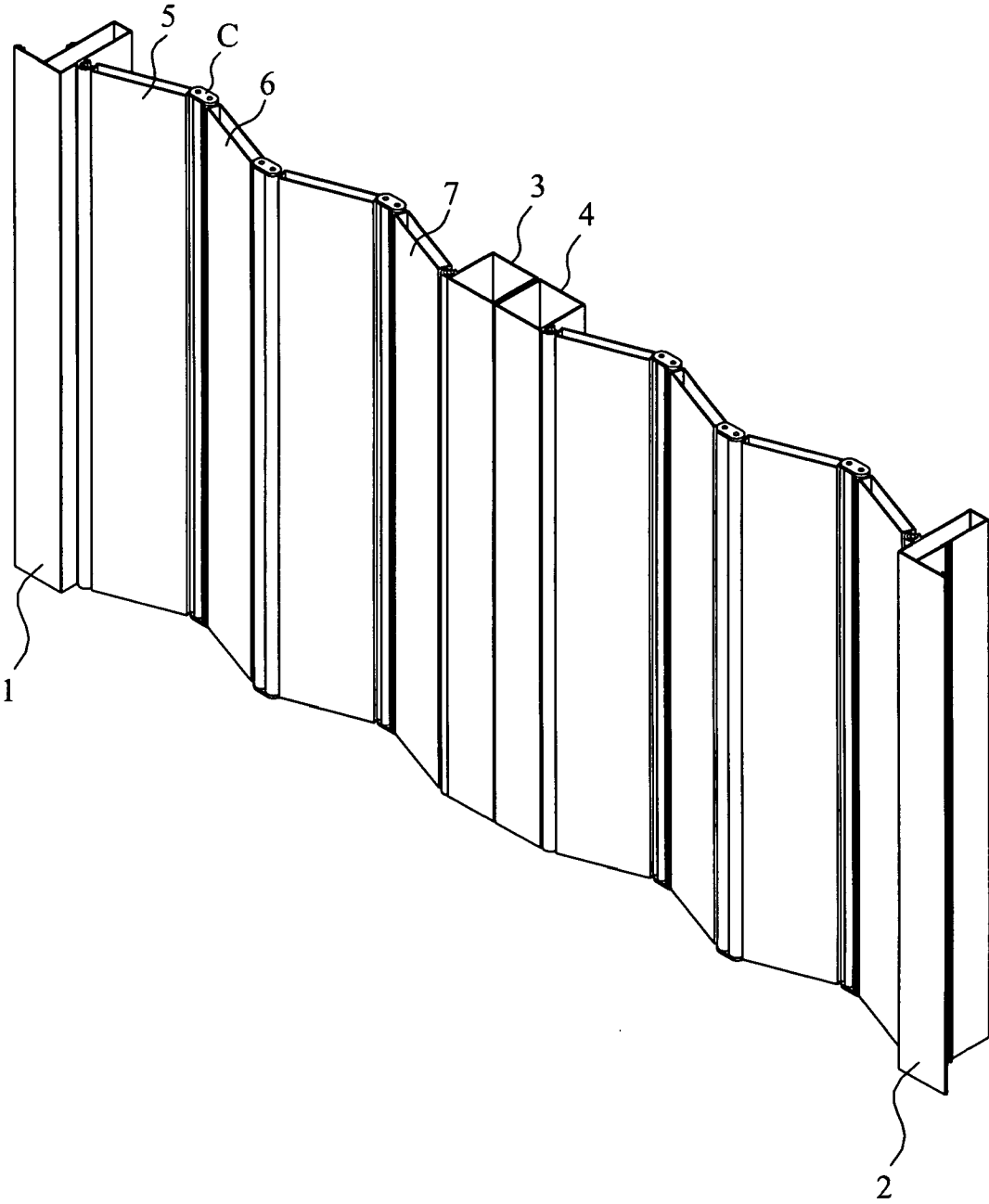

FIG. 4

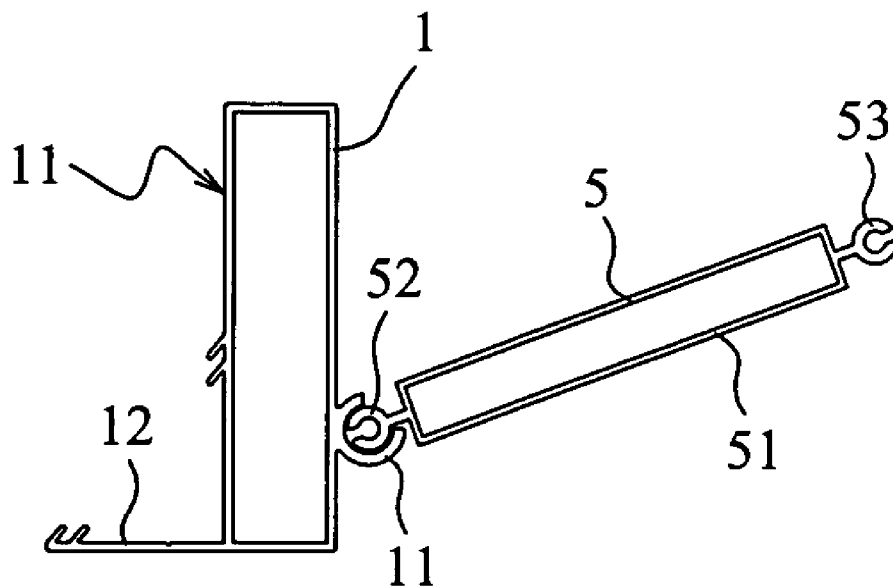

FIG. 5

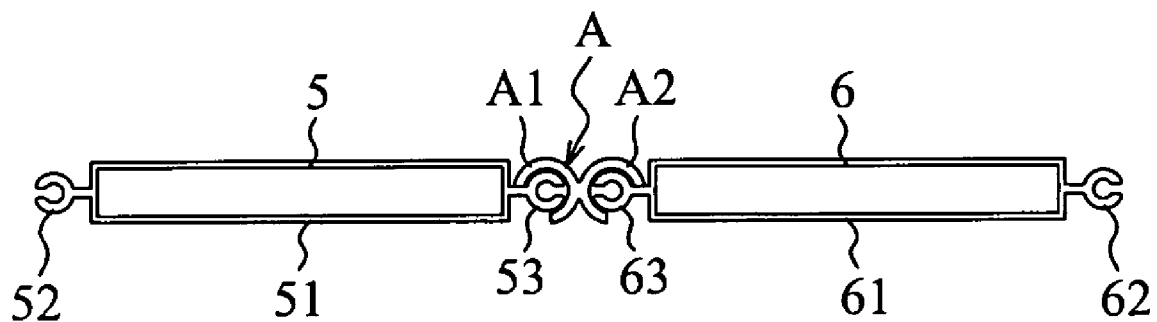

FIG. 6

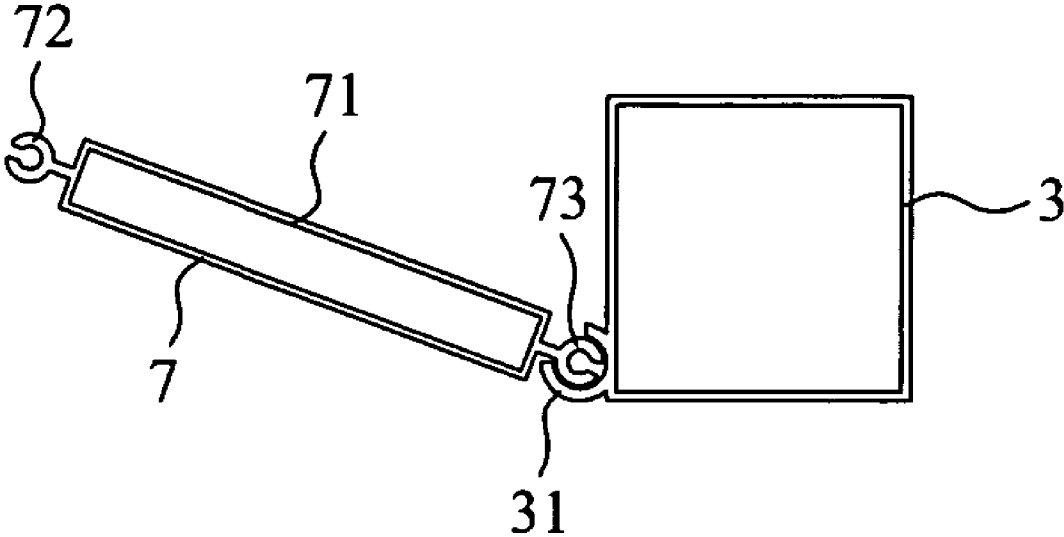

FIG. 7

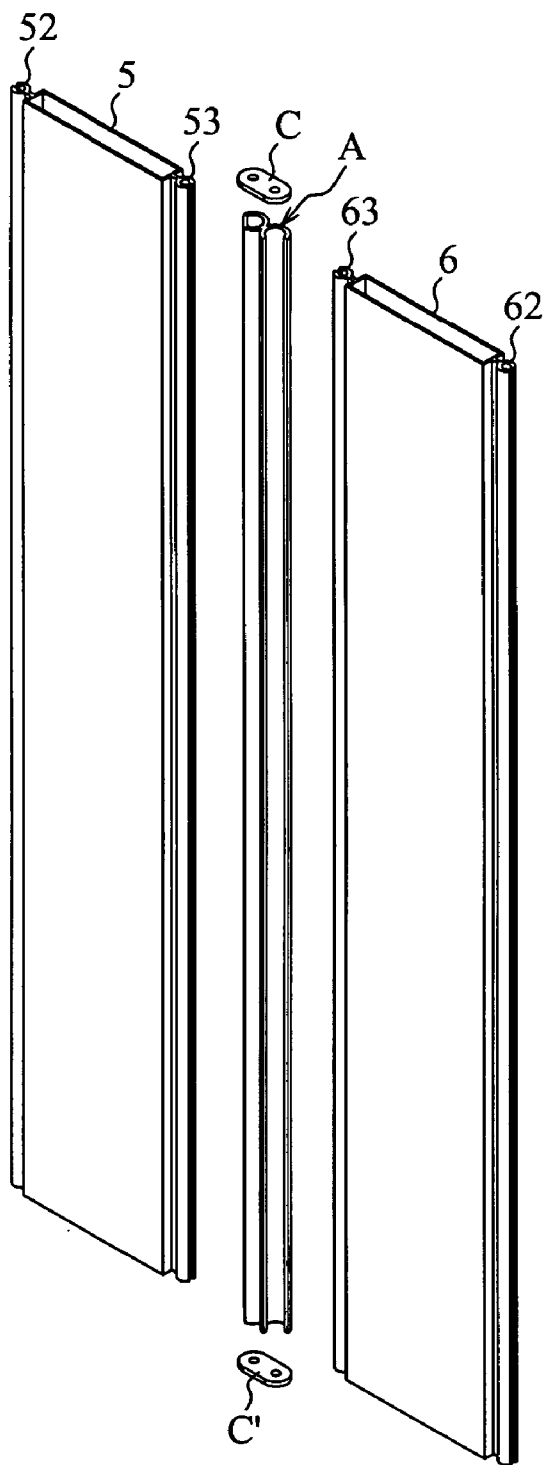

FIG. 8

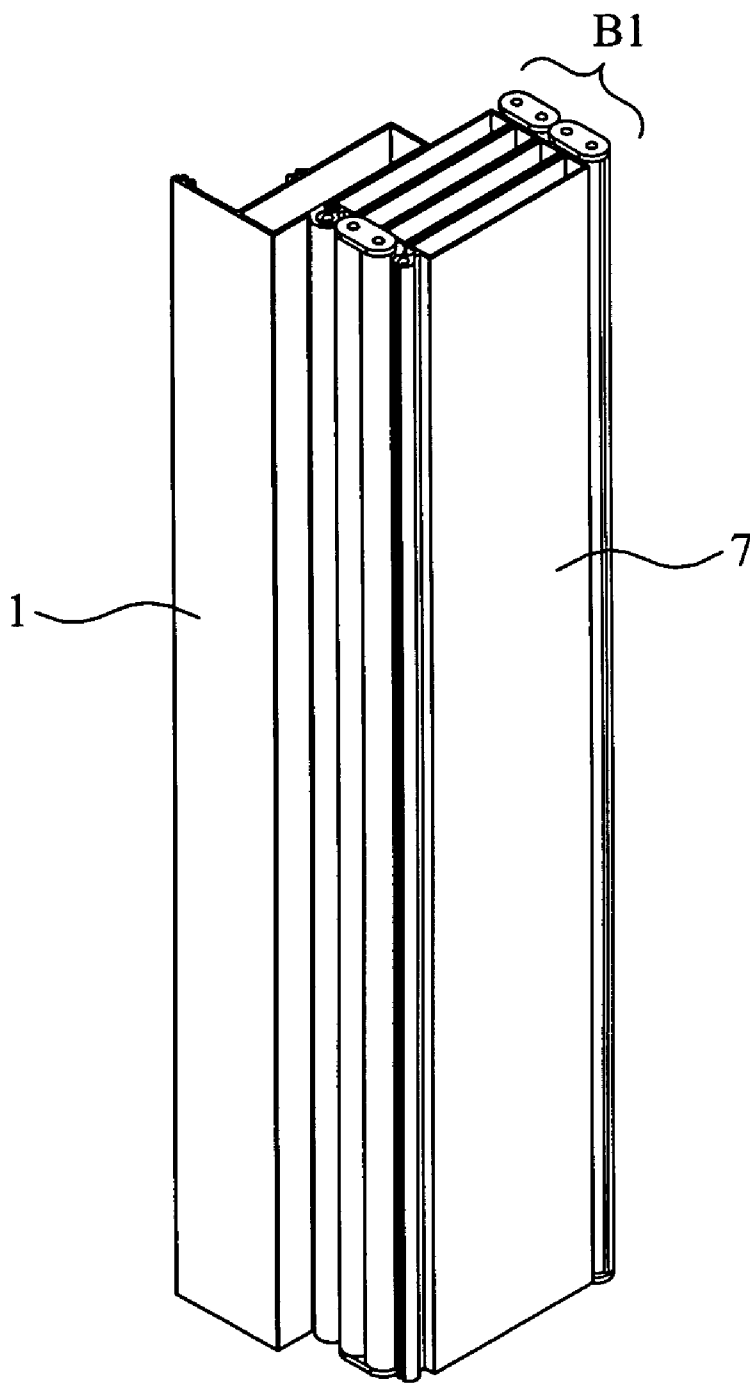

FIG. 9

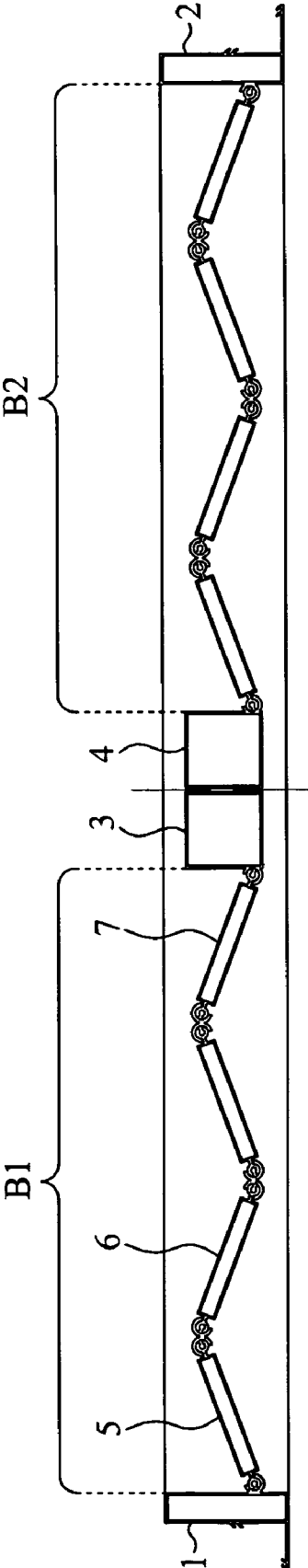

FIG.10

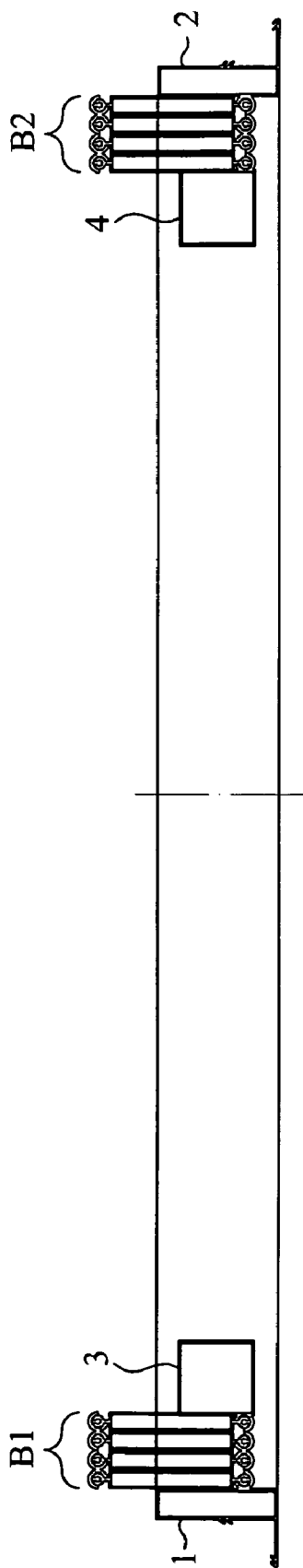

FIG.11

**OVERLAP ONE PAIR OF SEMICIRCLES FOR THE FOLDING TYPHOON DEFENSE COMBINING STRUCTURE**

**BACKGROUND OF THE INVENTION**

[0001] 1. Field of the Invention

[0002] The present invention related to an overlap one pair of semicircles for the folding typhoon defense combining structure, mean particularly that installs the body of a structure of several pieces of typhoon defense between the left frame and right frame, and can be produced open the state and close the state, and form the whole window frame and have platform-proof function.

[0003] 2. Description of the Prior Arts

[0004] The general platform-proof structure of window frame, have it in regular way between window frames, load onto several blocks of typhoon defense and a blade of crosswise between the left frame and right frame, it is regular and unable to achieve the goal of totally opening that it lacks the department and defends a blade, another regard two shackles as a typhoon defense board of combined and combine with the upright post, it is not firm that their lacks combination combining the shackle of the department, loaded as a defend typhoon board onto the left frame and prone to the loose phenomenon of taking off between the right frame, and it is too small to open the angle, there should be width to could reach with more blades, the manufacturing cost is too high, it is too big to open the angle, the place combined, it is apt to come off.

[0005] Another, referring to as show in FIG. 1, among the window frame between left frame 1" and right frame 2' have install by arranging for defend typhoon window of several pieces, among them defend typhoon window body connect with defend typhoon window body a' and produced a connected point a1; The two hook loops b, b' hooks and joints with defend typhoon window body a, a', among the defend typhoon window body can be form a angle of  $\theta'$ , and defend typhoon window body a and parallel and form a  $\theta$  angle. As the opening a angle of the " $\theta$ " the angle between defend typhoon window body a and defend typhoon window body a' forms like FIG. 2 at the time of the combination shown, among them hook loop b' internal diameter the long is D', and whether hook loop b open because mouthfuls of length L, so in act as  $L \geq D'$  when the defend typhoon window body a, a' are not open until angle of  $180^\circ$ , and make defend typhoon window body a and defend typhoon window body a produce phenomenon of coming off, act as  $D' > L$  defend typhoon window body a, a' opening is limited.

**SUMMARY OF THE INVENTION**

[0006] An object of present invention is to provide an overlap one pair of semicircles for the folding typhoon defense combining structure, install several pieces of defend typhoon structure body combined with upright post at least between left frame and right frame mainly, and mutually combine and stabilize with the left frame and right frame, among them defend typhoon structure body and include several rounds and even round-lack overlap post and several even round-lack heads and arc-round bottom seats to make up, and even round-lack overlap post have two round-lack terminal surfaces and even round-lack head defend typhoon

board mutual joint and stabilize, and even round-lack overlap post install the both ends of a even round-lack defend typhoon board by arranging mutually and symmetrically, so, an overlap one pair of semicircles for the folding typhoon defense combining structure install a joining mass pulley in the terminal surface of the above and below, make the product of present invention can open of the state and close of the state, to break through traditional type hook loops combine the structure, in order to get the result of defending the platform.

**BRIEF DESCRIPTION OF THE DRAWINGS**

[0007] The other objects and features of the present invention can be more fully understood by referring to the following description of preferred embodiments and accompanying drawing, in which:

[0008] FIG. 1 is an above view of defend typhoon window of the prior art.

[0009] FIG. 2 is a view of a junction point of defend typhoon window of the prior art.

[0010] FIG. 3 is a cross-section view of an overlap one pair of semicircles for the folding typhoon defense combining structure body combined with the above frame and below frame of the present invention.

[0011] FIG. 4 is a three-dimensional view of the defend typhoon structure body combined with upright post, left frame and right frame of the present invention.

[0012] FIG. 5 is a view of even round-lack head defend typhoon board combined with left frame of the present invention.

[0013] FIG. 6 is a view of even round-lack head defend typhoon board combined with even round-lack overlap post for opening the state of the present invention.

[0014] FIG. 7 is a view of even round-lack head defend typhoon board combined with upright post of the present invention.

[0015] FIG. 8 is a decomposition three-dimensional view of an even round-lack head defend typhoon board, even round-lack overlap post and arc-round bottom seat of the present invention.

[0016] FIG. 9 is a three-dimensional view of defend typhoon structure body combined with left frame for opening the state of the present invention.

[0017] FIG. 10 is a top view of an overlap one pair of semicircles for the folding typhoon defense combining structure for closing the state of the present invention.

[0018] FIG. 11 is a top view of an overlap one pair of semicircles for the folding typhoon defense combining structure for opening the state of the present invention.

**DETAILED DESCRIPTION OF THE PREFERRED EMBODIMENT**

[0019] This invention related to an overlap one pair of semicircles for the folding typhoon defense combining structure, among an overlap one pair of semicircles for the folding typhoon defense combining structure consists of the left frame, defend typhoon structure body B1, B2, two upright posts 3,4 and right frame as show in FIG. 8, among

left frame 1 is long square terminal surface 11' at the above and install a enhancement board 12 of the left at the below, and install a round-lack seat 11 on the terminal surface of right section combined with the round-lack connected head 52 of an even round-lack head defend typhoon board 5, and the right frame 2 is also the same as FIG. 5 shows above-mentioned.

[0020] Referring to FIG. 6, FIG. 8, and FIG. 10, it has several rotate to opening and closing of defend typhoon structure body B1,B2 between the left frame 1 and right frame 2 with proper distance mainly, and among a defend typhoon structure body B1,B2 including several even round-lack overlap posts A, several even round-lack head defend typhoon boards 5,6 and several arc-round bottom C,C', among an even round-lack overlap rounds lacks and overlaps post A: two round-lack terminal surface plate A1,A2 of the integrative shaping, and as show in FIG. 6 and FIG. 7, even round-lack head defend typhoon board 5 and even round-lack head defend typhoon board 6 have long square body 51,56 in the middle, and even round-lack head defend typhoon board 5 have installed two round-lack connected heads 52,53 on the terminal surfaces, and even round-lack head defend typhoon board 6 have installed two round-lack connected heads 62,63 on the terminal surfaces, and round-lack connected heads 53, 63 insert to round-lack terminal surfaces A1, A2, and on two terminal surface put arc-round bottom seats C,C' as show in FIG. 8, and FIG. 6 shows that two even round-lack head defend typhoon board 5,6 joint with an even round-lack overlap post, which can open and reach the horizontal state.

[0021] Referring to FIG. 4 and FIG. 7, the upright post 3 install round-lack seat 31, and combined with an even round-lack head defend typhoon board 7: Central authorities long square body 71, even round-lack head defend typhoon board 7 is installed by round-lack connected head 72, 73 in the terminal surface and the mutual connection, and it is installed by a round-lack seat combined with even round-lack head defend typhoon board in the upright post 4 of the below right.

[0022] Referring to FIG. 3, FIG. 9, FIG. 10 and FIG. 11, wherein FIG. 9 for a defend typhoon of structure body B1 and left frame 1 a part of open state for the mutual combination, and the wholly of defend typhoon structure bodies B1,B2 combined with upright posts 3,4, and the result is opening state between left frame 1 and right frame 2 as show in FIG. 11, and an overlap one pair of semicircles for the folding typhoon defense combining structure body 1' of the combination state between the above frame 8 and the below frame 9 for the window, among a defend typhoon of structure body B1,B2 for outside of the terminal surface, which it has installed connected mass U,D at the below or top, and it install pulley 10 in the above frame 8 and connected mass 11 at the below.

[0023] We know the characteristic with the following of the present invention according to above-mentioned bases:

[0024] 1. The present of an overlap one pair of semicircles for the folding typhoon defense combining structure to

adopt special-designed for an even round-lack overlap post as the two-way combination to even round-lack head defend typhoon board, and can extend limitlessly between the left frame and the right frame of window frame.

[0025] 2. The present of an overlap one pair of semicircles for the folding typhoon defense combining structure, adopt even round-lack head defend typhoon board combined with even round-lack overlap post, it combines and stabilizes and break through one pair of shackles of traditional type to combine unstability.

[0026] 3. The present of an overlap one pair of semicircles for the folding typhoon defense combining structure, and an even round-lack overlap post install in both ends of an even round-lack head defend typhoon board to form the arrangement mutually and symmetrically.

What is claimed is:

1. An overlap one pair of semicircles for the folding typhoon defense combining structure composed of the left frame, several defend typhoon structure bodies, two upright posts and right frame, wherein,

Left frame: the above has installed a long square terminal surface board and the below has Installed an enhancement board, and install a round-lack seat on the right end panel, and combined with the round-lack connected head of an even round-lack defend typhoon board;

Right frame: consists of several even round-lack overlap post, several even round-lack head defend typhoon board and several arc-round bottom seat, wherein,

Even round-lack overlaps post: the integrative shaping of two round-lack terminal surfaces;

Even round-lack head defend typhoon board: the present a long square body in the central, and it has installed a round-lack connected head in the ends of terminal surface with even round-lack head defend typhoon board;

Arc-round bottom seat: it present a arc in the ends and install two holes in the central; and

Upright post: It has installed a round-lack seat in the left of below, and combined with even round-lack head defend typhoon board;

Above-mentioned, an even round-lack overlaps post install in the ends of the even round-lack head defend typhoon board, and the present of the arrangement with symmetry mutually, in order to form An overlap one pair of semicircles for the folding typhoon defense combining structure.

2. An overlap one pair of semicircles for the folding typhoon defense combining structure to claim 1, wherein an even round-lack head defend typhoon board can be a round-lack connected head or cylinder connected head.

\* \* \* \* \*