

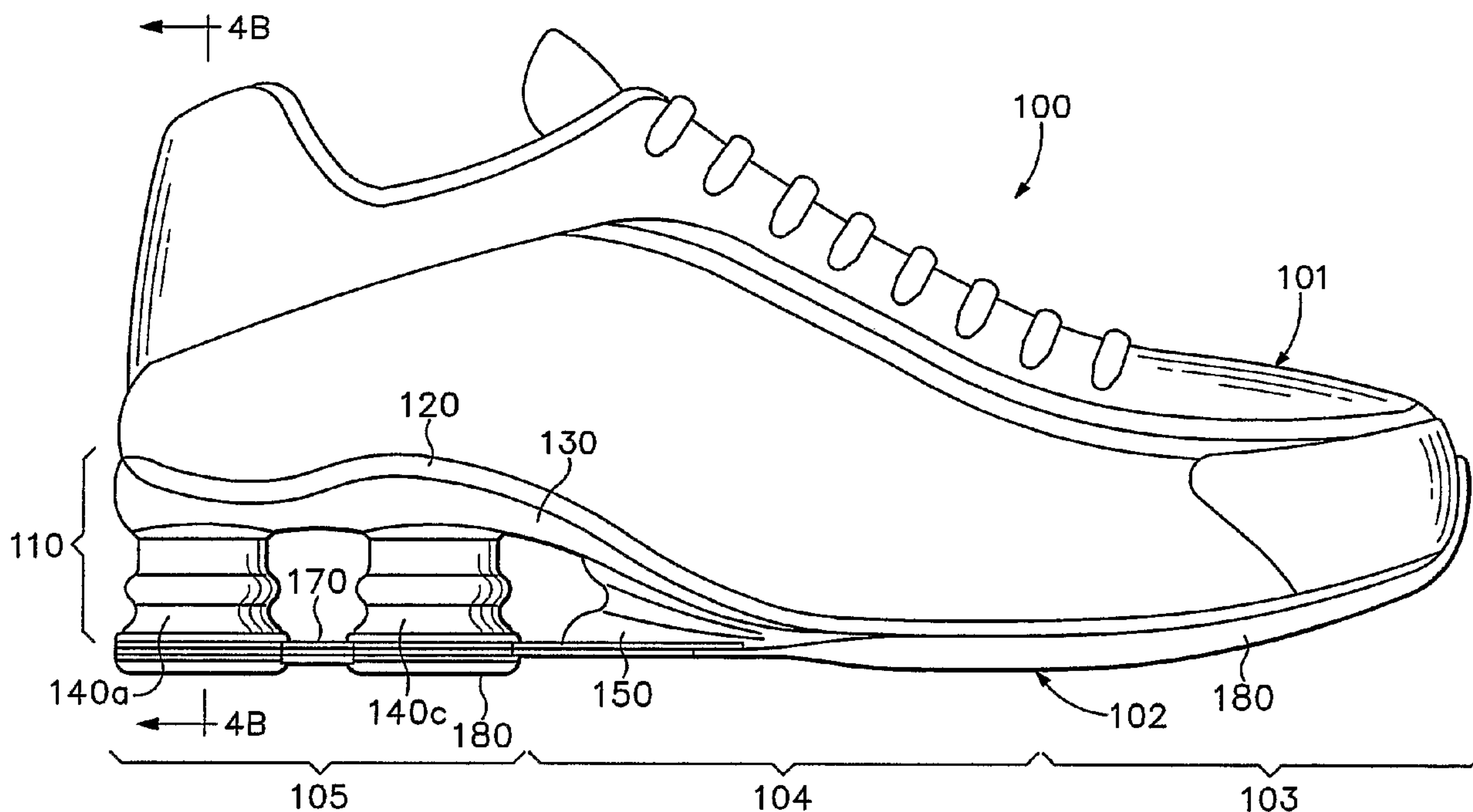

(86) Date de dépôt PCT/PCT Filing Date: 2004/01/07
 (87) Date publication PCT/PCT Publication Date: 2004/07/29
 (45) Date de délivrance/Issue Date: 2011/11/15
 (85) Entrée phase nationale/National Entry: 2005/07/05
 (86) N° demande PCT/PCT Application No.: US 2004/000008
 (87) N° publication PCT/PCT Publication No.: 2004/062412
 (30) Priorité/Priority: 2003/01/08 (US10/339,011)

(51) Cl.Int./Int.Cl. *A43B 13/18* (2006.01),
A43B 21/26 (2006.01), *A43B 3/24* (2006.01),
A43B 5/00 (2006.01)
 (72) Inventeurs/Inventors:
 SMALDONE, PATRICIA L., US;
 HURD, JOHN, US;
 HOFFER, KEVIN, US;
 SHEPERD, STANN NORMAN RICHARD, US
 (73) Propriétaire/Owner:
 NIKE INTERNATIONAL LTD., US
 (74) Agent: SMART & BIGGAR

(54) Titre : CHAUSSURE DONT LA STRUCTURE DE SEMELLE PRESENTE DES CARACTERISTIQUES REGLABLES
 (54) Title: ARTICLE OF FOOTWEAR HAVING A SOLE STRUCTURE WITH ADJUSTABLE CHARACTERISTICS



(57) Abrégé/Abstract:

The invention is a system for modifying characteristics of an article of footwear (100, 200, 300), particularly the sole structure (102, 202, 302). The footwear may include a plurality of discrete, vertically-projecting, columnar elements (140, 240, 340) that extend between upper and lower portions of a cavity formed in the sole structure. At least one of the columnar elements includes a void (141, 241) that is configured to receive an insert. The void (190, 290, 390) is accessible from the exterior of the footwear and the insert may be interchanged with an alternate insert that has different physical characteristics, thereby modifying the characteristics of the footwear.

(12) INTERNATIONAL APPLICATION PUBLISHED UNDER THE PATENT COOPERATION TREATY (PCT)

(19) World Intellectual Property
Organization
International Bureau



(43) International Publication Date
29 July 2004 (29.07.2004)

PCT

(10) International Publication Number
WO 2004/062412 A1

(51) International Patent Classification⁷: **A43B 13/18,**
5/00, 21/26

Bonanza Way, Tigard, OR 97224 (US). **HOFFER, Kevin**
[US/US]; 3205 NE 64th Avenue, Portland, OR 97213 (US).
SHEPERD, Stann, Norman, Richard [US/US]; 11165
NW Lost Park Drive, Portland, OR 97229 (US).

(21) International Application Number:
PCT/US2004/000008

(22) International Filing Date: 7 January 2004 (07.01.2004)

(74) Agent: **KUZARA, Byron, S.**; Banner & Witcoff, Ltd.,
11th Floor, 1001 G Street, NW, Washington, DC 20001-
4597 (US).

(25) Filing Language: English

(26) Publication Language: English

(81) Designated States (unless otherwise indicated, for every
kind of national protection available): AE, AG, AL, AM,
AT, AU, AZ, BA, BB, BG, BR, BW, BY, BZ, CA, CH, CN,
CO, CR, CU, CZ, DE, DK, DM, DZ, EC, EE, EG, ES, FI,
GB, GD, GE, GH, GM, HR, HU, ID, IL, IN, IS, JP, KE,
KG, KP, KR, KZ, LC, LK, LR, LS, LT, LU, LV, MA, MD,
MG, MK, MN, MW, MX, MZ, NA, NI, NO, NZ, OM, PG,
PH, PL, PT, RO, RU, SC, SD, SE, SG, SK, SL, SY, TJ, TM,
TN, TR, TT, TZ, UA, UG, US, UZ, VC, VN, YU, ZA, ZM,
ZW.

(30) Priority Data:
10/339,011 8 January 2003 (08.01.2003) US

(71) Applicant (for JP, KR only): **NIKE, INC.** [US/US]; One
Bowerman Drive, Beaverton, OR 97005 (US).

(71) Applicant (for all designated States except JP, KR, US):
NIKE INTERNATIONAL LTD. [GB/US]; One Bower-
man Drive, Beaverton, OR 97005 (US).

(72) Inventors; and

(75) Inventors/Applicants (for US only): **SMALDONE, Pa-**
tricia, L. [US/US]; 1248 NW Village Heights Drive, Port-
land, OR 97229 (US). **HURD, John** [US/US]; 10336 SW

(84) Designated States (unless otherwise indicated, for every
kind of regional protection available): ARIPO (BW, GH,
GM, KE, LS, MW, MZ, SD, SL, SZ, TZ, UG, ZM, ZW),
Eurasian (AM, AZ, BY, KG, KZ, MD, RU, TJ, TM), Euro-
pean (AT, BE, BG, CH, CY, CZ, DE, DK, EE, ES, FI, FR,

[Continued on next page]

(54) Title: ARTICLE OF FOOTWEAR HAVING A SOLE STRUCTURE WITH ADJUSTABLE CHARACTERISTICS

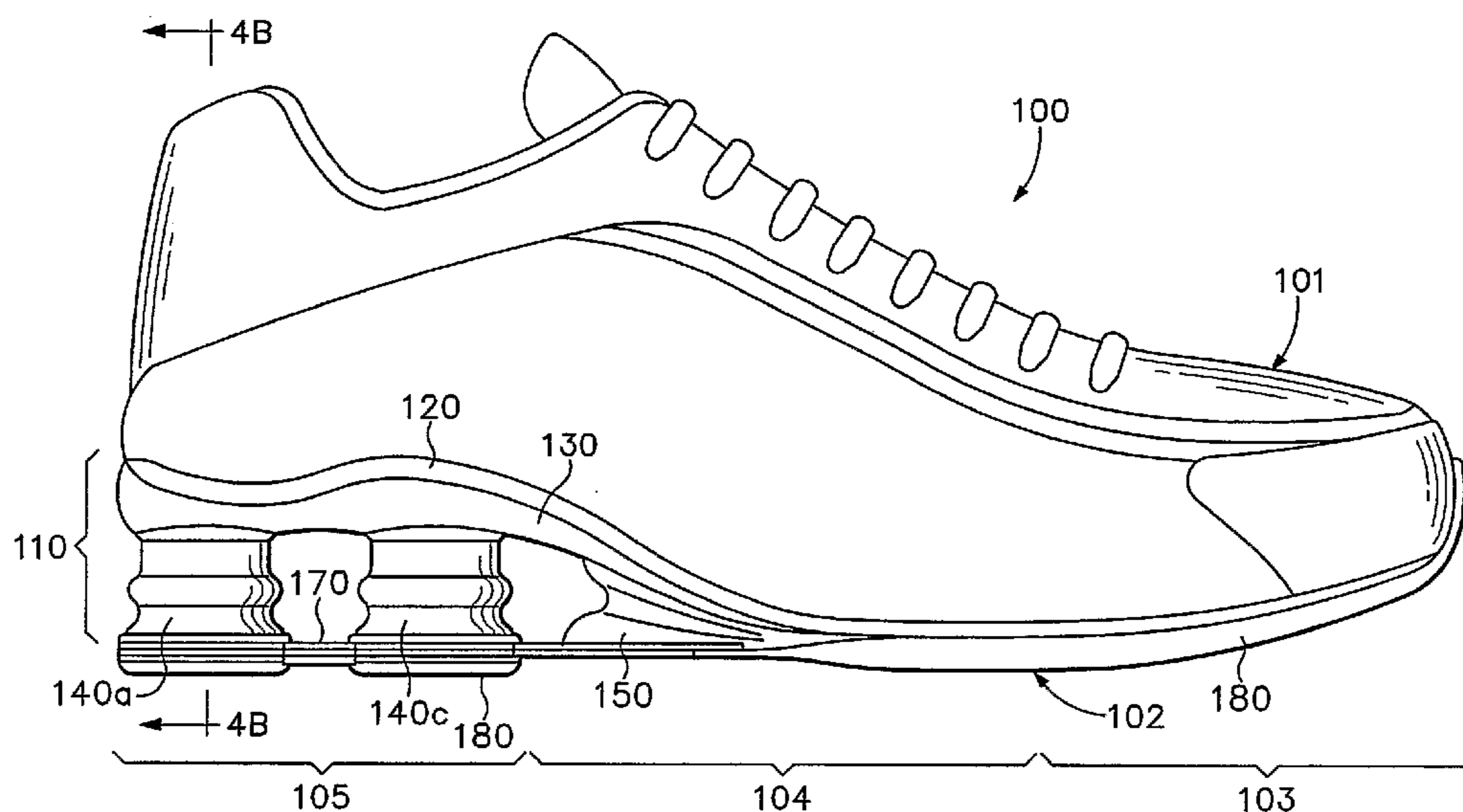

(57) Abstract: The invention is a system for modifying characteristics of an article of footwear (100, 200, 300), particularly the sole structure (102, 202, 302). The footwear may include a plurality of discrete, vertically-projecting, columnar elements (140, 240, 340) that extend between upper and lower portions of a cavity formed in the sole structure. At least one of the columnar elements includes a void (141, 241) that is configured to receive an insert. The void (190, 290, 390) is accessible from the exterior of the footwear and the insert may be interchanged with an alternate insert that has different physical characteristics, thereby modifying the characteristics of the footwear.

WO 2004/062412 A1

WO 2004/062412 A1



GB, GR, HU, IE, IT, LU, MC, NL, PT, RO, SE, SI, SK, TR), OAPI (BF, BJ, CF, CG, CI, CM, GA, GN, GQ, GW, ML, MR, NE, SN, TD, TG).

— *before the expiration of the time limit for amending the claims and to be republished in the event of receipt of amendments*

Published:

— *with international search report*

For two-letter codes and other abbreviations, refer to the "Guidance Notes on Codes and Abbreviations" appearing at the beginning of each regular issue of the PCT Gazette.

ARTICLE OF FOOTWEAR HAVING A SOLE STRUCTURE WITH
ADJUSTABLE CHARACTERISTICS

BACKGROUND OF THE INVENTION

Field of the Invention

- [01] The present invention relates to the field of footwear. The invention concerns, more particularly, a footwear sole structure with interchangeable inserts that modify characteristics of the sole structure.

Description of Background Art

- [02] Conventional articles of athletic footwear include an upper and a sole structure that are specifically designed for use in particular athletic activities. Running shoes, for example, incorporate a lightweight upper that provides the foot with ventilation, thereby decreasing the overall weight of the footwear and removing perspiration from the area surrounding the foot. Sole structures for running shoes are generally designed to provide a high degree of cushioning, which includes ground reaction force attenuation and energy absorption, and may incorporate motion control components for reducing the inward roll of the foot following footstrike. Basketball shoes generally incorporate an upper that protects the ankle from sprains and a sole that provides stability during the commonly executed lunges and quick direction changes. Finally, the sole structures for soccer shoes and football shoes may incorporate spikes that provide a high degree of traction on natural turf playing fields.
- [03] Despite the differences between the various footwear styles, sole structures for conventional footwear generally include multiple layers that are referred to as an insole, a midsole, and an outsole. The insole is a thin, cushioning member located adjacent to the

69275-218

foot that enhances footwear comfort. The midsole forms the middle layer of the sole and serves a variety of purposes that include controlling potentially harmful foot motions, such as over pronation; shielding the foot from excessive ground reaction forces; and beneficially utilizing such ground reaction forces for more efficient toe-off. The outsole forms the ground-contacting element of footwear and is usually fashioned from a durable, wear resistant material that includes texturing to improve traction.

[04] The primary element of a commonly-employed type of conventional midsole is a resilient, polymer foam material, such as polyurethane or ethylvinylacetate, that extends throughout the length and width of the footwear. In designing the midsole, footwear manufacturers balance the manner in which the midsole provides cushioning with stability. In general, a relatively thick midsole will provide greater cushioning than a relatively thin midsole, but will also have less stability than the relatively thin midsole.

[05] As an alternative, U.S. Patent Numbers 5,353,523 and 5,343,639 to Kilgore et al., discloses an article of athletic footwear with a midsole that includes foam columns placed between semi-rigid upper and lower plates. In general, the foam columns support the entire heel portion of the foot. The heel portion of a conventional article of footwear generally includes a block of foam material and may incorporate fluid-filled bladders, as disclosed in U.S. Patent Numbers 4,183,156 and 4,219,945 to Rudy. In contrast, the heel portion of the footwear disclosed in the Kilgore patents includes foam columns and a void that extends through the columns. Unlike many conventional midsole materials, therefore, the foam columns generally utilize a foam with higher density to provide greater support per unit-volume of foam material.

[06] The performance characteristics of the foam columns disclosed in the Kilgore patents are primarily dependent upon factors that include the dimensional configurations of the columns and the properties of the foam material selected for the columns. By designing

the columns to have specific dimensions and foam properties, cushioning and stability of the footwear may be generally tuned to meet the specific demands of the activity for which the footwear is intended to be used. In running shoes, for example, the dimensions and foam properties may be selected to provide greater cushioning. Similarly, the configuration of the columns may also be selected to provide enhanced stability in basketball shoes.

- [07] As stated above, cushioning and stability may be generally tuned to meet the specific demands of a particular activity. In general, the dimensions and foam properties will be selected to accommodate specific weights of the wearer, a generally preferred degree of cushioning, a particular activity, a specific ground surface, and a certain degree of motion control. A particular pair of footwear, however, may be purchased and worn by individuals with a wide range of weights that prefer different degrees of cushioning. In addition, the footwear may be used for varying activities on ground surfaces with a wide variety of compliance characteristics. In addition, different wearers may require different degrees of pronation or supination control. Predetermined column dimensions and foam properties may not be sufficient, therefore, to accommodate the requirements and preferences of all wearers that may utilize a particular pair of footwear.

SUMMARY OF THE INVENTION

- [08] The present invention is an article of footwear with an upper for receiving a foot of a wearer and a sole structure attached to the upper. The sole structure includes at least one discrete, vertically-projecting, columnar element positioned within a cavity formed in the sole structure. The columnar element includes a void that is accessible from an exterior of the footwear. The void receives a first insert that is removable from the void, and the sole structure may include a plurality of alternate inserts that are separate from the footwear. Each alternate insert has a physical property that is different from a physical

69275-218

property of the first insert, and each alternate insert is interchangeable with the first insert to modify a characteristic of the sole structure. The first insert and alternate inserts each include a first securing portion of a securing mechanism and the sole structure includes a corresponding securing portion of the securing mechanism. The first securing portion is joinable with the corresponding securing portion to secure one of the first insert and the alternate inserts within the void.

[09] The securing mechanism may have a variety of configurations within the scope of the present invention. For example, the first securing portion of the securing mechanism may include a protrusion, and the corresponding securing portion may be a channel, inclined plane, and receptacle formed in the sole structure. When properly placing the first insert into the void, the protrusion will travel upward through the channel, across the inclined plane, and become seated within the receptacle. Alternately, other types of securing mechanisms may be utilized to secure the first insert and the alternate inserts within the voids.

[10] The columnar element may be positioned between a top plate and a bottom plate formed of a rigid or semi-rigid material. The bottom plate is located adjacent an outsole, and both the bottom plate and the outsole form an aperture for receiving the inserts. The corresponding securing portion may be formed in the bottom plate. Alternately, however, the corresponding securing portion may be formed in the bottom plate and adjacent the aperture.

69275-218

According to another aspect of the invention, there is provided a method for modifying a characteristic of a sole structure for an article of footwear, said method comprising steps of: manufacturing at least one discrete, vertically-projecting, columnar element to include a substantially vertical void located on an interior of said columnar element; forming a cavity with an upper surface and an opposite lower surface in said sole structure, said cavity extending through a lateral side and a medial side of said footwear to form a horizontal aperture through the sole structure; locating said columnar element between said upper surface and said lower surface of said cavity; providing a first insert and a second insert that are separate from said sole structure and configured to be removably-received by said void; and supplying each of said first insert and said second insert with a first securing portion of a securing mechanism and supplying said sole structure with a corresponding second securing portion of said securing mechanism, said first securing portion being joinable with said second securing portion to secure one of said first insert and said second insert within said void.

According to still another aspect of the invention, there is provided a method for modifying a characteristic of a sole structure for an article of footwear, said method comprising steps of: manufacturing at least one discrete, vertically-projecting, columnar element to include an exterior surface and a substantially vertical void located on an interior of said columnar element; forming a cavity with an upper surface and an opposite lower surface in said sole structure, said cavity extending through a lateral side and a medial side of said footwear to form a horizontal aperture through the sole structure; locating said columnar element between said upper surface and said lower surface of said cavity such that said exterior surface is exposed within said cavity; providing a first insert and a second insert that are separate from said sole structure and configured to be removably-received by said void, said first insert and said second insert being formed to have different physical properties; supplying each of said first insert and said second insert with a first securing portion of a securing mechanism and supplying said sole structure with a corresponding second securing portion of said securing mechanism, said first securing portion being joinable with said second securing

69275-218

portion to secure one of said first insert and said second insert within said void; and selecting one of: a first configuration, wherein said first insert is received by said void, a second configuration, wherein said second insert is received by said void, and a third configuration, wherein neither said first insert nor said second insert are
5 received by said void.

According to yet another aspect of the invention, there is provided an article of footwear having an upper for receiving a foot of a wearer and a sole structure attached to said upper, said sole structure comprising: a
10 vertically-projecting, columnar element positioned between upper and lower surfaces of a cavity formed within said sole structure and having a substantially vertical void located on an interior of said columnar element, said cavity having an upper surface and an opposite lower surface, and said cavity extending through a lateral side and a medial side of said footwear to form a horizontal opening in said sole structure, said
15 columnar element being positioned to extend between said upper surface and said lower surface; and at least one insert dimensioned to be received by said void, said at least one insert including a first securing portion of a securing mechanism and said sole structure including a corresponding second securing portion of said securing mechanism, said first securing portion joining with said second securing portion to secure said at least one insert within said void.

20 According to a further aspect of the invention, there is provided an article of footwear having an upper for receiving a foot of a wearer and a sole structure attached to said upper, said sole structure comprising: a plurality of vertically-projecting, columnar elements extending between an upper surface and a lower surface of a cavity that is formed in a heel portion of said sole structure, said
25 columnar elements including a first columnar element having a substantially vertical void located on an interior of said first columnar element, and said cavity extending through a lateral side and a medial side of said footwear to form a horizontal aperture through said sole structure; a first insert formed of a first material and located within said void, said first insert including a first securing portion of a securing mechanism,
30 and said sole structure including a corresponding second securing portion of said securing mechanism, said first securing portion being joined with said second securing portion to releasably-secure said first insert within said void; and a second

69275-218

insert formed of a second material and positioned outside of said void, said second insert being dimensioned to be received by said void upon removal of said first insert.

According to a still further aspect of the invention, there is provided an article of footwear having an upper for receiving a foot of a wearer and a sole structure attached to said upper, said sole structure comprising: a plurality of discrete, vertically-projecting, columnar elements formed of a compressible material and located between upper and lower surfaces of a cavity within said sole structure, said columnar elements including a first columnar element with a substantially vertical void located on an interior of said first columnar element, and said cavity extending through a lateral side and a medial side of said footwear to form a horizontal aperture through said sole structure; a first insert that is positioned within said void, said first insert including a first securing portion of a securing mechanism that joins with a corresponding securing portion of said securing mechanism to secure said first insert within said void; and a plurality of second inserts that are located outside of said void, said second inserts each having a physical property that differs from a physical property of said first insert, said second inserts being interchangeable with said first insert to modify a characteristic of said sole structure, and said second inserts each including a second securing portion of said securing mechanism, said second securing portion being joinable with said corresponding securing portion to secure one of said second inserts within said void.

According to a yet further aspect of the invention, there is provided an article of footwear having an upper for receiving a foot of a wearer and a sole structure attached to said upper, said sole structure comprising: a midsole having a cavity located within a heel portion of said footwear, said midsole including a plurality of discrete, vertically-projecting, columnar elements formed of a compressible material and located within said cavity, said columnar elements extending between upper and lower portions of said cavity to provide support for the foot, and said columnar elements including a first columnar element with a substantially vertical void located on an interior of said first columnar element, and said cavity extending through a lateral side and a medial side of said footwear to form a horizontal aperture through said sole structure; an outsole attached to at least a portion of a lower surface of said midsole, said outsole including an aperture that provides access to

69275-218

said void; a first insert that is separate from said sole structure, said first insert being dimensioned to extend through said aperture and into said void, said first insert including a first securing portion of a securing mechanism and said sole structure including a corresponding securing portion of said securing mechanism, said first
5 securing portion joining with said corresponding securing portion to secure said first insert within said void; and a plurality of second inserts that are separate from said sole structure, said second inserts each having a physical property that differs from a physical property of said first insert, said second inserts being dimensioned to extend through said aperture and into said void, said second inserts being interchangeable
10 with said first insert to modify a characteristic of said sole structure, and said second inserts including a second portion of said securing mechanism, said second portion joining with said corresponding securing portion to secure one of said second inserts within said void.

According to another aspect of the invention, there is provided an article
15 of footwear having an upper for receiving a foot of a wearer and a sole structure attached to said upper, said sole structure comprising: a discrete, vertically-projecting, columnar element positioned between upper and lower surfaces of a cavity formed within said sole structure and having a substantially vertical void located on an interior of said columnar element; an outsole positioned to form a lower
20 surface of said sole structure, said outsole forming an outsole aperture located below said void; a plate formed of a semi-rigid material and positioned between said columnar element and said outsole, said plate forming a plate aperture located below said void; and at least one insert dimensioned to be received by said void, said at least one insert including a first securing portion of a securing mechanism and said
25 plate aperture including a corresponding second securing portion of said securing mechanism, said first securing portion joining with said second securing portion to secure said at least one insert within said void.

According to still another aspect of the invention, there is provided an article of footwear having an upper for receiving a foot of a wearer and a sole
30 structure attached to said upper, said sole structure comprising: a plurality of discrete, vertically-projecting, columnar elements formed of a compressible material and located between upper and lower surfaces of a cavity within said sole structure,

69275-218

said columnar elements including a first columnar element with a substantially vertical void located on an interior of said first columnar element, and said cavity extending through a lateral side and a medial side of said footwear to form a horizontal aperture through said sole structure; a plate formed of a semi-rigid material positioned below said columnar elements, said plate defining an aperture that is aligned with said void to provide access to said void; a first insert that is positioned within said void, said first insert including a first securing portion of a securing mechanism that joins with a corresponding securing portion of said securing mechanism to secure said first insert within said void, said corresponding securing portion being located in said aperture; and a plurality of second inserts that are located outside of said void, said second inserts each having a physical property that differs from a physical property of said first insert, said second inserts being interchangeable with said first insert to modify a characteristic of said sole structure, and said second inserts each including a second securing portion of said securing mechanism, said second securing portion being joinable with said corresponding securing portion to secure one of said second inserts within said void.

[11] The advantages and features of novelty characterizing the present invention are pointed out with particularity in the appended claims. To gain an improved understanding of the advantages and features of novelty, however, reference may be made to the following descriptive matter and accompanying drawings that describe and illustrate various embodiments and concepts related to the invention.

DESCRIPTION OF THE DRAWINGS

- [12] The foregoing Summary of the Invention, as well as the following Detailed Description of the Invention, will be better understood when read in conjunction with the accompanying drawings.
- [13] Figure 1 is a lateral elevation view of an article of footwear in accordance with a first embodiment of the present invention.
- [14] Figure 2 is an exploded perspective view of a portion of a sole structure of the footwear depicted in Figure 1.
- [15] Figure 3 is a top plan view of the portion depicted in Figure 2.
- [16] Figure 4A is a cross-sectional view, as defined by line 4A-4A in Figure 3.
- [17] Figure 4B is a cross-sectional view, as defined by line 4B-4B in Figure 1.
- [18] Figure 5 is a perspective view of the footwear with a plurality of alternate inserts.
- [19] Figure 6 is a lateral elevation view of an article of footwear in accordance with a second embodiment of the present invention.
- [20] Figure 7 is an exploded perspective view of a portion of a sole structure of the footwear depicted in Figure 6.
- [21] Figure 8 is a top plan view of the portion depicted in Figure 7.
- [22] Figure 9 is a cross-sectional view, as defined by line 9-9 in Figure 8.
- [23] Figure 10 is a lateral elevation view of an article of footwear in accordance with a third embodiment of the present invention.

- [24] Figure 11 is an exploded perspective view of a portion of a sole structure of the footwear depicted in Figure 10.
- [25] Figure 12 is a top plan view of the portion depicted in Figure 11.
- [26] Figure 13 is a cross-sectional view, as defined by line 13-13 in Figure 12.

DETAILED DESCRIPTION OF THE INVENTION

Introduction

- [27] Referring to the figures and following discussion, articles of footwear 100, 200, and 300 in accordance with the present invention are disclosed. Footwear 100 and 200 are depicted and discussed as running shoes, and footwear 300 is depicted and discussed as a basketball shoe. The concepts disclosed with respect to footwear 100, 200, and 300 may, however, be applied to a wide range of other athletic footwear styles, including walking shoes, tennis shoes, soccer shoes, football shoes, and cross-training shoes, for example. In addition, the concepts of the present invention may be applied to a wide range of non-athletic footwear, including work boots, sandals, loafers, and dress shoes. Accordingly, the present invention is not limited to the precise embodiments disclosed herein, but applies to footwear generally.

First Embodiment

- [28] Footwear 100 is depicted in Figures 1-5 and includes an upper 101 that is connected to a sole structure 102. Upper 101 may be a conventional or non-conventional upper that includes, for example, layers of foam materials, synthetic textiles, and leather that are stitched or adhesively bonded to each other to form a comfortable structure for receiving a foot. Sole structure 102 may include an insole which is a thin cushioning member generally located within upper 101 and at a position that corresponds with the sole of the

foot, thereby enhancing the comfort of footwear 100. Sole structure 102 also includes a midsole 110 that forms the primary cushioning layer of footwear 100 and serves, therefore, to attenuate ground reaction forces and absorb energy when footwear 100 is compressed against the ground. The primary components of midsole 110 are a foam layer 120, a top plate 130, four columnar elements 140a-140d, a midfoot wedge 150, rings 160, and a bottom plate 170. In addition, sole structure 102 includes an outsole 180 and a plurality of inserts 190a-190d. Outsole 180 forms the primary ground-contacting surface of footwear 100 and may be fashioned from a wear-resistant material, such as carbon black rubber compound, and may include texturing to enhance traction. Inserts 190a-190d are removable from footwear 100 and extend through outsole 180 and into midsole 110. More particularly, inserts 190a-190d are configured to extend into interior portions of columnar elements 140a-140d, respectively.

- [29] During running or other activities that compress sole structure 102 between the foot and the ground, footwear 100 provides the individual with cushioning. That is, footwear 100 attenuates ground reaction forces and absorbs energy that would otherwise be transferred to the leg and foot of the individual. The degree of cushioning provided by footwear 100 is generally related to the overall stiffness of sole structure 102. In general, a greater stiffness corresponds with lesser cushioning, whereas lesser stiffness corresponds with greater cushioning. Accordingly, stiffness and cushioning are generally correlated through an inverse relationship.
- [30] In conventional footwear, the stiffness of the sole structure is predetermined by the footwear manufacturer. Not all individuals, however, require or prefer the specific degree of stiffness that is predetermined by the footwear manufacturer. Individuals of different mass may prefer a sole structure that provides different degrees of stiffness. At a minimum, however, the selected stiffness should be sufficient to prevent top plate 130 from contacting bottom plate 170 as the person walks, runs, jumps, or otherwise

compresses sole structure 102. Some individuals may also prefer a sole structure that exhibits lesser stiffness for some activities and greater stiffness for other activities. In addition, individuals may prefer greater stiffness on compliant surfaces, such as dirt, turf, or sand, and lesser stiffness on non-compliant surfaces, such as concrete or asphalt. Furthermore, an individual who over-pronates or over-supinates may prefer that the lateral side and the medial side of an article of footwear exhibit different degrees of stiffness.

[31] In contrast with conventional articles of footwear that have predetermined degrees of stiffness in the sole structure, footwear 100 incorporates an adjustment mechanism that permits an individual to modify the stiffness characteristics, as well as other characteristics, of sole structure 102. The primary determinant of the stiffness in sole structure 102 is the combination of columnar elements 140a-140d and inserts 190a-190d. As discussed above, inserts 190a-190d extend through outsole 180 and into columnar elements 140a-140d, respectively. By varying the physical properties of inserts 190a-190d, the stiffness of sole structure 102 may be altered, as discussed in greater detail below. In addition to the stiffness of sole structure 102, characteristics such as the manner in which sole structure 102 controls the motion of the foot may be modified, for example.

[32] The various elements of sole structure 102 will now be discussed in detail. To aid in the following discussion, footwear 100 may be divided into three general regions: a fore region 103 that generally corresponds with a front portion of the foot, including the toes; a midfoot region 104 that generally corresponds with a middle portion of the foot that includes the arch; and a heel region 105 that generally corresponds with the heel. Regions 103-105 are not intended to demarcate precise areas of footwear 100. Instead, regions 103-105 are intended to define general areas that aid in the following discussion.

- [33] Foam layer 120 is attached directly to upper 101 throughout the length of footwear 100 and supplies a portion of the cushioning provided by sole structure 102. In fore region 103, foam layer 120 extends between upper 101 and outsole 180. In heel region 105 and a portion of midfoot region 104, however, foam layer 120 extends between upper 101 and top plate 130. An upper surface of foam layer 120 may be contoured to conform to the shape of the foot. Accordingly, foam layer 120 may include a raised arch on the medial side of midfoot region 104, raised peripheral areas extending around sides of the foot, and a depression for receiving the heel, for example. The thickness of foam layer 120 may vary along the length of footwear 100. For example, foam layer 120 may have a relatively constant thickness in heel region 105 and midfoot region 104. In fore region 103, however, the thickness of foam layer 120 may decrease to a point at the front of footwear 100. Suitable materials for foam layer 120 include foam materials, such as ethylvinylacetate and polyurethane foam, which are commonly incorporated into the midsoles of conventional footwear.
- [34] Top plate 130 is attached to the lower surface of foam layer 120 in heel region 105 and midfoot region 104. The upper surface of top plate 130 may form a depression for receiving the heel. The lower surface of top plate 130 is connected to columnar elements 140a-140d, and the primary purpose of top plate 130 is to provide a semi-rigid structure that supports the foot in heel region 105 and distributes forces among columnar elements 140a-140d. Suitable materials for top plate 130 include a plurality of lightweight, durable polymer materials having a moderate flexural modulus, such as polyester, nylon, or a polyether block copolyamide. Top plate 130 may also be formed of a composite material that is a combination of a polymer and a plurality of fibers or particulates, such as glass or carbon fibers. Footwear 100 is structured to support the foot such that the heel is raised above the toes, with the transition from the higher heel area to the lower toe area

occurring in midfoot region 104. Accordingly, top plate 130 is generally horizontal in heel region 105, but angles downward in midfoot region 104 to provide the transition.

- [35] Columnar elements 140a-140d are vertically-projecting components that, in combination with inserts 190a-190d, are the primary determinant of the stiffness in sole structure 102. As depicted in Figures 1-5, footwear 100 includes four columnar elements 140a-140d that are positioned as follows: columnar element 140a is positioned in a rear-lateral corner of footwear 100; columnar element 140b is positioned in a rear-medial corner of footwear 100; columnar element 140c is positioned forward of columnar element 140a and on a lateral side of footwear 100; and columnar element 140d is positioned forward of columnar element 140b and on a medial side of footwear 100. Alternately, footwear 100 may include a lesser or greater number of columnar elements 140a-140d, and columnar elements 140a-140d may be positioned in other portions of footwear 100, including fore region 103 and midfoot region 104.
- [36] Columnar elements 140a-140d have a vertically-projecting structure and are positioned within a cavity formed between top plate 130 and bottom plate 170. Each columnar element 140a-140d, therefore, extends upward between bottom plate 170 and top plate 130 to provide support for top plate 130 in heel area 105. As depicted, columnar elements 140a-140d have a generally cylindrical structure, but may have a plurality of other structural shapes within the scope of the present invention, including the shape of a cone, a pyramid, a cube, or a sphere, for example. The exterior surface of columnar elements 140a-140d may be smooth, or may include contours. As depicted in the figures, columnar elements 140a-140d each have a protrusion that circumscribes an exterior surface of columnar elements 140a-140d. In alternate embodiments, columnar elements 140a-140d may include a separate ring that is seated within an indentation in the exterior surface, or may include no ring. Accordingly, columnar elements 140a-140d may have a wide range of configurations within the scope of the present invention.

- [37] As depicted in the figures, columnar elements 140a-140d each include a void 141 that extends along longitudinal axes of columnar elements 140a-140d. Within the scope of the present invention, however, it is not necessary that all columnar elements 140a-140d include a void 141. In certain applications, only one of columnar element 140a-140d may include a void 141. In general, voids 141 are configured to receive one of a plurality of inserts 190a-190d. Columnar elements 140a-140d may also be connected by an integral base 142. Despite the presence of base 142, columnar elements 140a-140d have a discrete configuration wherein each individual columnar element 140a-140d extends in the upward direction.
- [38] In combination with inserts 190a-190d, columnar elements 140a-140d determine the overall stiffness in sole structure 102. As discussed above, stiffness is related to cushioning. Columnar elements 140a-140d supply a significant portion of the cushioning provided by sole structure 102, and the materials selected for columnar elements 140a-140d should promote this purpose. Suitable materials for columnar elements 140a-140d are rubber, ethylvinylacetate, or polyurethane foam, for example, that returns energy in the range of at least 35 to 70% in a drop ball rebound test. Furthermore, a suitable material may have sufficient durability to maintain structural integrity when repeatedly compressed from 50 to 70% of its natural height in excess of 500,000 cycles. In addition, a microcellular foam having a specific gravity of 0.5 to 0.7 g/cm³, a hardness of 70 to 76 on the Asker C scale, and a stiffness of 110 to 130 kN/m at 60% compression may be utilized. Alternatively, a microcellular elastomeric foam of the type disclosed in U.S. Patent Numbers 5,353,523 and 5,343,639 to Kilgore et al., which have been incorporated by reference and discussed in the Description of Background Art section herein, may be utilized.
- [39] In addition to columnar elements 140a-140d, the area between top plate 130 and bottom plate 170 also includes midfoot wedge 150 which is positioned forward of columnar

elements 140a-140d. The function of midfoot wedge 150 is to absorb impact forces and provide support to midfoot region 104 of footwear 100, thereby preventing a collapse of top plate 130 in midfoot region 104. An upper surface of midfoot wedge 150 is attached, possibly with an adhesive, to top plate 130. Similarly, a lower surface of midfoot wedge 150 is attached to bottom plate 170. Suitable materials for midfoot wedge 150 include the materials discussed above for columnar elements 140a-140d.

- [40] Each columnar element 140a-140d may extend around one of rings 160. As depicted in Figure 4A, a portion of bottom plate 170 may extend into voids 141 so as to contact rings 160. One purpose for rings 160 is to prevent overinsertion of inserts 190a-190d. Alternately, bottom plate 170 may be formed to achieve a similar purpose. Suitable materials for rings 160 include the materials discussed in relation to top plate 130.
- [41] Bottom plate 170 is positioned below columnar elements 140a-140d and rings 160, and may extend into midfoot region 104, thereby extending under midfoot wedge 150. Like top plate 130, bottom plate 170 provides a semi-rigid structure that distributes forces among columnar elements 140a-140d. When outsole 180 is compressed against the ground, an upward force is directed into bottom plate 170. If bottom plate 170 were formed of a highly flexible material, only the columnar elements 140a-140d located directly above the point of contact between outsole 180 and the ground would experience a compressive force.
- [42] Bottom plate 170 includes four apertures 171 that are aligned with voids 141 of columnar elements 140a-140d. As will be discussed in greater detail below, inserts 190a-190d extend into voids 141 by protruding through outsole 180 and bottom plate 170. Apertures 171, therefore, provide inserts 190a-190d with access to voids 141. In addition to providing access, apertures 171 also include a portion of a securing mechanism that secures the position of inserts 190a-190d in voids 141. The portion of the securing

mechanism located in each aperture 171 includes channels 172, inclined planes 173, and receptacles 174, which will be described in greater detail below.

- [43] Outsole 180 is attached to a lower surface of bottom plate 170 in heel region 105 and midfoot region 104. In fore region 103, however, outsole 180 is attached to the lower surface of foam layer 120. Outsole 180 forms the primary ground-contacting surface of footwear 100 and may be fashioned from a wear-resistant material, such as carbon black rubber compound, that includes texturing to enhance traction. Like bottom plate 170, outsole 180 includes apertures 181 that are aligned with voids 141, and grooves 183 that are aligned with channels 172, thereby providing inserts 190a-190d with access to voids 141 through outsole 180. Outsole 180 may also include caps 182 that are positioned within apertures 181 and protect inserts 190a-190d from wear. Caps 182 may be formed from the same material that forms outsole 180, and caps 182 may be held in position by friction, for example. In addition, caps 182 may be permanently secured to inserts 190a-190d.
- [44] Inserts 190a-190d are configured to protrude through apertures 181 and 171, thereby extending into voids 141 of columnar elements 140a-140d, respectively. Each insert 190a-190d will generally be formed of a first portion 191 and a second portion 192 that are connected with an adhesive or molded as one unit, for example. First portions 191 form the majority of inserts 190a-190d and are positioned within voids 141 when inserts 190a-190d are connected to footwear 100. First portions 191 may be formed from a variety of materials having varying degrees of stiffness, compliance, and compressibility. In general, however, the materials forming first portions 191 will be similar to the materials that form columnar elements 140a-140d, but may have different material properties. Second portions 192 do not generally extend entirely into voids 141 and are primarily located within apertures 171 and 181 when inserts 190a-190d are connected to footwear 100. Suitable materials for second portions 192 may be a more rigid and

durable material than the materials forming first portions 191, and may include the materials discussed in relation to top plate 130 and bottom plate 170. Alternately, the material forming second portions 192 may be the same as the material forming first portion 191. Second portions 192 also include one or more protrusions 193 that form a corresponding portion of the securing mechanism that secures the position of inserts 190a-190d in voids 141.

[45] Upon inserting an individual one of inserts 190a-190d through apertures 171 and 181 and into void 141, first portion 191 will generally contact at least a portion of the surface of columnar elements 140a-140d, thereby filling a substantial portion of void 141, and second portion 192 will be positioned within apertures 171 and 181. In order to properly position second portion 192 in apertures 171 and 181, protrusions 193 travel upward through grooves 183 and channels 172. The selected one of insert 190a-190d is then rotated so that protrusions 193 slide along inclined planes 173 and drop into receptacles 174 formed in bottom plate 170. Accordingly, protrusions 193 are securely positioned within receptacles 174 when inserts 190a-190d are properly positioned with respect to footwear 100. Although inserts 190a-190d may be removable and insertable with the fingers of the individual, a removal device may also be supplied to assist with removal and insertion. As depicted in Figure 4A, second portion 192 forms an indentation 194 that will receive the removal device, which may be any article that assists with the removal and insertion of inserts 190a-190d, and may be a common object, such as a screwdriver, a fingernail, or coin-type currency. A slot is also formed in cap 182 to provide the removal device with access to indentation 194.

[46] Inserts 190a-190d are depicted in Figure 4A as extending slightly above the top surface of columnar elements 140a-140d. When inserted into footwear 100, therefore, inserts 190a-190d are slightly compressed. In alternate embodiments, however, inserts 190a-

190d may have a length that corresponds with the top surface of columnar elements 140a-140d or extends below the top surface of columnar elements 140a-140d.

- [47] Inserts 190a-190d may be structured to include indentations that circumscribe the exterior surface of first portion 191. The indentations may be utilized to identify the characteristics of inserts 190a-190d. For example, a ring located adjacent top portions of inserts 190a-190d may indicate a relatively hard material, whereas a ring located adjacent bottom portions of inserts may indicate a relatively soft material. Other indicia, such as numbers imprinted into the surface of inserts 190a-190d or differing colors are alternate ways of identifying the material characteristics.
- [48] The operation of the present invention will be discussed in greater detail with reference to Figure 5. Assume for purposes of the present discussion that footwear 100 is initially configured such that each void 141a-141d includes an identical insert 190a-190d, respectively. In this configuration, columnar elements 140a-140d, which are substantially identical in configuration and material, will encompass inserts 190a-190d, which are also substantially identical in configuration and material. Heel region 105 will, therefore, have four combinations of columnar elements 140a-140d and inserts 190a-190d that have substantially identical stiffness characteristics. This configuration may be suitable for an individual that does not over-pronate, but an individual that does over-pronate may desire sole structure 102 to have lesser stiffness in the rear-lateral corner than in other portions of heel region 105. In order to alter the stiffness characteristics of sole structure 102, the individual may replace insert 190a with alternate insert 190a'. If first portion 191 of alternate insert 190a' is formed of a material that is less stiff than first portion 191 of insert 190a, then insertion of alternate insert 190a' into void 141a will decrease the stiffness of sole structure 102 in the rear-lateral corner, thereby providing the individual with a measure of pronation control. Accordingly, the act of replacing inserts

190a-190d with alternate inserts 190a'-190d' that have different physical properties alters the characteristics of sole structure 102.

- [49] The physical characteristics that may differ between various inserts 190a-190d may relate to a variety of factors, including the materials from which inserts 190a-190d are formed, the specific properties of the materials, the shape of inserts 190a-190d, and the size of inserts 190a-190d, for example. In the above example, insert 190a may be formed of a foamed polyurethane, whereas alternate insert 190a' may be formed of a microcellular foam. Similarly, insert 190a and alternate insert 190a' may be formed from the same material, but with different densities. In addition to being formed from different materials, insert 190a and alternate insert 190a' may have different shapes, different circumferences, or different lengths, for example. Accordingly, the present invention encompasses a broad range of physical characteristics that may differ between the various inserts 190a-190d and alternate inserts 190a'-190d'.
- [50] Pronation control is not the only purpose for the present invention. As discussed above, not all individuals require or prefer the specific degree of stiffness that is predetermined by the footwear manufacturer. Individuals of different mass may prefer a sole structure that provides different degrees of stiffness. Accordingly, the individual may replace all inserts 190a-190d with alternate inserts 190a'-190d' that have a different stiffness to thereby change the overall stiffness of sole structure 102 in a desired manner. Similarly, an individual that is running on a compliant surface, such as turf or sand, may prefer that sole structure 102 have a greater stiffness. Accordingly, the individual may replace inserts 190a-190d with alternate inserts 190a'-190d' that have greater stiffness to thereby increase the overall stiffness of sole structure 102. Individuals may also find that varying the characteristics of sole structure 102 configures footwear 100 to be more suitable for specific activities, such as running versus walking.

[51] The above discussion focuses upon alterations in the stiffness of sole structure 102 that are achieved by replacing one insert 190a-190d with an alternate insert 190a'-190d'. The structure of columnar elements 140a-140d may be designed to support the individual without the addition of inserts 190a-190d. Accordingly, the individual may opt to entirely remove one or more inserts 190a-190d to configure specific columnar elements 140a-140d for the least possible degree of stiffness.

Second Embodiment

[52] A second embodiment of the present invention is disclosed in Figures 6-9 with reference to footwear 200. The primary elements of footwear 200 are an upper 201 and a sole structure 202 that is attached to upper 201. Sole structure 202 includes a midsole 210, an outsole 280, and a plurality of inserts 290. Midsole 210 further includes a foam layer 220, a top plate 230, four columnar elements 240, a midfoot wedge 250, and a bottom plate 270. Note that the design of midsole 210, as depicted in the figures, does not include rings that correspond with rings 160 of footwear 100. Different embodiments of the present invention may, therefore, have different elements to achieve the characteristic-modifying purpose of the present invention.

[53] Columnar elements 240 have a general shape of a truncated cone and a wall thickness that is significantly thinner than the wall thickness in columnar elements 140a-140d. In the absence of inserts 290, columnar elements 240 would be unable to support the weight of the individual. Although this may seem to be an undesirable quality of footwear 200, this characteristic provides the individual greater control over the characteristics of sole structure 202. With reference to footwear 100, columnar elements 140a-140d have a thickness that is sufficient to fully support the individual. Accordingly, columnar elements 140a-140d play a significant part in determining the overall characteristics of sole structure 102. In footwear 200, however, columnar elements 240 provide significantly less support. Accordingly, inserts 290 are the primary determinant of the

characteristics of sole structure 202. Inserts 290 that have a specific range of physical properties will, therefore, have a significant effect upon the overall characteristics of sole structure 202, whereas inserts 190a-190d having the same range of physical properties will not alter the characteristics of sole structure 102 to the same degree due to the effect that the thickness of columnar elements 140a-140d has upon the characteristics. Accordingly, columnar elements 240 will have little to no affect upon the overall modifiability of sole structure 202.

- [54] Columnar elements 240 may be formed from the materials discussed relative to columnar elements 140a-140d. Due to the reduced wall thickness of columnar elements 240, however, a material that is at least semi-transparent may be utilized to permit the individual to see inserts 290. Such materials include certain formulations of thermoplastic polyurethane, nylon, and rubber, for example. This not only has the potential to provide a unique aesthetic characteristic to footwear 200, but also permits the individual to see inserts 290, which may have indicia to identify their specific physical characteristics.
- [55] Each insert 290 includes a first portion 291 and a second portion 292 formed of different materials. Whereas first portion 291 extends into voids 241 of columnar elements 240, second portion 292 protrudes through apertures 271 in bottom plate 270 and apertures 281 in outsole 280. First portion 291 may be formed of a variety of materials or have varying dimensions that provide differing ranges of characteristics. Second portion 292 may be formed of a semi-rigid material that is suitable for a securing mechanism that securely holds inserts 290 within columnar elements 240. In contrast with the securing mechanism of footwear 100, bottom plate 270 includes a protrusion 272 and each insert 290 includes a channel 293, an inclined plane 294, and a receptacle 295 that operate to guide and seat protrusion 272 when securing inserts 290 within columnar elements 240. Accordingly, the securing mechanism operates in a manner that is similar to the securing

mechanism of footwear 100. Inserts 290 also include a permanently affixed cap 296 attached to a lower surface of second portion 292.

- [56] Footwear 200 is disclosed in the figures and discussed in relation to the structure of a running shoe. In further embodiments, however, columnar elements having the general structure and characteristics of columnar elements 240 may be incorporated into other styles of footwear, such as basketball shoe, for example. When incorporated into basketball shoes, columnar elements 240 may be modified to have a canted upper surface that is similar to the upper surface disclosed in the following discussion with respect to footwear 300.

Third Embodiment

- [57] Footwear 100 and footwear 200 are two embodiments of the present invention that are disclosed with reference to running shoes. Footwear 300 is depicted in Figures 10-13 and discloses the present invention with respect to a basketball shoe. The primary elements of footwear 300 are an upper 301 and a sole structure 302 that is attached to upper 301. Sole structure 302 includes a midsole 310, an outsole 380, and a plurality of inserts 390. Midsole 310 further includes a top plate 330 that extends around the heel of the wearer, four columnar elements 340 that have a canted upper surface, a midfoot wedge 350, and a bottom plate 370. In contrast with the prior embodiments, columnar elements 340 and midfoot wedge 350 are formed integral with a common base 320. Footwear 300 may also include caps 382 that are positioned under inserts 390.
- [58] As with the prior embodiments, inserts 390 may be interchanged with alternate inserts 390 to modify the stiffness of sole structure 302. In general, the range of motions inherent in the game of basketball is much greater than the range of motions utilized in running. For example, basketball commonly requires quick direction changes, lunges, and jumping. The footwear utilized in basketball, therefore, is generally more stable than

the footwear utilized for running. To promote stability in sole structure 302, columnar elements 340 may be spaced in a relatively wide relationship in the medial-lateral direction. Furthermore, removing and replacing inserts 390 modifies to the overall characteristics of sole structure 302 to modify the stiffness and stability to the preferences of the individual.

[59] As depicted, footwear 300 includes a securing system that is similar to the securing system incorporated into footwear 100. However, either of the securing systems disclosed with respect to footwear 100 or footwear 200 may be employed in footwear 300. Footwear 300 may also incorporate one of a plurality of alternate securing systems. For example, bottom plate 370 may be threaded and inserts 390 may include corresponding threads. In addition, bottom plate 370 may include a protrusion that mates with an indentation in inserts 390. As disclosed above, the corresponding portions of the securing systems are located on the various bottom plates 170, 270, and 370 and the inserts 190a-190d, 290, and 390. In alternate embodiments, the securing system may also be incorporated into the various columnar elements 140a-140d, 240, and 340, for example. Additional securing systems that may be utilized include set screws, band straps, or snap rings, for example.

[60] The present invention is disclosed above and in the accompanying drawings with reference to a variety of embodiments. The purpose served by the disclosure, however, is to provide an example of the various features and concepts related to the invention, not to limit the scope of the invention. One skilled in the relevant art will recognize that numerous variations and modifications may be made to the embodiments described above without departing from the scope of the present invention, as defined by the appended claims.

69275-218

CLAIMS:

1. A method for modifying a characteristic of a sole structure for an article of footwear, said method comprising steps of:

5 manufacturing at least one discrete, vertically-projecting, columnar element to include a substantially vertical void located on an interior of said columnar element;

forming a cavity with an upper surface and an opposite lower surface in said sole structure, said cavity extending through a lateral side and a medial side of said footwear to form a horizontal aperture through the sole structure;

10 locating said columnar element between said upper surface and said lower surface of said cavity;

providing a first insert and a second insert that are separate from said sole structure and configured to be removably-received by said void; and

15 supplying each of said first insert and said second insert with a first securing portion of a securing mechanism and supplying said sole structure with a corresponding second securing portion of said securing mechanism, said first securing portion being joinable with said second securing portion to secure one of said first insert and said second insert within said void.

20 2. The method of claim 1, further including a step of inserting one of said first insert and said second insert within said void to modify said characteristic of said sole structure.

3. The method of claim 1, further including a step of removing both said first insert and said second insert from said void to modify said characteristic of said sole structure.

25 4. The method of claim 1, further including a step of interchanging said first insert with said second insert to modify said characteristic of said sole structure.

69275-218

5. The method of claim 1, wherein the step of manufacturing includes forming an aperture through an outsole of said sole structure to provide access for said first insert and said second insert.

6. The method of claim 1, wherein the step of providing includes forming said first insert and said second insert to have different physical properties.

7. The method of claim 1, wherein the step of providing includes forming said first insert and said second insert from materials with different compressibilities.

8. The method of claim 1, further including a step of positioning said second securing portion in an aperture formed in a semi-rigid plate.

9. The method of claim 8, wherein the step of positioning includes locating said semi-rigid plate between said columnar element and an outsole.

10. A method for modifying a characteristic of a sole structure for an article of footwear, said method comprising steps of:

manufacturing at least one discrete, vertically-projecting, columnar element to include an exterior surface and a substantially vertical void located on an interior of said columnar element;

forming a cavity with an upper surface and an opposite lower surface in said sole structure, said cavity extending through a lateral side and a medial side of said footwear to form a horizontal aperture through the sole structure;

locating said columnar element between said upper surface and said lower surface of said cavity such that said exterior surface is exposed within said cavity;

providing a first insert and a second insert that are separate from said sole structure and configured to be removably-received by said void, said first insert and said second insert being formed to have different physical properties;

69275-218

supplying each of said first insert and said second insert with a first securing portion of a securing mechanism and supplying said sole structure with a corresponding second securing portion of said securing mechanism, said first securing portion being joinable with said second securing portion to secure one of
 5 said first insert and said second insert within said void; and

selecting one of:

a first configuration, wherein said first insert is received by said void,

a second configuration, wherein said second insert is received by
 said void, and

10 a third configuration, wherein neither said first insert nor said second insert are received by said void.

11. The method of claim 10, wherein the step of manufacturing includes forming an aperture through an outsole of said sole structure to provide access for said first insert and said second insert.

15 12. The method of claim 10, wherein the step of providing includes selecting said different physical properties to be different compressibilities.

13. The method of claim 10, further including a step of positioning said second securing portion in an aperture formed in a semi-rigid plate.

14. The method of claim 13, wherein the step of positioning includes
 20 locating said semi-rigid plate between said columnar element and an outsole.

15. An article of footwear having an upper for receiving a foot of a wearer and a sole structure attached to said upper, said sole structure comprising:

a vertically-projecting, columnar element positioned between upper and lower surfaces of a cavity formed within said sole structure and having a
 25 substantially vertical void located on an interior of said columnar element, said cavity having an upper surface and an opposite lower surface, and said cavity extending through a lateral side and a medial side of said footwear to form a

69275-218

horizontal opening in said sole structure, said columnar element being positioned to extend between said upper surface and said lower surface; and

at least one insert dimensioned to be received by said void, said at least one insert including a first securing portion of a securing mechanism and
5 said sole structure including a corresponding second securing portion of said securing mechanism, said first securing portion joining with said second securing portion to secure said at least one insert within said void.

16. The article of footwear of claim 15, wherein removing said at least one insert from said void modifies a characteristic of said sole structure.

10 17. The article of footwear of claim 15, wherein said at least one insert includes a first insert and a second insert.

18. The article of footwear of claim 17, wherein said first insert is formed of a first material and said second insert is formed of a second material, said first material and said second material having different physical properties.

15 19. The article of footwear of claim 17, wherein removing said first insert from said void and inserting said second insert into said void modifies a characteristic of said sole structure.

20 20. The article of footwear of claim 15, wherein a wall thickness of said columnar is selected to support an individual when said at least one insert is removed from said void.

21. The article of footwear of claim 15, wherein a wall thickness of said columnar is insufficient to support an individual when said at least one insert is removed from said void.

25 22. The article of footwear of claim 15, wherein said columnar element is formed of a material that is at least semi-transparent.

69275-218

23. The article of footwear of claim 15, wherein one of said first securing portion and said second securing portion is a protrusion, and another of said first securing portion and said second securing portion includes a receptacle that is configured to receive said protrusion to secure said at least one insert within said void.

5 24. The article of footwear of claim 15, wherein said at least one insert includes an indentation for receiving a removal device that assists in a removal of said at least one insert from said void.

25. The article of footwear of claim 15, wherein a semi-rigid bottom plate is positioned below said cavity.

10 26. The article of footwear of claim 25, wherein said bottom plate includes an aperture aligned with said void for providing access to said void.

27. The article of footwear of claim 26, wherein said second securing portion is located in said aperture of said bottom plate.

15 28. The article of footwear of claim 15, wherein an outsole is positioned on a lower portion of said sole structure, said outsole including an aperture aligned with said void for providing access to said void.

29. The article of footwear of claim 28, wherein said outsole includes a cap that is removably-received by said aperture.

20 30. The article of footwear of claim 15, wherein said at least one insert and said void have a generally cylindrical configuration.

31. An article of footwear having an upper for receiving a foot of a wearer and a sole structure attached to said upper, said sole structure comprising:

25 a plurality of vertically-projecting, columnar elements extending between an upper surface and a lower surface of a cavity that is formed in a heel portion of said sole structure, said columnar elements including a first columnar element having a substantially vertical void located on an interior of said first columnar element, and said cavity extending through a lateral side and a medial side of said footwear to form a horizontal aperture through said sole structure;

69275-218

a first insert formed of a first material and located within said void, said first insert including a first securing portion of a securing mechanism, and said sole structure including a corresponding second securing portion of said securing mechanism, said first securing portion being joined with said second securing portion to releasably-secure said first insert within said void; and

a second insert formed of a second material and positioned outside of said void, said second insert being dimensioned to be received by said void upon removal of said first insert.

32. The article of footwear of claim 31, wherein removing said first insert from said void modifies a characteristic of said sole structure.

33. The article of footwear of claim 31, wherein removing said first insert from said void and inserting said second insert into said void modifies a characteristic of said sole structure.

34. The article of footwear of claim 31, wherein said first material and said second material have different physical properties such that interchanging said first insert with said second insert modifies a characteristic of said sole structure.

35. The article of footwear of claim 31, wherein one of said first securing portion and said second securing portion is a protrusion, and another of said first securing portion and said second securing portion includes a receptacle that is configured to receive said protrusion to secure said first insert within said void.

36. The article of footwear of claim 31, wherein said first insert includes an indentation for receiving a removal device that assists in a removal of said first insert from said void.

37. The article of footwear of claim 31, wherein said cavity is formed between a semi-rigid top plate and a semi-rigid bottom plate, said columnar element being positioned between said top plate and said bottom plate.

69275-218

38. The article of footwear of claim 37, wherein said bottom plate includes an aperture aligned with said void for providing access to said void.

39. The article of footwear of claim 38, wherein said second securing portion is located on said aperture of said bottom plate.

5 40. The article of footwear of claim 31, wherein an outsole is positioned on a lower portion of said sole structure, said outsole including an aperture aligned with said void for providing access to said void.

41. The article of footwear of claim 40, wherein said outsole includes a cap that is removably-received by said aperture.

10 42. The article of footwear of claim 31, wherein a wall thickness of said first columnar is selected to support an individual when said first insert or said second insert are removed from said void.

43. The article of footwear of claim 31, wherein a wall thickness of said first columnar is insufficient to support an individual when said first insert or said
15 second insert are removed from said void.

44. The article of footwear of claim 31, wherein said first columnar element is formed of a material that is at least semi-transparent.

45. An article of footwear having an upper for receiving a foot of a wearer and a sole structure attached to said upper, said sole structure comprising:

20 a plurality of discrete, vertically-projecting, columnar elements formed of a compressible material and located between upper and lower surfaces of a cavity within said sole structure, said columnar elements including a first columnar element with a substantially vertical void located on an interior of said first columnar element, and said cavity extending through a lateral side and a
25 medial side of said footwear to form a horizontal aperture through said sole structure;

69275-218

a first insert that is positioned within said void, said first insert including a first securing portion of a securing mechanism that joins with a corresponding securing portion of said securing mechanism to secure said first insert within said void; and

5 a plurality of second inserts that are located outside of said void, said second inserts each having a physical property that differs from a physical property of said first insert, said second inserts being interchangeable with said first insert to modify a characteristic of said sole structure, and said second inserts each including a second securing portion of said securing mechanism, said
10 second securing portion being joinable with said corresponding securing portion to secure one of said second inserts within said void.

46. The article of footwear of claim 45, wherein one of said first securing portion and said corresponding securing portion is a protrusion, and another of said first securing portion and said corresponding securing portion includes a
15 receptacle that is configured to receive said protrusion to secure said first insert within said void.

47. The article of footwear of claim 45, wherein said cavity is formed between a semi-rigid top plate and a semi-rigid bottom plate, said columnar element being positioned between said top plate and said bottom plate.

20 48. The article of footwear of claim 47, wherein said corresponding securing portion is located on an aperture of said bottom plate.

49. The article of footwear of claim 45, wherein a wall thickness of said first columnar is selected to support an individual when said first insert or one of said second inserts are removed from said void.

25 50. The article of footwear of claim 45, wherein a wall thickness of said first columnar is insufficient to support an individual when said first insert or one of said second inserts are removed from said void.

51. The article of footwear of claim 45, wherein said first columnar element is formed of a material that is at least semi-transparent.

69275-218

52. The article of footwear of claim 45, wherein an outsole is positioned on a lower portion of said sole structure, said outsole including an aperture aligned with said void for providing access to said void.

53. An article of footwear having an upper for receiving a foot of a
5 wearer and a sole structure attached to said upper, said sole structure comprising:

a midsole having a cavity located within a heel portion of said footwear, said midsole including a plurality of discrete, vertically-projecting, columnar elements formed of a compressible material and located within said cavity, said columnar elements extending between upper and lower portions of
10 said cavity to provide support for the foot, and said columnar elements including a first columnar element with a substantially vertical void located on an interior of said first columnar element, and said cavity extending through a lateral side and a medial side of said footwear to form a horizontal aperture through said sole structure;

15 an outsole attached to at least a portion of a lower surface of said midsole, said outsole including an aperture that provides access to said void;

a first insert that is separate from said sole structure, said first insert being dimensioned to extend through said aperture and into said void, said first insert including a first securing portion of a securing mechanism and said sole
20 structure including a corresponding securing portion of said securing mechanism, said first securing portion joining with said corresponding securing portion to secure said first insert within said void; and

a plurality of second inserts that are separate from said sole structure, said second inserts each having a physical property that differs from a
25 physical property of said first insert, said second inserts being dimensioned to extend through said aperture and into said void, said second inserts being interchangeable with said first insert to modify a characteristic of said sole structure, and said second inserts including a second portion of said securing mechanism, said second portion joining with said corresponding securing portion
30 to secure one of said second inserts within said void.

69275-218

54. The article of footwear of claim 53, wherein said first columnar element is located in a rear-lateral corner of said sole structure, and said columnar elements further include:

5 a second columnar element located in a rear-medial corner of said sole structure;

a third columnar element located forward of said first columnar element; and

a fourth columnar element located forward of said second columnar element,

10 wherein each of said second, said third, and said fourth columnar elements include voids that receive third inserts, said third inserts being interchangeable with said second inserts to modify a stiffness of said sole structure.

55. The article of footwear of claim 53, wherein said cavity is formed
15 between a semi-rigid top plate and a semi-rigid bottom plate, said columnar element being positioned between said top plate and said bottom plate.

56. The article of footwear of claim 55, wherein said bottom plate includes an aperture that provides access to said void.

57. The article of footwear of claim 56, wherein said corresponding
20 securing portion is located on said aperture of said bottom plate.

58. The article of footwear of claim 53, wherein said void and said first insert each have a generally cylindrical configuration.

59. An article of footwear having an upper for receiving a foot of a
wearer and a sole structure attached to said upper, said sole structure comprising:

25 a discrete, vertically-projecting, columnar element positioned between upper and lower surfaces of a cavity formed within said sole structure and having a substantially vertical void located on an interior of said columnar element;

69275-218

an outsole positioned to form a lower surface of said sole structure, said outsole forming an outsole aperture located below said void;

a plate formed of a semi-rigid material and positioned between said columnar element and said outsole, said plate forming a plate aperture located
5 below said void; and

at least one insert dimensioned to be received by said void, said at least one insert including a first securing portion of a securing mechanism and said plate aperture including a corresponding second securing portion of said securing mechanism, said first securing portion joining with said second securing
10 portion to secure said at least one insert within said void.

60. The article of footwear of claim 59, wherein removing said at least one insert from said void modifies a characteristic of said sole structure.

61. The article of footwear of claim 59, wherein said at least one insert includes a first insert and a second insert.

15 62. The article of footwear of claim 61, wherein said first insert is formed of a first material and said second insert is formed of a second material, said first material and said second material having different physical properties.

63. The article of footwear of claim 61, wherein removing said first insert from said void and inserting said second insert into said void modifies a
20 characteristic of said sole structure.

64. The article of footwear of claim 59, wherein one of said first securing portion and said second securing portion is a protrusion, and another of said first securing portion and said second securing portion includes a receptacle that is configured to receive said protrusion to secure said at least one insert within said
25 void.

65. The article of footwear of claim 59, wherein said at least one insert includes an indentation for receiving a removal device that assists in a removal of said at least one insert from said void.

69275-218

66. The article of footwear of claim 59, wherein said at least one insert and said void have a generally cylindrical configuration.

67. An article of footwear having an upper for receiving a foot of a wearer and a sole structure attached to said upper, said sole structure comprising:

5 a plurality of discrete, vertically-projecting, columnar elements formed of a compressible material and located between upper and lower surfaces of a cavity within said sole structure, said columnar elements including a first columnar element with a substantially vertical void located on an interior of said first columnar element, and said cavity extending through a lateral side and a medial side of said
10 footwear to form a horizontal aperture through said sole structure;

a plate formed of a semi-rigid material positioned below said columnar elements, said plate defining an aperture that is aligned with said void to provide access to said void;

15 a first insert that is positioned within said void, said first insert including a first securing portion of a securing mechanism that joins with a corresponding securing portion of said securing mechanism to secure said first insert within said void, said corresponding securing portion being located in said aperture; and

20 a plurality of second inserts that are located outside of said void, said second inserts each having a physical property that differs from a physical property of said first insert, said second inserts being interchangeable with said first insert to modify a characteristic of said sole structure, and said second inserts each including a second securing portion of said securing mechanism, said second securing portion being joinable with said corresponding securing portion to secure one of said second inserts within said void.

25 68. The article of footwear of claim 67, wherein one of said first securing portion and said corresponding securing portion is a protrusion, and another of said first securing portion and said corresponding securing portion includes a receptacle that is configured to receive said protrusion to secure said first insert within said void.

69275-218

69. The article of footwear of claim 67, wherein an outsole is positioned on a lower portion of said sole structure.

70. The article of footwear of claim 67, wherein a wall thickness of said first columnar is selected to support an individual when said first insert and said
5 second inserts are removed from said void.

71. The article of footwear of claim 67, wherein a wall thickness of said first columnar is insufficient to support an individual when said first insert and said second inserts are removed from said void.

72. The article of footwear of claim 67, wherein said first columnar
10 element is formed of a material that is at least semi-transparent.

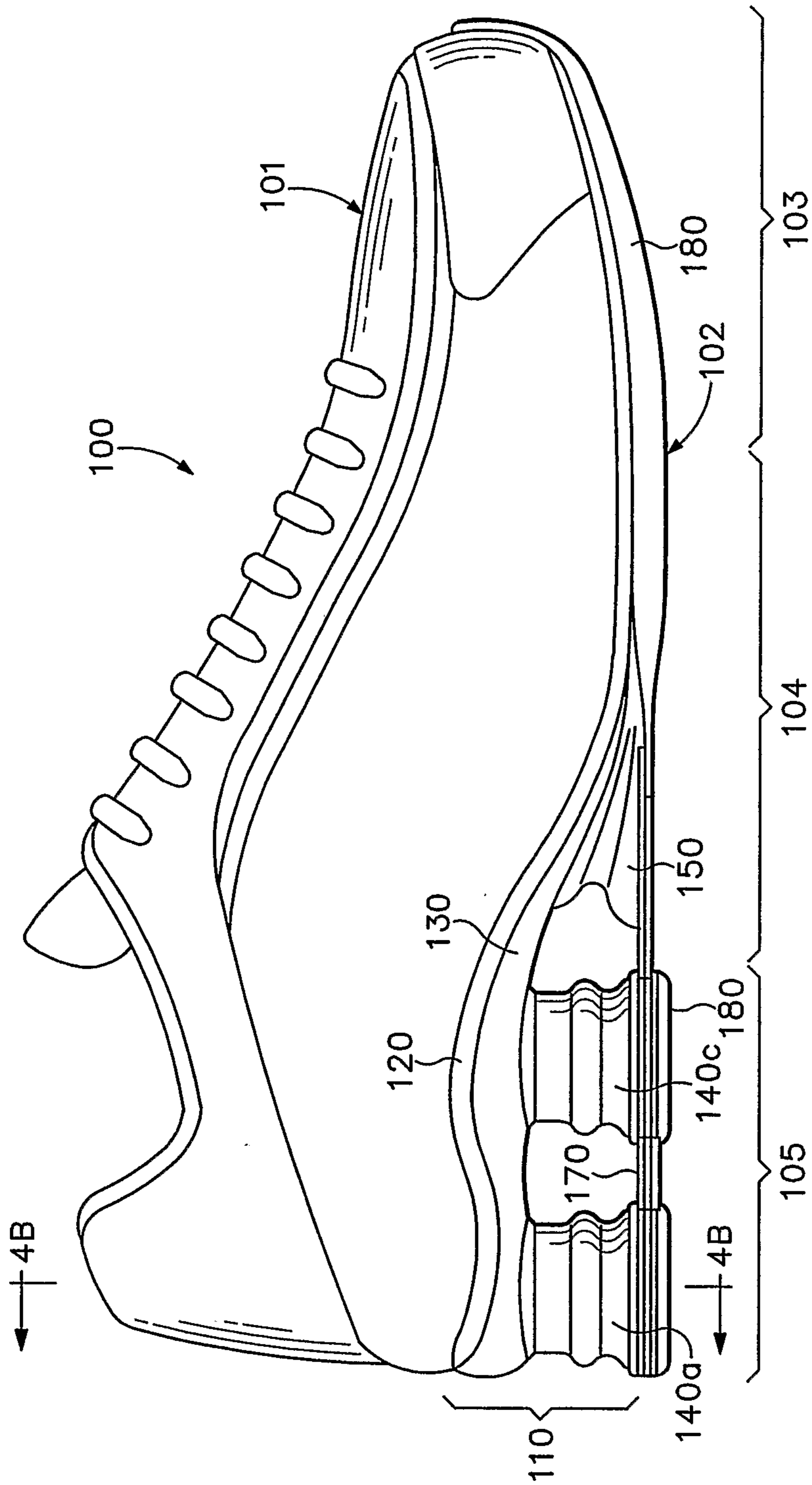

Figure 1

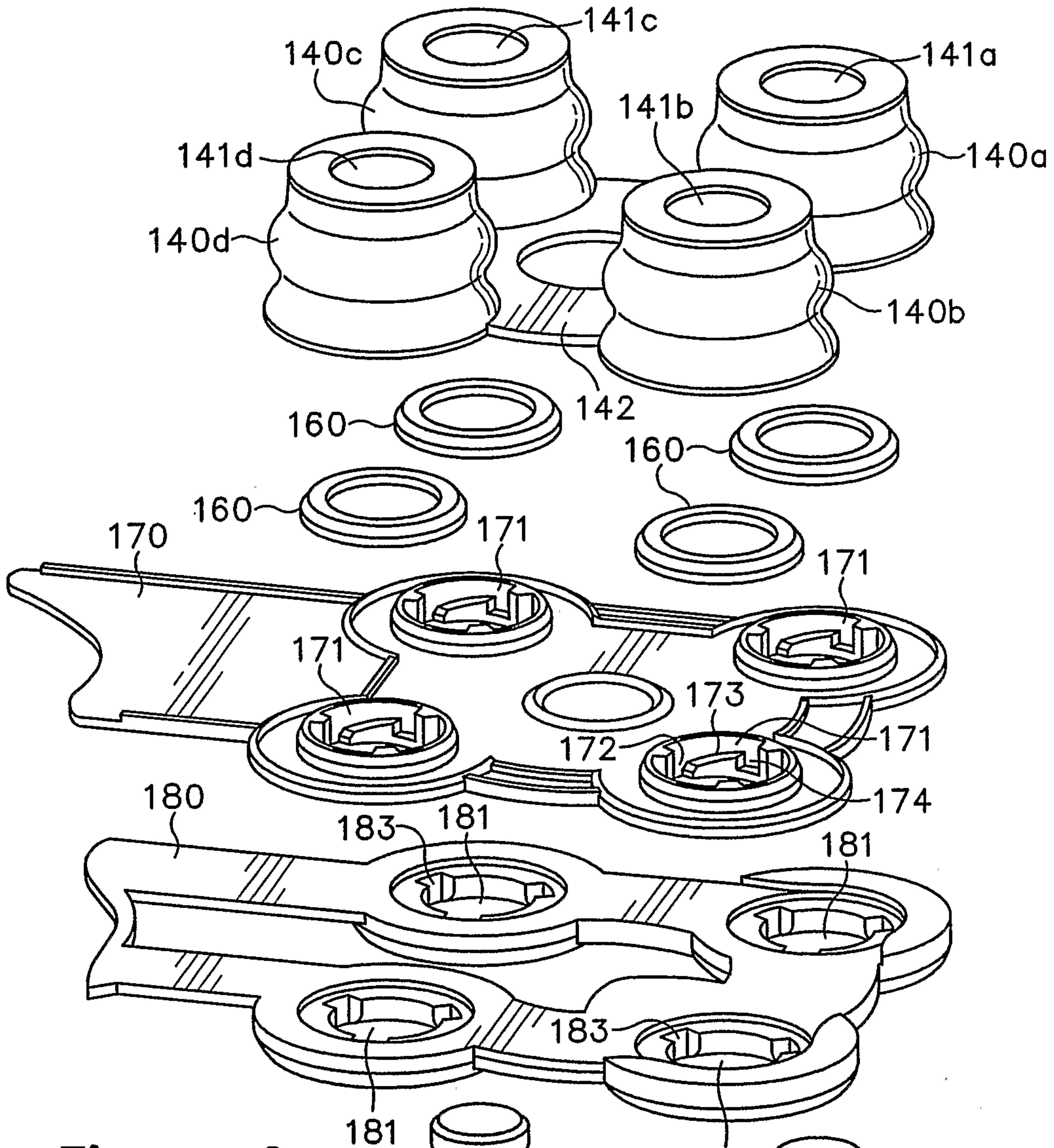
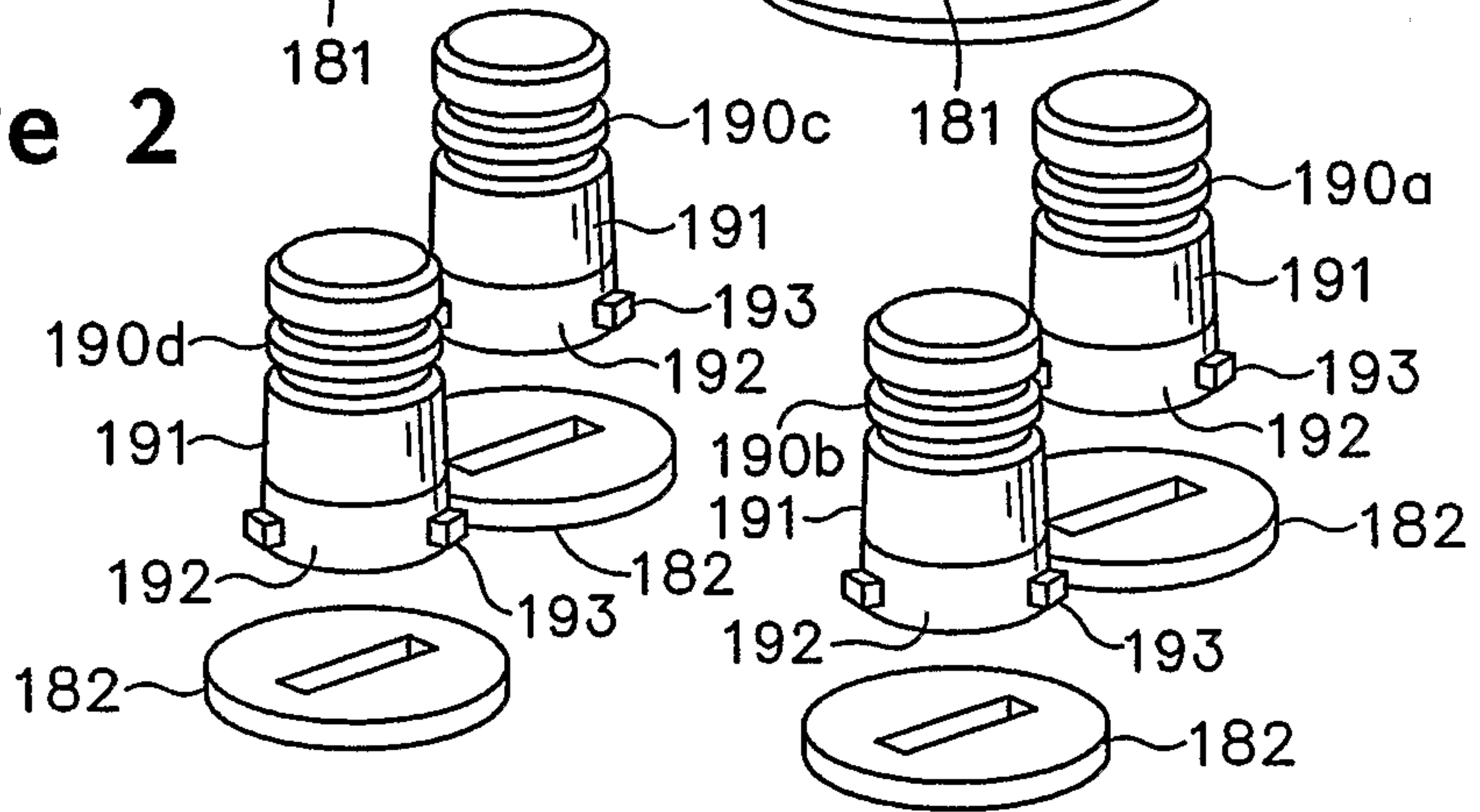

Figure 2



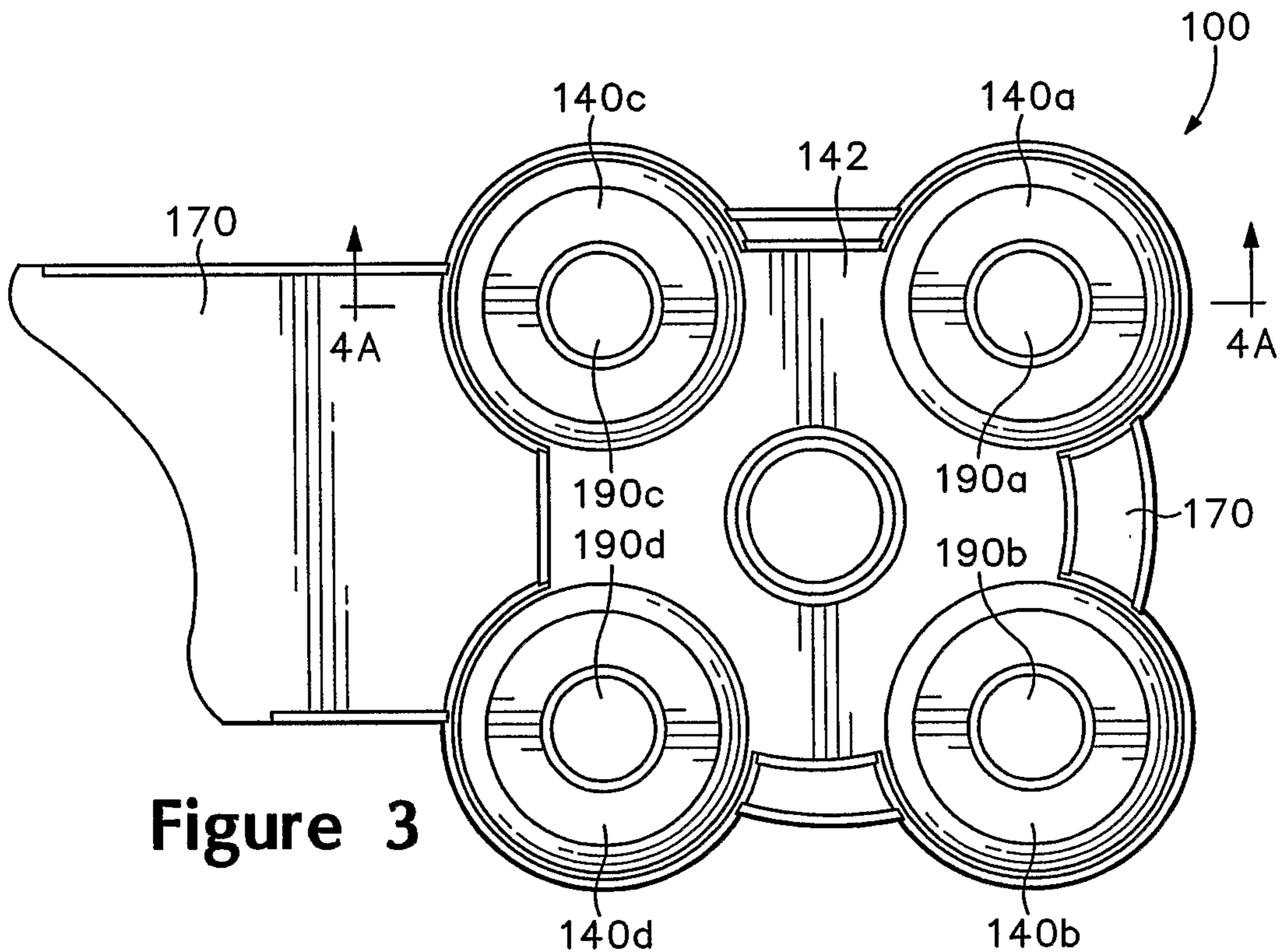

Figure 3

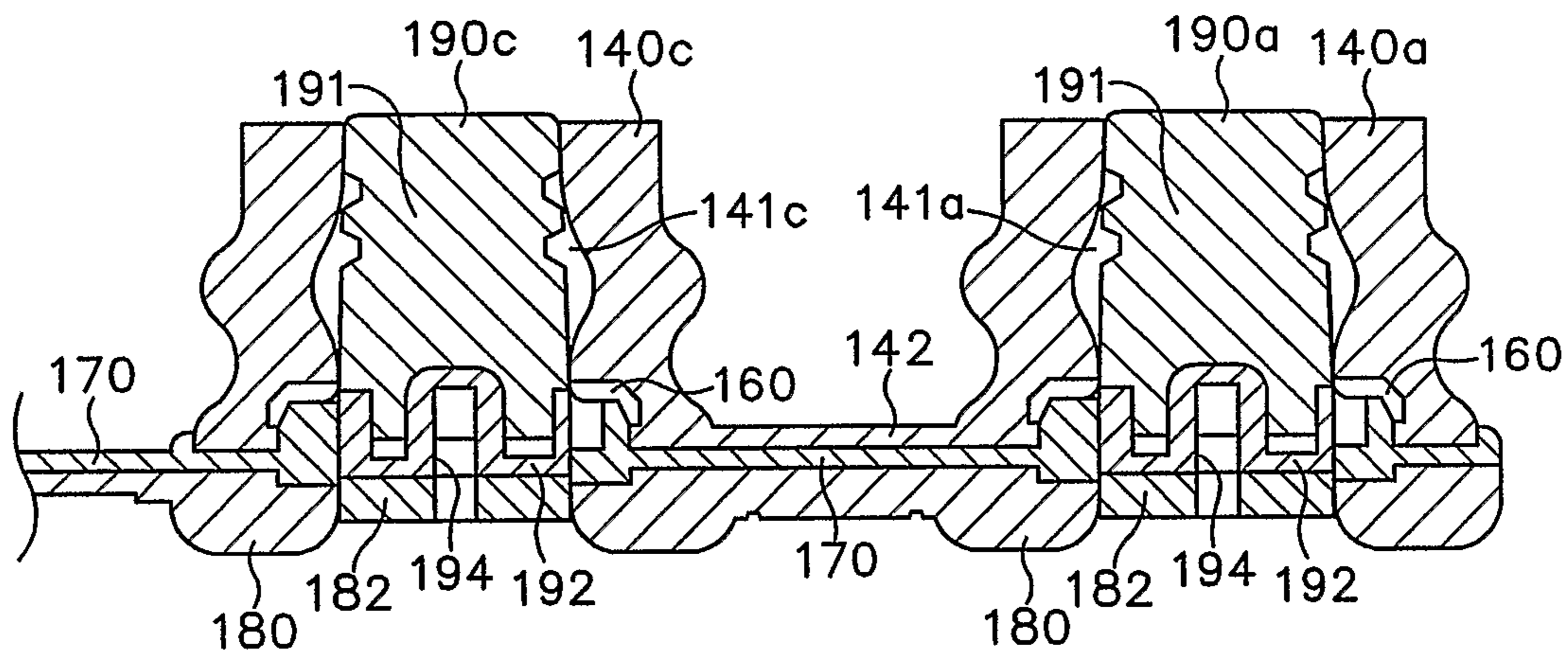

Figure 4A

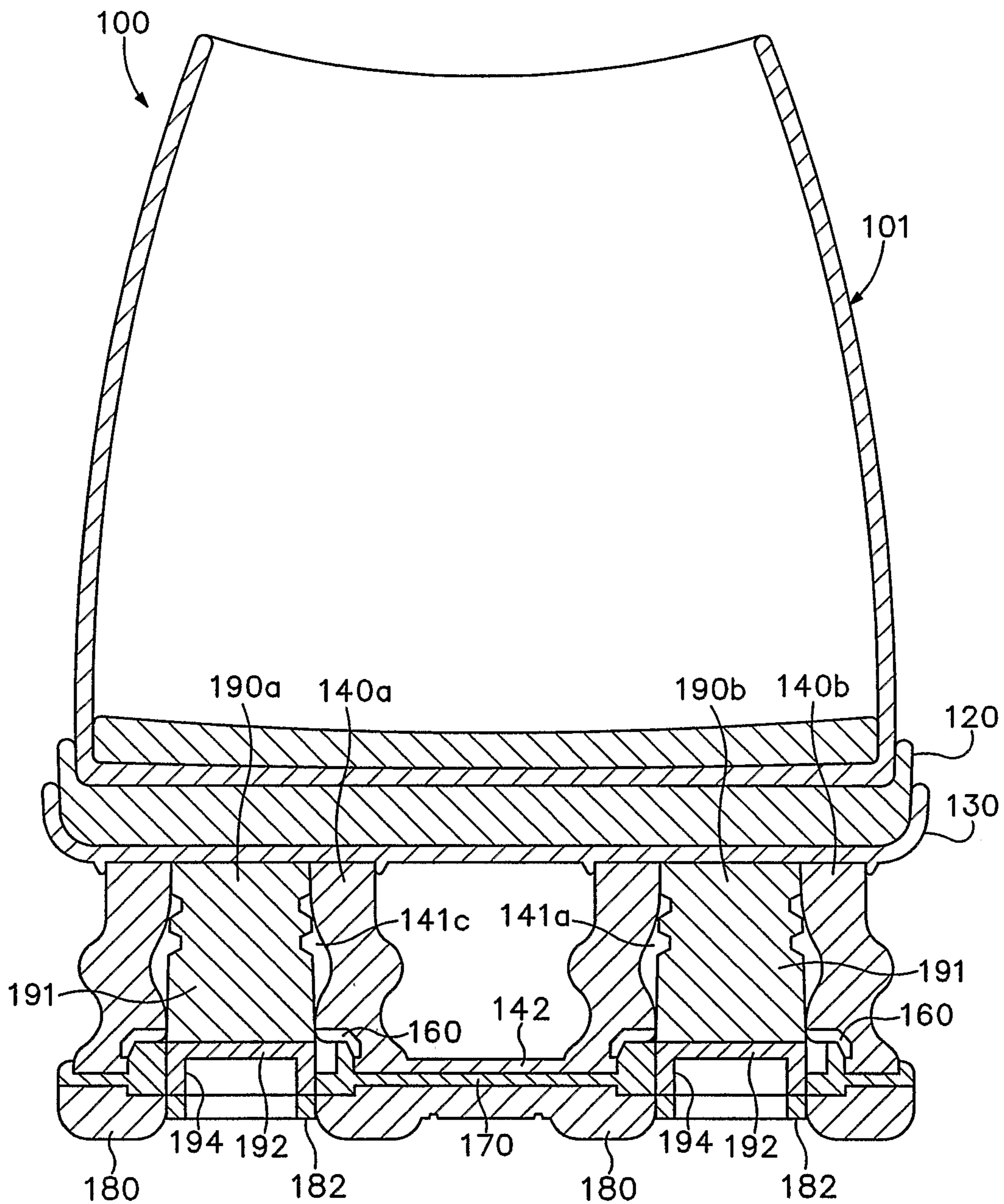

Figure 4B

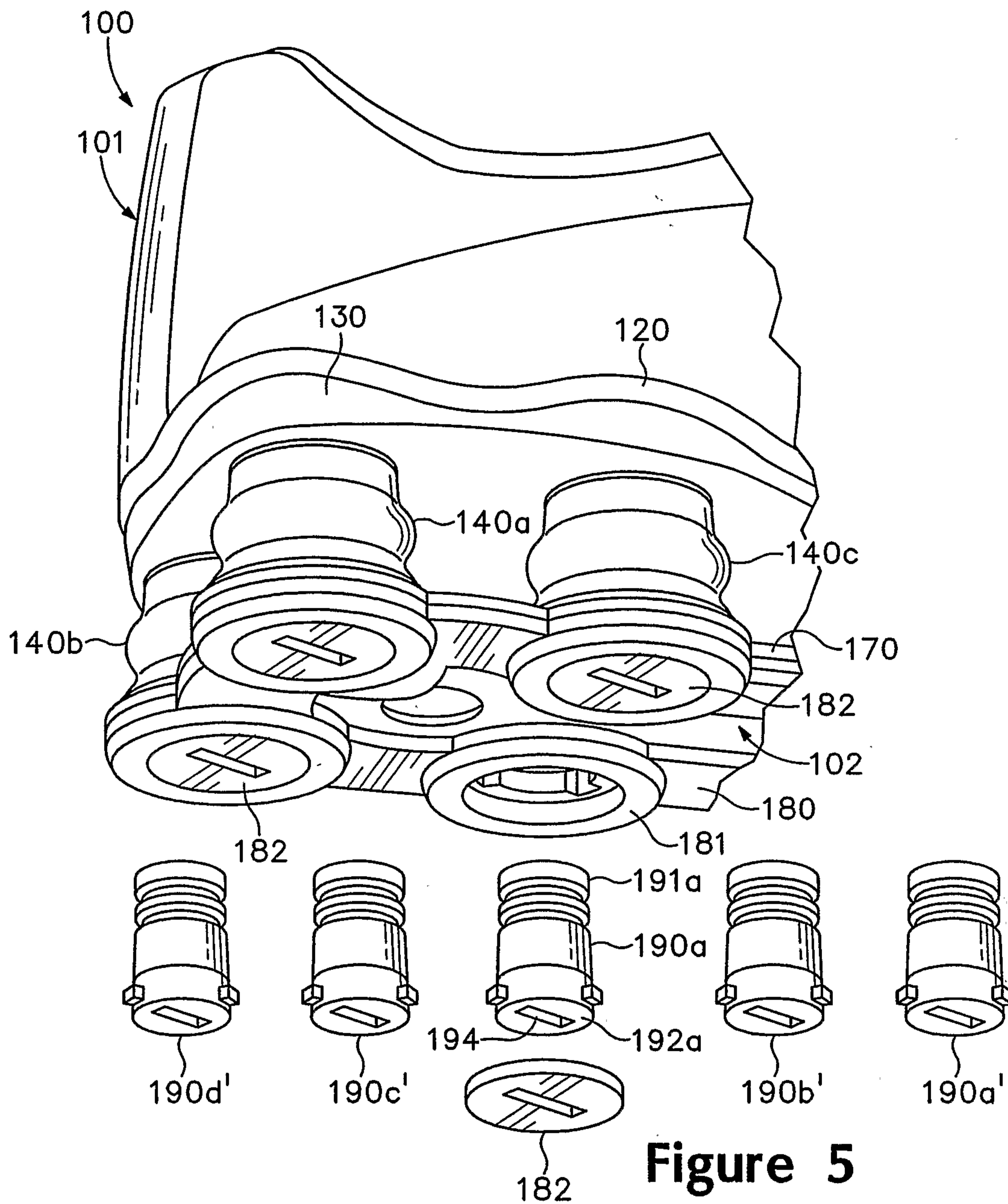

Figure 5

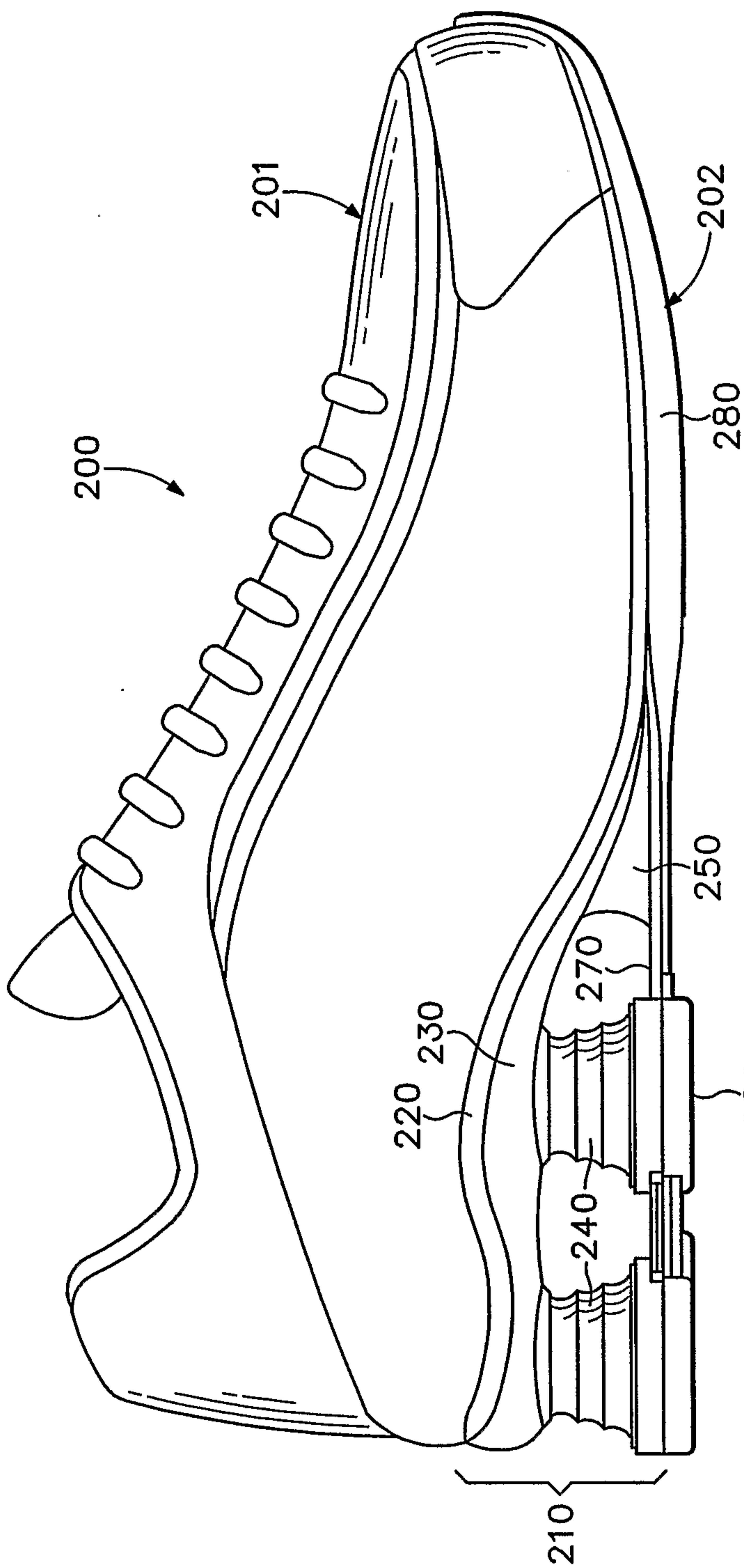

Figure 6

7/11

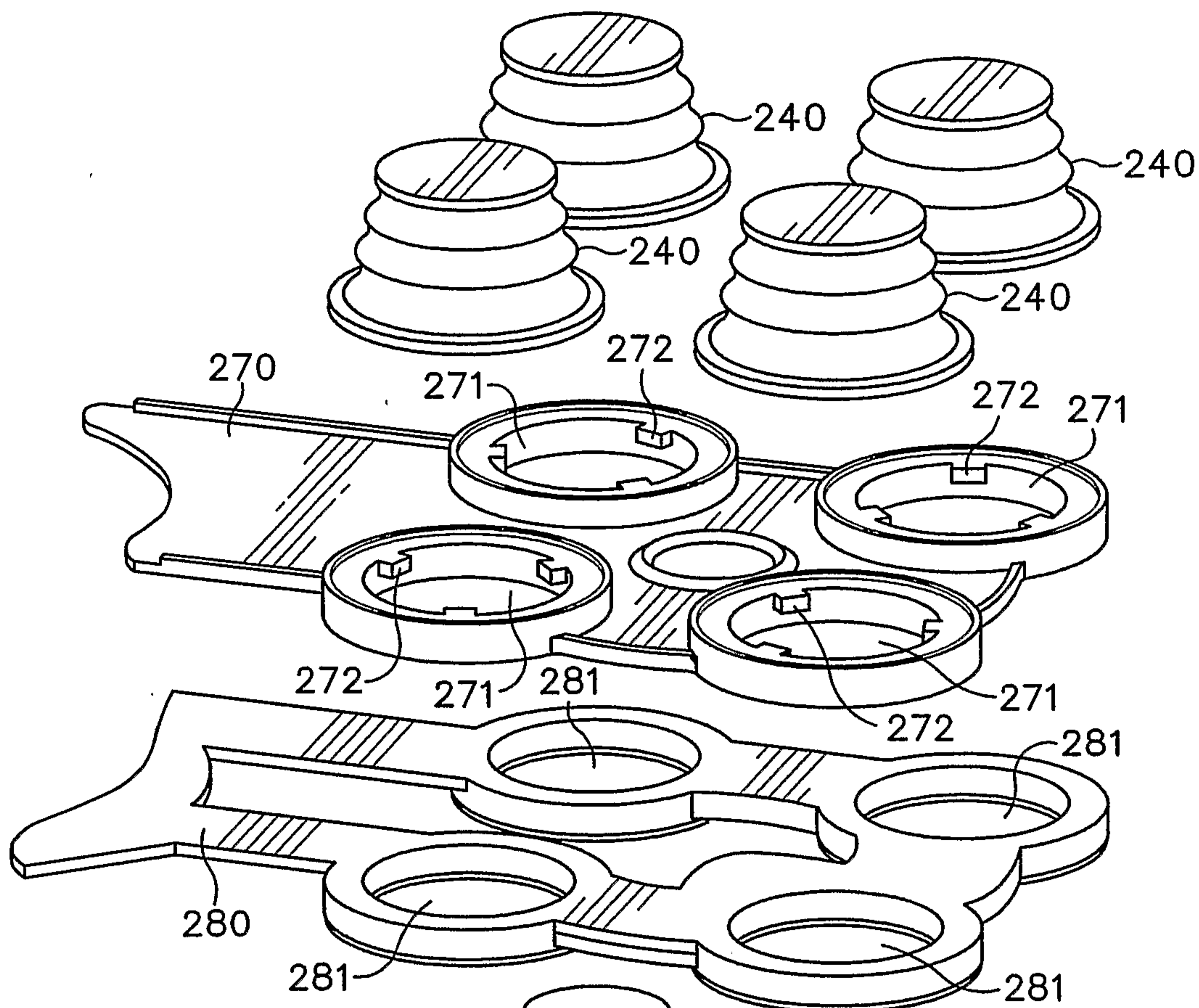
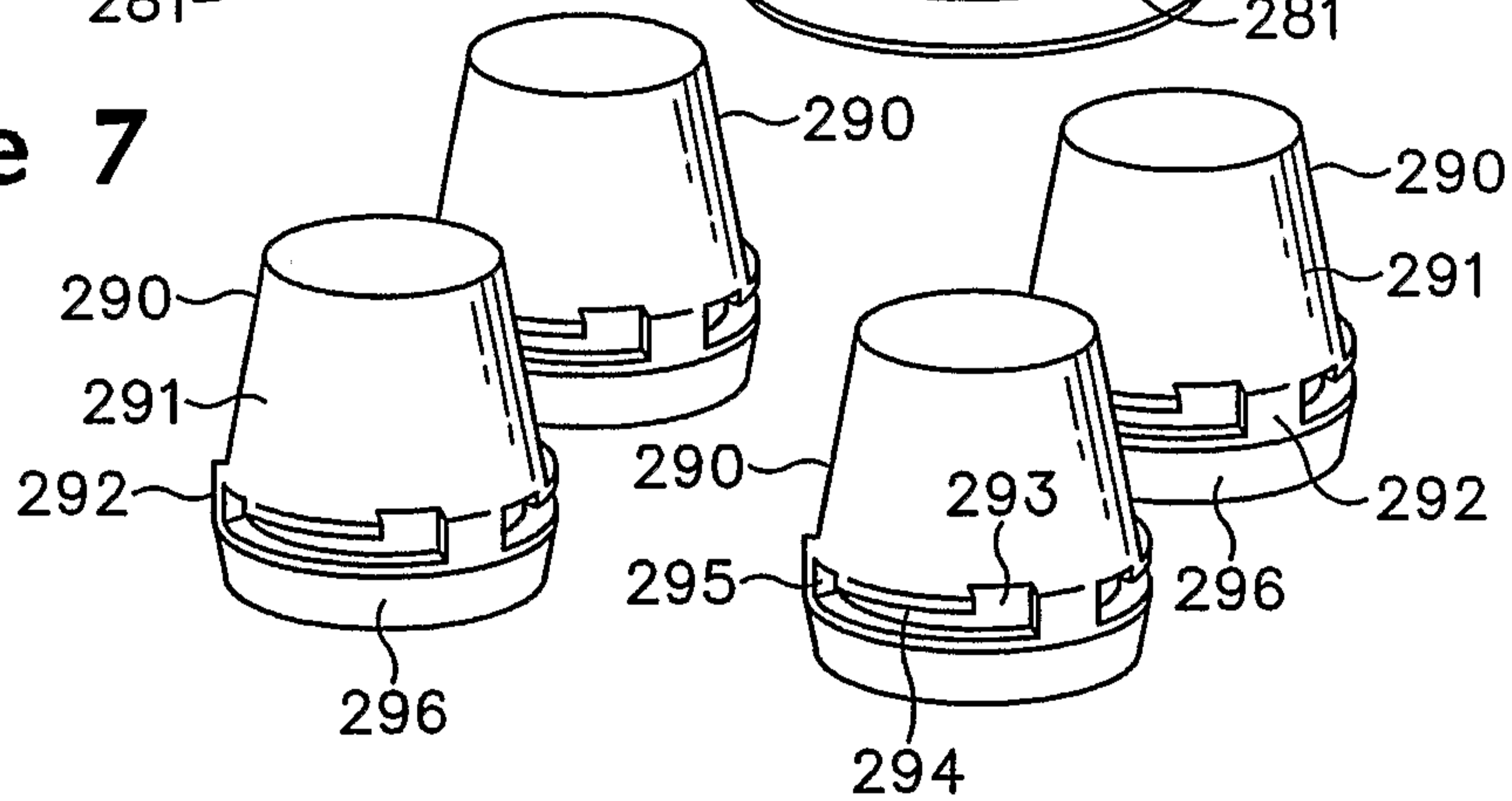

Figure 7



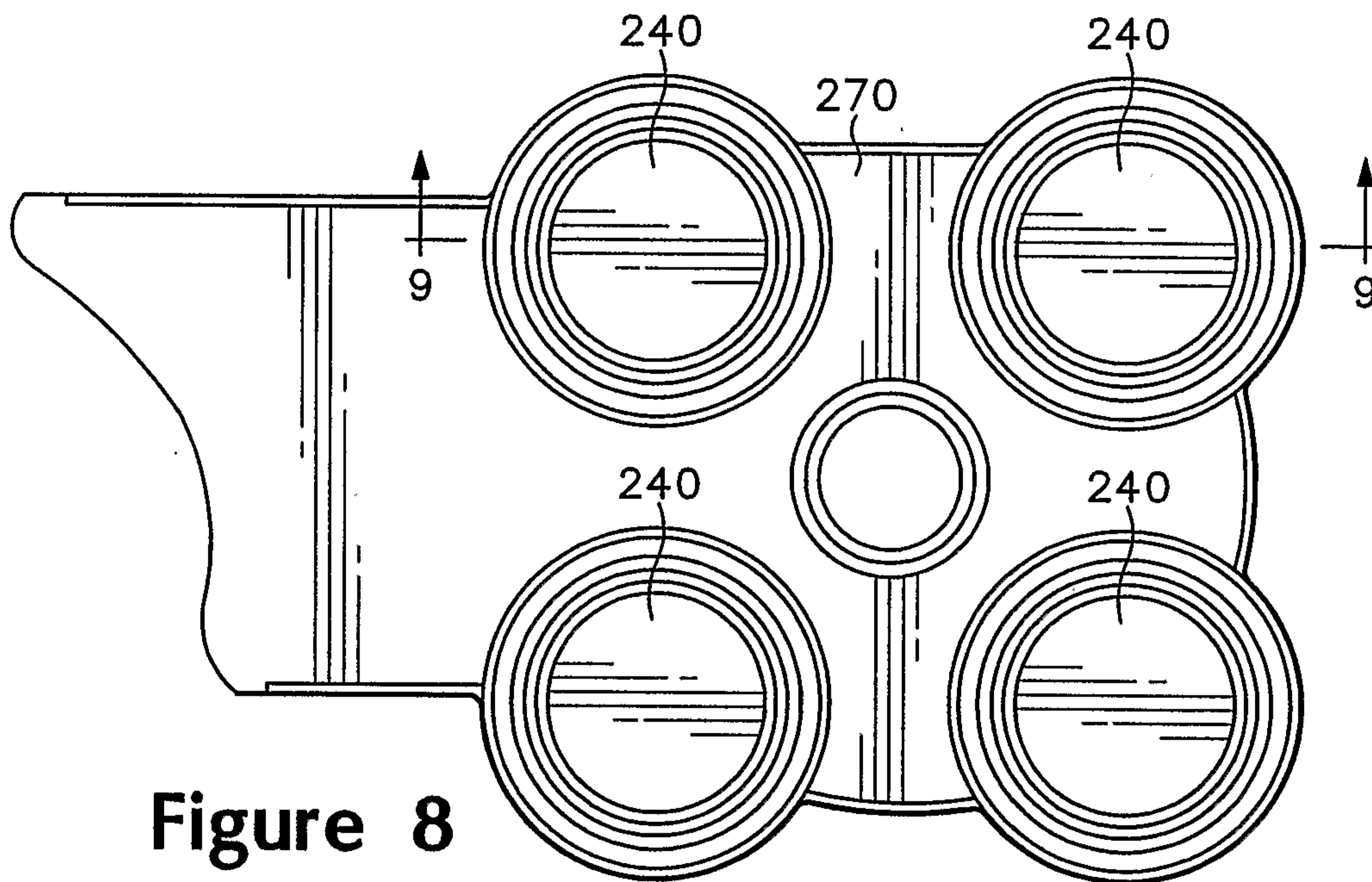

Figure 8

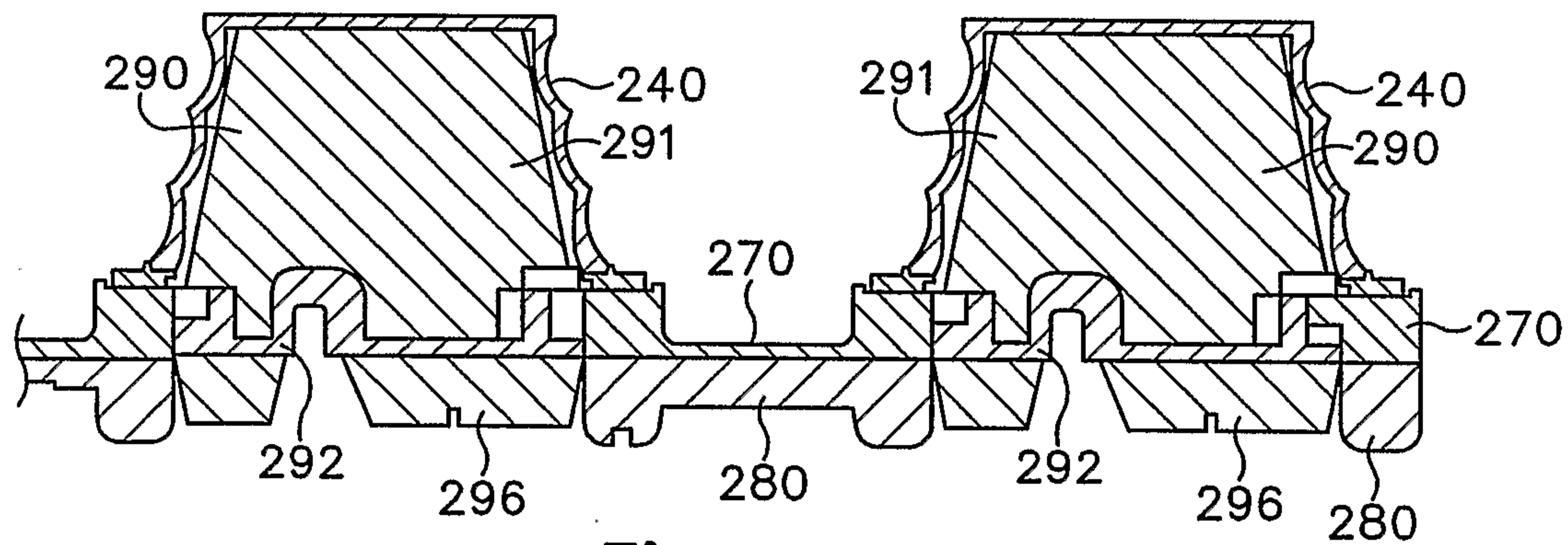

Figure 9

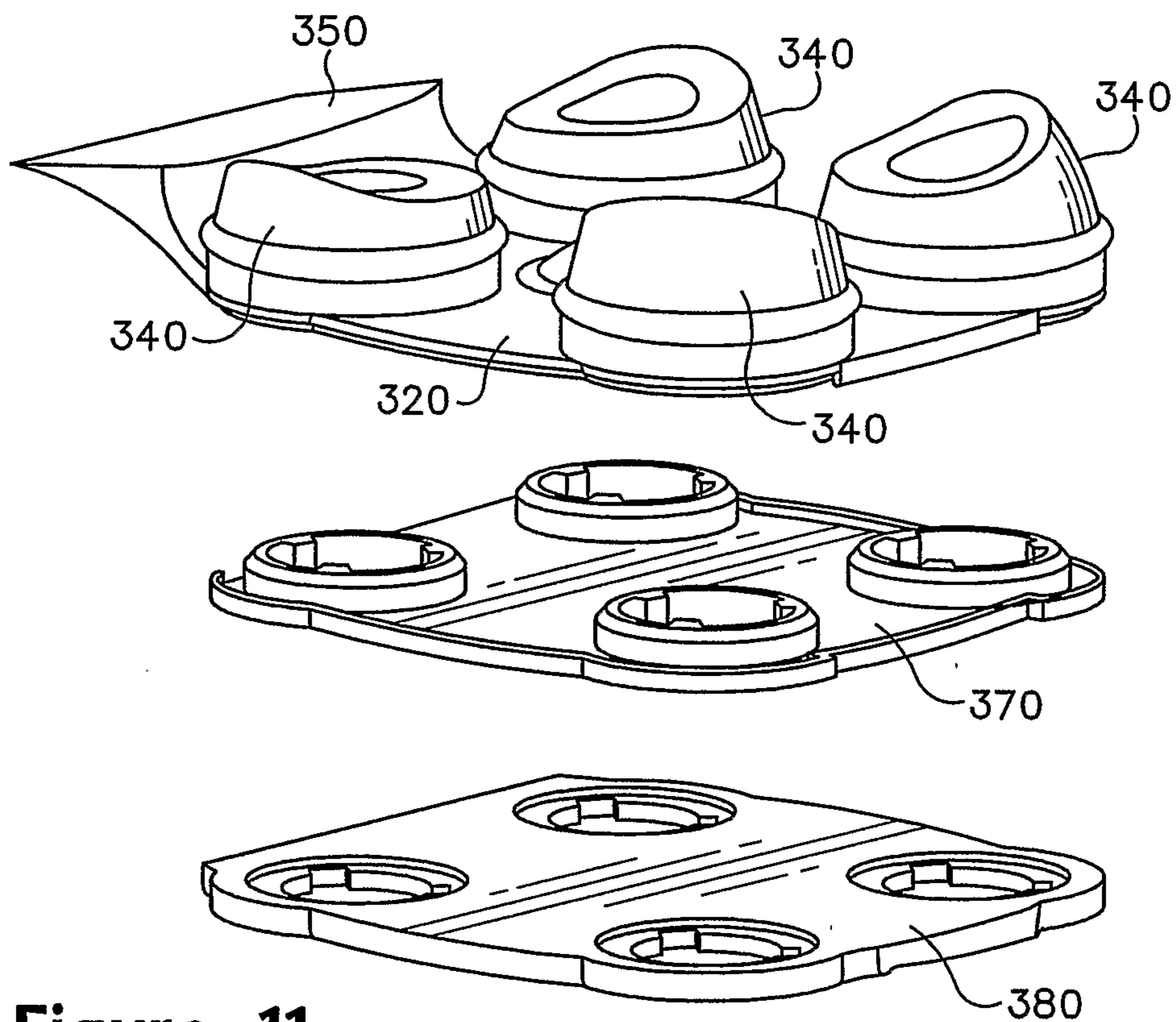
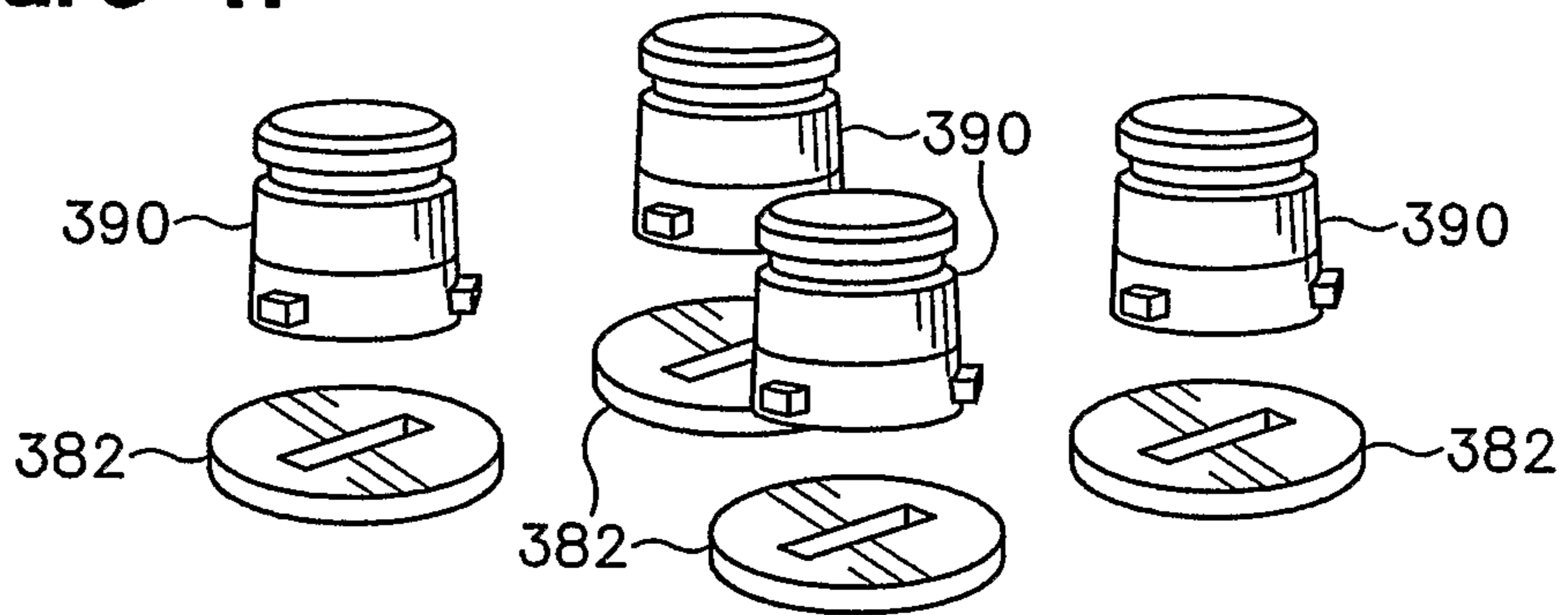

Figure 11



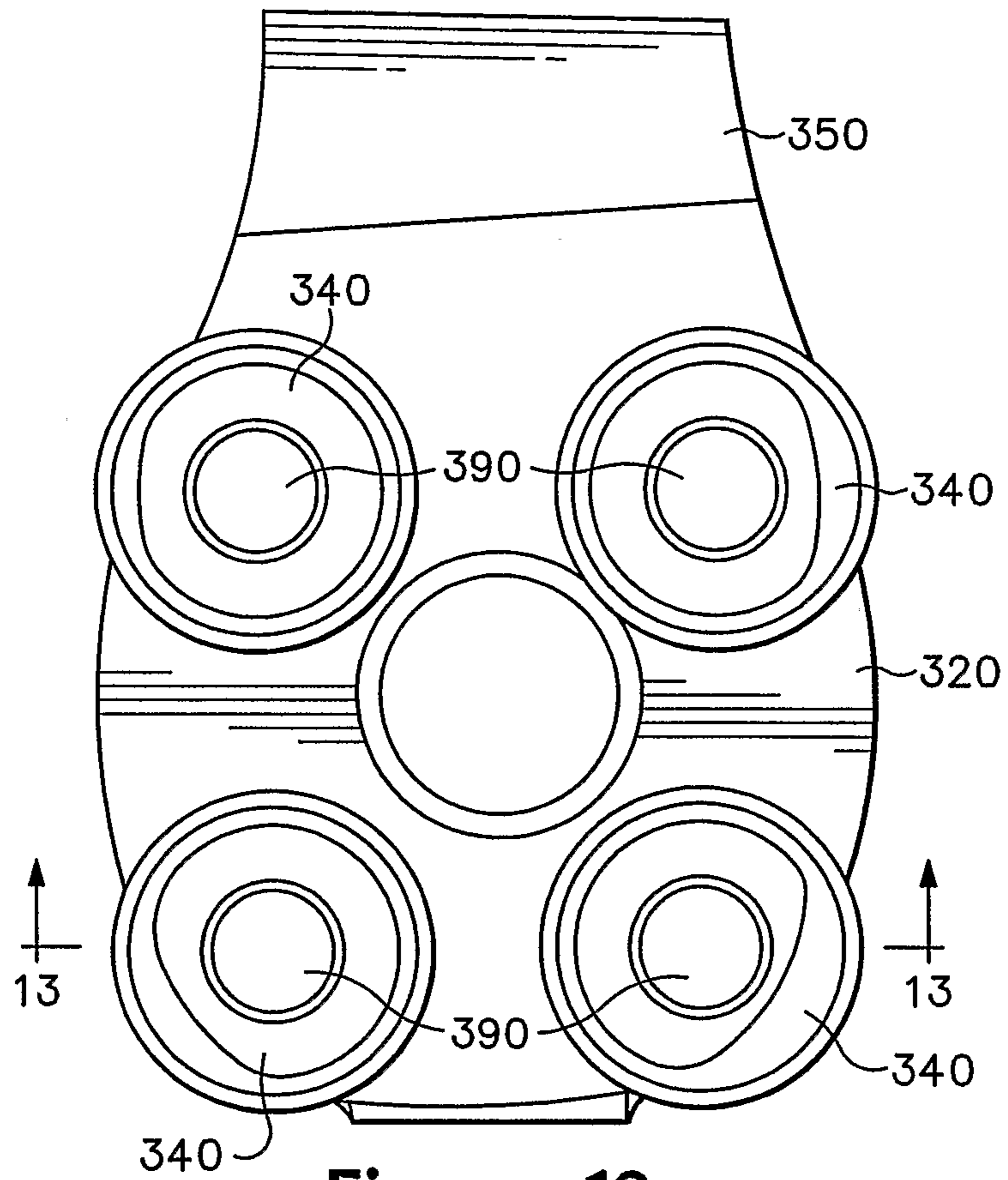

Figure 12

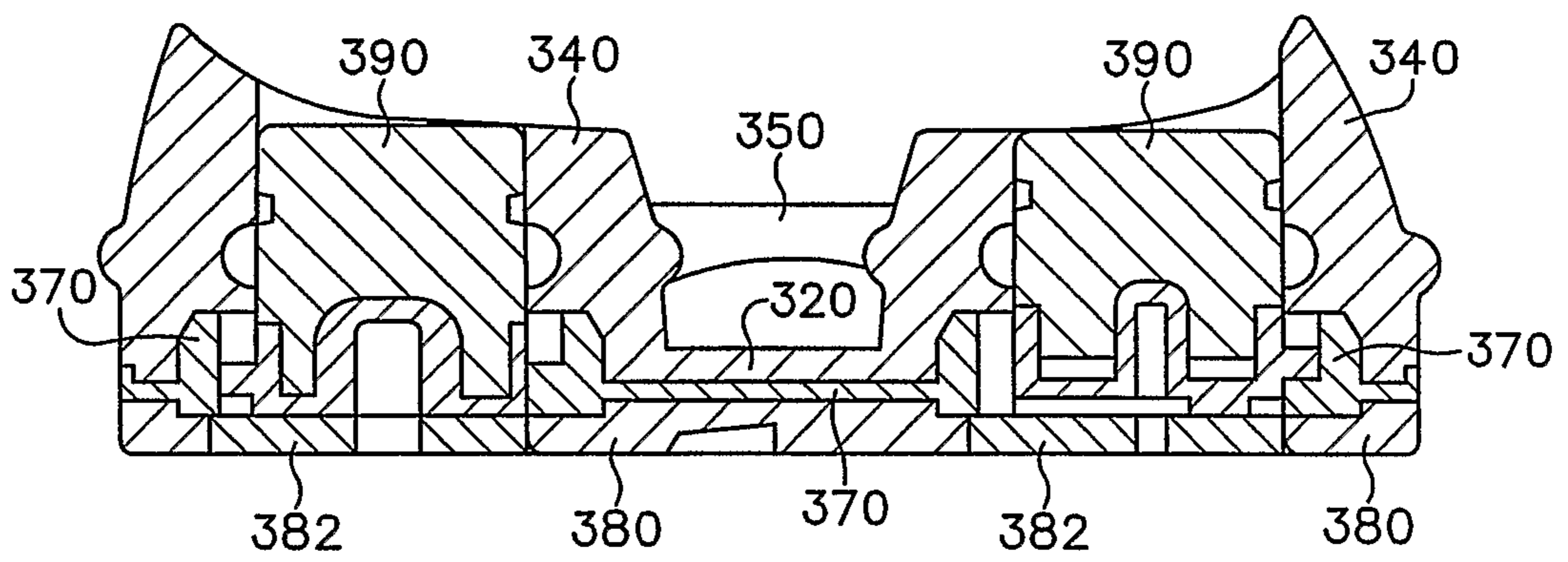

Figure 13

