

(12) INTERNATIONAL APPLICATION PUBLISHED UNDER THE PATENT COOPERATION TREATY (PCT)

(19) World Intellectual Property
Organization

International Bureau

(43) International Publication Date
01 August 2019 (01.08.2019)



(10) International Publication Number
WO 2019/147204 A2

(51) International Patent Classification:

Not classified

(21) International Application Number:

PCT/TR2018/050422

(22) International Filing Date:

08 August 2018 (08.08.2018)

(25) Filing Language:

Turkish

(26) Publication Language:

English

(30) Priority Data:

2017/20493 15 December 2017 (15.12.2017) TR

(71) Applicant: **SAMSUN YURT SAVUNMA SANAYI VE TICARET ANONIM SIRKET** [TR/TR]; Organize Sanayi Bolgesi Ulubatli Caddesi No:2, Tekkeköy/Samsun (TR).

(72) Inventor: **ARAL, Utku**; Organize Sanayi Bolgesi Ulubatli Caddesi No:2, Tekkeköy/Samsun (TR).

(74) Agent: **AKKAS, Ahmet**; Akademi Mh. Gurbulut Sk. Konya Teknokent Binasi No:F-212, Konya (TR).

(81) Designated States (unless otherwise indicated, for every kind of national protection available): AE, AG, AL, AM, AO, AT, AU, AZ, BA, BB, BG, BH, BN, BR, BW, BY, BZ, CA, CH, CL, CN, CO, CR, CU, CZ, DE, DJ, DK, DM, DO, DZ, EC, EE, EG, ES, FI, GB, GD, GE, GH, GM, GT, HN, HR, HU, ID, IL, IN, IR, IS, JO, JP, KE, KG, KH, KN, KP,

KR, KW, KZ, LA, LC, LK, LR, LS, LU, LY, MA, MD, ME, MG, MK, MN, MW, MX, MY, MZ, NA, NG, NI, NO, NZ, OM, PA, PE, PG, PH, PL, PT, QA, RO, RS, RU, RW, SA, SC, SD, SE, SG, SK, SL, SM, ST, SV, SY, TH, TJ, TM, TN, TR, TT, TZ, UA, UG, US, UZ, VC, VN, ZA, ZM, ZW.

(84) Designated States (unless otherwise indicated, for every kind of regional protection available): ARIPO (BW, GH, GM, KE, LR, LS, MW, MZ, NA, RW, SD, SL, ST, SZ, TZ, UG, ZM, ZW), Eurasian (AM, AZ, BY, KG, KZ, RU, TJ, TM), European (AL, AT, BE, BG, CH, CY, CZ, DE, DK, EE, ES, FI, FR, GB, GR, HR, HU, IE, IS, IT, LT, LU, LV, MC, MK, MT, NL, NO, PL, PT, RO, RS, SE, SI, SK, SM, TR), OAPI (BF, BJ, CF, CG, CI, CM, GA, GN, GQ, GW, KM, ML, MR, NE, SN, TD, TG).

Published:

— without international search report and to be republished upon receipt of that report (Rule 48.2(g))

(54) Title: A MAGAZINE LOCK

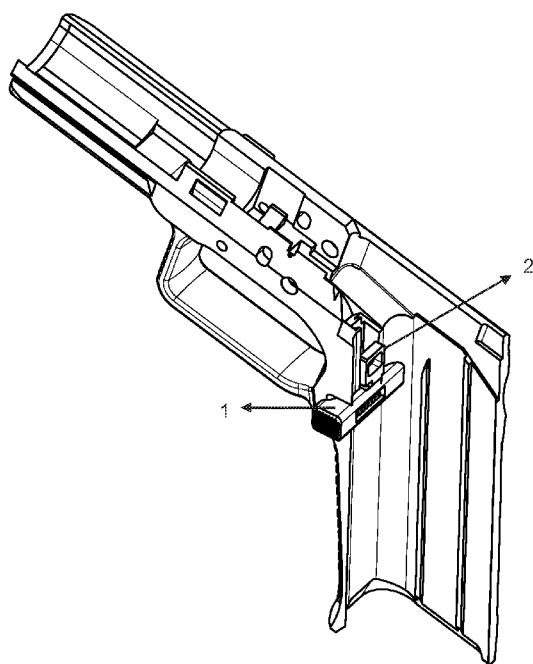

FIGURE 1

(57) Abstract: The invention relates to a magazine lock which is easily replaceable by users using different hands, which prevents the magazine from displacing during the fall and provides a more efficient locking with the special forms it contains.



WO 2019/147204 A2

A MAGAZINE LOCK

TECHNICAL FIELD

系 The invention relates to a magazine lock which is easily replaceable by users using different hands, which prevents the magazine from displacing during the fall and provides a more efficient locking with the special forms it contains.

BRIEF DESCRIPTION OF THE INVENTION

机 The invention is a snap-on system which allows users using different hands to easily change and use the magazine locks according to the desired side. This system makes it very simple to turn the magazine lock in the desired direction and to use it safely. A pin is also designed to hold the magazine lock in its place and to prevent it from letting the magazine free during the fall by being completely rest against the snap-on.

系

LIST OF FIGURES

Figure 1. Upper Left Cross Section view of the Magazine Lock mounted to the Gun

Figure 2. Mounted View of the Magazine Lock

机 Figure 3. Magazine Lock Assembly

Figure 4. Exploded View of the Magazine Lock

Equivalents of the numbers used in the figures are given below:

1. Lock Button
- 机 2. Magazine Catch Lock Switch
3. Spring
4. Spring Pin
5. Lock Housing

机 DETAILED DESCRIPTION OF THE INVENTION

The invention is a snap-on system which allows users using different hands to easily change and use a magazine lock according to the desired side. This system makes it very simple to turn the magazine lock in the desired direction and to use it safely. The magazine lock comprises a lock button (1) which further comprises a

knurled form that facilitates pressing on and prevents finger from slippage. That button also comprises a lock spring (3) which is guided by a spring pin (4) and works in the desired range. As seen in Figures 3 and Figure 4, the lock button (1) is fixed by the magazine catch lock switch (2) in its place and is guided in the lock housing (5).

系 The spring (3) and the spring pin (4) contained in the lock button (1) are first assembled to each other as shown in the exploded view in FIG 2. The magazine catch lock switch (2) is fixed by being passed through the lock button (1), which the spring (3) and the spring pin (4) is mounted on. It is also fixed by fitting the spring pin (4) on the groove of itself, which meets the form of the head part of the spring pin (4). A 系 special groove is made on the lock button (1) so that the magazine catch lock switch (2) can pass smoothly through the lock button (1). In addition, the spring pin (4) provides the magazine catch lock switch (2) to pass without distorting the spring (3). The fully assembled view is given in Fig 3.

系 For right-handed use, the lock button (1) is placed in the lock slot (5) so that the groove on it faces the right. By pushing the lock button (1) a little, the magazine catch lock switch (2) is passed from the end of the groove to the lock switch bed and pressed over to be fixed. The system becomes suitable for right hand use.

系 For left-handed use, the lock button (1) is placed in the lock slot (5) so that the groove on it faces the left. By pushing the lock button (1) a little, the magazine catch lock switch (2) is passed from the end of the groove to the lock switch bed and pressed over to be fixed. The system becomes suitable for left hand use.

系 When it is necessary to disassemble the magazine lock in order to use it in the desired direction; the magazine catch lock switch (2), which is positioned to be reached through the body when the upper lid of the gun is removed by pressing the lock button (1), is pulled up from the lock switch bed on the magazine lock. The magazine lock is easily removed from the lock housing (5) since it's no longer fixed by the magazine catch lock switch (2).

系 In order to prevent the magazine lock from getting loose from the magazine catch lock switch (2) in case of a possible fall, there is a groove as shown on the magazine catch lock switch (2) in Fig 2. The spring (3) and the spring pin (4) sit on that groove. Thus, the magazine catch lock switch (2) is fixed by the spring (3) and the spring pin (4). The magazine catch lock switch (2) is designed as a tie hook to take precautions to get rid of it easily.

In the upper part of the magazine catch lock switch (2), a rectangle discharge is made so that it is less affected by the high accelerations due to the fall, and it can be easily removed with the tools like a screwdriver.

系

机

系

机

机

机

CLAIMS

1. A lock magazine characterized in that, comprising a lock button (1), a magazine catch lock switch (2), a spring (3), a spring pin (4) and a lock housing (5).
- 系 2. The lock button (1) of Claim 1 is characterized in that, comprising a knurled form that facilitates pressing on and prevents finger from slippage.
3. The lock button (1) of Claim 1 is characterized in that, comprising a groove on it so that the magazine catch lock switch (2) can pass smoothly through the lock button (1).
- 机 4. The magazine catch lock switch (2) of Claim 2 is characterized in that, comprising a groove in order to prevent the magazine lock from getting loose in case of a possible fall in which the spring (3) and the spring pin (4) sit.
4. The magazine catch lock switch (2) of Claim 4 is characterized in that, by being designed as a tie hook to take precautions to get rid of it easily from its place.
- 系 5. The magazine catch lock switch (2) of Claim 5 is characterized in that, comprising a rectangle discharge in the upper part of it so that it is less affected by the high accelerations due to the fall, and it can be easily removed with the tools like a screwdriver.

机

机

机

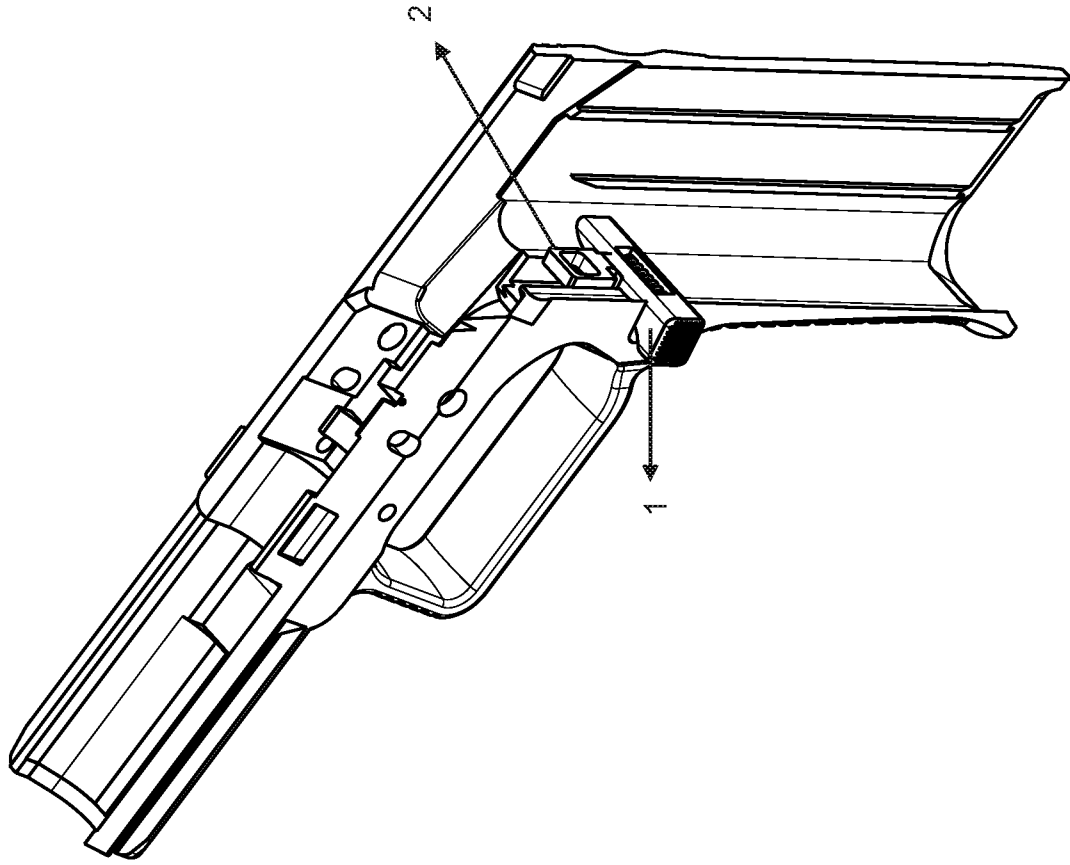

FIGURE 1

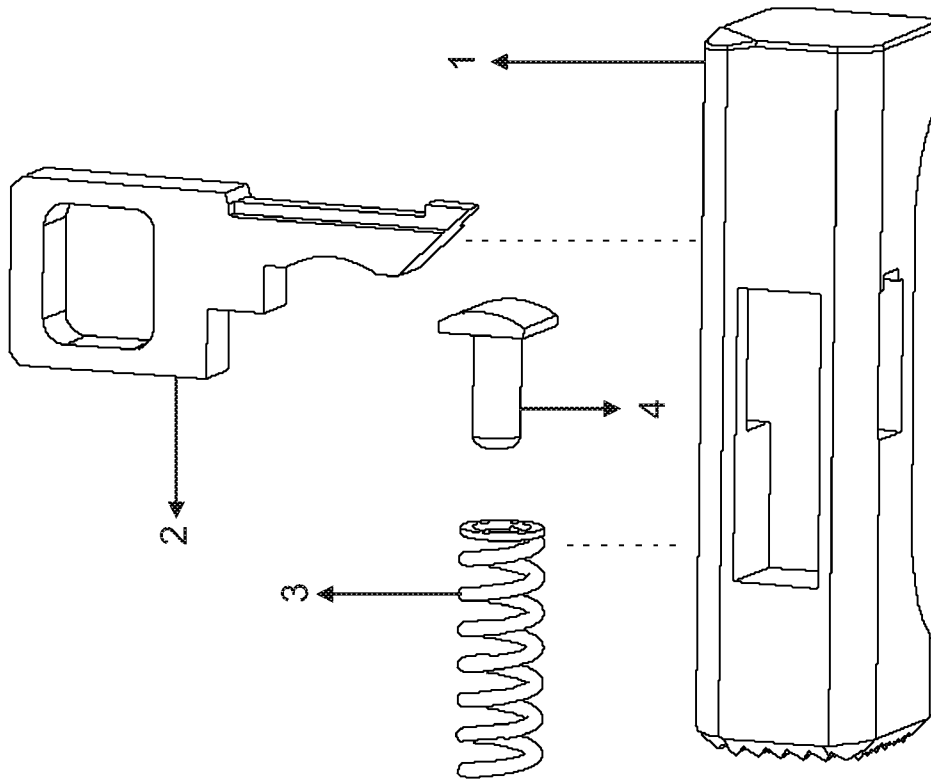

FIGURE 2

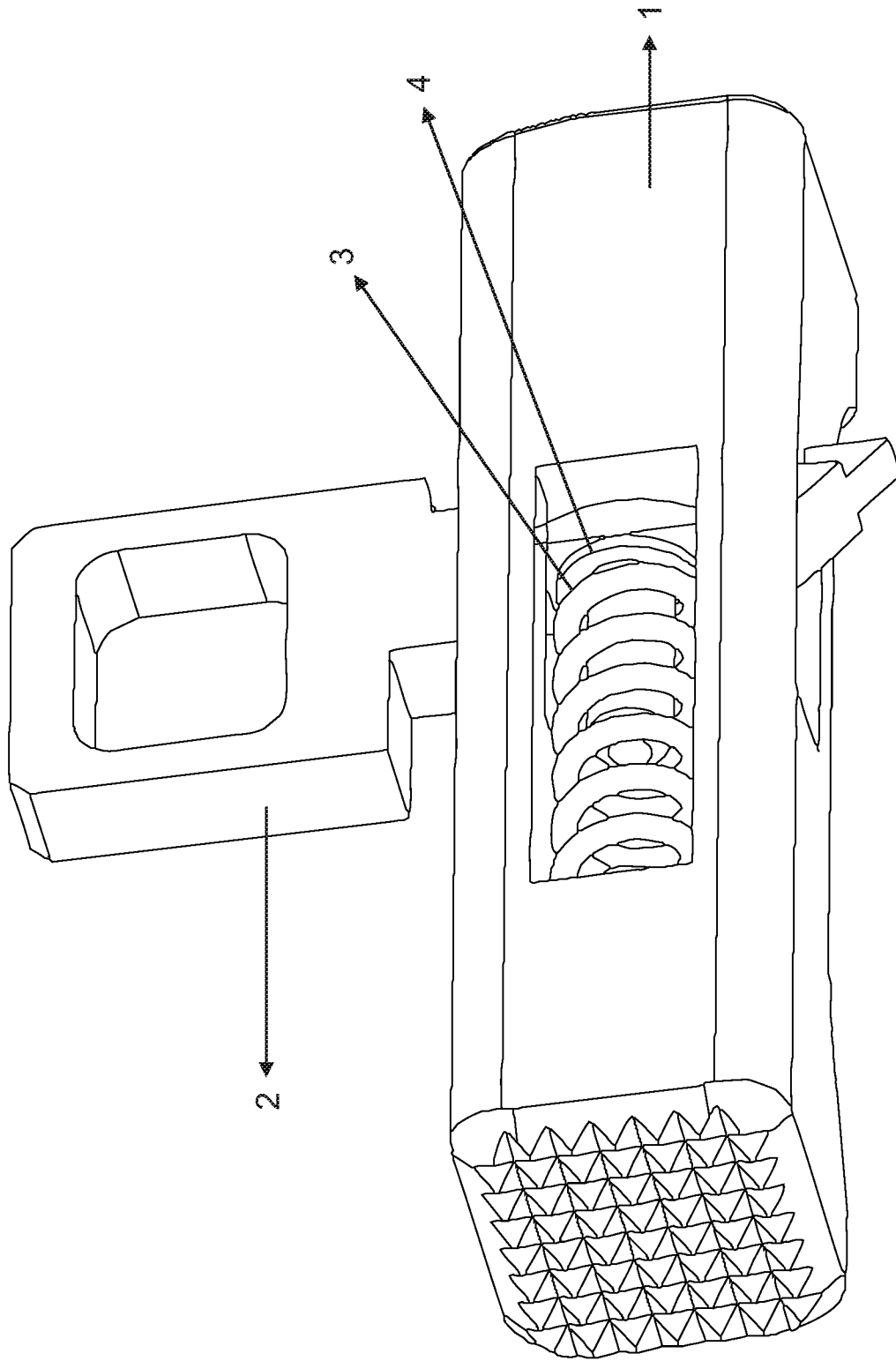

FIGURE 3

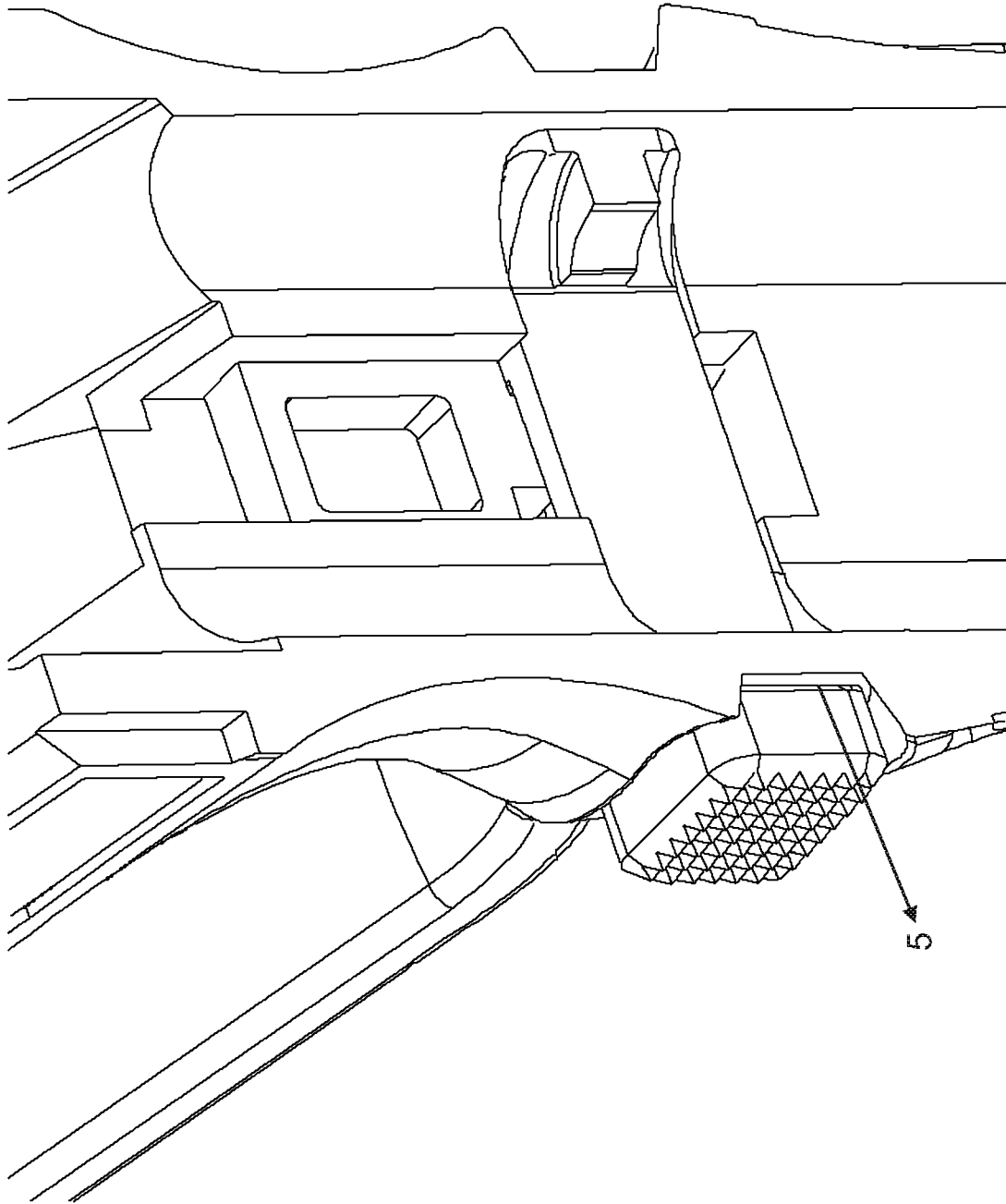

FIGURE 4