

(No Model.)

2 Sheets—Sheet 1.

E. THOMSON.

COMMUTATOR FOR DYNAMO ELECTRIC MACHINES.

No. 523,019.

Patented July 17, 1894.

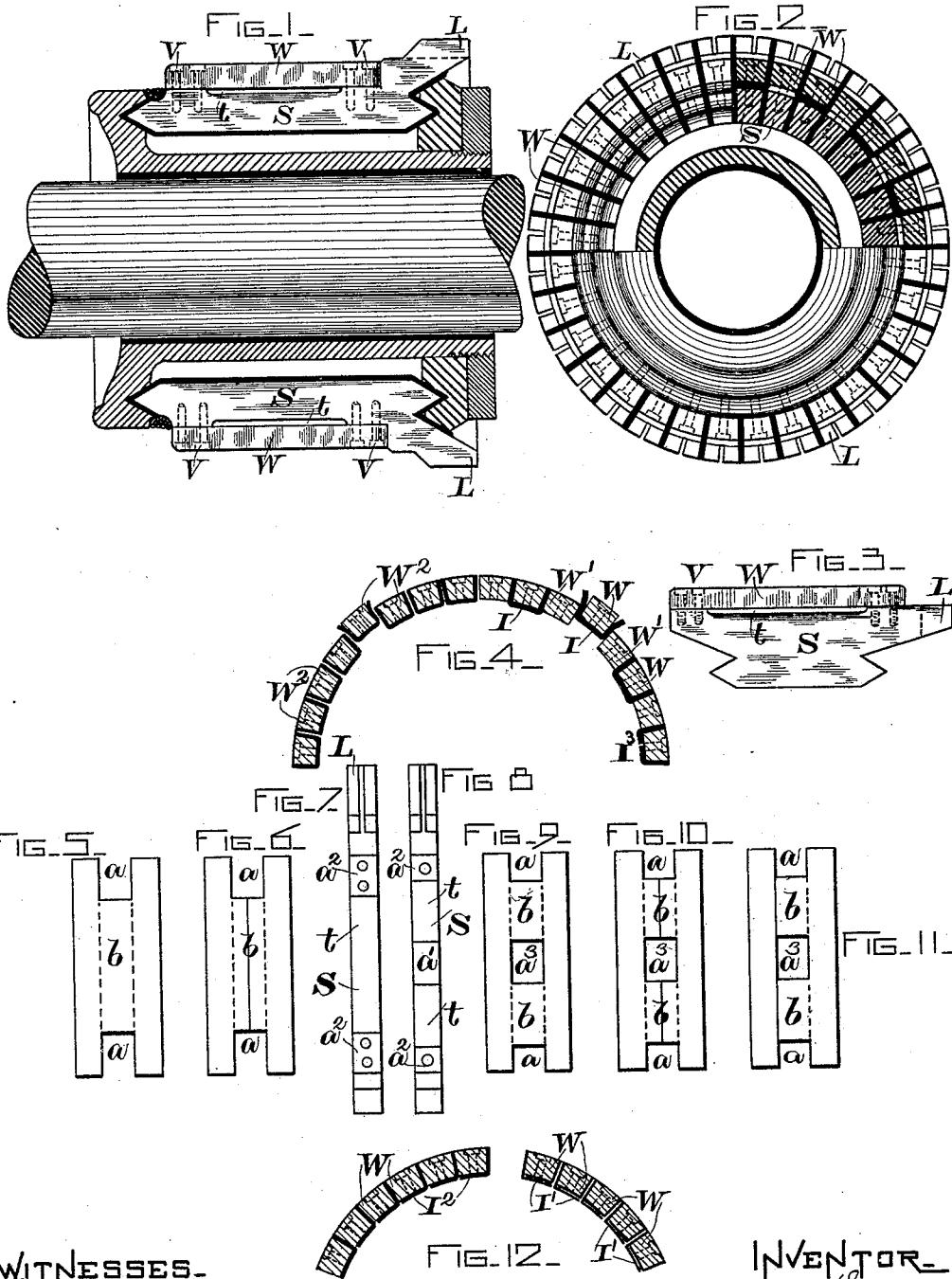

WITNESSES.
Kenny Westendampf.
E. Thomson.

INVENTOR—
Edwin Thomson, by
Bentley and Woodgett,
 attys.

(No Model.)

2 Sheets—Sheet 2.

E. THOMSON.

COMMUTATOR FOR DYNAMO ELECTRIC MACHINES.

No. 523,019.

Patented July 17, 1894.

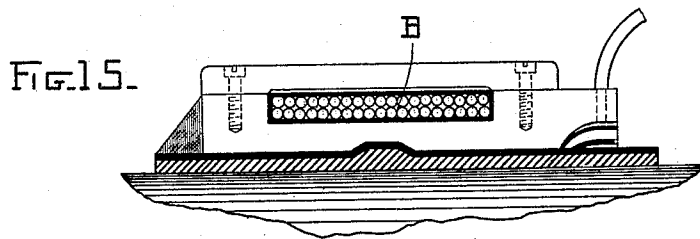
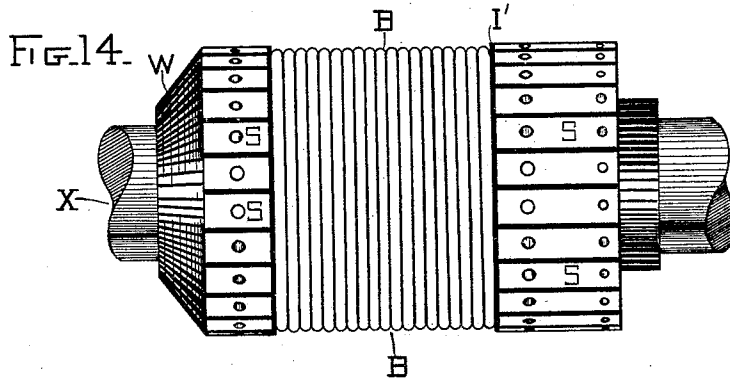
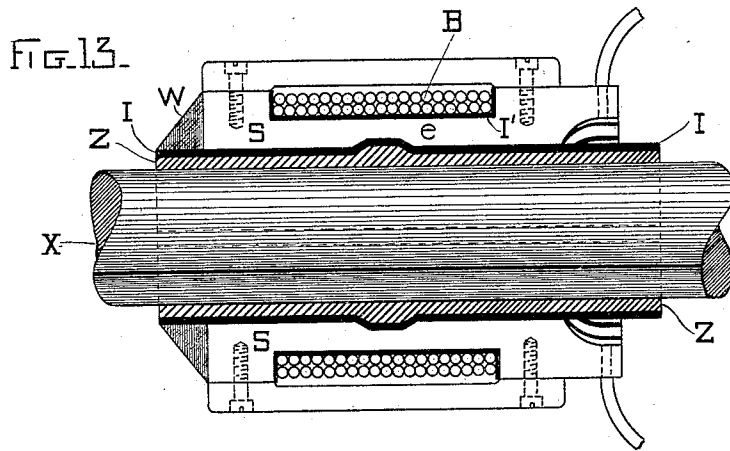

WITNESSES.

Henry Westendarp.
John W. Libboney

INVENTOR.

Elihu Thomson

UNITED STATES PATENT OFFICE.

ELIHU THOMSON, OF SWAMPSCOTT, MASSACHUSETTS, ASSIGNOR TO THE
GENERAL ELECTRIC COMPANY OF NEW YORK.

COMMUTATOR FOR DYNAMO-ELECTRIC MACHINES.

SPECIFICATION forming part of Letters Patent No. 523,019, dated July 17, 1894.

Application filed February 10, 1894. Serial No. 499,717. (No model.)

To all whom it may concern:

Be it known that I, ELIHU THOMSON, a citizen of the United States, and a resident of Swampscott, county of Essex, State of Massachusetts, have invented certain new and useful Improvements in Commutators for Dynamo-Electric Machines, of which the following is a specification.

My invention relates to commutators for dynamo-electric machines, and has for its object to provide a ready means of renewing the insulation between the segments or of correcting the defects in the face of the commutator by removing a few of its segments without turning down the whole commutator; to which ends I divide the commutator into a set of sub-segments and a set of wearing or surface-segments upon which the brushes bear, and insulate the various parts from one another in a way more particularly described hereinafter.

When a single spot or segment upon a commutator is softer than the surrounding parts, it wears away slightly, making what is termed a "flat" upon the commutator surface; as the brushes pass over this flat spot, they are apt to jump and leave the surface of the commutator, which is usually revolved at a somewhat high speed, and these jumps or irregularities produce more or less sparking, which being concentrated at a particular point, further increases the difficulty until eventually it is necessary to turn down the commutator until the bottom of the flat is reached; thus a large part of the copper in the commutator may be turned off and wasted to correct a small defect. This wasteful procedure has led to the adoption of the expedient I have named, that is, of making the commutator in two portions or sets of segments, one of these secured rigidly in place and having the leads from the armature coils fastened to it permanently, if desired, while the second set of segments is secured to the first in any suitable manner, and forms a wearing surface for the commutator; when a flat develops in one of these wearing segments, it may be at once corrected by removing the segment affected, or where the insulation between the adjoining segments has also become injured, by removing two or three of these wearing segments

and substituting new ones, then turning down these segments of the commutator to the size of the old parts; a great portion of the expense attending upon repairs is thus obviated, and it is many times possible to repair the commutator without sending it back to the factory or throwing the machine out of use except for a short time. While this procedure has great advantages, it has been found difficult to efficiently insulate the wearing segments, and it is to this particular difficulty that my present invention is addressed, it being exemplified in the annexed drawings forming part of this specification, and the novelty being pointed out in the claims.

In the drawings, Figure 1 is a longitudinal section of a commutator embodying my invention. Fig. 2 is an end elevation partly in section of the part shown in Fig. 1. Fig. 3 is a single segment and wearing segment shown separately. Fig. 4 shows two arrangements of the insulating material, the segments being shown in section. Figs. 5, 6, 9, 10, and 11 show various shapes of insulating material. Figs. 7 and 8 are plan views of sub segments. Fig. 12 shows two additional modes of placing the insulation. Fig. 13 is a view in elevation of a commutator partly in longitudinal section, showing a means for mounting the segments on the shaft. Fig. 14 is a view of the commutator in Fig. 13, showing the wearing segments removed, and Fig. 15 is a detail view partly in section, of a complete mounted segment.

In Figs. 1 and 2, S, S, &c., are the sub-segments mounted, as shown, upon commutator sleeves surrounding the shaft, with interposed insulation, shown in heavy black lines.

Lugs or extensions are provided at L with openings for the attachment of the armature leads, which may be soldered or otherwise fastened to the segments.

W, W, represent wearing segments, part of which are shown in section in the upper right hand part of Fig. 2. These wearing segments are secured by screws, V, V, to the sub-segments. The insulation between the wearing segments fills not only the space between the two adjacent segments but also the space between the wearing segment and the sub-segment; this space being formed by cutting away

the face of the sub-segment S at t , or cutting away the under side of the wearing segment, or both, and being more distinctly seen in Fig. 3, where a single segment is shown separately for clearness of illustration, the sub-segment S being of different shape from that shown in Figs. 1 and 2.

There are several ways in which the insulation between the wearing segments may be applied. Two of these ways are illustrated in Fig. 4 wherein the right half of the figure is shown with the insulating material I, I , in heavy black, wrapped around the under side of the wearing segment and projecting up at the sides. In this case half the segments, as $W', W', W', \&c.$, would be attached to the sub-segments by screws without any insulating material, while the remaining bars, $W, W, W, \&c.$, would have the insulating material made in channel form and placed in position under the segment while it is being drawn down into place; by which construction the insulating material takes its position or forms itself between the adjacent segments and is held in place by passing underneath one half of them. In the left part of Fig. 4 I show the more obvious arrangement of putting the insulation under each of the segments W^2, W^2, W^2 , and drawing them down into place. This gives a double thickness between the segments, and the insulation would be made of half thickness. The insulating material may be mica or mica paper sheets or layers superimposed and bent into form for use, or bent during the act of placing it into position, or any other suitable material. The inner edges of the wearing segments should be rounded where the insulation turns a corner, and I prefer to cut it away underneath the wearing segments where the screws pass through, so as to get a good metallic bearing independently of any variation of thickness in the insulation between the sub-segments and the wearing segments, thus insuring ample electrical contact also. The sub-segments may, of course, be made of metal different from that of the wearing segments.

The shape of the pieces of insulation which would be used is indicated in Fig. 5, where the pieces are shown flat, and the dotted lines indicate the places of bending to form.

In Fig. 5 the spaces or notches a, a , are for the passage of the screws that unite the wearing segments to the sub-segments, while the part b underlies the wearing segments.

In Fig. 6 I show that the piece may be made of two halves each of which is bent on a dotted line to form the portion b which goes under the wearing segment. In this case the pieces on end would be of L form with edges meeting under the segment, as at I^3 in Fig. 4.

Fig. 7 is a top view of such a segment as is used in Fig. 1, where a^2, a^2 represent surfaces in which the screw holes are tapped, and which match the notches a, a , of the piece Fig. 5, while t is the cutaway portion which re-

ceives the bridge part b underlying the wearing segment.

Figs 8 and 9 show a segment and insulating piece respectively, in which there is an extra bearing surface a' on the segment and an extra opening a^3 in the insulating piece, and in like manner this insulating piece may, as in Fig. 10, be composed of two halves corresponding to Fig. 6. The portions b, b , of the insulating piece which underlie the wearing segment may be, as shown in Fig. 11, overlapped; that is, the pieces may be made of bent plates of insulation, the parts under the segments being doubled by overlapping of two extensions from an insulating piece on each side of the wearing segment.

As shown in the left of Fig. 12, the insulating pieces I^2, I^2 , under the wearing segments $W, W, \&c.$, are bent into an L shape, as seen on end, and this is a convenient way of arranging the insulation.

In Fig. 12, on the right, the insulating pieces I', I' , are, as in Fig. 11, bent under the segments $W, W, \&c.$, and there form a double thickness; that is, the pieces on each side of the segment lap under it, one above the other, while the pieces between the segments are doubled, one passing under the segment to the right and the other to the left.

Instead of holding the sub-segments to the commutator in the usual way by tapering their ends and clamping them endwise, I have devised a method suitable to the practice of my invention which is shown in Figs. 13, 14 and 15, and which consists in arranging, as shown in Figs. 13 and 14, the sub-segments with a sleeve or support Z secured upon the shaft X , there being a layer of insulating material, as shown at I, I , underlying the sub-segments or supporting segments S, S , and the sleeve Z . The sub-segments S are assembled around the sleeve Z which may have a slight expansion, as at e , entering into a corresponding internal groove in the range of sub-segments S for the purpose of preventing end motion of the segments on the sleeve Z . Any other means might be used for the same purpose and the expansion e is by no means essential to be used where the sub-segments S, S , are bound firmly to the underlying sleeve or to the shaft. To hold the sub-segments in place I cut a deep groove, one or more, around the said body of segments and insulate the inside of the groove, as indicated at I' , for the reception of a binding wire, or a band of any suitable character. This might be a hard unelastic cord cemented in place, or the binding may be composed of wire, insulated or not, laid on with considerable tension and forming a complete metallic binding holding the segments S, S , in place, or the binding B might be replaced by strips or rings made in sections and drawn together in any suitable fashion.

With the binding B in place the segments, as is evident, will be held down firmly and yet

insulated from each other, as the binding B does not touch any of them. In other respects said segments are the same as those in Figs. 1 and 2, and may have the wearing portion mounted thereon in the same way, and insulated from each other in the ways pointed out in the prior figures.

It is desirable, as indicated in Figs. 13 and 14, to cover up the end of the sub-segments by a ring of insulating material W, shown as covering only a single end of the sub-segments. The other end, or the one carrying the lugs for the attachment of the armature leads, can likewise be protected by a ring of insulating material.

In Fig. 15 there is shown a preferable arrangement of the band B, which in this case, if made of conducting material, is entirely inclosed in an insulating casing, or separated by insulation, top, bottom, and sides, whereby any leakage from one segment to the band and from the band to any other segment is prevented. Space, in each case, is of course always left underneath the wearing segments for the passage of its own particular insulating sheet when bent inward, as described in the former figures. Minor variations from these arrangements are made while not departing from the essence of my invention.

What I claim as new, and desire to secure by Letters Patent of the United States, is—

1. In a commutator for dynamo-electric machines or motors, a supporting body, sub-segments carried by such supporting body and insulated therefrom, each sub-segment being provided also with a wearing segment mechanically and electrically connected thereto, such wearing segments provided with insulation distinct from that of the sub-segments.

2. In a commutator for a dynamo-electric machine or motor, a supporting body, a series of sub-segments insulated from the supporting body and from each other, each sub-segment having a cut-away portion as *t*, a series of wearing segments attached to the sub-segments, and insulation of L-shaped cross-section arranged between the wearing segments and extending into the cut-away portion of

the sub-segments; whereby single wearing segments may be removed and reinsulated without disturbing or affecting the insulation of the other segments.

3. In a commutator for a dynamo-electric machine or motor, a series of sub-segments insulated from each other in combination with a series of wearing segments corresponding to the sub-segments, and strips of insulation between the adjoining wearing segments, said strips turned under the wearing segments and thereby prevented from escape during the rotation of the commutator.

4. A commutator having sub-segments and removable wearing segments corresponding thereto, and insulating strips passing under alternate wearing segments, the edges of which strips are located between the adjacent wearing segments for insulating them from each other.

5. In a commutator, a series of sub-segments surrounded by a band, insulated as described, whereby said sub-segments are held in place, in combination with an outer set of wearing segments secured to the sub-segments.

6. In a commutator, a set of sub-segments secured from expansion radially by a surrounding insulated band, one or more, together with a set of wearing segments insulated from each other by strips of insulating material which turn under the wearing segments.

7. In a commutator, a supporting sleeve or shaft surrounded by a layer of insulating material upon which are carried sub-segments insulated laterally from each other and held in place by a band or ring suitably insulated from the sub-segments, and a set of wearing segments removable at will and insulated from each other by strips of insulating material, which bands turn under said wearing segments.

In witness whereof I have hereunto set my hand this 8th day of February, 1894.

ELIHU THOMSON.

Witnesses:

JOHN W. GIBBONEY,
BENJAMIN B. HULL.