

# ORIGINAL

## ABSTRACT

### 'JOINT BUILDING SYSTEM FOR BOX STRUCTURES'

The present invention solves a problem of building geometry in a system to assemble and shut exclusively by jointing the six walls of a box parallelepiped built up with at least seven plates, so:

- the *plates* are divided in a first group of six, named *primary*, each one provided with a couple of *grooves*, and in a second group of the remaining *plates*, named *secondary*, not necessarily grooved;
- the *walls* of the structure are divided in two types: *single walls*, composed by only one *primary plate*: *multiple walls*, composed by one *primary plate* and at least one *secondary plate*;
- the *structure*, which must have at least one *multiple wall*, is assembled and shut jointing together first the six *primary plates* and then introducing at least one of the *secondary plates*.

The system is suitable to build countless artefacts.

WE CLAIM:

1. A joint building system for firmly assembling and shutting a box structure, comprising:

at least seven plates made up of sheet stiff material, wherein:

said at least seven plates are divided into a first group, of six plates, or primary plates, each one of said six primary plates being provided with a pair of opposite mating structures, each mating structure comprising at least one of a groove or fold, and a second group of plates, or secondary plates, comprised of the remaining plates of said at least seven plates minus said six primary plates, each one of said secondary plates being optionally provided with one or more mating structures;

said box structure having single walls comprised of a single plate among the primary plates, and/or multiple walls comprised of one plate among the primary plates and at least one of said secondary plates, at least one of the walls of said box structure being a multiple wall;

said plates configured to allow assembling of said box structure by assembling first said six plates of the primary group, and then said at least one plate of said secondary plates.

2. A joint building system according to the preceding claim, wherein said plates are comprised of a stiff material, such as wood, plywood, glass, stone, metal, plastic, as well as any combination of the same.

3. A joint building system according to any one of the preceding claim, wherein said mating structures of each of said primary plates extend, at least partially, along the side of the plate.

4. A joint building system according to any one of the preceding claim, wherein each of said secondary plates is provided with a pair of opposite mating structures, which extend, at least partially, along the side of the plate.

5. A joint building system according to any one of the preceding claim, wherein each of said mating structures of said primary plates are configured to receive one edge of one of said primary plates, and wherein at least one of said mating

structures of said primary plates is configured to further receive at least one edge of said at least one secondary plate.

6. A joint building system according to claim 5, wherein said mating structures configured for receiving multiple walls are wider than mating structures that are configured for receiving single walls.

7. A joint building system according to any one of the claim 1 - 5, wherein the mating structures of said primary plates comprise grooves, and the width of said grooves of each of said primary plates is equal to the thickness of the wall to be received in said groove.

8. A joint building system according to any one of the claim 1 - 6, wherein the mating structures of said primary plates comprises a pair of folds, and the distance (L) between said pair of folds of said primary plates is equal to a width (W) of the wall perpendicular to its edge plus the thickness of the opposite walls received perpendicular to its folds.

9. A joint building system according to any one of the claim 1 - 7, wherein said plates are extended also in the orthogonal direction in respect to said mating structures.

10. A joint building system according to any one of the preceding claims, wherein each of said secondary plates have a stick or rod shape.

11. A joint building system according to any one of the preceding claims, wherein said mating structures of said primary plates comprise further pairs of grooves.

12. A joint building system according to any one of the preceding claims, wherein said multiple walls further comprise further fixing means.

13. A joint building system according to any one of the preceding claims, wherein said plates are internally and/or externally shaped in any of the three dimensions.

14. A joint building system according to any one of the preceding claims, wherein plates within a frame shape receive, on the edges of respective internal sides, the mating structures of the other plates.

15. A method for assembling a box structure employing a joint building system as described in any one of the claims 1 - 14, comprising:

- coupling said mating structures of each of said six primary plates with the edges of the remaining primary plates,
- inserting at least one secondary plate in one of the mating structures of said primary plates.

16. A box structure comprising:

six primary plates, each one of said six plates being provided with a pair of opposite mating structures, each of said mating structures comprising at least one of a groove or fold, and

at least one secondary plate, wherein:

each of said mating structures of said primary plates being configured to receive one edge of said primary plates, and  
at least one mating structure of said primary plates being configured to further receive at least one edge of said secondary plates.

Dated this 9<sup>th</sup> day of April, 2012

  
(Ranjan Narula)  
Of Ranjan Narula Associates  
Agent for the Applicant

APPLICANT: GIUSEPPE, MASCI  
APPLICATION NO.:

NO. OF SHEETS - 13  
PAGE 1 OF 13

ORIGINAL

3013 DELNP 12

09 APR 2012

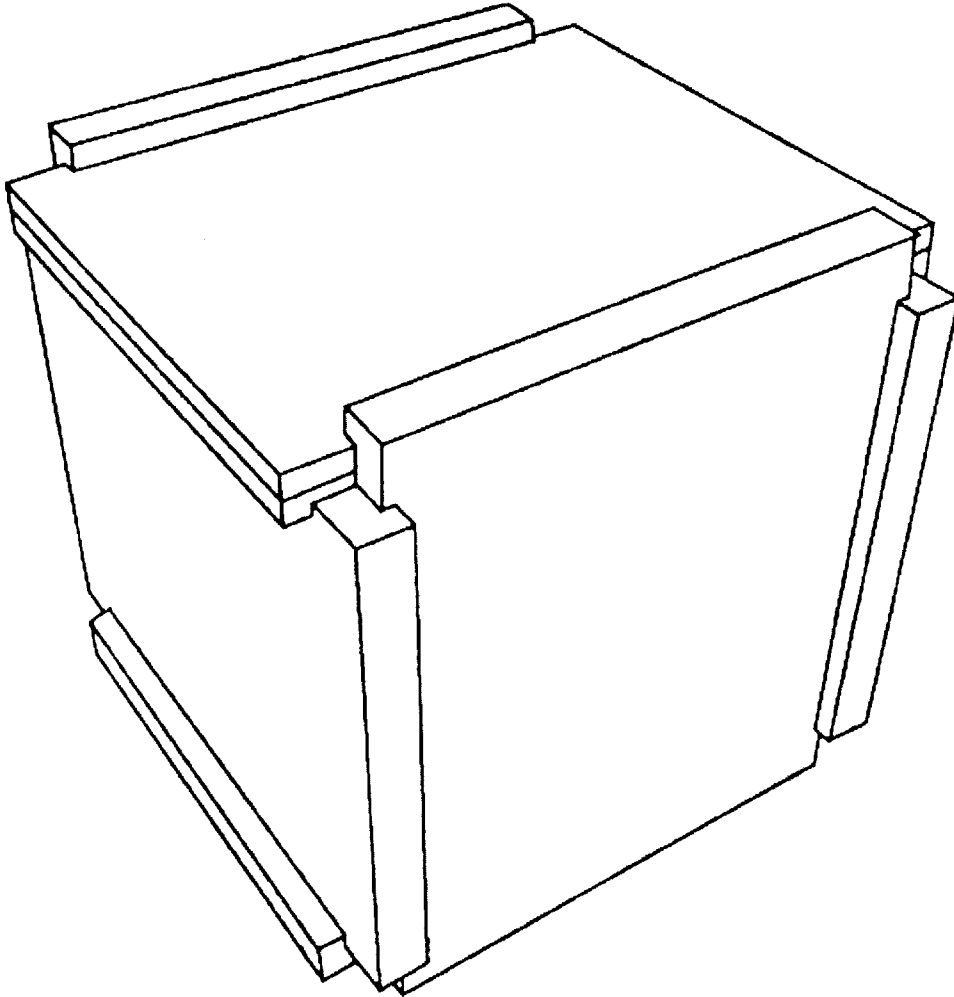

Fig. 1

(RANJAN NARULA)  
Of **Ranjan Narula Associates**  
Agent for the Applicant

9 APR 2012

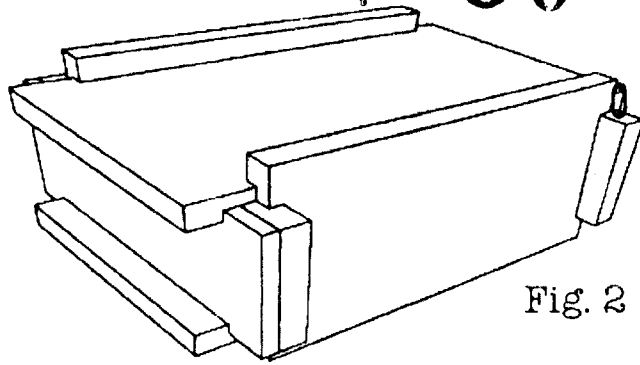

Fig. 2

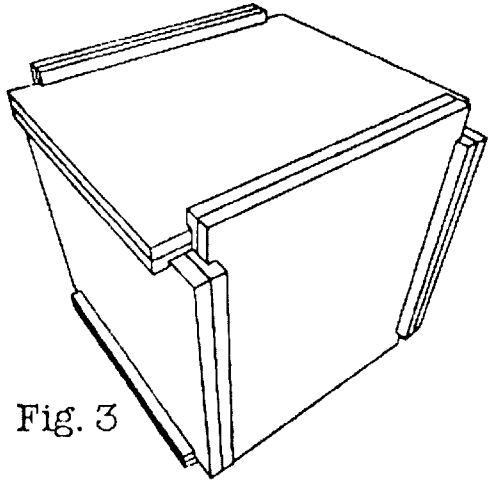

Fig. 3

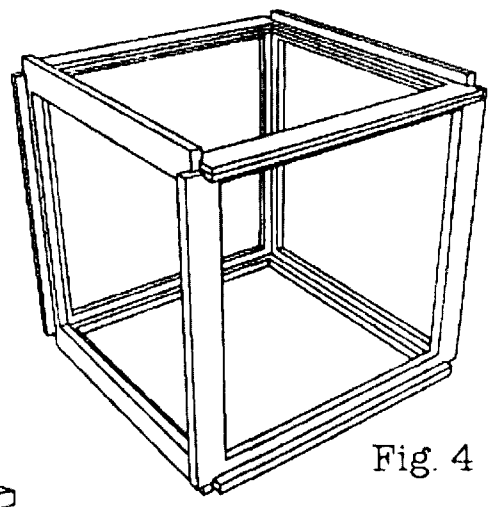

Fig. 4

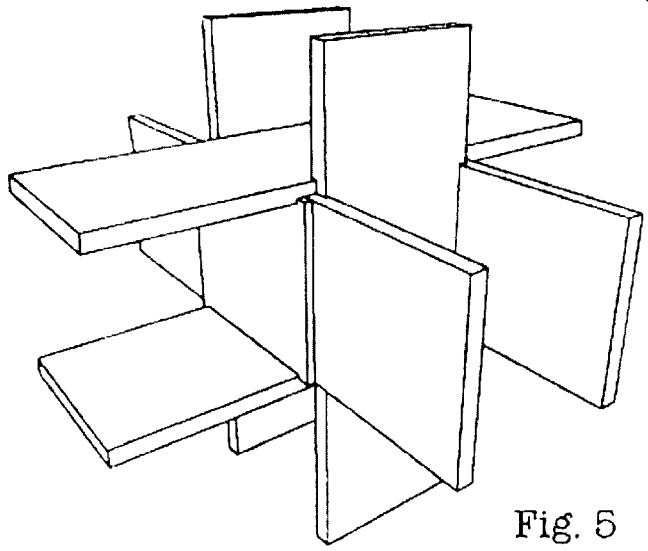

Fig. 5

(RANJAN NARULA)  
Of **Ranjan Narula Associates**  
Agent for the Applicant

ORIGINAL

3013 DELNP 12  
Fig. 6

09 APR 2012

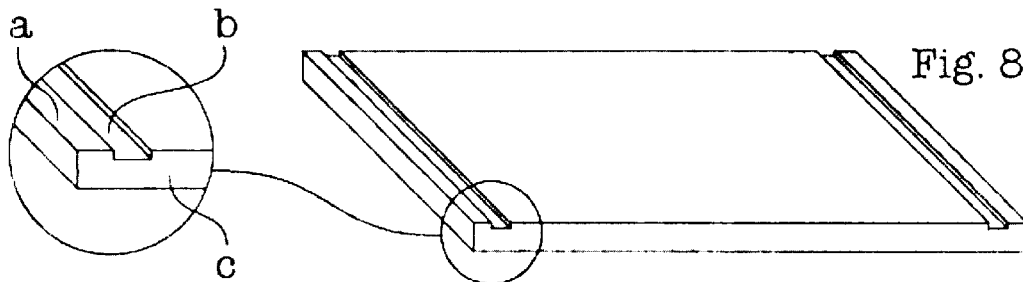
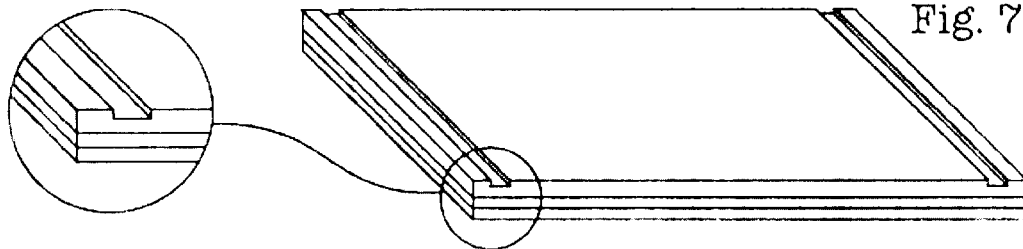
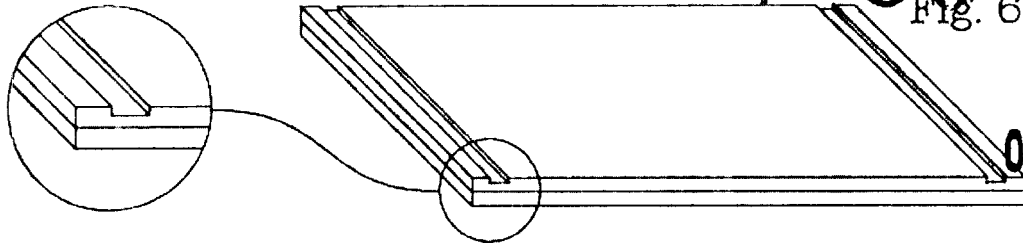

(RANJAN NARULA)  
Of **Ranjan Narula Associates**  
Agent for the Applicant

**3013 DELNP 12**

09 APR 2012

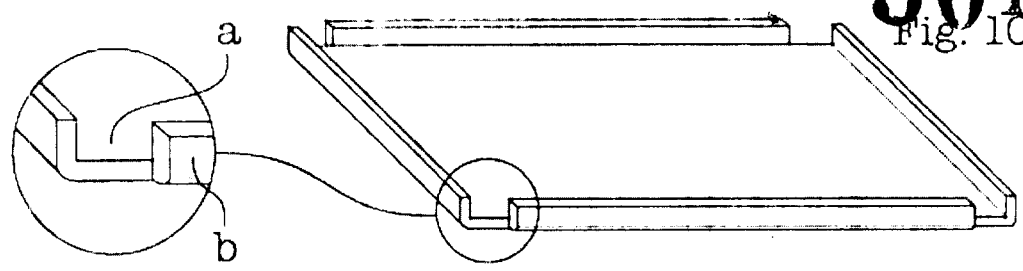

Fig. 10

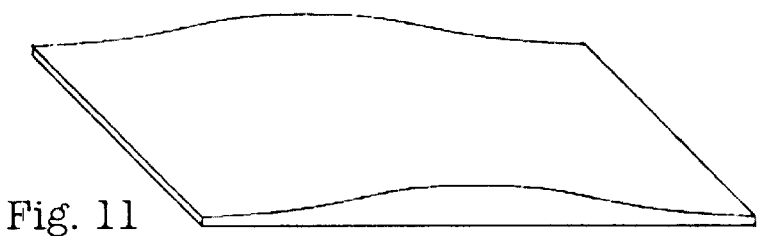

Fig. 11

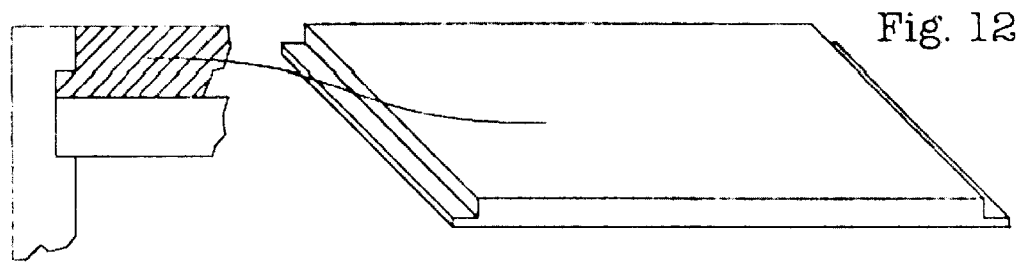

Fig. 12

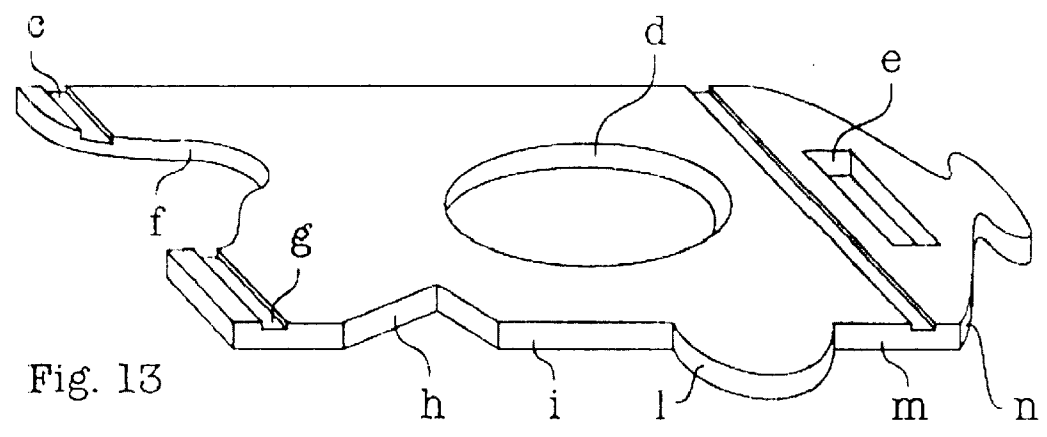
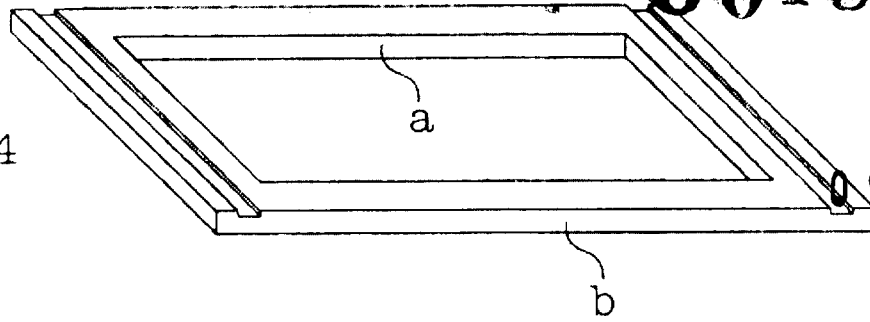

Fig. 13

(RANJAN NARULA)  
Of **Ranjan Narula Associates**  
Agent for the Applicant

3013 DEENP 12

Fig. 14



09 APR 2012

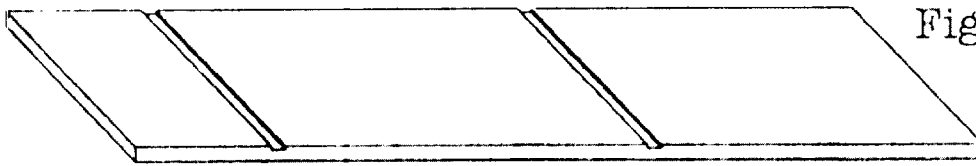

Fig. 15

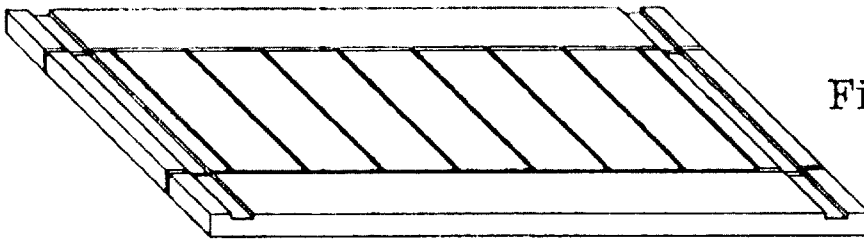
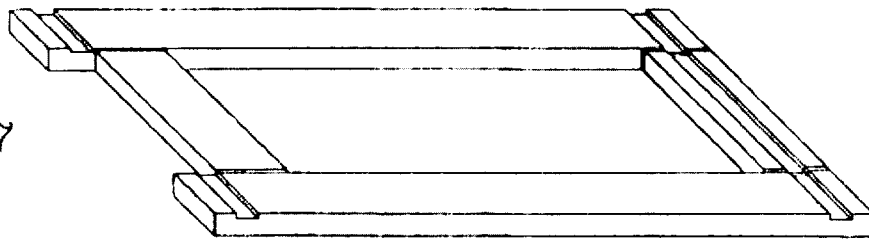

Fig. 16

Fig. 17



(RANJAN NARULA)  
Of **Ranjan Narula Associates**  
Agent for the Applicant

3013 DELNP 12

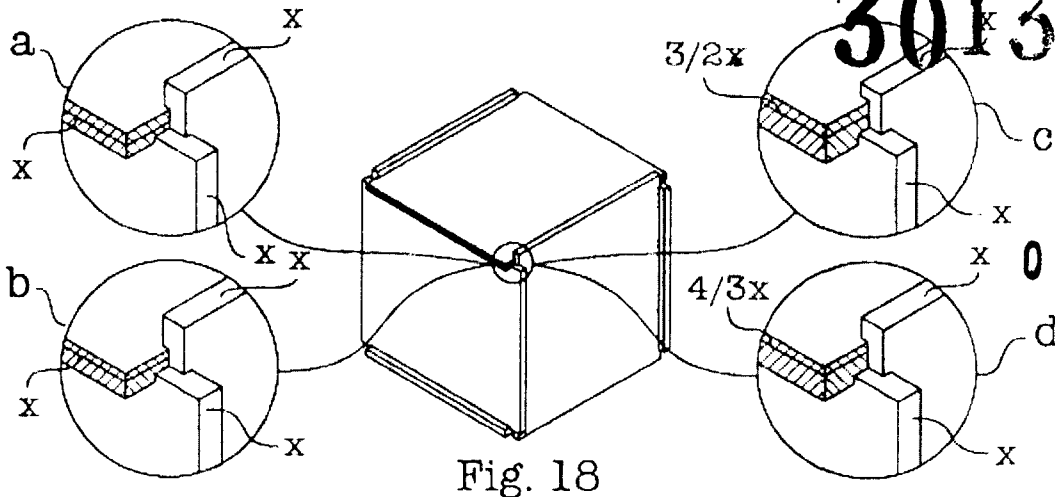

Fig. 18

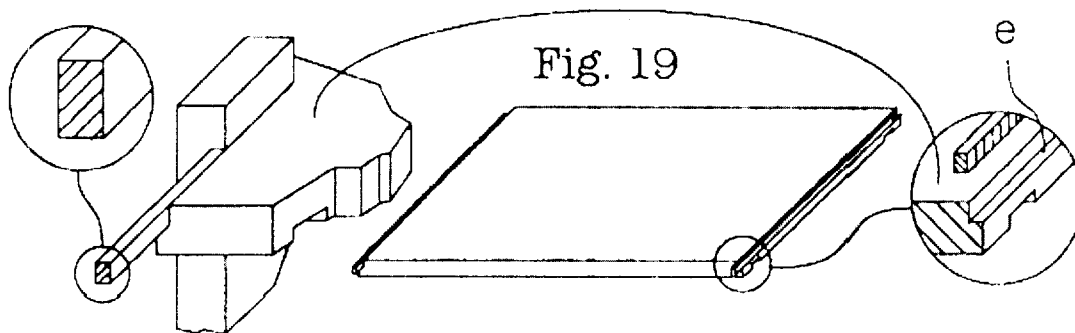

Fig. 19

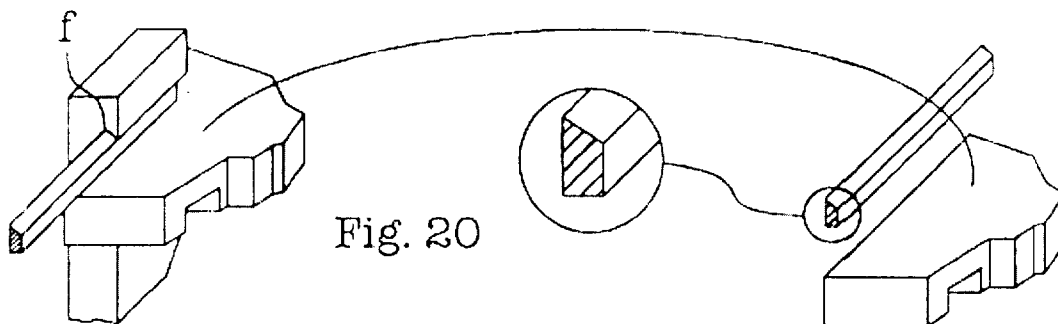

Fig. 20

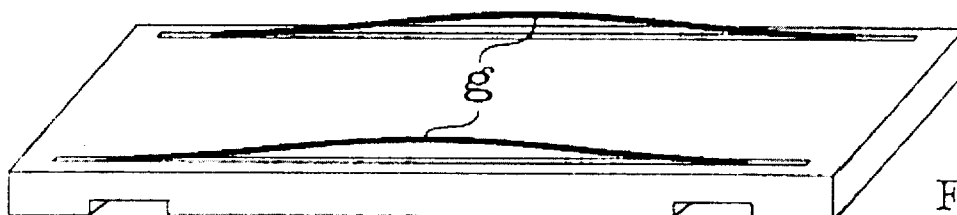

Fig. 21

(RANJAN NARULA)  
Of Ranjan Narula Associates  
Agent for the Applicant

3013 DELNP 12

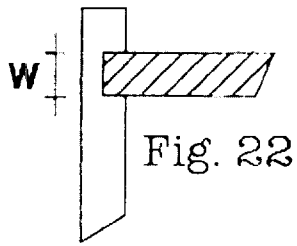

Fig. 22

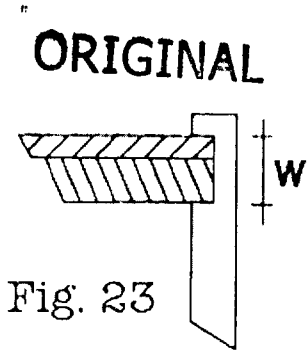

Fig. 23

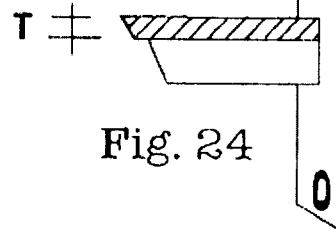

Fig. 24

09 APR 2012

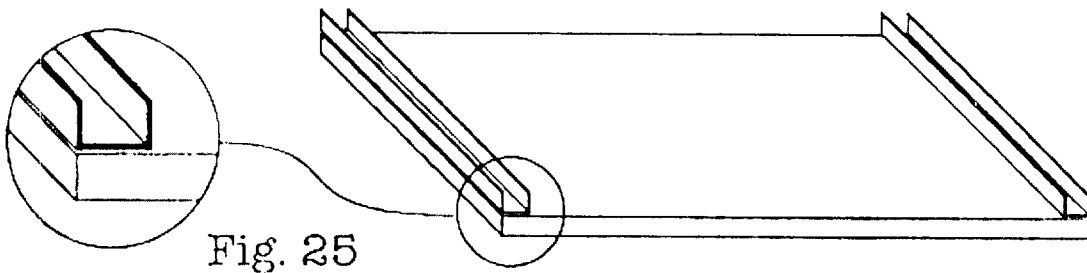

Fig. 25

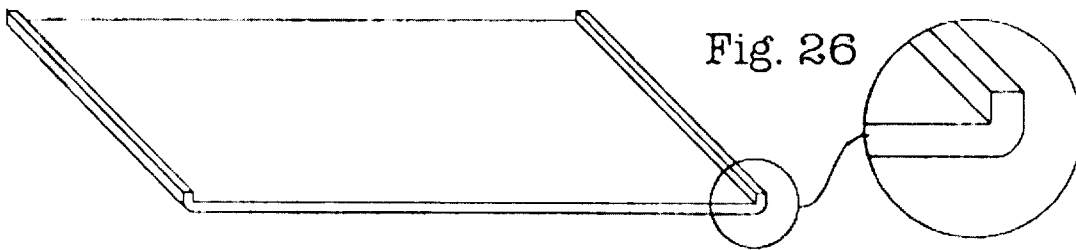

Fig. 26

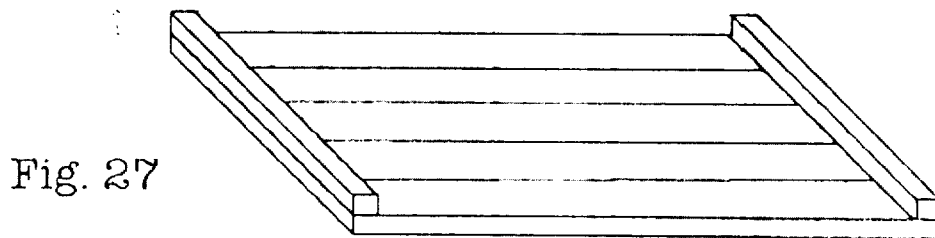
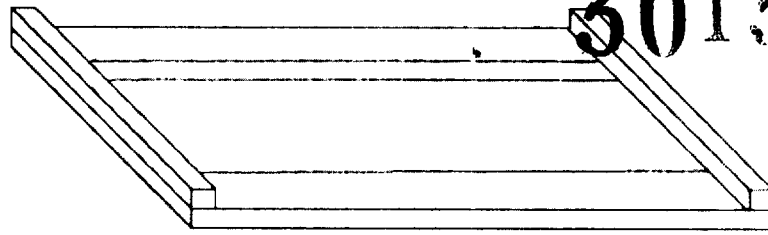

Fig. 27

(RANJAN NARULA)  
Of Ranjan Narula Associates  
Agent for the Applicant

3013 DELNP 12

Fig. 28



09 APR 2012

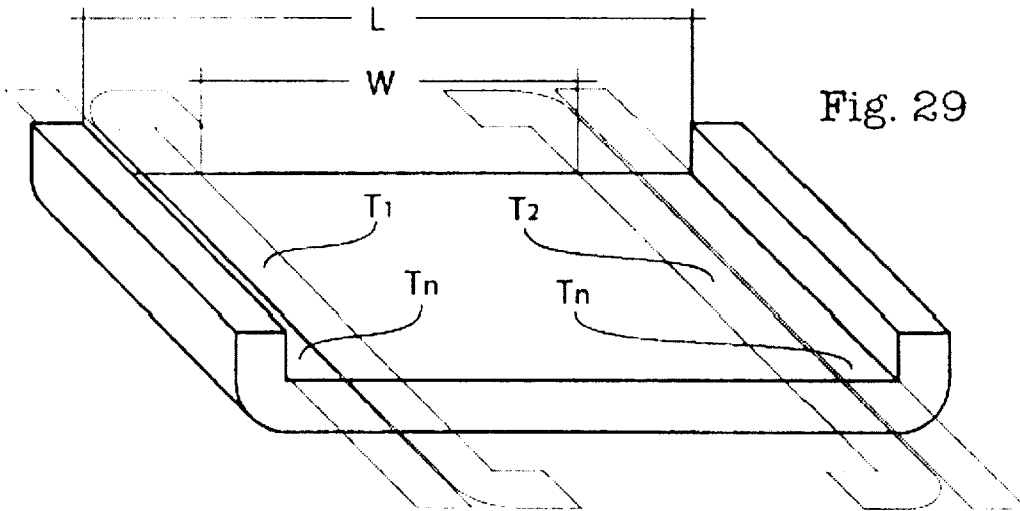
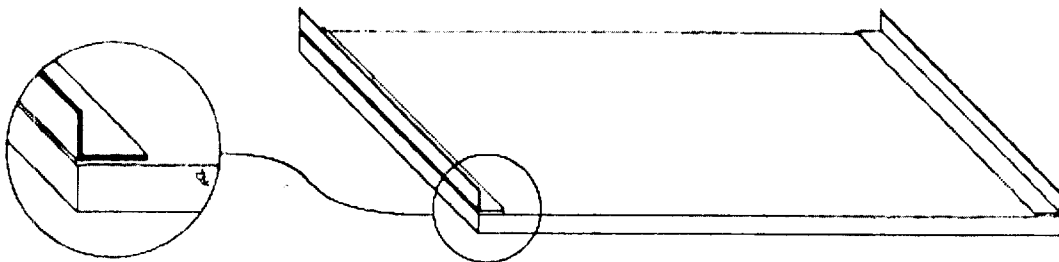

Fig. 29

Fig. 30



(RANJAN NARULA)  
Of **Ranjan Narula Associates**  
Agent for the Applicant

**3013 DELNP 12**

09 APR 2012

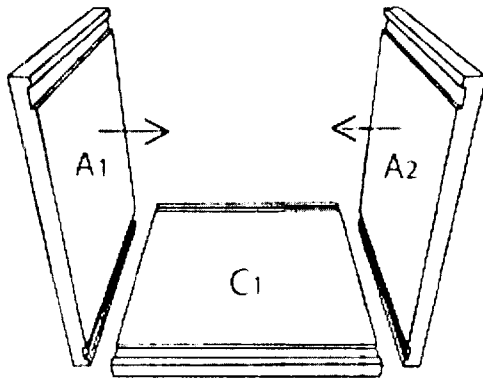

Fig. 31

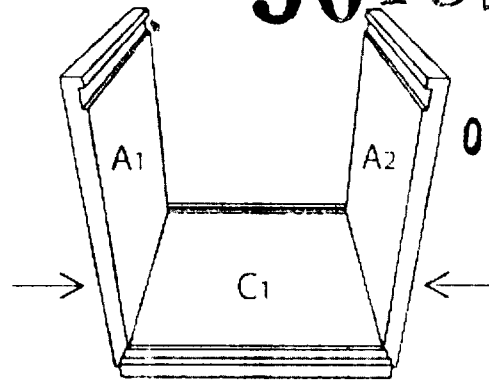

Fig. 32

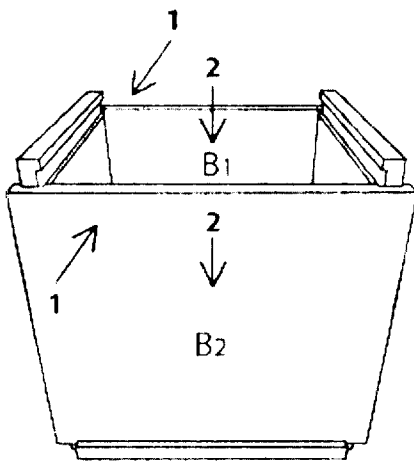

Fig. 33

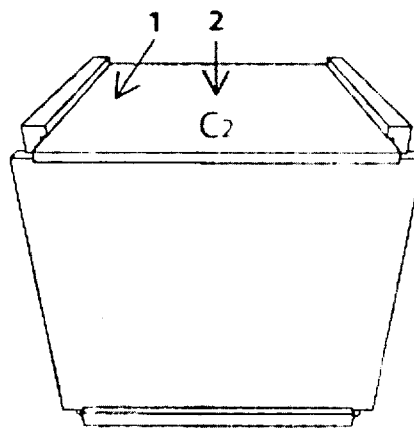

Fig. 34

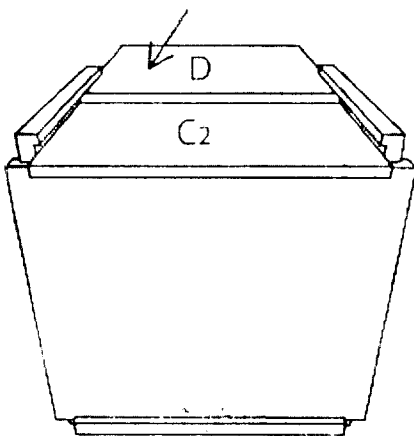

Fig. 35

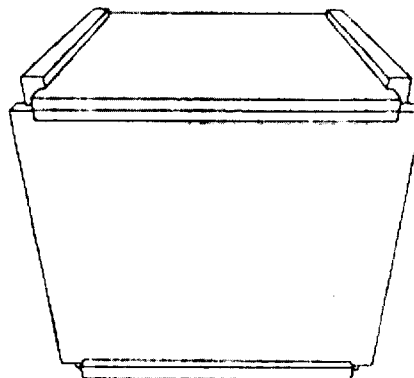

Fig. 36

(RANJAN NARULA)  
Of **Ranjan Narula Associates**  
Agent for the Applicant

3013 DELNP 12

09 APR 2012

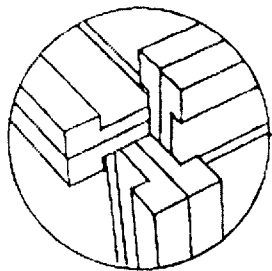

Fig. 37

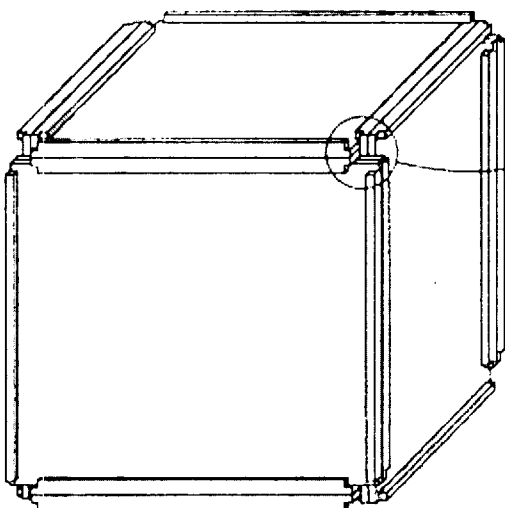
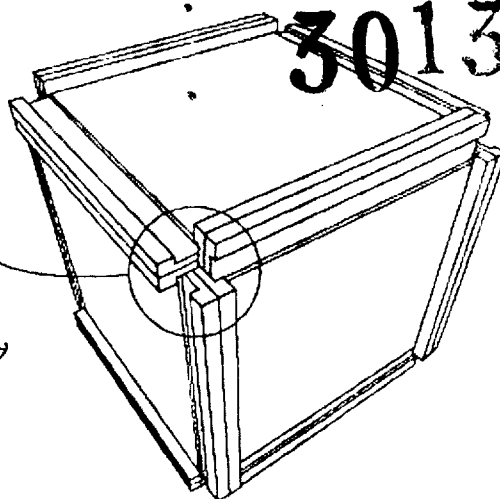

Fig. 38

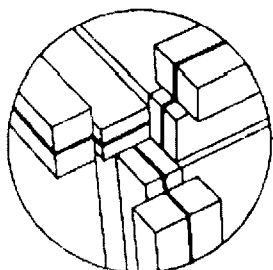
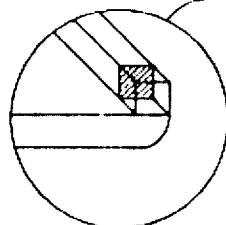
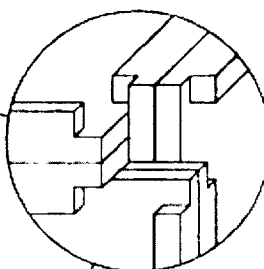
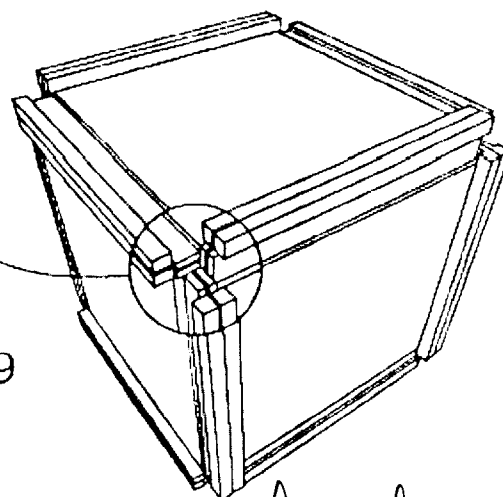

Fig. 39



(RANJAN NARULA)  
Of Ranjan Narula Associates  
Agent for the Applicant

3013 DELNP 12

09 APR 2012

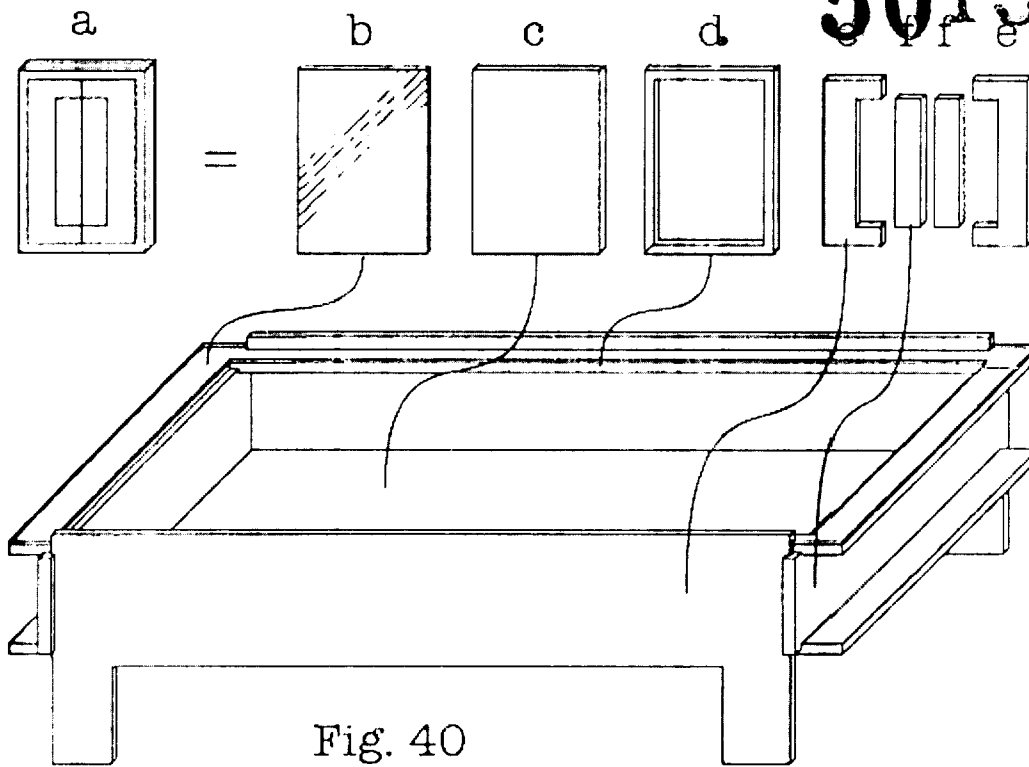
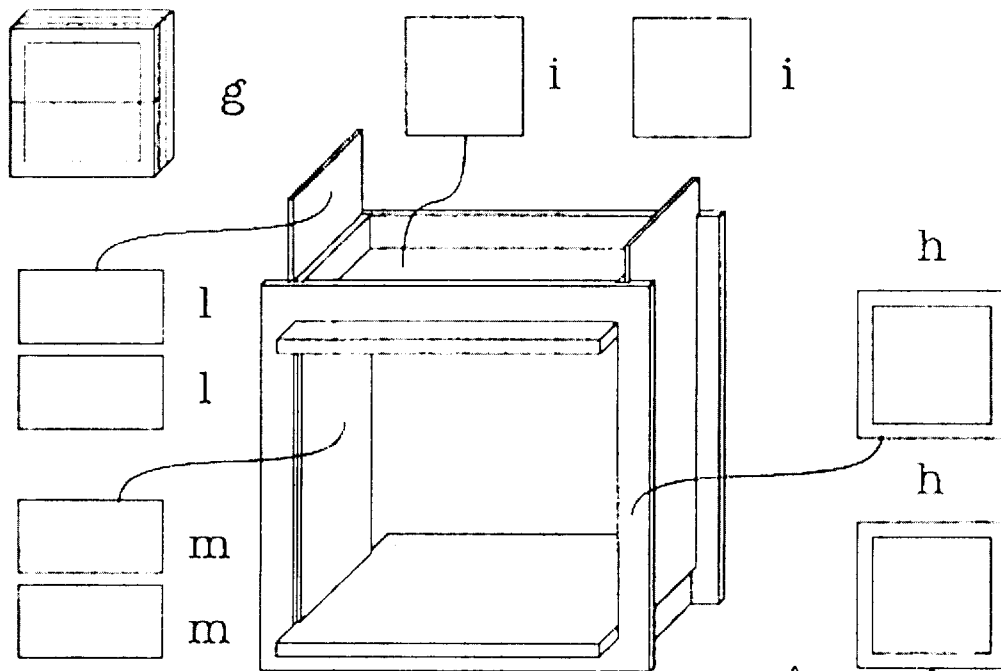

Fig. 40

Fig. 41



(RANJAN NARULA)  
Of **Ranjan Narula Associates**  
Agent for the Applicant

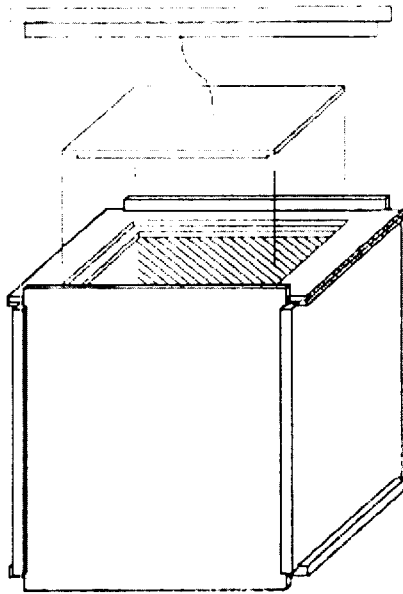

Fig. 43

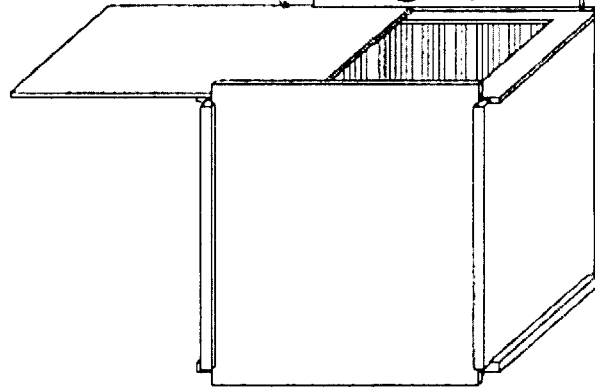

Fig. 42

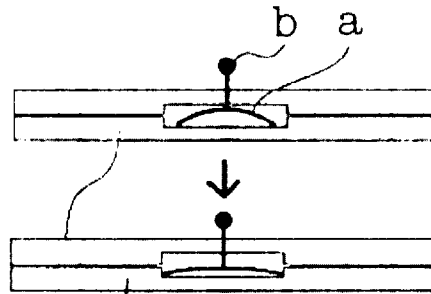

Fig. 44

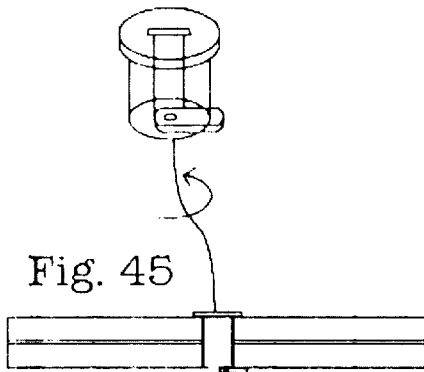
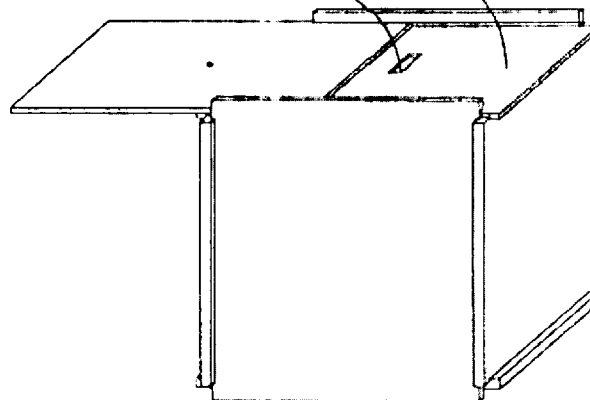

Fig. 45



*Ranjan Narula*  
(RANJAN NARULA)  
Of Ranjan Narula Associates  
Agent for the Applicant

09 APR 2012

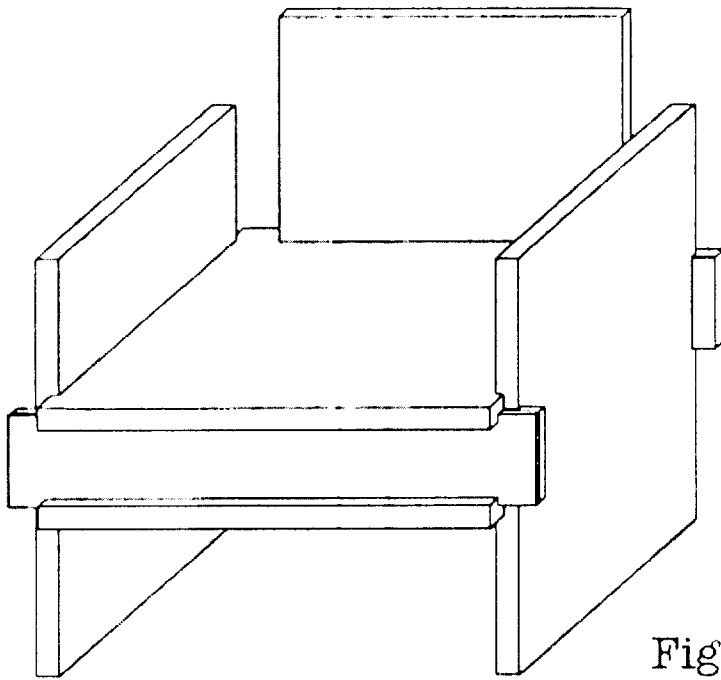

Fig. 46

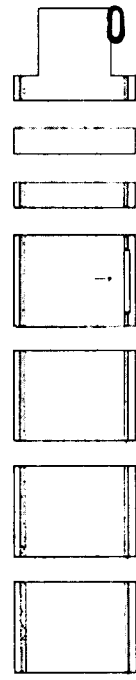
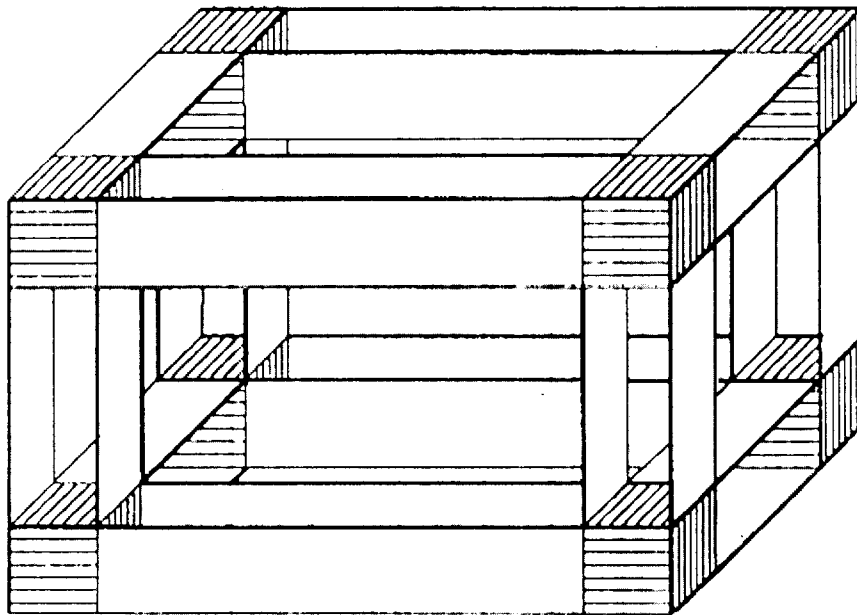

Fig. 47



(RANJAN NARULA)  
Of Ranjan Narula Associates  
Agent for the Applicant

## DESCRIPTION

### TECHNICAL FIELD

The present invention can be placed in the field of the building geometry solutions applicable to a big number of industrial products.

It consists in *a joint building system to assemble and to shut the six walls of a box parallelepiped at the minimal possible condition to split at least one wall of the structure in at least two plates.*

From a practical point of view, the flexibility of the building system allows to create countless artefacts, also complex, which in the most of the cases are built up with only seven elements simply jointed together.

This system allows to joint together several structures, then it can be considered also a *nodal joint* for building complex structures.

Finally a particular characteristic of the invention, *allowing to assemble twelve plates all perfectly identical in a cube*, could pertain to other fields of belonging.

### BACKGROUND ART

The background art of the present invention concerns mainly in the solution of the building geometry problem above mentioned.

We cannot refer to any existent techniques about this aspect.

The background art concerns as well the set of elements and of technical characteristics that exist separately in other joint systems, even complex.

Also in this case it is difficult to give any information about building systems like that in object for the variety of its configurations and its applications.

## DISCLOSURE OF INVENTION

According to the first aspect, the present invention consists in a *joint building system* that allows to assemble and shut firmly, without any other brackets, *box structures*, including:

- at least seven *plates* of sheet stiff material, characterised by:
  - the *plates* are divided in a first group of six, named *primary*, each one provided with a couple of *grooves*, and in a second group of the remaining *plates*, named *secondary*, not necessarily grooved;
  - the *walls* of the structure are divided in two types: *single walls*, composed by only one *primary plate*; *multiple walls*, composed by one *primary plate* and at least one *secondary plate*;
  - the *structure*, which must have at least one *multiple wall*, is assembled and shut jointing together first the six *primary plates* and then introducing at least one of the *secondary plates*.

The terms "*primary*" and "*secondary*" recall the order in which the plates must be assembled.

Examples of *box structures* are shown in Fig. 1-2-3-4-5.

Examples of *multiple walls* are shown in Fig. 6-7.

Examples of *primary* and *secondary plates* are shown in Fig. 8-9.

According to another aspect, the present invention consists in a *joint building system*, including at least seven *plates*, characterised by:

- the *plates* can be made of any stiff material such as wood, plywood, glass, stone, metal, plastic, and used also in mixed types;
- the *plates* can be strengthened with stiffening ribs and/or by folding materials, Fig. 10 (b);
- the *plates* can have predetermined free dimensions, thickness included, Fig 11-12;

- the *plates* can also be *modelled* internally and/or externally to their perimeter, Fig. 13, *frame shape* included, Fig. 14;
- the *plates* can also be *prefabricated*, then composed by previously assembled elements, even if simply jointed, Fig. 16-17.

According to another aspect, the present invention consists in a *joint building system*, including at least seven *plates*, characterised by:

- each one of the six *primary plates* has a couple of *grooves*, in a way that they can be jointed together, with *ribs* of the ungrooved sides of each one in the *grooves* of other ones, Fig. 8.
- the *primary plates* can be *modelled*, provided that some segments of the grooved sides and of the ungrooved side *ribs* are preserved, sufficiently to joint firmly the elements of the structure, Fig. 13.
- the *primary plates* can be *extended* also in the orthogonal direction to the *grooves*, Fig. 15.

According to another aspect, the present invention consists in a *joint building system*, including at least seven *plates*, characterised by:

- in order to block the *structure*, at least one *secondary plate* must be inserted in remaining space of the *grooves*, receiving it, which have been suitably sized for this purpose, Fig. 35,
- the *secondary plates* can take all the same possible shapes of the *primary plates*, grooved shapes included;
- the *secondary plate* can have a *complementary* thickness with its coupled *primary plate*, so their total thickness is equal to the other walls one, Fig. 18 (a,b).
- the *secondary plate* can have a *supplementary* thickness with its coupled *primary plate*, so their total thickness is bigger than the other walls one, Fig. 18 (c,d).

The preferred embodiment of the present invention provides for one or more elements named *secondary plates*.

This should not be seen as a limitation, indeed it does not produce any change in the framework of the present invention, so that:

- the *secondary plate* can be replaced by any *device* carrying out an identical role, Fig. 19-20-21.

According to another aspect, the present invention consists in a *joint building system*, including at least seven *plates*, characterised by:

- the *grooves*, arranged for jointing, are situated - in parallel rectilinear couples - at the edges of two opposite sides of each one of the six *primary plates*, Fig. 8.
- the *grooves* can be also discontinuous and/or in minimum quantity, Fig. 10 (a);
- the width of *grooves* is equal to the thickness of the *single or multiple wall* received, Fig. 22-23,
- the depth (D) of *grooves* is minor or equal to the thickness (T) of the *secondary plate or plates* received, Fig. 24;
- for *grooves* must be intended also any *device*, applied to the plates, that can carry out the same roles, Fig. 25.

In the formulation of the present invention, the characteristic of the *primary plates* is represented by the *grooves*.

This should not be seen as a limitation, because the framework of the system in object, is still unchanged in the following aspect.

According to another aspect, the present invention consists in a *joint building system*, including at least seven *plates*, characterised by:

- each one of the six *primary plates* is provided with a couple of *folds* (in this case the attribute of the joint is with one-sided containment), Fig. 26-27-28, so they can be jointed together, with *ribs* of the unfolded side of each one inside the folds of the other one;
- the *primary plates* can be *modelled*, provided that some segments of the folded sides and of the unfolded side *ribs* are preserved, sufficiently to joint firmly the elements of the *structure*;
- the *folds* are situated, in parallel couples, at the edges of two opposing sides of each one of the six *primary plates*;

- the *fold*s are rectilinear, arranged for jointing, even if they are in discontinuous and/or in minimum quantity;
- the depth of *fold*s is minor or equal to the thickness of the *secondary plate* or *plates* received,
- the internal length (L) of a *primary plate*, from *fold* to *fold*, is equal to the width (W) of the hosting *wall*, plus the thickness ( $T_1, T_2...T_n$ ) of the *plates* received, Fig. 29.
- for *fold* must be intended also any *device*, applied to the *plates*, that can carry out the same roles, Fig. 30.
- in order to block the structure, at least one *secondary plate* must be inserted in the remaining free space amid the *primary plate* and the *fold*s, receiving it, and that are properly sized for this purpose.

According to another aspect, the present invention consists in a *joint building system*, including at least seven *plates*, characterised by:

- the **procedure** to assemble a minimal *box structure* built up with seven *plates* is carried out through the following steps shown in Fig. 31 to 36:

The couples of the opposed *primary plates* are marked by  $A_1-A_2, B_1-B_2, C_1-C_2$  and the *secondary plate* is marked by D;

- $C_1$  is jointed in  $A_1$  and  $A_2$ , Fig. 31-32;
- $B_1$  and  $B_2$  are jointed, movement (1), on  $A_1$  and  $A_2$  and then they are pushed downward, movement (2), in  $C_1$ , Fig. 33;
- $C_2$  is inserted, movement (1), in the *grooves* of  $A_1$  and  $A_2$  and then it is pushed downward, movement (2), in  $B_1$  and  $B_2$ , Fig. 34,
- D is inserted in the *grooves* of  $A_1$  and  $A_2$ , sliding on  $C_2$ , Fig. 35-36.

The most significant **advantages** of the present invention are:

- The system in object allows to make countless artefacts.
- The built up artefacts are held firm.
- The field of applications is wide and various.
- The employed materials are various and in mixed type.

- The work processing requested is very short.
- The employed machines and labour are minimum.
- The cost of production is extremely reduced.
- The dimensions of packing and storage are reduced.
- The assembling-disassembling of the artefacts is simple and quick.
- The rejected items are considerably reduced.

## BRIEF DESCRIPTION OF DRAWINGS

Fig. 1: Minimal cubic *box structure* with a *multiple wall* built up with one *primary plate* and one *secondary plate*.

Fig. 2: *Structure* in a *parallelepiped* shape.

Fig. 3: *Structure* with six *multiple walls*.

Fig. 4: *Structure* with *walls* in a *frame shape*.

Fig. 5: *Structure* with *extended walls*.

Fig. 6: *Multiple wall* built up with two *plates*.

Fig. 7: *Multiple wall* built up with three *plates*.

Fig. 8: *Primary plate*; *pilaster strip* (a), *groove* (b), *rib* (c).

Fig. 9: *Secondary plate* in its *simplest* shape.

Fig. 10: Portion of *groove* (a); *stiffening fold* (b).

Fig. 11: *Secondary plate modelled* in its thickness.

Fig. 12: *Secondary plate* with an incremented thickness to fill in the empty room in the protruding of the *pilaster strips*.

Fig. 13: Portions of *grooves* (c,g); *internal* (d,e) and *external* (f,h,i,n) *modellings* to the perimeter; portions of *ribs* (i,m).

Fig. 14: *Frame plate*; *internal* (a) and *external* (b) *ribs*.

Fig. 15: *Plate extended* beyond the *grooves*.

Fig. 16: *Prefabricated plate*.

Fig. 17: *Prefabricated plate* in a *frame shape*.

Fig. 18: *Complementary plates* (a,b), in which all *walls* have the same thickness; *supplementary plates* (c,d), in which the total thickness of the *multiple wall* is bigger than the other *walls*.

Fig. 19: Example of substitutive *elements* of the *secondary plate* and a modified *primary plate* (e).

Fig. 20: Example of substitutive *elements* of the *secondary plate*, and a modified *groove* of the *primary plate* (f).

Fig. 21: Example of a substitutive *device* of the *secondary plate*, made with two *fly springs* (g).

Fig. 22 and 23: Width of the *groove*, equal to the thickness of the *wall* which it has to receive.

Fig. 24: Depth (D) of the *groove*, equal to the *secondary plate* thickness (T).

Fig. 25: Example of a substitutive *device* of the *groove*.

Fig. 26: *Primary plate* with *folds*.

Fig. 27: *Prefabricated plate* in a *folded shape*.

Fig. 28: *Prefabricated frame plate* in a *folded shape*.

Fig. 29: Inner length (L) =  $(W+T_1+T_2+T_n)$  of a *folded primary plate*.

Fig. 30: Example of a substitutive *device of the fold*.

Fig. 31, 32, 33, 34, 35, 36: *Procedure of assembling structures*.

Fig. 37: *Cubic structure* built up with twelve identical *grooved plates*.

Fig. 38: *Cubic structure* built up with twelve identical *folded plates* with *folds* cut at their *edges*.

Fig. 39: *Stackable structure* with *pilaster strips* cut at their *edges*.

Fig. 40: A small table built up with *plates* (d,e,f), obtained by cutting them, one into the other, from the same sheet, that is equal both to the plate (c) and to the glass *secondary plate* (b).

Fig. 41: A library module built up with *plates* jointed both with the internal and the external *ribs*, using two *secondary plates*, in which disassembled and stacked *plates* (h,i,l,m), make a parallelepiped (g).

Fig. 42: A box with an access *hole* on a *primary plate* and with a *secondary plate* working as a *sliding lid*.

Fig. 43: A box with one holed *multiple wall* and with a blocking lid obtained by rejected items from the holing of two *plates* of *multiple wall*.

Fig. 44: An example of fixing *device*: *fly spring* (a) that allows the (secret) opening of the box through a *pin* (b).

Fig. 45: An example of fixing *device*: a classic *padlock*.

Fig. 46: An armchair built up extending the *walls* of the *structure*.

Fig. 47: A complex *structure* composed by several *structures* joined together by the extension of the *primary plates*.

## BEST MODES FOR CARRYING OUT THE INVENTION

The generic minimal structure, built up with seven plates, is suitable for building many kinds of boxes and countless artefacts.

Among the possible configurations of the present invention the followings are the preferred.

- *Structures* in which the *secondary plates* are *complementary* to their *primary plates*; so all *single* and *multiple walls* have an equal thickness and all *grooves* have an equal width, Fig. 18 (a,b).

This solution has an aesthetical character.

- *Structures* wherein the *secondary plates* are *supplementary* to their *primary plates*; so all *primary plates* have an equal thickness, the *multiple walls* are thicker than the *single walls* and the *grooves* receiving *multiple walls* are wider than the other ones, Fig. 18 (c,d).

This practical solution is suitable for small tables, trolleys, etc., wherein the *secondary plate* is a glass shelf, Fig 40.

- *Cubic structure*, built up with twelve perfectly identical *grooved plates* and coupled pair wise with matching ungrooved faces, Fig 37.

This configuration is suitable for a witty game.

- *Cubic structure*, built up with twelve perfectly identical *plates*, provided with *folds* shortened at their edges in measure equal to their depth, coupled pair wise with matching unfolded faces, Fig 38.

Also this configuration is suitable for a witty game.

- *Stackable structures* wherein *plates edges* are reduced in measure equal to the *grooves* depth, Fig. 39.

This configuration allows stacking several structures.

- *Structures* containing *frame plates*, wherein the *grooves* are jointed also on the internal *ribs* of *plates*, and wherein at least two *secondary plates* are employed, Fig 41.

This way is suitable for trolleys, showcases, bookshelves, etc.

- *Structures* having a *primary plate* provided with an *access hole* and with a *secondary plate* working as a *sliding lid*, Fig. 42.

This is a practical solution for boxes.

- *Structures* having an *access hole* and a *blocking lid* obtained by the two, one smaller than the other, holing rejected items of the two *plates* of the *multiple wall*, Fig. 43.

Also this is a practical solution for boxes.

- *Multiple walls* supplied by a definitively *fixing device* like a *fly spring*, Fig. 44, a *padlock*, Fig. 45, a *clip*, a *screw*, etc.

These are useful complements.

- *Nodal structure* wherein *walls* are extended beyond the shut box part, Fig.46

This configuration is suitable making chairs, armchairs, etc.

- *Multiple nodal structures*, composed by many *structures* joined together by the extension of the *primary plates*, provided by other couples of *grooves*, employing several *secondary plates*, Fig. 47.

This configuration is suitable for building complex structures.

## INDUSTRIAL APPLICABILITY

The following list of industrial products that can be built up by the system in object and most part of them are composed with only seven elements simply jointed them together.

Boxes of any types. Cases. Ballot boxes. Witty games. Tanks. Containers. Aquariums. Kennels. Cages. Prefabricated houses. Structures in wood, plastic, metal, glass, concrete, stone. Modular walls. Basements. Platforms. Bookcases. Showcases. Stands. Tables. Small tables. Trolleys. Trunks. Chairs. Pouffes. Benches. Lamps. Closets. Cabinet.

Moreover, if plywood is used, the invention can be carried out employing only a pantograph, which allows to get the finished product

In this case it is possible to obtain all plates of the same artefact cutting one piece inside the other from one single sheet of material.