

(No Model.)

2 Sheets—Sheet 1.

# J. L. SHELTON. WATER WHEEL.

No. 429,780.

Patented June 10, 1890.

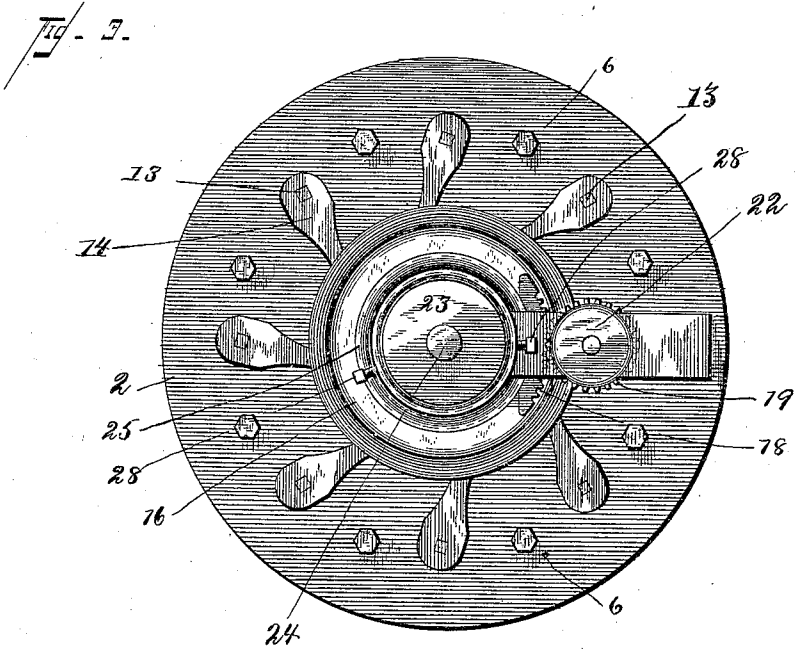
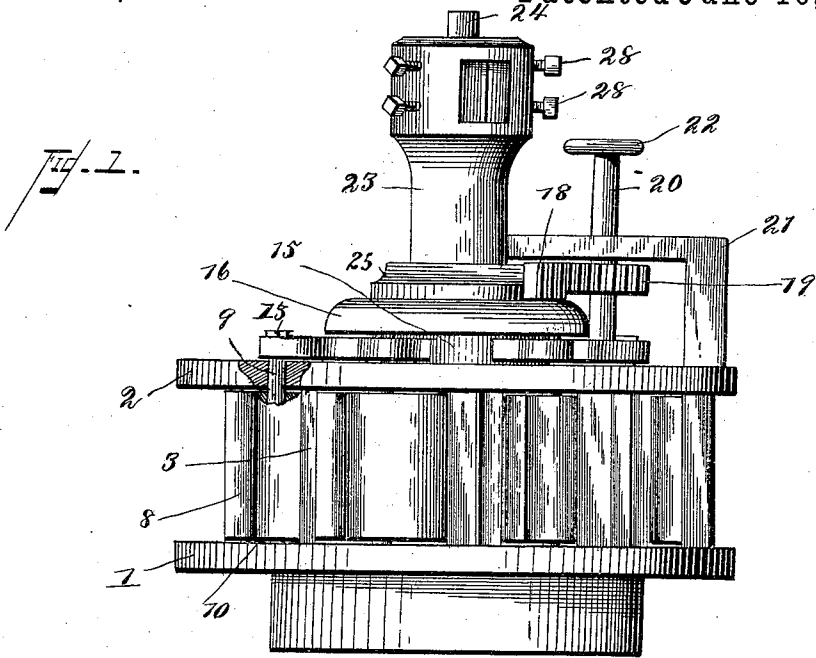

Witnesses:  
*F. L. Orland*

Inventor

**JAMES L. SHELTON.**

By his Attorneys,

*M. S. Dwall*

*C. Snow & Co.*

(No Model.)

2 Sheets—Sheet 2.

# J. L. SHELTON. WATER WHEEL.

No. 429,780.

Patented June 10, 1890.

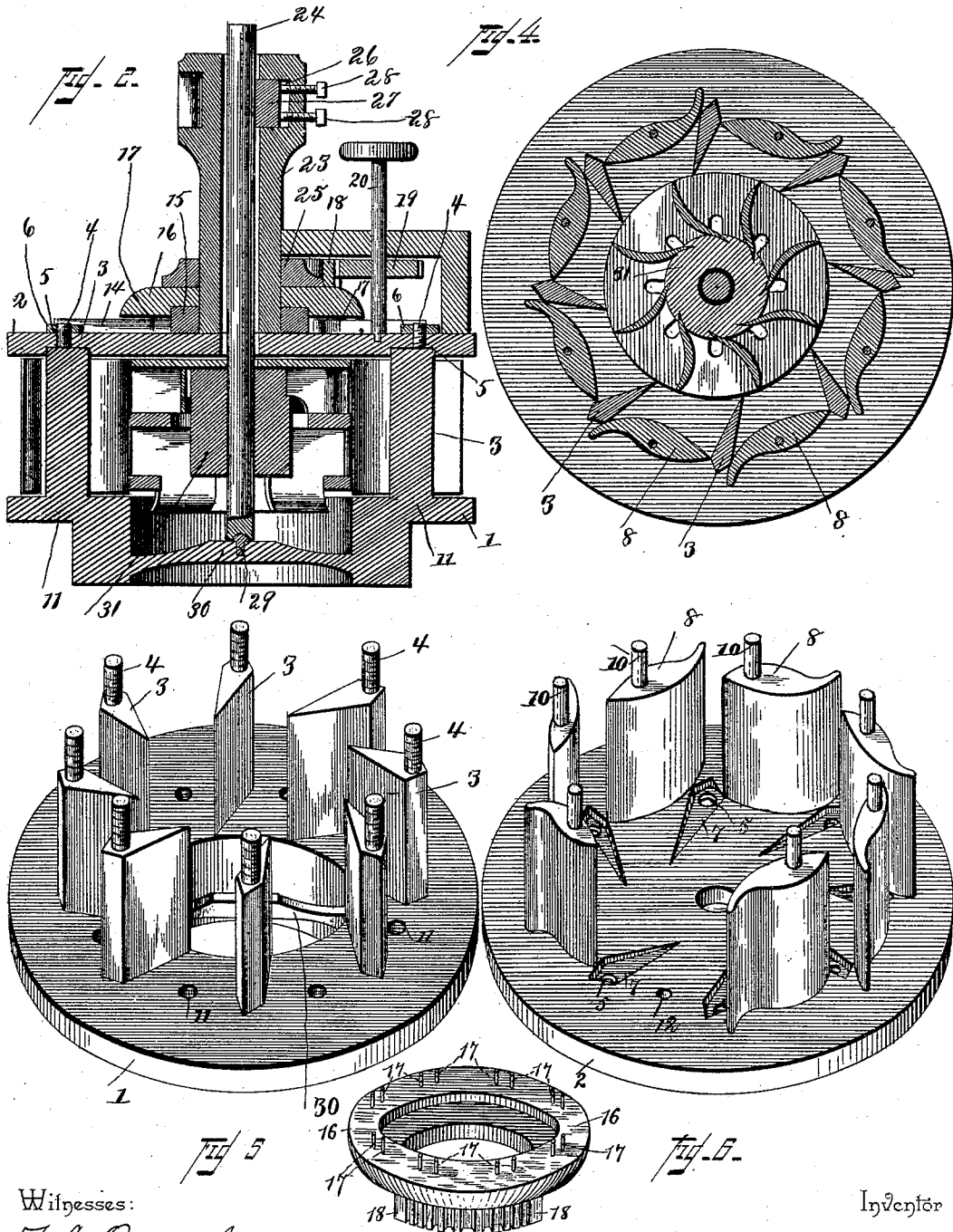

Witnesses:

*F. L. Ourand*

*W. S. Davall*

Inventor

**JAMES L. SHELTON.**

By *his* Attorneys,  
*Chas. Snow & Co.*

# UNITED STATES PATENT OFFICE.

JAMES LEE SHELTON, OF INEZ, VIRGINIA.

## WATER-WHEEL.

SPECIFICATION forming part of Letters Patent No. 429,780, dated June 10, 1890.

Application filed February 25, 1890. Serial No. 341,715. (No model.)

*To all whom it may concern:*

Be it known that I, JAMES LEE SHELTON, a citizen of the United States, residing at Inez, in the county of Louisa and State of Virginia, have invented a new and useful Water-Wheel, of which the following is a specification.

This invention relates to that class of water-wheels which are known as "turbines;" and it has for its object to construct a wheel of this class which shall be simple, durable, and efficient, and in which the gates whereby the quantity of water admitted to the wheel is regulated may be absolutely controlled or the water cut off when desired without excessive strain upon the working parts of the mechanism.

With these ends in view the invention consists in the improved construction, arrangement, and combination of parts, which will be hereinafter fully described, and particularly pointed out in the claims.

In the drawings hereto annexed, Figure 1 is a side elevation of a turbine embodying my improvements. Fig. 2 is a vertical sectional view of the same. Fig. 3 is a top view. Fig. 4 is a horizontal sectional view. Fig. 5 is a perspective detail view of the lower part of the casing. Fig. 6 is a perspective view showing the upper part of the casing in an inverted position. Fig. 7 is a bottom perspective of the gate-operating ring.

Like numerals of reference indicate like parts in all the figures.

The casing of my improved turbine is composed of the bottom and top plates, designated, respectively, by 1 and 2. Cast or formed integrally with the lower plate or section 1 are a series of upwardly-extending guide-plates 3 3, provided at their corners with upwardly-extending screw-threaded pins 4, extending through perforations 5 in the top plate, and having the nuts 6, whereby the bottom and top plates are secured firmly together. The top plate is also provided on its under side with grooves 7, to receive the upper ends of the guides 3, which are thus secured very firmly, and enable the several parts to be connected very rigidly and securely.

8 8 designate the gates, which are curved or sigmoidal in horizontal section, so as to be adapted to fit closely and tightly against the guides 3, between which they are pivoted.

The upper and lower edges of the gates 8 are provided with centrally-located pivotal pins 9 and 10, the latter of which are journaled in sockets 11 in the base-plate 1, while the former extend through perforations 12 in the top plate of the casing and terminate in squared posts 13, upon which the operating-levers 14 are mounted.

The top plate 2 is provided with a central box or projection 15, upon which is mounted a ring 16, under which the inner ends of the operating-levers 14 are extended. Said ring 16 is provided with downwardly-extending pins 17, fitting against opposite sides of the inner ends of each of the operating-levers, which may thus, by simply turning or rotating the ring 16, be operated to adjust the case. The ring 16 is provided on its upper side with a segmental rack 18, engaging a pinion 19, which is mounted upon a short shaft 20, journaled in a socket in the top plate of the casing and in a bracket 21. The said shaft is provided at its upper end with a hand-wheel 22, by means of which it may be conveniently manipulated for the purpose of operating and adjusting the gates.

23 represents an upright or pedestal, which is screwed into or suitably mounted centrally upon the top plate of the casing. Said pedestal, which forms the bearing for the shaft 24 of the water-wheel, is provided with an annular flange or collar 25, which serves to confine the ring 16 in its operative position. The upper end of the pedestal is provided with interior sockets or recesses 26, in which are located radially-sliding blocks 27, adapted to be forced by means of set-screws 28 into contact with the shaft 24, for the purpose of centering the latter and holding it in a true vertical position, and also for the purpose of compensating for wear.

The lower end of the shaft 24 is journaled upon a gudgeon 29, extending upwardly from a bridge-piece 30, extending diametrically across the opening in the bottom plate of the casing. Said shaft carries the wheel 31, which is composed of two tiers of buckets, suitably connected to the hub of said wheel and braced or connected at their outer edges by means of suitable rings or bands.

The operation and advantages of this invention will be readily understood from the

foregoing description, taken in connection with the drawings hereto annexed. The quantity of water admitted to the wheel may be perfectly controlled by means of the gates, which may be operated in the manner described, and the strain upon which is greatly reduced, owing to the fact that the said gates are pivoted centrally, and not at their corners, as is usually the case in wheels of this class. The peculiar shape of the gates and of the guides will guide the water toward the wheel in a series of spiral currents, which is found very effective in increasing the momentum and power of the wheel.

The detailed construction of the casing, as herein described, insures strength and durability, and my improved turbine may be constructed at a nominal expense.

Having thus described my invention, I claim—

1. In a turbine, the herein-described casing, comprising the bottom plate having the guides formed integrally therewith, extending upwardly therefrom, and provided at their corners with screw-threaded pins, in combination with the top plate having grooves and perforations to receive the upper edges of the

guides and the screw-threaded pins of the latter, and the connecting-nuts, substantially as set forth.

2. The combination of the casing having the guides of the pivoted gates, the operating-levers mounted upon the upwardly-extending pivoting-pins of said gates, the boss formed centrally upon the top plate of the casing, the ring supported upon said boss and having downwardly-extending pins engaging the inner ends of the operating-levers, the pedestal mounted centrally upon the top plate of the casing and having a flange bearing against the upper side of the said ring, a segmental rack mounted upon the latter, and a pinion mounted upon a shaft journaled in the top plate of the casing and in a suitably-arranged bracket and engaging the said segmental rack, substantially as and for the purpose set forth.

In testimony that I claim the foregoing as my own I have hereto affixed my signature in presence of two witnesses.

JAS. LEE SHELTON.

Witnesses:

Z. H. MEREDITH,

M. H. LLOYD.