

(19) World Intellectual Property Organization
International Bureau



(43) International Publication Date
14 August 2008 (14.08.2008)

PCT

(10) International Publication Number
WO 2008/098097 A1

- (51) International Patent Classification:
A45C 11/04 (2006.01) A61L 2/00 (2006.01)
- (21) International Application Number:
PCT/US2008/053251
- (22) International Filing Date: 7 February 2008 (07.02.2008)
- (25) Filing Language: English
- (26) Publication Language: English
- (30) Priority Data:
60/888,605 7 February 2007 (07.02.2007) US
- (71) Applicant (for all designated States except US): **ATRION MEDICAL PRODUCTS, INC.** [US/US]; 1426 Curt Francis Road, P.o.box 564, Arab, AL 35016 (US).
- (72) Inventors; and
- (75) Inventors/Applicants (for US only): **KANNER, Rowland, W.** [US/US]; 3600 Wyeth Drive, Guntersville, AL
- (74) Agents: **GIANGIORGI, Richard, A.** et al.; Trexler, Bushnell Giangiorgi Blackstone & Marr, Lt, d., 105 West Adams Street, 36th Floor, Chicago, IL 60603 (US).
- (81) Designated States (unless otherwise indicated, for every kind of national protection available): AE, AG, AL, AM, AO, AT, AU, AZ, BA, BB, BG, BH, BR, BW, BY, BZ, CA, CH, CN, CO, CR, CU, CZ, DE, DK, DM, DO, DZ, EC, EE, EG, ES, FI, GB, GD, GE, GH, GM, GT, HN, HR, HU, ID, IL, IN, IS, JP, KE, KG, KM, KN, KP, KR, KZ, LA, LC, LK, LR, LS, LT, LU, LY, MA, MD, ME, MG, MK, MN, MW, MX, MY, MZ, NA, NG, NI, NO, NZ, OM, PG, PH, PL, PT, RO, RS, RU, SC, SD, SE, SG, SK, SL, SM, SV, SY, TJ, TM, TN, TR, TT, TZ, UA, UG, US, UZ, VC, VN, ZA, ZM, ZW.
- (84) Designated States (unless otherwise indicated, for every kind of regional protection available): ARIPO (BW, GH, GM, KE, LS, MW, MZ, NA, SD, SL, SZ, TZ, UG, ZM,

[Continued on next page]

(54) Title: IMPROVED CONTACT LENS CASE

FIG. 4

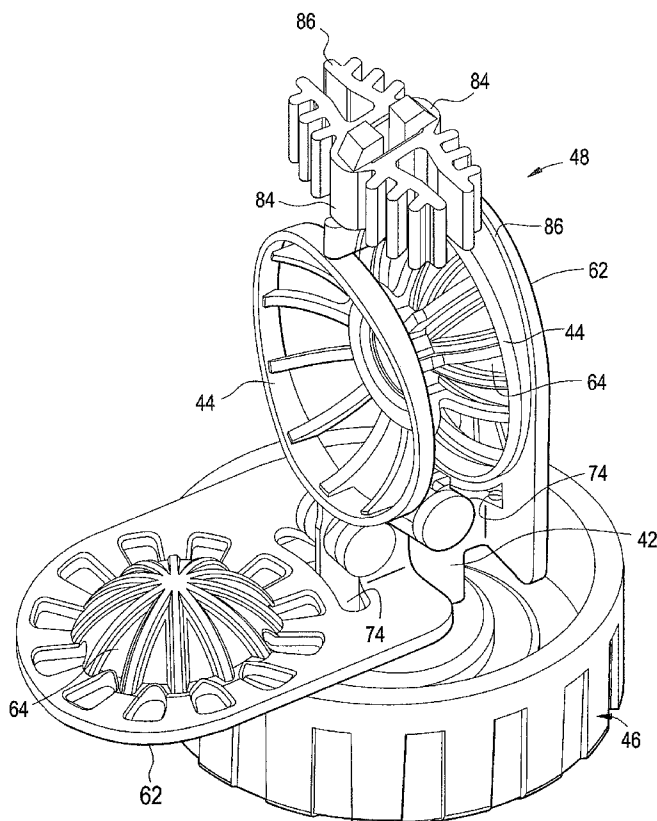

(57) Abstract: An improved contact lens case (40, 140) which includes domes (64, 164) that are provided on hinged members (62, 162). Preferably, the contact lens case (40, 140) is configured to efficiently utilize space and volume such that no more than 10 cc's of contact lens solution are required to disinfect contact lenses in the case (40, 140). The hinged members (62, 162) are preferably non-planar which allows the domes (64, 164) to be provided on the hinged members (62, 162), and allows the use of deep larger diameter, back-to-back cages (44, 144) on the stem (42, 142), without having to resort to using more than 10 cc's of fluid to immerse contact lenses that are disposed on the domes (64, 164), between each of the domes (64, 164) and a respective cage (44, 144). Each of the hinged members (62, 162) has a cylindrically-curved shell form in which the axis of its curve is approximately parallel to the central axis of the central planar stem member (42, 142).

WO 2008/098097 A1



ZW), Eurasian (AM, AZ, BY, KG, KZ, MD, RU, TJ, TM),
European (AT, BE, BG, CH, CY, CZ, DE, DK, EE, ES, FI,
FR, GB, GR, HR, HU, IE, IS, IT, LT, LU, LV, MC, MT, NL,
NO, PL, PT, RO, SE, SI, SK, TR), OAPI (BF, BJ, CF, CG,
CI, CM, GA, GN, GQ, GW, ML, MR, NE, SN, TD, TG).

— *with information concerning one or more priority claims
considered void*

Date of publication of the amended claims: 11 December 2008

Published:

- *with international search report*
- *with amended claims*

AMENDED CLAIMS
received by the International Bureau on
16 September 2008 (16.09.08)

What is claimed is:

1. A contact lens case characterized by: a cup; a cap which engages the cup; a stem which extends from the cap, wherein the stem has two cages thereon; two pivotable members engaged with the stem and having domes thereon, said pivotable members pivotable between an open position and a closed position, wherein the pivotable members have support ears which are spaced apart from each other, wherein the contact lens case is configured such that the pivotable members provide a detenting force as a result of outward deflection of the support ears, and wherein the support ears deflect away from each other and come back toward each other as the pivotable members are moved between their closed position and their open position.
2. A contact lens case as recited in claim 1, characterized in that the contact lens case is configured such that elastic properties of the pivotable members provide a detenting force which retains the pivotable members in position relative to the stem.
3. A contact lens case as recited in claim 1, characterized in that the stem has receptacles which receive the support ears, wherein the support ears are insertable in the receptacles when the pivotable members are in the closed position.
4. A contact lens case as recited in claim 1, characterized in that the cages are back-to-back on the stem.
5. A contact lens case as recited in claim 1, characterized in that each of the pivotable members has a portion which surrounds the domes and is which non-planar, said portion providing that the pivotable members have convex

AMENDED SHEET (ARTICLE 19)

sides which face each other when the pivotable members are in their closed positions.

6. A contact lens case as recited in claim 5, characterized in that the pivotable members are cylindrically-curved.
7. A contact lens case as recited in claim 1, characterized in that the pivotable members mount and pivot within receptacles that are disposed on the stem.
8. A contact lens case as recited in claim 1, characterized in that each of the pivotable members has a slot interruption to allow flushing of fluid.
9. A contact lens case as recited in claim 1, characterized in that the stem has an internal vent port.
10. A contact lens case as recited in claim 6, characterized in that each of the pivotable members has a pair of hinge pins which are disposed in the receptacles on the stem.
11. A contact lens case as recited in claim 10, characterized in that each of the receptacles on the stem has a receiving slot for receiving the hinge pins such that the hinge pins seat in a bore in the receptacle.
12. A contact lens case as recited in claim 6, further characterized by a detent cam surface which is disposed in at least one of the receptacles, wherein at least one of the hinge pins of the pivotable members is configured to engage the detent cam surface in the receptacle, thereby providing a latch feature wherein the pivotable members tend to stay in position.
13. A contact lens case as recited in claim 1, characterized in that the pivotable members and the stem are configured to provide a detent feature which holds the pivotable members in a closed position.

14. A contact lens case as recited in claim 1, characterized in that the pivotable members and the stem are configured to provide a detent feature which holds the pivotable members in an open position.
15. A contact lens case as recited in claim 1, characterized in that the pivotable members and the stem are configured to provide a detent feature which holds the pivotable members in both an open and a closed position.
16. A contact lens case as recited in claim 1, having a fused in place sealing gasket with an integrally formed pressure venting membrane within the cap.
17. A contact lens case as recited in claim 1, further characterized by a vent membrane disposed in the cap, wherein the vent membrane has a vent hole and the cap has a post which inserts in the vent hole in the vent membrane, thereby sealing the vent hole but allowing venting from the contact lens case as a result of the vent membrane moving away from the post of the cap.
18. A contact lens case as recited in claim 17, characterized in that a thermoplastic elastomer is overmolded on the cap such that the thermoplastic elastomer is integral with the vent membrane.
19. A contact lens case as recited in claim 1, characterized in that the stem is configured to engage and retain a catalyst thereon.
20. A contact lens case as recited in claim 19, characterized in that the catalyst has a short side which is aligned with the pivotable members and a long side which is perpendicular to the pivotable members.
21. A contact lens case as recited in claim 6, characterized in that each of the receptacles has a cam surface on a face of the receptacle, and each pivotable member has at least one cam follower which is configured to ride along the

- cam surface.
22. A contact lens case as recited in claim 21, characterized in that each cam surface comprises a plurality of V-shaped cam notches and a plurality of ramps.
23. A contact lens case as recited in claim 22, characterized in that the ramps provide that the cam follower tends to remain in a notch once the cam follower is in the notch, unless the pivotable member is pivoted by a user.
24. A contact lens case as recited in claim 6, characterized in that each of the receptacles has a cam surface on a face of the receptacle, and each pivotable member has ears that have cam followers thereon, proximate the hinge pin.
25. A contact lens case characterized by: a cap; a cup; a thermoplastic elastomer on the cap which seals with the cup at a cap-to-cup interface and which comprises a vent membrane having a vent hole which is spaced away from the cap-to-cup interface, wherein the cap has a post which inserts in the vent hole, thereby sealing the vent hole but allowing venting from the contact lens case as a result of the vent membrane moving away from the post of the cap.
26. A catalyst for a contact lens case characterized by: a body having a center hole, wherein the body is elliptical and has a major axis and a minor axis.
27. A contact lens case as recited in claim 1, characterized in that the stem has receptacles which receive the support ears, and the support ears are configured to function as cam followers in the receptacles when the pivotable members are pivoted.

28. A contact lens case as recited in claim 1, characterized in that the stem has receptacles which receive the support ears, and the support ears have a planar wall which is configured to slide into openings in the receptacles.
29. A contact lens case as recited in claim 1, characterized in that the stem has receptacles which receive the support ears, and the support ears are configured to function as hinge pins once they are captured in the receptacles.