

(19) World Intellectual Property
Organization
International Bureau



(43) International Publication Date
1 December 2005 (01.12.2005)

PCT

(10) International Publication Number
WO 2005/114309 A1

(51) International Patent Classification⁷: G02F 1/13

(21) International Application Number:
PCT/IB2005/051585

(22) International Filing Date: 16 May 2005 (16.05.2005)

(25) Filing Language: English

(26) Publication Language: English

(30) Priority Data:
60/573,242 21 May 2004 (21.05.2004) US

(71) Applicant (for all designated States except US): KONINKLIJKE PHILIPS ELECTRONICS, N.V. [NL/NL]; Groenewoudseweg 1, NL-5621 BA Eindhoven (NL).

(71) Applicant: U.S. PHILIPS CORPORATION [US/US]; 1251 Avenue of the Americas, New York, NY 10020 (US).

(72) Inventors; and

(75) Inventors/Applicants (for US only): LAFARRE, Raymond W. L. [NL/NL]; Groenewoudseweg 1, NL-5621 BA Eindhoven (NL). RENS, Bas J. E. [NL/NL]; Groenewoudseweg 1, NL-5621 BA Eindhoven (NL).

(74) Common Representative: KONINKLIJKE PHILIPS ELECTRONICS, N.V.; c/o Keegan Frank, P.O. Box 3001, Briarcliff Manor, New York, NY 10510-8001 (US).

(81) Designated States (unless otherwise indicated, for every kind of national protection available): AE, AG, AL, AM, AT, AU, AZ, BA, BB, BG, BR, BW, BY, BZ, CA, CH, CN, CO, CR, CU, CZ, DE, DK, DM, DZ, EC, EE, EG, ES, FI, GB, GD, GE, GH, GM, HR, HU, ID, IL, IN, IS, JP, KE, KG, KM, KP, KR, KZ, LC, LK, LR, LS, LT, LU, LV, MA, MD, MG, MK, MN, MW, MX, MZ, NA, NG, NI, NO, NZ, OM, PG, PH, PL, PT, RO, RU, SC, SD, SE, SG, SK, SL, SM, SY, TJ, TM, TN, TR, TT, TZ, UA, UG, US, UZ, VC, VN, YU, ZA, ZM, ZW.

(84) Designated States (unless otherwise indicated, for every kind of regional protection available): ARIPO (BW, GH, GM, KE, LS, MW, MZ, NA, SD, SL, SZ, TZ, UG, ZM, ZW), Eurasian (AM, AZ, BY, KG, KZ, MD, RU, TJ, TM), European (AT, BE, BG, CH, CY, CZ, DE, DK, EE, ES, FI, FR, GB, GR, HU, IE, IS, IT, LT, LU, MC, NL, PL, PT, RO, SE, SI, SK, TR), OAPI (BF, BJ, CF, CG, CI, CM, GA, GN, GQ, GW, ML, MR, NE, SN, TD, TG).

Declarations under Rule 4.17:

— as to applicant's entitlement to apply for and be granted a patent (Rule 4.17(ii)) for the following designations AE, AG, AL, AM, AT, AU, AZ, BA, BB, BG, BR, BW, BY, BZ, CA, CH, CN, CO, CR, CU, CZ, DE, DK, DM, DZ, EC, EE, EG, ES, FI, GB, GD, GE, GH, GM, HR, HU, ID, IL, IN, IS, JP, KE, KG, KM, KP, KR, KZ, LC, LK, LR, LS, LT, LU, LV, MA, MD, MG, MK, MN, MW, MX, MZ, NA, NG, NI, NO,

[Continued on next page]

(54) Title: ROLLABLE DISPLAY DEVICE WITH STRAIN REDUCTION

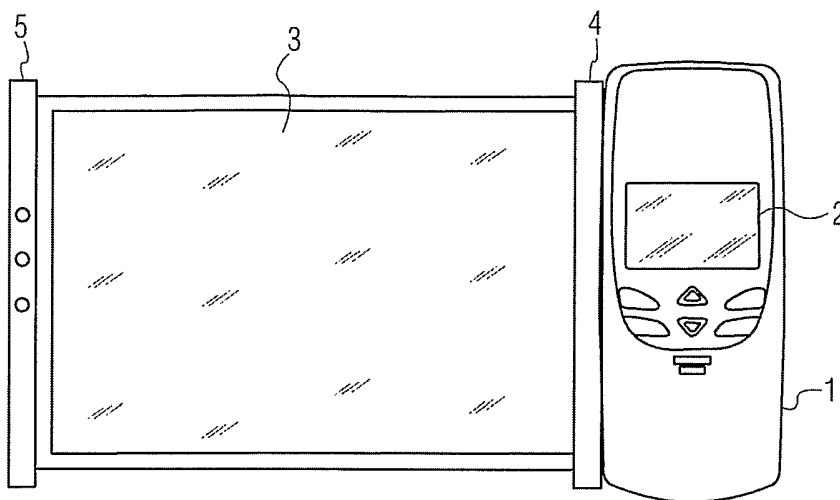

(57) Abstract: A rollable display device including an inner housing (102) having an inner slot (108), a rollable display (106) having a bend portion (118), which is disposed through the inner slot (108), and a strain reducer (100) operably connected to the rollable display (106) to reduce strain at the bend portion (118). The strain reducer (100) acts by increasing radius of the bend portion (31), locating a neutral line of the rollable display (106) at a selected layer of the bend portion (31), and/or reducing cycling of the bend portion (31).

WO 2005/114309 A1



NZ, OM, PG, PH, PL, PT, RO, RU, SC, SD, SE, SG, SK, SL, SM, SY, TJ, TM, TN, TR, TT, TZ, UA, UG, UZ, VC, VN, YU, ZA, ZM, ZW, ARIPO patent (BW, GH, GM, KE, LS, MW, MZ, NA, SD, SL, SZ, TZ, UG, ZM, ZW), Eurasian patent (AM, AZ, BY, KG, KZ, MD, RU, TJ, TM), European patent (AT, BE, BG, CH, CY, CZ, DE, DK, EE, ES, FI, FR, GB, GR, HU, IE, IS, IT, LT, LU, MC, NL, PL, PT, RO, SE, SI, SK, TR), OAPI patent (BF, BJ, CF, CG, CI, CM, GA, GN, GQ, GW, ML, MR, NE, SN, TD, TG)

— as to the applicant's entitlement to claim the priority of the earlier application (Rule 4.17(iii)) for all designations

Published:

— with international search report

For two-letter codes and other abbreviations, refer to the "Guidance Notes on Codes and Abbreviations" appearing at the beginning of each regular issue of the PCT Gazette.

PHUS040226WO

ROLLABLE DISPLAY DEVICE WITH STRAIN REDUCTION

This invention relates generally to rollable display devices, and more specifically to
5 rollable display devices with strain reduction.

Miniaturization and increased processing power has recently allowed great increases in the portability of electronics. Complex devices have been reduced to pocket size. Consumers are able to carry and use wherever they desire such devices as cellular telephones, music players, game players, still and motion digital cameras, and GPS locators. Still, the size and
10 form factor of the devices is often limited by the optical display because most devices currently use an inflexible glass optical display. Such displays are bulky, fragile, and difficult to replace when damaged.

To obtain even greater portability and avoid the drawbacks of glass optical displays, rollable displays have been developed. **FIG. 1** is a front view of an exemplary use of a rollable
15 display as disclosed in International Publication Nos. WO 2004/001704 A1 and WO 2004/031927 A2 to Bas J. E. van Rens, both entitled "Apparatus with Display" and both incorporated herein by reference in their entirety. In this embodiment, a rollable display **3** is unrolled from a housing **4,5** into the usable position illustrated. The mobile telephone **1** provides the input to the rollable display **3**. In an alternative embodiment, the electronics
20 providing the input to the rollable display, such as the mobile telephone or other electronics, is enclosed in one of the housings.

FIG. 2 is a cross section view of a rollable display device. The rollable display device **10** includes an inner housing **12**, such as an inner cylinder, housing the electronics **14**, and an outer housing **16**, such as an outer cylinder, disposed about the inner housing **12**. The wall of
25 the inner housing **12** forms an inner slot **13** and the wall of the outer housing **16** forms an outer slot **17**. A rollable display **18** includes a connection portion **20**, a bend portion **22**, a rolled portion **24**, and an external portion **26**. The rollable display **18** is connected to the electronics **14** by the connection portion **20**, passes through the inner slot **13** at the bend portion **22**, wraps around the inner housing **12**, and exits the outer housing **16** at the external
30 portion **26**. In operation, the rollable display **18** is deployed for use by extending the rolled portion **24** through the outer slot **17**. The rolled portion **24** is extended and retracted manually or by motor power.

- 2 -

One problem with rollable display devices is that the repetitive strain of rolling and unrolling the rollable display for use damages the rollable display. The rolled portion **24** typically makes a gradual, large-radius curve around the inner housing **12**, so the stress and resulting strain is limited below a design threshold, preventing damage. A radius greater than 7 millimeters for a 100 μ meter thick rollable display typically holds strains in the electrically active region of the rollable display below a 1 percent limit. However, the sharp bending of the display **18** at the bend portion **22** exceeds the design threshold and damages the rollable display **18** over time from repetitive strain. Examples of display failures include broken circuits, layer delamination, cracking, and buckling. Such failures may prevent the rollable display from rolling and unrolling, may reduce the image quality of the rollable display, or may prevent the rollable display from functioning. Excessive strain in the bend portion **22** may also interfere with the connection of the rollable display **18** to the electronics **14** at the connection portion **20**.

FIG. 3 is a cross section view of a portion of a rollable display. In the example shown, the rollable display **30** includes a first layer **32**, a second layer **34**, and a third layer **36**. Typically, the layers are laminated together to form the rollable display **30**. The first layer **32** is typically a substrate for supporting the much thinner second layer **34**, which is typically a fragile electronics layer. The third layer **36** is typically an electronic ink layer responsive to electrical charge from the second layer **34** to display text or graphical information to the user. The rollable display **30** has a neutral line **38**, which is free of stress when the rollable display **30** is bent, such as when bending the rolled portion around the inner housing or the bend portion through the inner slot. The location of the neutral line **38** depends on the thickness and modulus of elasticity of each layer making up the rollable display **30**. When bent, the rollable display **30** is in tension on one side of the neutral line **38** and in compression on the other side. Repeated cycling of the rollable display **30** to a radius smaller than the minimum design radius can result in failure of the rollable display **30**.

It would be desirable to have a rollable display device with strain reduction that overcomes the above disadvantages.

One aspect of the present invention provides a rollable display device including an inner housing having an inner slot, a rollable display having a bend portion, which is disposed

- 3 -

through the inner slot, and a strain reducer operably connected to the rollable display to reduce strain at the bend portion.

Another aspect of the present invention provides a rollable display device including an inner housing having an inner slot, an outer housing rotatable about the inner housing, a
5 rollable display having a bend portion, which is disposed through the inner slot, and means for reducing strain of the bend portion.

Another aspect of the present invention provides a rollable display device including an inner housing having an inner slot and an opening; an outer housing rotatable about the inner
10 housing, and having an outer slot and a cavity; a rollable display disposed through the inner slot and the outer slot; a bolt slidably disposed in the opening; and a spring urging the bolt toward the outer housing; wherein the bolt is received in the cavity when a desired length of the rollable display is positioned between the inner slot and the outer slot.

The foregoing and other features and advantages of the invention will become further
15 apparent from the following detailed description of the presently preferred embodiment, read in conjunction with the accompanying drawings. The detailed description and drawings are merely illustrative of the invention rather than limiting, the scope of the invention being defined by the appended claims and equivalents thereof.

FIG. 1 is a front view of an exemplary use of a rollable display;

20 **FIG. 2** is a cross section view of a rollable display device;

FIG. 3 is a cross section view of a portion of a rollable display;

FIGS. 4 - 6 are cross section views of a bend portion of a rollable display with strain reduction made in accordance with the present invention;

FIGS. 7 & 8 are perspective views of an alternative embodiment of a rollable display
25 device with strain reduction made in accordance with the present invention;

FIG. 9 is cross section view of an alternative embodiment for an extended cavity of a rollable display device with strain reduction made in accordance with the present invention;

FIG. 10 is a top view of an alternative embodiment for an outer housing of a rollable display device with strain reduction made in accordance with the present invention;

30 **FIG. 11** is a perspective view of another alternative embodiment of a rollable display device with strain reduction made in accordance with the present invention.

- 4 -

FIGS. 4 - 6, in which like elements share like reference numbers, are cross section views of a bend portion of a rollable display with strain reduction made in accordance with the present invention. **FIG. 4** provides an example of strain reduction by increasing radius of the bend portion. **FIGS. 5 & 6** provide examples of strain reduction by location the neutral line at a selected layer of the bend portion.

Referring to **FIG. 4**, the bend portion **31** of a rollable display includes first layer **32**, second layer **34**, and third layer **36**, typically being the substrate, electronics, and electronic ink layers, respectively. In one embodiment, the electronics layer is the selected fragile layer that is most in need of protection by strain reduction. In alternative embodiments, other layers can be the selected layer. The definition of layer is not limited to discrete layers, but includes transitional layers. For example, the second layer **34** as shown can be a transition layer between the first layer **32** and third layer **36** where the first layer **32** and third layer **36** are joined by lamination, adhesive bonding, or the like. The strain reducer **40** includes channels **42** formed in the first layer **32** and the third layer **36** parallel to the central axis of the rollable display when rolled. The channels **42** act as strain reducers by thinning the rollable display at the bend portion **31**, which increases the radius of the bend at the inner slot in the inner housing. A larger bend radius reduces strain from repetitive cycling and protects the selected fragile layer from damage. In an alternative embodiment, only a single channel **42** is formed in the first layer **32** or the third layer **36**, rather than both layers, as the strain reducer **40**. In an alternative embodiment, the thickness of the channel **42** is selected to locate the neutral line of the bend portion **31** at a selected layer.

FIGS. 5 & 6 provide examples of strain reduction by location the neutral line at a selected layer of the bend portion. **FIG. 5** uses an alternative material portion in one of the layers as the strain reducer and **FIG. 6** uses an additional layer as the strain reducer.

Referring to **FIG. 5**, the strain reducer **40** includes an alternative material portion **54** disposed in the third layer **36** of the bend portion **31** parallel to the central axis of the rollable display when rolled. The material of the alternative material portion **54** is a different material than the original third layer material **52** and is selected for its modulus of elasticity so that the neutral line **38** is at the selected layer. The alternative material portion **54** can be of any desired thickness to move the neutral line **38** to the desired layer, i.e., thinner, thicker, or the

- 5 -

same thickness as the third layer material **52**. In the example shown, the neutral line **38** is located in the second layer **34** under the alternative material portion **54** and in the first layer **32** under the original third layer material **52**. The second layer **34** is typically the fragile electronics layer. Locating the neutral line at the selected layer as used herein includes locating the neutral line near the selected layer. The neutral line need not be precisely on the selected layer to effect the desired strain reduction. Strain is proportional to the distance between the selected layer and the neutral line, so any reduction in the distance provides stress reduction. In one example, effective stress reduction is provided by locating the neutral line within 20 μ meters of a 2 μ meters thick electronics layer in a 100 μ meters thick display.

The alternative material portion **54** can be made of any polymer, plastic, or other material compatible with the surrounding materials and providing the desired modulus of elasticity. Exemplary materials include polyamide, polyethylene terephthalate (PET), and the like. In one embodiment, the alternative material portion **54** is formed of a uniform material. In an alternative embodiment, the alternative material portion **54** is formed of layers of material. In another alternative embodiment, the alternative material portion **54** is formed of two or more interspersed materials, such as spheres or voids dispersed in another material. Those skilled in the art will appreciate that additional alternative material portions can be included in other layers on both or either side of the neutral line to precisely locate the neutral line.

Referring to **FIG. 6**, the strain reducer **40** includes a fourth layer **62** disposed on the third layer **36** of the bend portion **31** to locate the neutral line **38** at a selected layer of the bend portion **31**. The thickness and modulus of elasticity of the fourth layer **62** are selected to locate the neutral line **38** as desired. Locating the neutral line at the selected layer as used herein includes locating the neutral line near the selected layer. The fourth layer **62** can be formed of a single or multiple materials, in a uniform layer or in a more complex configuration, such as spheres or layers. The fourth layer **62** can be made of any polymer, plastic, or other material compatible with the surrounding materials and providing the desired modulus of elasticity. Exemplary materials include polyamide, polyethylene terephthalate (PET), and the like. Those skilled in the art will appreciate that layers can be applied on both or either side of the neutral line to precisely locate the neutral line.

- 6 -

FIGS. 7 & 8, in which like elements share like reference numbers, are perspective views of an alternative embodiment of a rollable display device with strain reduction made in accordance with the present invention. **FIGS. 7 & 8** show the strain reducer disengaged and engaged, respectively. The strain reducer maintains a desired length of the rollable display within the outer housing, reducing cycling and repetitive stress at the bend portion.

An outer housing **104** is rotatably disposed about an inner housing **102**. The inner housing **102** includes an inner slot **108** and the outer housing **104** includes an outer slot **114**. The rollable display **106** is connected to the inner housing **102** and has a bend portion **118**, which is located at the inner slot **108** of the inner housing **102** where the rollable display **106** passes through the inner housing **102**. The rollable display **106** passes through the outer slot **114** of the outer housing **104**. In operation, the rollable display **106** rolls around the inner housing **102** when the rollable display **106** is retracted into the outer housing **104**.

The strain reducer **100** includes a bolt **110** slidably disposed in an opening **112** in the inner housing **102** and a cavity **116** formed in the outer housing **104**. A spring (not shown), such as a leaf spring or a coil spring, urges the bolt **110** toward the outer housing **104**. The cavity **116** is located a first distance **101** from the outer slot **114** and the opening **112** is located a second distance **103** from the inner slot **108**. In one embodiment, the cavity **116** passes through the wall of the outer housing **104**. In an alternative embodiment, the cavity **116** passes part way into the wall of the outer housing **104**.

Referring to **FIG. 7**, the bolt **110** is depressed into the opening **112** by the rollable display **106** when the strain reducer **100** is disengaged. The rollable display **106** separates the bolt **110** from the outer housing **104**. Referring to **FIG. 8**, the rollable display **106** moves through the outer slot **114** as the rollable display **106** is deployed through the outer slot **114**. When the bolt **110** is aligned with the cavity **116**, the bolt **110** is received in the cavity **116** so that the strain reducer **100** is engaged. In one embodiment, the engaged strain reducer **100** prevents further motion of the inner housing **102** relative to the outer housing **104**. This assures that a desired length of the rollable display **106** remains within the outer housing **104**, avoiding cycling and repetitive strain on the bend portion **118**. The desired length is set by the difference between the first distance **101** and the second distance **103**. The desired length is independent of the total length of the rollable display **106**, allowing the rollable display device

- 7 -

to be used with different length rollable displays. When the rollable display 106 is retracted into the outer housing 104, the rollable display 106 urges the bolt 110 toward the opening 112.

5 **FIG. 9** is cross section view of an alternative embodiment for an extended cavity of a rollable display device with strain reduction made in accordance with the present invention. The extended cavity 122 is formed in the outer housing 104. The extended cavity 122 includes a first cavity 116 at a first distance 101 from the outer slot 114, a second cavity 132 at a third distance 121 from the outer slot 114, and a transition cavity 130 connecting the first
10 cavity 116 and the second cavity 132. The transition cavity 130 includes a bump 128 near the first cavity 116. A spring 134 urges bolt 110, which is coupled to the inner housing (not shown), toward the outer housing 104.

In operation, the bolt 110 is depressed toward the inner housing by the rollable display (not shown), until the bolt 110 is aligned with the first cavity 116 through the relative rotation
15 of the inner housing and the outer housing 104. When aligned, the bolt 110 is received in the first cavity 116 and further relative rotation impeded by the bump 128. When the bolt 110 is received in the first cavity 116, a desired length of the rollable display remains between the outer slot 114 and the inner slot (not shown) to reduce cycling of the bend portion and provide strain reduction. By applying sufficient torque between the inner housing and the
20 outer housing 104, the bolt 110 passes the bump 128, passes through the transition cavity 130, and rotates into the second cavity 132. The relative rotation of the inner housing and the outer housing 104 is stopped when the bolt 110 is received in the second cavity 132. In one embodiment, the third distance 121 is equal to the distance between the bolt 110 and the inner slot (the second distance 103 of **FIG. 8**), so that the inner slot and outer slot 114 are aligned
25 when the bolt 110 is received in the second cavity 132. Alignment of the inner slot and outer slot 114 permits removal and replacement of the rollable display. Certain configurations of the rollable display device provide electronics within the inner housing and a connection portion of the rollable display connectable to the electronics. The connection portion is detachable from the electronics when the inner slot is aligned with the outer slot 114.

30 In an alternative embodiment, the bolt 110 is coupled to a switch 124 responsive to the position of the bolt 110. The switch 124 has two or more states depending on the position of

- 8 -

the bolt **110**. In one embodiment, the switch **124** has one state when the bolt is separated from the outer housing **104** by the rollable display and another state when the bolt **110** is received in the first cavity **116**. In another embodiment, the switch **124** has yet another state
5 when the bolt **110** is received in the second cavity **132**, such as when the inner slot and outer slot **114** are aligned. In various embodiments, the state of the switch is used to control switching power to a drive motor for advancing and retracting the rollable display, switching power to the electronics within the inner housing, switching electronics operating mode, switching power to the image on the rollable display, switching power to a lock allowing
10 connection and detachment of the rollable display at the inner housing, and/or other functions of the rollable display device.

FIG. 10 is a top view of an alternative embodiment for an outer housing of a rollable display device with strain reduction made in accordance with the present invention. The bolt is not received in a cavity, but tracks in a spiral groove **140** formed on the inside wall of the
15 outer housing **104** free of the outer slot **114**. The spiral groove **140** is stopped at a first end **142** and a second end **144**. The inner housing makes a predetermined number of rotations relative to the outer housing **104**, allowing a predetermined length of the rollable display to be deployed. The first end **142** of the spiral groove **140** can be positioned to assure that a desired length of the rollable display remains within the outer housing **104**. Those skilled in the art
20 will appreciate that the location of the spiral groove **140** and the bolt can be reversed, with the spiral groove formed on the outside wall of the inner housing and the bolt operably attached to the outer housing. In an alternative embodiment, the bolt is of a fixed length, rather than being spring loaded.

FIG. 11 is a perspective view of another alternative embodiment of a rollable display
25 device with strain reduction made in accordance with the present invention. The strain reducer maintains a desired length of the rollable display within the outer housing, reducing cycling and repetitive stress at the bend portion. Aligning the outer slot **114** and the inner slot **108** allows a latch **205** to release the rollable display **106** from a display connection **212**.

An outer housing **104** is rotatably disposed about an inner housing **102**. The inner
30 housing **102** includes an inner slot **108** and the outer housing **104** includes an outer slot **114**. The rollable display **106** has a bend portion **118**, which is located at the inner slot **108** of the inner housing **102** where the rollable display **106** passes through the inner housing **102**. The

- 9 -

rollable display **106** passes through the outer slot **114** of the outer housing **104**. In operation, the rollable display **106** rolls around the inner housing **102** when the rollable display **106** is retracted into the outer housing **104**.

5 The strain reducer **100** includes a bolt **110** slidably and movably disposed in an opening **112** in the inner housing **102** and a cavity **116** formed in the outer housing **104**. A spring **201**, such as a leaf spring or a coil spring, urges the bolt **110** toward the outer housing **104**. In one embodiment, the cavity **116** passes through the wall of the outer housing **104**. In an alternative embodiment, the cavity **116** passes part way into the wall of the outer housing **104**.

10 The bolt **110** and spring **201** are operably connected to mounting **202**, which pivots about pin **210**, moving the bolt **110** along the length of the opening **112**. In one embodiment, the pin **210** and spring **201** are supported by an endcap (not shown) of the inner housing **102**. The bolt **110** is moveable from one distance to the inner slot **108** when the bolt **110** is at the end of the opening **112** away from the inner slot **108** to another distance to the inner slot **108** when

15 the bolt **110** is at the end of the opening **112** near the inner slot **108**. Spring **203** urges the mounting **202** and bolt **110** toward the end of the opening **112** away from the inner slot **108**. A foot **206** is operably connected to the mounting **202** and is aligned to engage a latch **205** of a display connection **212** to disconnect the rollable display **106**. The dashed line between the foot **206** and latch **205** indicates the path of the foot **206**.

20 The connection portion **216** of the rollable display **106** is connected to electronics (not shown) by the display connection **212**. The display connection **212** includes a connection block **214**, a clamp mechanism **204** urged toward the connection block **214** by springs (not shown), and a latch **205**. When the foot **206** engages the latch **205** and moves the clamp mechanism **204** away from the connection block **214**, the connection portion **216** of the

25 rollable display **106** is released from the display connection **212** and the rollable display **106** can be replaced. Those skilled in the art will appreciate that the display connection **212** can be any connection mechanically and/or electrically engageable with the rollable display **106** that uses a latch to release the rollable display **106**.

 In operation, the bolt **110** is depressed into the opening **112** by the rollable display **106**

30 when the strain reducer **100** is disengaged. The rollable display **106** separates the bolt **110** from the outer housing **104**. The rollable display **106** moves through the outer slot **114** as the

- 10 -

rollable display **106** is deployed through the outer slot **114**. When the bolt **110** is aligned with the cavity **116**, the bolt **110** is received in the cavity **116** so that the strain reducer **100** is engaged. The engaged strain reducer **100** resists further motion of the inner housing **102** relative to the outer housing **104** due to the resistance of the spring **203**. This assures that a desired length of the rollable display **106** remains within the outer housing **104**, avoiding cycling and repetitive strain on the bend portion **118**. The desired length is independent of the total length of the rollable display **106**, allowing the rollable display device to be used with different length rollable displays. When the rollable display **106** is retracted into the outer housing **104**, the rollable display **106** urges the bolt **110** toward the opening **112**.

Through application of additional torque between the inner housing **102** and the outer housing **104** to overcome the resistance of the spring **203**, the bolt **110** can be moved to the end of the opening **112** nearer the inner slot **108**. In this position, the outer slot **114** and the inner slot **108** are aligned allowing removal and replacement of the rollable display **106**. The foot **206** engages the latch **206**, moving the clamp mechanism **204** away from the connection block **214**, and releasing the connection portion **216** of the rollable display **106**. The rollable display **106** can be replaced with a new rollable display **106** in the display connection **212**. After replacement, the bolt **110** is rotated toward the end of the opening **112** away from the inner slot **108**, disengaging the foot **206** from the latch **206**, so that the display connection **212** connects to the connection portion **216** of the rollable display **106**.

While the embodiments of the invention disclosed herein are presently considered to be preferred, various changes and modifications can be made without departing from the scope of the invention. Those skilled in the art will appreciate that various designs are possible for the strain reducer **100**. For example, the strain reduction approaches discussed separately above can be combined to produce additional protection of the rollable display from repetitive strain. In an alternative embodiment, the bolt **110** is attached to the outer housing **104** and urged toward the inner housing **102**, which includes a cavity. The scope of the invention is indicated in the appended claims, and all changes that come within the meaning and range of equivalents are intended to be embraced therein.

CLAIMS

1. A rollable display device comprising:
an inner housing **102**, the inner housing **102** having an inner slot **108**;
a rollable display **106**, the rollable display **106** having a bend portion **118**, the bend portion **118** being disposed through the inner slot **108**; and
a strain reducer **100**, the strain reducer **100** operably connected to the rollable display **106** to reduce strain at the bend portion **118**.
2. The device of claim 1 wherein the rollable display comprises a first layer **32**, a second layer **34** disposed on the first layer **32**, and a third layer **36** disposed on the second layer **34**, and the strain reducer **40** comprises a first channel **42** formed in the third layer **36** of the bend portion **31**.
3. The device of claim 1 wherein the strain reducer **40** further comprises a second channel **42** formed in the first layer **32** of the bend portion **31**.
4. The device of claim 1 wherein the rollable display comprises a first layer **32**, a second layer **34** disposed on the first layer **32**, and a third layer **36** disposed on the second layer **34**, and the strain reducer **40** comprises an alternative material portion **54** disposed in the third layer **36** of the bend portion **31**.
5. The device of claim 1 wherein the rollable display comprises a first layer **32**, a second layer **34** disposed on the first layer **32**, and a third layer **36** disposed on the second layer **34**, and the strain reducer **40** comprises a fourth layer **62** disposed on the third layer **36** of the bend portion **31**.
6. The device of claim 1 further comprising an outer housing **104** rotatable about the inner housing **102**, the outer housing **104** having an outer slot **114**, the rollable display **106** being disposed through the outer slot **114**;

- 12 -

wherein the strain reducer **100** comprises a first cavity **116** formed in the outer housing **104** at a first distance from the outer slot **114**, a bolt **110** located at a second distance from the inner slot **108** and urged toward the outer housing **104**;

wherein the bolt **110** is received in the first cavity **116** when the bolt **110** is aligned with the first cavity **116**, and the difference between the first distance **101** and the second distance **103** provides a desired length of the rollable display **106** between the inner slot **108** and the outer slot **114** when the bolt **110** is aligned with the first cavity **116**.

7. The device of claim 5 further comprising a switch **124** responsive to position of the bolt **110**.

8. The device of claim 6 wherein the switch **124** is used to switch a device function selected from the group consisting of drive motor power, electronics power, electronics operating mode, rollable display image power, and rollable display connection.

9. The device of claim 5 wherein the rollable display **106** urges the bolt **110** toward the inner housing **102** when the bolt **110** is not aligned with the first cavity **116**.

10. The device of claim 5 further comprising a second cavity **132** formed in the outer housing **104** at a third distance from the outer slot **114**, and a transition cavity **130** formed in the outer housing **104** between the first cavity **116** and the second cavity **132**.

11. The device of claim 9 wherein the second distance and the third distance are equal.

12. The device of claim 9 wherein the inner housing **102** further comprises electronics **14**, and the rollable display **106** further comprises a connection portion **20** connectable to the electronics **14**, wherein the connection portion **20** is detachable from the electronics **14** when the inner slot **108** is aligned with the outer slot **114**.

- 13 -

13. The device of claim 9 further comprising a switch responsive to movement of the bolt **110**, the switch having a first state when the bolt **110** is received in the first cavity **116** and a second state when the bolt **110** is received in the second cavity **132**.

14. The device of claim 5 wherein the bolt **110** is moveable to a third distance from the inner slot **108**, the inner slot **108** being aligned with the outer slot **114** when the bolt **110** is at the third distance.

15. The device of claim 13 further comprising a foot **206** operably connected to the bolt **110**, a display connection **212** adapted to receive a connection portion **216** of the rollable display **106** and having a latch **205**, wherein the foot **206** is operable to engage the latch **205** and release the connection portion **216** from the display connection **212** when the inner slot **108** is aligned with the outer slot **114**.

16. The device of claim 1 further comprising an outer housing **104** rotatable about the inner housing **102**;

wherein the strain reducer **100** comprises a spiral groove **140** formed in one of the inner housing **102** and the outer housing **104**; and

a bolt **110** operably connected to the other of the inner housing **102** and the outer housing **104**, the bolt **110** being disposed in the spiral groove **140**.

17. A rollable display device comprising:

an inner housing **102**, the inner housing **102** having an inner slot **108**;

an outer housing **104**, the outer housing **104** being rotatable about the inner housing **102**;

a rollable display **106**, the rollable display **106** having a bend portion **118**, the bend portion **118** being disposed through the inner slot **108**; and

means for reducing strain of the bend portion **118**.

18. The device of claim 16 wherein the strain reducing means comprises means for increasing radius of the bend portion **31**.

- 14 -

19. The device of claim 16 wherein the strain reducing means comprises means for locating a neutral line of the rollable display **106** at a selected layer of the bend portion **31**.
20. The device of claim 16 wherein the strain reducing means comprises means for reducing cycling of the bend portion **31**.
21. The device of claim 16 further comprising means for switching, the switching means being responsive to position of the rollable display **106**.
22. A rollable display device comprising:
 - an inner housing **102**, the inner housing **102** having an inner slot **108** and an opening **112**;
 - an outer housing **104**, the outer housing **104** being rotatable about the inner housing **102**, the outer housing **104** having an outer slot **114** and a cavity **116**;
 - a rollable display **106**, the rollable display **106** being disposed through the inner slot **108** and the outer slot **114**;
 - a bolt **110**, the bolt **110** being slidably disposed in the opening **112**; and
 - a spring **134**, the spring **134** urging the bolt **110** toward the outer housing **104**;wherein the bolt **110** is received in the cavity **116** when a desired length of the rollable display **106** is positioned between the inner slot **108** and the outer slot **114**.
23. The device of claim 21 further comprising a switch **124**, the switch **124** being responsive to position of the bolt **110**.

1/6

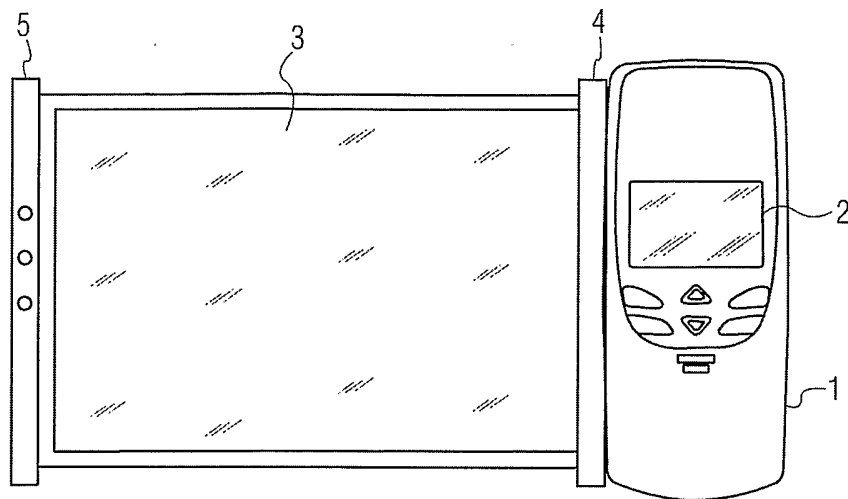

FIG. 1

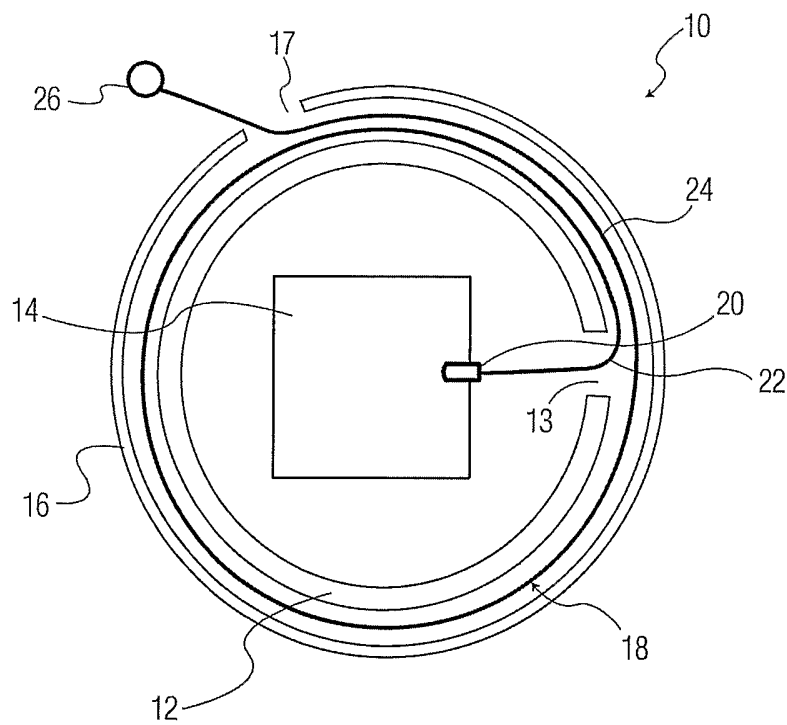

FIG. 2

2/6

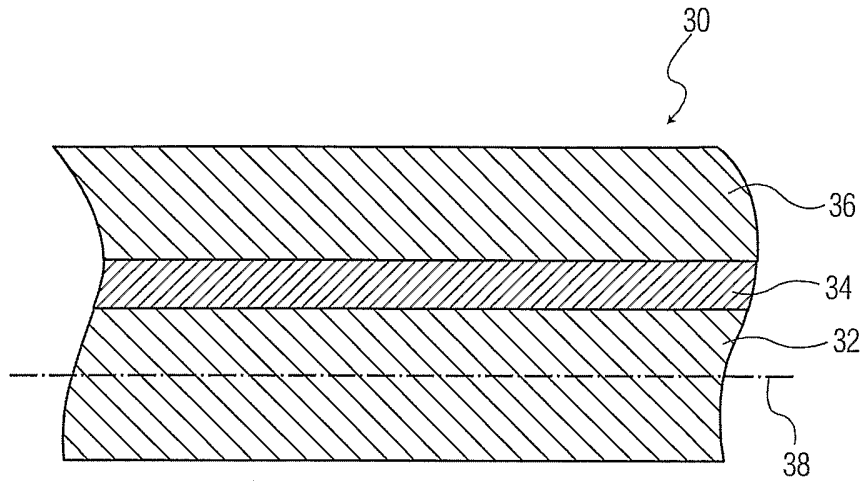

FIG. 3

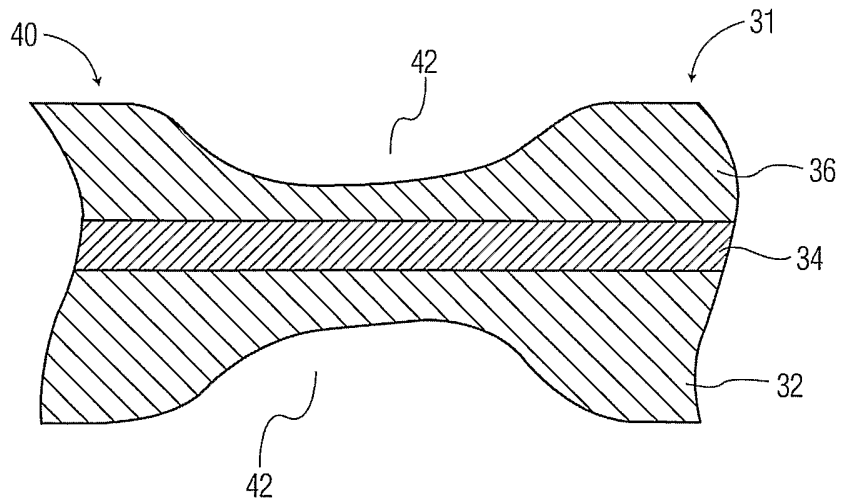

FIG. 4

3/6

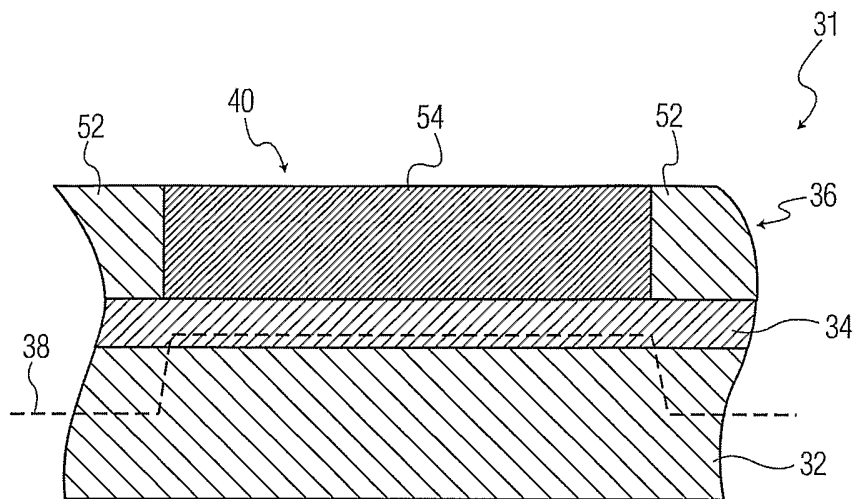

FIG. 5

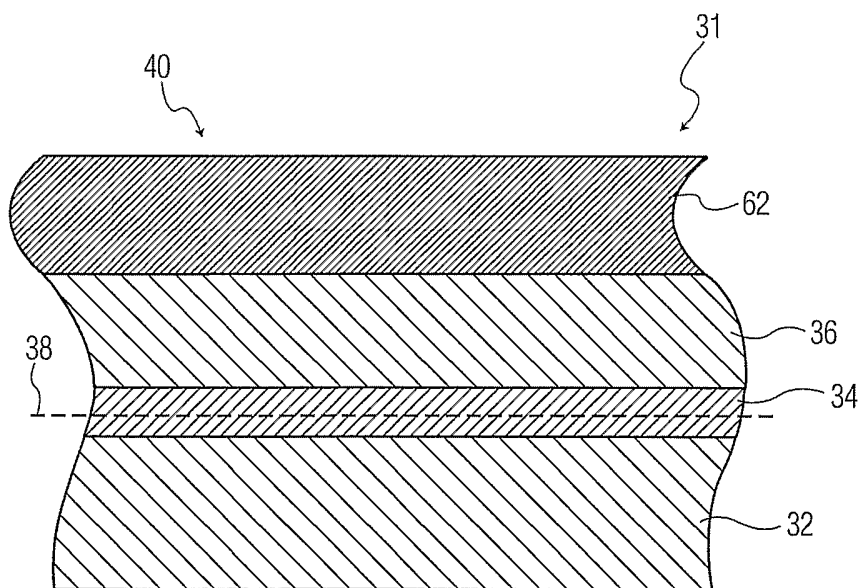

FIG. 6

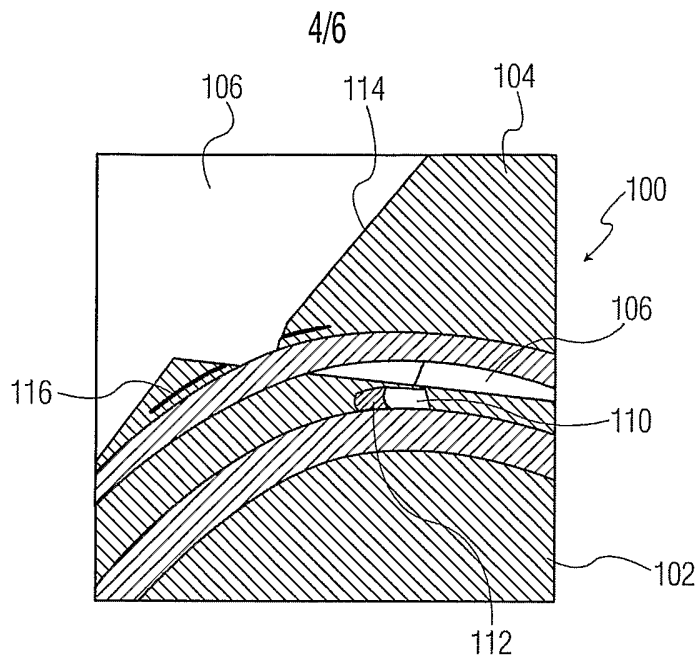

FIG. 7

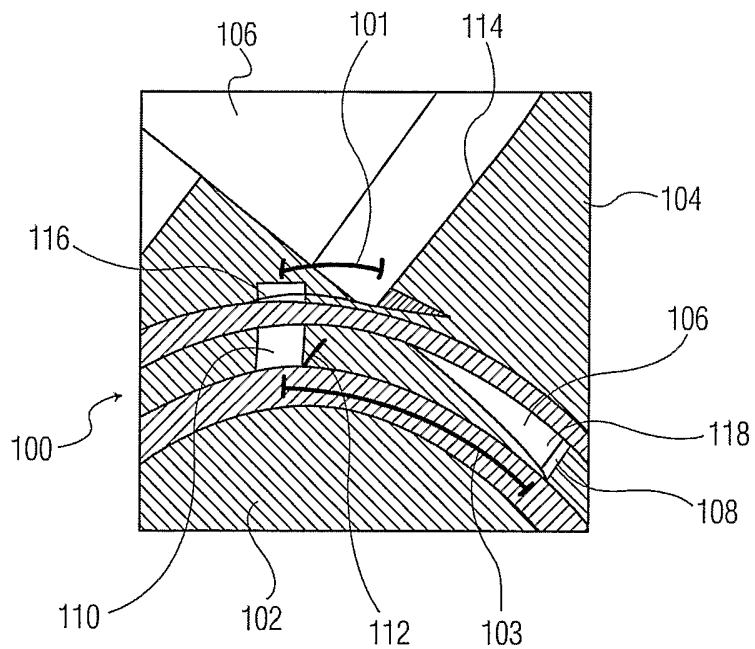

FIG. 8

5/6

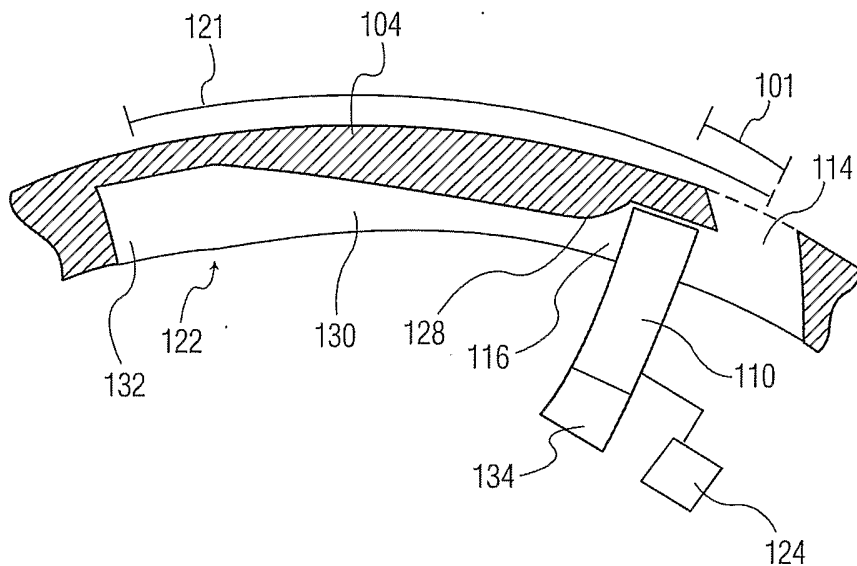

FIG. 9

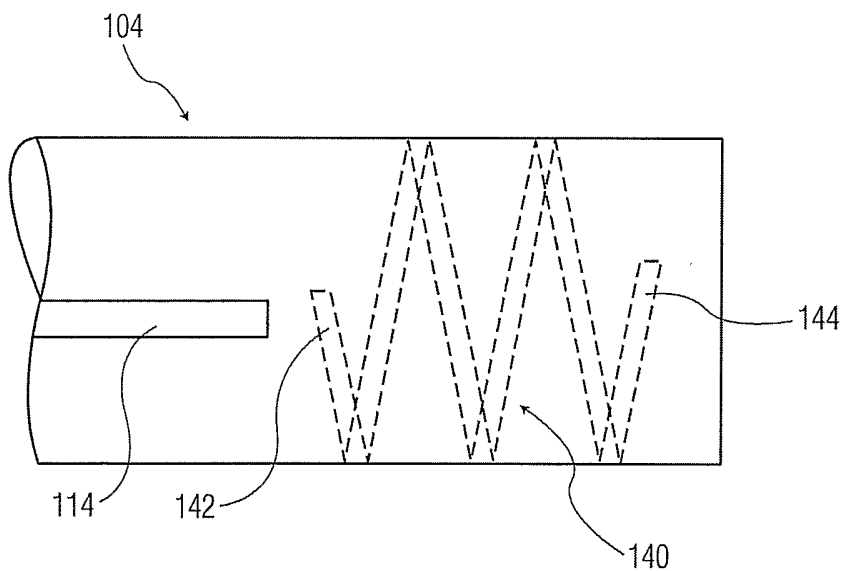

FIG. 10

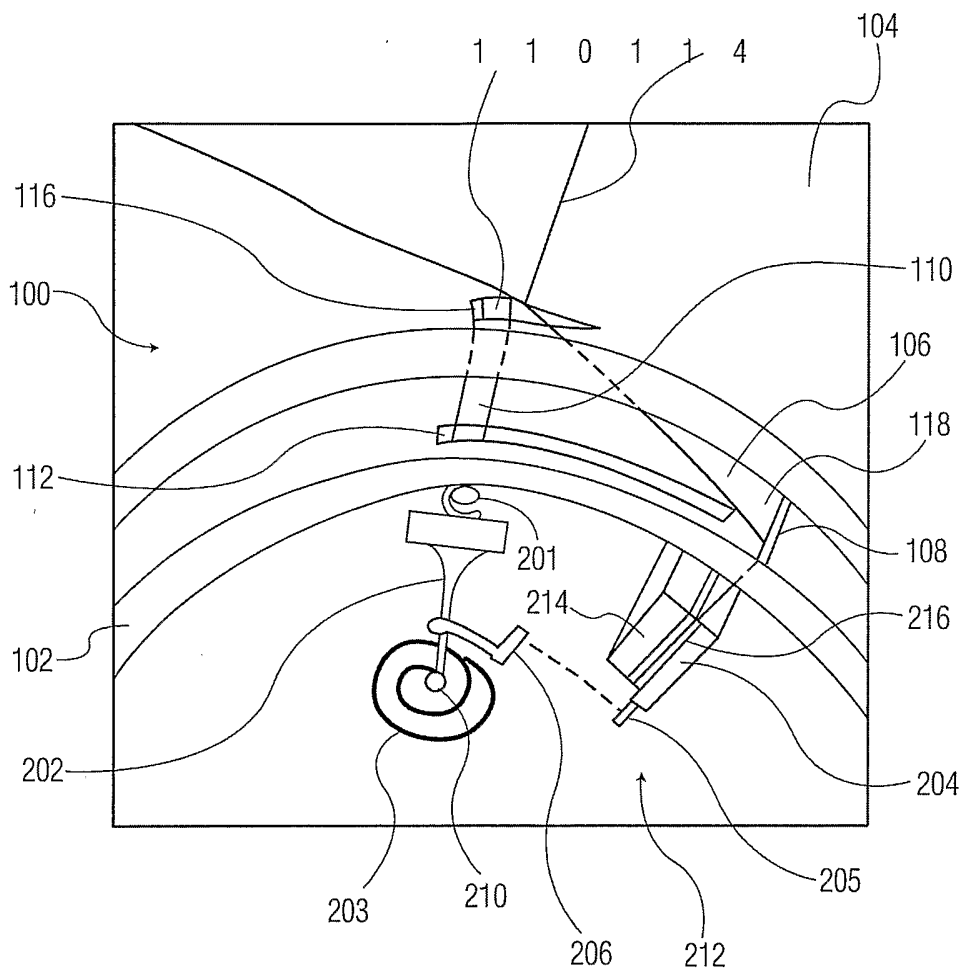

FIG. 11

INTERNATIONAL SEARCH REPORT

 International Application No
 PCT/IB2005/051585

 A. CLASSIFICATION OF SUBJECT MATTER
 IPC 7 G02F1/13

According to International Patent Classification (IPC) or to both national classification and IPC

B. FIELDS SEARCHED

Minimum documentation searched (classification system followed by classification symbols)

IPC 7 G02F G06F G09F

Documentation searched other than minimum documentation to the extent that such documents are included in the fields searched

Electronic data base consulted during the international search (name of data base and, where practical, search terms used)

EPO-Internal, WPI Data, PAJ

C. DOCUMENTS CONSIDERED TO BE RELEVANT

Category *	Citation of document, with indication, where appropriate, of the relevant passages	Relevant to claim No.
A	US 2002/070910 A1 (FUJIEDA ICHIRO ET AL) 13 June 2002 (2002-06-13) paragraphs '0060! - '0062!; figures 3,4	1-23
A	US 2003/077453 A1 (OAKU HITOSHI ET AL) 24 April 2003 (2003-04-24) paragraphs '0013!, '0014!, '0030!, '0031!	1-23
A	LEMME H: "DISPLAYS ZUM AUFROLLEN ELEKTRONISCHES PAPIER UND ELEKTRONISCHE TINTE KOMMEN" ELEKTRONIK, WEKA FACHZEITSCR.-VERLAG, MUNCHEN, DE, vol. 52, no. 16, 5 August 2003 (2003-08-05), pages 56-61, XP001168498 ISSN: 0013-5658 abstract	1-23

 Further documents are listed in the continuation of box C.

 Patent family members are listed in annex.

* Special categories of cited documents:

A document defining the general state of the art which is not considered to be of particular relevance

E earlier document but published on or after the international filing date

L document which may throw doubts on priority claim(s) or which is cited to establish the publication date of another citation or other special reason (as specified)

O document referring to an oral disclosure, use, exhibition or other means

P document published prior to the international filing date but later than the priority date claimed

T later document published after the international filing date or priority date and not in conflict with the application but cited to understand the principle or theory underlying the invention

X document of particular relevance; the claimed invention cannot be considered novel or cannot be considered to involve an inventive step when the document is taken alone

Y document of particular relevance; the claimed invention cannot be considered to involve an inventive step when the document is combined with one or more other such documents, such combination being obvious to a person skilled in the art.

& document member of the same patent family

Date of the actual completion of the international search

31 August 2005

Date of mailing of the international search report

06/09/2005

Name and mailing address of the ISA

 European Patent Office, P.B. 5818 Patentlaan 2
 NL - 2280 HV Rijswijk
 Tel. (+31-70) 340-2040, Tx. 31 651 epo nl,
 Fax: (+31-70) 340-3016

Authorized officer

Amorotti, M

INTERNATIONAL SEARCH REPORT

Information on patent family members

International Application No
PCT/IB2005/051585

Patent document cited in search report	A1	Publication date		Patent family member(s)	Publication date
US 2002070910	A1	13-06-2002	JP	2002182582 A	26-06-2002
			CN	1359077 A ,C	17-07-2002
			TW	594565 B	21-06-2004
<hr style="border-top: 1px dashed black;"/>					
US 2003077453	A1	24-04-2003	JP	2003122269 A	25-04-2003
			CN	1412610 A	23-04-2003
			US	2004080676 A1	29-04-2004
<hr style="border-top: 1px dashed black;"/>					